

# Manual



## Vector Signal Generator

**R&S® SMJ100A**  
1403.4507.02



**Dear Customer,**

throughout this manual, the Vector Signal Generator is R&S® SMJ100A is abbreviated as R&S SMJ.

The firmware of the instrument makes use of several valuable open source software packages. The most important of them are listed below together with their corresponding open source license. The verbatim license texts are provided in the user documentation CD-ROM (included in delivery).

<b>Package</b>	<b>Link</b>	<b>License</b>
OpenSSL	<a href="http://www.openssl.org">http://www.openssl.org</a>	OpenSSL/SSLeay
Net-SNMP	<a href="http://www.net-snmp.org">http://www.net-snmp.org</a>	NetSnmp-5.0.8
Xitami	<a href="http://www.xitami.com">http://www.xitami.com</a>	2.5b6
PHP	<a href="http://www.php.net">http://www.php.net</a>	PHP, Version 3
DOJO-AJAX	<a href="http://www.dojotoolkit.org">http://www.dojotoolkit.org</a>	Academic Free License
ResizableLib	<a href="http://www.geocities.com/ppescher">http://www.geocities.com/ppescher</a>	Artistic License
BOOST Library	<a href="http://www.boost.org">http://www.boost.org</a>	Boost Software, v.1
zlib	<a href="http://www.zlib.net">http://www.zlib.net</a>	zlib, v.1.2.3
Xalan Xerces	<a href="http://xalan.apache.org/">http://xalan.apache.org/</a> <a href="http://xerces.apache.org/">http://xerces.apache.org/</a>	Apache, Ver.2
ACE	<a href="http://www.cs.wustl.edu">http://www.cs.wustl.edu</a>	ACE_TAO
TAO (The ACE ORB)	<a href="http://www.cs.wustl.edu">http://www.cs.wustl.edu</a>	ACE_TAO
PC/SC-Lite	<a href="http://www.linuxnet.com/">http://www.linuxnet.com/</a>	PCSCLite
ONC/RPC	<a href="http://www.plt.rwth-aachen.de">http://www.plt.rwth-aachen.de</a>	SUN

The OpenSSL Project for use in the OpenSSL Toolkit (<http://www.openssl.org/>), includes cryptographic software written by Eric Young (eay@cryptsoft.com) and software written by Tim Hudson (tjh@cryptsoft.com).

Rohde & Schwarz would like to thank the open source community for their valuable contribution to embedded computing.

R&S® is a registered trademark of Rohde & Schwarz GmbH & Co. KG.  
Trade names are trademarks of the owners.

**Tabbed Divider Overview**

CD-ROM including complete operating manual and compiled online help  
(provided in the file inside pocket)

**Data Sheet**

- Safety Instructions
- Customer Information Regarding Product Disposal
- Certificate of Quality
- EC Certificate of Conformity
- Support-Center Address
- List of R&S Representatives

User documentation for the Vector Signal Generator R&S SMJ100A

**Tabbed Divider**

- 1 Chapter 1: Putting into Operation**
- 2 Chapter 2: Getting Started**
- 3 Chapter 3: Manual Operation**
- 4 Chapter 4: Instrument Functions**
- 5 Chapter 5: Remote Control Basics**
- 6 Chapter 6: Remote Control Commands**
- 7 Chapter 7: -**
- 8 Chapter 8: Maintenance and Interfaces**
- 9 Chapter 9: Error Messages**

**Index**

**Alphabetical List of Commands**

**Annex**

**Digital Standards**





# Grouped Safety Messages









**Make sure to read through and observe the following safety instructions!**







All plants and locations of the Rohde & Schwarz group of companies make every effort to keep the safety standard of our products up to date and to offer our customers the highest possible degree of safety. Our products and the auxiliary equipment required for them are designed and tested in accordance with the relevant safety standards. Compliance with these standards is continuously monitored by our quality assurance system. The product described here has been designed and tested in accordance with the EC Certificate of Conformity and has left the manufacturer's plant in a condition fully complying with safety standards. To maintain this condition and to ensure safe operation, observe all instructions and warnings provided in this manual. If you have any questions regarding these safety instructions, the Rohde & Schwarz group of companies will be happy to answer them.

Furthermore, it is your responsibility to use the product in an appropriate manner. This product is designed for use solely in industrial and laboratory environments or, if expressly permitted, also in the field and must not be used in any way that may cause personal injury or property damage. You are responsible if the product is used for an intention other than its designated purpose or in disregard of the manufacturer's instructions. The manufacturer shall assume no responsibility for such use of the product.

The product is used for its designated purpose if it is used in accordance with its product documentation and within its performance limits (see data sheet, documentation, the following safety instructions). Using the product requires technical skills and a basic knowledge of English. It is therefore essential that only skilled and specialized staff or thoroughly trained personnel with the required skills be allowed to use the product. If personal safety gear is required for using Rohde & Schwarz products, this will be indicated at the appropriate place in the product documentation. Keep the basic safety instructions and the product documentation in a safe place and pass them on to the subsequent users.

## Symbols and safety labels

							
Observe product documentation	Weight indication for units >18 kg	Danger of electric shock	Warning! Hot surface	PE terminal	Ground	Ground terminal	Attention! Electrostatic sensitive devices

					
Supply voltage ON/OFF	Standby indication	Direct current (DC)	Alternating current (AC)	Direct/alternating current (DC/AC)	Device fully protected by double/reinforced insulation

Observing the safety instructions will help prevent personal injury or damage of any kind caused by dangerous situations. Therefore, carefully read through and adhere to the following safety instructions before putting the product into operation. It is also absolutely essential to observe the additional safety instructions on personal safety that appear in relevant parts of the product documentation. In these safety instructions, the word "product" refers to all merchandise sold and distributed by the Rohde & Schwarz group of companies, including instruments, systems and all accessories.

## Tags and their meaning

DANGER	DANGER indicates a hazardous situation which, if not avoided, will result in death or serious injury.
WARNING	WARNING indicates a hazardous situation which, if not avoided, could result in death or serious injury.
CAUTION	CAUTION indicates a hazardous situation which, if not avoided, may result in minor or moderate injury.
NOTICE	NOTICE indicates a property damage message.

In the product documentation, the word ATTENTION is used synonymously.

These tags are in accordance with the standard definition for civil applications in the European Economic Area. Definitions that deviate from the standard definition may also exist in other economic areas or military applications. It is therefore essential to make sure that the tags described here are always used only in connection with the related product documentation and the related product. The use of tags in connection with unrelated products or documentation can result in misinterpretation and thus contribute to personal injury or material damage.

## Basic safety instructions

1. The product may be operated only under the operating conditions and in the positions specified by the manufacturer. Its ventilation must not be obstructed during operation. Unless otherwise specified, the following requirements apply to Rohde & Schwarz products:  
prescribed operating position is always with the housing floor facing down, IP protection 2X, pollution severity 2, overvoltage category 2, use only in enclosed spaces, max. operation altitude 2000 m above sea level, max. transport altitude 4500 m above sea level.  
A tolerance of  $\pm 10\%$  shall apply to the nominal voltage and of  $\pm 5\%$  to the nominal frequency.
2. Applicable local or national safety regulations and rules for the prevention of accidents must be observed in all work performed. The product may be opened only by authorized, specially trained personnel. Prior to performing any work on the product or opening the product, the product must be disconnected from the supply network. Any adjustments, replacements of parts, maintenance or repair must be carried out only by technical personnel authorized by Rohde & Schwarz. Only original parts may be used for replacing parts relevant to safety (e.g. power switches, power transformers, fuses). A safety test must always be performed after parts relevant to safety have been replaced (visual inspection, PE conductor test, insulation resistance measurement, leakage current measurement, functional test).
3. As with all industrially manufactured goods, the use of substances that induce an allergic reaction (allergens, e.g. nickel) such as aluminum cannot be generally excluded. If you develop an allergic reaction (such as a skin rash, frequent sneezing, red eyes or respiratory difficulties), consult a physician immediately to determine the cause.
4. If products/components are mechanically and/or thermally processed in a manner that goes beyond their intended use, hazardous substances (heavy-metal dust such as lead, beryllium, nickel) may be released. For this reason, the product may only be disassembled, e.g. for disposal purposes, by specially trained personnel. Improper disassembly may be hazardous to your health. National waste disposal regulations must be observed.

5. If handling the product yields hazardous substances or fuels that must be disposed of in a special way, e.g. coolants or engine oils that must be replenished regularly, the safety instructions of the manufacturer of the hazardous substances or fuels and the applicable regional waste disposal regulations must be observed. Also observe the relevant safety instructions in the product documentation.
6. Depending on the function, certain products such as RF radio equipment can produce an elevated level of electromagnetic radiation. Considering that unborn life requires increased protection, pregnant women should be protected by appropriate measures. Persons with pacemakers may also be endangered by electromagnetic radiation. The employer/operator is required to assess workplaces where there is a special risk of exposure to radiation and, if necessary, take measures to avert the danger.
7. Operating the products requires special training and intense concentration. Make certain that persons who use the products are physically, mentally and emotionally fit enough to handle operating the products; otherwise injuries or material damage may occur. It is the responsibility of the employer to select suitable personnel for operating the products.
8. Prior to switching on the product, it must be ensured that the nominal voltage setting on the product matches the nominal voltage of the AC supply network. If a different voltage is to be set, the power fuse of the product may have to be changed accordingly.
9. In the case of products of safety class I with movable power cord and connector, operation is permitted only on sockets with earthing contact and protective earth connection.
10. Intentionally breaking the protective earth connection either in the feed line or in the product itself is not permitted. Doing so can result in the danger of an electric shock from the product. If extension cords or connector strips are implemented, they must be checked on a regular basis to ensure that they are safe to use.
11. If the product has no power switch for disconnection from the AC supply, the plug of the connecting cable is regarded as the disconnecting device. In such cases, it must be ensured that the power plug is easily reachable and accessible at all times (corresponding to the length of connecting cable, approx. 2 m). Functional or electronic switches are not suitable for providing disconnection from the AC supply. If products without power switches are integrated in racks or systems, a disconnecting device must be provided at the system level.
12. Never use the product if the power cable is damaged. Check the power cable on a regular basis to ensure that it is in proper operating condition. By taking appropriate safety measures and carefully laying the power cable, ensure that the cable cannot be damaged and that no one can be hurt by e.g. tripping over the cable or suffering an electric shock.
13. The product may be operated only from TN/TT supply networks fused with max. 16 A (higher fuse only after consulting with the Rohde & Schwarz group of companies).
14. Do not insert the plug into sockets that are dusty or dirty. Insert the plug firmly and all the way into the socket. Otherwise, this can result in sparks, fire and/or injuries.
15. Do not overload any sockets, extension cords or connector strips; doing so can cause fire or electric shocks.
16. For measurements in circuits with voltages  $V_{\text{rms}} > 30 \text{ V}$ , suitable measures (e.g. appropriate measuring equipment, fusing, current limiting, electrical separation, insulation) should be taken to avoid any hazards.
17. Ensure that the connections with information technology equipment comply with IEC 950/EN 60950.
18. Unless expressly permitted, never remove the cover or any part of the housing while the product is in operation. Doing so will expose circuits and components and can lead to injuries, fire or damage to the product.
19. If a product is to be permanently installed, the connection between the PE terminal on site and the product's PE conductor must be made first before any other connection is made. The product may be installed and connected only by a license electrician.

## Grouped Safety Messages

20. For permanently installed equipment without built-in fuses, circuit breakers or similar protective devices, the supply circuit must be fused in such a way that suitable protection is provided for users and products.
21. Do not insert any objects into the openings in the housing that are not designed for this purpose. Never pour any liquids onto or into the housing. This can cause short circuits inside the product and/or electric shocks, fire or injuries.
22. Use suitable overvoltage protection to ensure that no overvoltage (such as that caused by a thunderstorm) can reach the product. Otherwise the operating personnel will be endangered by electric shocks.
23. Rohde & Schwarz products are not protected against penetration of liquids, unless otherwise specified (see also safety instruction 1.). If this is not taken into account, there exists the danger of electric shock for the user or damage to the product, which can also lead to personal injury.
24. Never use the product under conditions in which condensation has formed or can form in or on the product, e.g. if the product was moved from a cold to a warm environment.
25. Do not close any slots or openings on the product, since they are necessary for ventilation and prevent the product from overheating. Do not place the product on soft surfaces such as sofas or rugs or inside a closed housing, unless this is well ventilated.
26. Do not place the product on heat-generating devices such as radiators or fan heaters. The temperature of the environment must not exceed the maximum temperature specified in the data sheet.
27. Batteries and storage batteries must not be exposed to high temperatures or fire. Keep batteries and storage batteries away from children. Do not short-circuit batteries and storage batteries.  
If batteries or storage batteries are improperly replaced, this can cause an explosion (warning: lithium cells). Replace the battery or storage battery only with the matching Rohde & Schwarz type (see spare parts list). Batteries and storage batteries must be recycled and kept separate from residual waste. Batteries and storage batteries that contain lead, mercury or cadmium are hazardous waste. Observe the national regulations regarding waste disposal and recycling.
28. Please be aware that in the event of a fire, toxic substances (gases, liquids etc.) that may be hazardous to your health may escape from the product.
29. The product can be very heavy. Be careful when moving it to avoid back or other physical injuries.
30. Do not place the product on surfaces, vehicles, cabinets or tables that for reasons of weight or stability are unsuitable for this purpose. Always follow the manufacturer's installation instructions when installing the product and fastening it to objects or structures (e.g. walls and shelves).
31. Handles on the products are designed exclusively for personnel to hold or carry the product. It is therefore not permissible to use handles for fastening the product to or on means of transport such as cranes, fork lifts, wagons, etc. The user is responsible for securely fastening the products to or on the means of transport and for observing the safety regulations of the manufacturer of the means of transport. Noncompliance can result in personal injury or material damage.
32. If you use the product in a vehicle, it is the sole responsibility of the driver to drive the vehicle safely. Adequately secure the product in the vehicle to prevent injuries or other damage in the event of an accident. Never use the product in a moving vehicle if doing so could distract the driver of the vehicle. The driver is always responsible for the safety of the vehicle. The manufacturer assumes no responsibility for accidents or collisions.
33. If a laser product (e.g. a CD/DVD drive) is integrated in a Rohde & Schwarz product, do not use any other settings or functions than those described in the product documentation. Otherwise this may be hazardous to your health, since the laser beam can cause irreversible damage to your eyes. Never try to take such products apart, and never look into the laser beam.
34. Prior to cleaning, disconnect the product from the AC supply. Use a soft, non-linting cloth to clean the product. Never use chemical cleaning agents such as alcohol, acetone or diluent for cellulose lacquers.

# Informaciones elementales de seguridad

**¡Es imprescindible leer y observar las siguientes instrucciones e informaciones de seguridad!**







El principio del grupo de empresas Rohde & Schwarz consiste en tener nuestros productos siempre al día con los estándares de seguridad y de ofrecer a nuestros clientes el máximo grado de seguridad. Nuestros productos y todos los equipos adicionales son siempre fabricados y examinados según las normas de seguridad vigentes. Nuestra sección de gestión de la seguridad de calidad controla constantemente que sean cumplidas estas normas. El presente producto ha sido fabricado y examinado según el comprobante de conformidad adjunto según las normas de la CE y ha salido de nuestra planta en estado impecable según los estándares técnicos de seguridad. Para poder preservar este estado y garantizar un funcionamiento libre de peligros, el usuario deberá atenerse a todas las indicaciones, informaciones de seguridad y notas de alerta. El grupo de empresas Rohde & Schwarz está siempre a su disposición en caso de que tengan preguntas referentes a estas informaciones de seguridad.

Además queda en la responsabilidad del usuario utilizar el producto en la forma debida. Este producto está destinado exclusivamente al uso en la industria y el laboratorio o, si ha sido expresamente autorizado, para aplicaciones de campo y de ninguna manera deberá ser utilizado de modo que alguna persona/cosa pueda sufrir daño. El uso del producto fuera de sus fines definidos o despreciando las informaciones de seguridad del fabricante queda en la responsabilidad del usuario. El fabricante no se hace en ninguna forma responsable de consecuencias a causa del mal uso del producto.

Se parte del uso correcto del producto para los fines definidos si el producto es utilizado dentro de las instrucciones de la correspondiente documentación de producto y dentro del margen de rendimiento definido (ver hoja de datos, documentación, informaciones de seguridad que siguen). El uso del producto hace necesarios conocimientos profundos y conocimientos básicas del idioma inglés. Por eso se debe tener en cuenta que el producto sólo pueda ser operado por personal especializado o personas minuciosamente instruidas con las capacidades correspondientes. Si fuera necesaria indumentaria de seguridad para el uso de productos de R&S, encontrará la información debida en la documentación del producto en el capítulo correspondiente. Guarde bien las informaciones de seguridad elementales, así como la documentación del producto y entréguela a usuarios posteriores.

## Símbolos y definiciones de seguridad

							
Ver documentación de producto	Informaciones para maquinaria con un peso de > 18kg	Peligro de golpe de corriente	¡Advertencia! Superficie caliente	Conexión a conductor protector	Conexión a tierra	Conexión a masa conductora	¡Cuidado! Elementos de construcción con peligro de carga electrostática

					
Potencia EN MARCHA/PARADA	Indicación Stand-by	Corriente continua DC	Corriente alterna AC	Corriente continua/- alterna DC/AC	El aparato está protegido en su totalidad por un aislamiento de doble refuerzo

Tener en cuenta las informaciones de seguridad sirve para tratar de evitar daños y peligros de toda clase. Es necesario de que se lean las siguientes informaciones de seguridad concienzudamente y se tengan en cuenta debidamente antes de la puesta en funcionamiento del producto. También deberán ser tenidas en cuenta las informaciones para la protección de personas que encontrarán en el capítulo correspondiente de la documentación de producto y que también son obligatorias de seguir. En las informaciones de seguridad actuales hemos juntado todos los objetos vendidos por el grupo de empresas Rohde & Schwarz bajo la denominación de „producto“, entre ellos también aparatos, instalaciones así como toda clase de accesorios.

### Palabras de señal y su significado

PELIGRO	Identifica un peligro directo con riesgo elevado de provocar muerte o lesiones de gravedad si no se toman las medidas oportunas.
ADVERTENCIA	Identifica un posible peligro con riesgo medio de provocar muerte o lesiones (de gravedad) si no se toman las medidas oportunas.
ATENCIÓN	Identifica un peligro con riesgo reducido de provocar lesiones de gravedad media o leve si no se toman las medidas oportunas.
AVISO	Indica la posibilidad de utilizar mal el producto y a consecuencia dañarlo.

En la documentación del producto se emplea de forma sinónima el término CUIDADO.

Las palabras de señal corresponden a la definición habitual para aplicaciones civiles en el área económica europea. Pueden existir definiciones diferentes a esta definición en otras áreas económicas o en aplicaciones militares. Por eso se deberá tener en cuenta que las palabras de señal aquí descritas sean utilizadas siempre solamente en combinación con la correspondiente documentación de producto y solamente en combinación con el producto correspondiente. La utilización de las palabras de señal en combinación con productos o documentaciones que no les correspondan puede llevar a malinterpretaciones y tener por consecuencia daños en personas u objetos.

### Informaciones de seguridad elementales

1. El producto solamente debe ser utilizado según lo indicado por el fabricante referente a la situación y posición de funcionamiento sin que se obstruya la ventilación. Si no se convino de otra manera, es para los productos R&S válido lo que sigue:  
como posición de funcionamiento se define por principio la posición con el suelo de la caja para abajo, modo de protección IP 2X, grado de suciedad 2, categoría de sobrecarga eléctrica 2, utilizar solamente en estancias interiores, utilización hasta 2000 m sobre el nivel del mar, transporte hasta 4.500 m sobre el nivel del mar.  
Se aplicará una tolerancia de  $\pm 10\%$  sobre el voltaje nominal y de  $\pm 5\%$  sobre la frecuencia nominal.
2. En todos los trabajos deberán ser tenidas en cuenta las normas locales de seguridad de trabajo y de prevención de accidentes. El producto solamente debe de ser abierto por personal especializado autorizado. Antes de efectuar trabajos en el producto o abrirlo deberá este ser desconectado de la corriente. El ajuste, el cambio de partes, la manutención y la reparación deberán ser solamente efectuadas por electricistas autorizados por R&S. Si se reponen partes con importancia para los aspectos de seguridad (por ejemplo el enchufe, los transformadores o los fusibles), solamente podrán ser sustituidos por partes originales. Después de cada recambio de partes elementales para la seguridad deberá ser efectuado un control de seguridad (control a primera vista, control de conductor protector, medición de resistencia de aislamiento, medición de la corriente conductora, control de funcionamiento).

3. Como en todo producto de fabricación industrial no puede ser excluido en general de que se produzcan al usarlo elementos que puedan generar alergias, los llamados elementos alergénicos (por ejemplo el níquel). Si se produjeran en el trato con productos R&S reacciones alérgicas, como por ejemplo urticaria, estornudos frecuentes, irritación de la conjuntiva o dificultades al respirar, se deberá consultar inmediatamente a un médico para averiguar los motivos de estas reacciones.
  4. Si productos / elementos de construcción son tratados fuera del funcionamiento definido de forma mecánica o térmica, pueden generarse elementos peligrosos (polvos de sustancia de metales pesados como por ejemplo plomo, berilio, níquel). La partición elemental del producto, como por ejemplo sucede en el tratamiento de materias residuales, debe de ser efectuada solamente por personal especializado para estos tratamientos. La partición elemental efectuada inadecuadamente puede generar daños para la salud. Se deben tener en cuenta las directivas nacionales referentes al tratamiento de materias residuales.
  5. En el caso de que se produjeran agentes de peligro o combustibles en la aplicación del producto que debieran de ser transferidos a un tratamiento de materias residuales, como por ejemplo agentes refrigerantes que deben ser repuestos en periodos definidos, o aceites para motores, deberán ser tenidas en cuenta las prescripciones de seguridad del fabricante de estos agentes de peligro o combustibles y las regulaciones regionales para el tratamiento de materias residuales. Cuiden también de tener en cuenta en caso dado las prescripciones de seguridad especiales en la descripción del producto.
  6. Ciertos productos, como por ejemplo las instalaciones de radiocomunicación RF, pueden a causa de su función natural, emitir una radiación electromagnética aumentada. En vista a la protección de la vida en desarrollo deberían ser protegidas personas embarazadas debidamente. También las personas con un bypass pueden correr peligro a causa de la radiación electromagnética.
- El empresario/usuario está comprometido a valorar y señalar áreas de trabajo en las que se corra un riesgo aumentado de exposición a radiaciones para evitar riesgos.
7. La utilización de los productos requiere instrucciones especiales y una alta concentración en el manejo. Debe de ponerse por seguro de que las personas que manejen los productos estén a la altura de los requerimientos necesarios referente a sus aptitudes físicas, psíquicas y emocionales, ya que de otra manera no se pueden excluir lesiones o daños de objetos. El empresario lleva la responsabilidad de seleccionar el personal usuario apto para el manejo de los productos.
  8. Antes de la puesta en marcha del producto se deberá tener por seguro de que la tensión preseleccionada en el producto equivalga a la del la red de distribución. Si es necesario cambiar la preselección de la tensión también se deberán en caso dabo cambiar los fusibles correspondientes del producto.
  9. Productos de la clase de seguridad I con alimentación móvil y enchufe individual de producto solamente deberán ser conectados para el funcionamiento a tomas de corriente de contacto de seguridad y con conductor protector conectado.
  10. Queda prohibida toda clase de interrupción intencionada del conductor protector, tanto en la toma de corriente como en el mismo producto. Puede tener como consecuencia el peligro de golpe de corriente por el producto. Si se utilizaran cables o enchufes de extensión se deberá poner al seguro que es controlado su estado técnico de seguridad.
  11. Si el producto no está equipado con un interruptor para desconectarlo de la red, se deberá considerar el enchufe del cable de distribución como interruptor. En estos casos deberá asegurar de que el enchufe sea de fácil acceso y nabejo (según la medida del cable de distribución, aproximadamente 2 m). Los interruptores de función o electrónicos no son aptos para el corte de la red eléctrica. Si los productos sin interruptor están integrados en bastidores o instalaciones, se deberá instalar el interruptor al nivel de la instalación.

12. No utilice nunca el producto si está dañado el cable eléctrico. Compruebe regularmente el correcto estado de los cables de conexión a red. Asegure a través de las medidas de protección y de instalación adecuadas de que el cable de eléctrico no pueda ser dañado o de que nadie pueda ser dañado por él, por ejemplo al tropezar o por un golpe de corriente.
13. Solamente está permitido el funcionamiento en redes de distribución TN/TT aseguradas con fusibles de como máximo 16 A (utilización de fusibles de mayor amperaje sólo previa consulta con el grupo de empresas Rohde & Schwarz).
14. Nunca conecte el enchufe en tomas de corriente sucias o llenas de polvo. Introduzca el enchufe por completo y fuertemente en la toma de corriente. Si no tiene en consideración estas indicaciones se arriesga a que se originen chispas, fuego y/o heridas.
15. No sobrecargue las tomas de corriente, los cables de extensión o los enchufes de extensión ya que esto pudiera causar fuego o golpes de corriente.
16. En las mediciones en circuitos de corriente con una tensión de entrada de  $U_{eff} > 30$  V se deberá tomar las precauciones debidas para impedir cualquier peligro (por ejemplo medios de medición adecuados, seguros, limitación de tensión, corte protector, aislamiento etc.).
17. En caso de conexión con aparatos de la técnica informática se deberá tener en cuenta que estos cumplan los requisitos del estándar IEC950/EN60950.
18. A menos que esté permitido expresamente, no retire nunca la tapa ni componentes de la carcasa mientras el producto esté en servicio. Esto pone a descubierto los cables y componentes eléctricos y puede causar heridas, fuego o daños en el producto.
19. Si un producto es instalado fijamente en un lugar, se deberá primero conectar el conductor protector fijo con el conductor protector del aparato antes de hacer cualquier otra conexión. La instalación y la conexión deberán ser efectuadas por un electricista especializado.
20. En caso de que los productos que son instalados fijamente en un lugar sean sin protector implementado, autointerruptor o similares objetos de protección, el circuito de suministro de corriente deberá estar protegido de manera que usuarios y productos estén suficientemente protegidos.
21. Por favor, no introduzca ningún objeto que no esté destinado a ello en los orificios de la caja del aparato. No vierta nunca ninguna clase de líquidos sobre o en la caja. Esto puede producir cortocircuitos en el producto y/o puede causar golpes de corriente, fuego o heridas.
22. Asegúrese con la protección adecuada de que no pueda originarse en el producto una sobrecarga por ejemplo a causa de una tormenta. Si no se verá el personal que lo utilice expuesto al peligro de un golpe de corriente.
23. Los productos R&S no están protegidos contra líquidos si no es que exista otra indicación, ver también punto 1. Si no se tiene en cuenta esto se arriesga el peligro de golpe de corriente para el usuario o de daños en el producto lo cual también puede llevar al peligro de personas.
24. No utilice el producto bajo condiciones en las que pueda producirse y se hayan producido líquidos de condensación en o dentro del producto como por ejemplo cuando se desplaza el producto de un lugar frío a un lugar caliente.
25. Por favor no cierre ninguna ranura u orificio del producto, ya que estas son necesarias para la ventilación e impiden que el producto se caliente demasiado. No pongan el producto encima de materiales blandos como por ejemplo sofás o alfombras o dentro de una caja cerrada, si esta no está suficientemente ventilada.
26. No ponga el producto sobre aparatos que produzcan calor, como por ejemplo radiadores o calentadores. La temperatura ambiental no debe superar la temperatura máxima especificada en la hoja de datos.



27. Baterías y acumuladores no deben de ser expuestos a temperaturas altas o al fuego. Guardar baterías y acumuladores fuera del alcance de los niños. No cortocircuitar baterías ni acumuladores. Si las baterías o los acumuladores no son cambiados con la debida atención existirá peligro de explosión (atención células de litio). Cambiar las baterías o los acumuladores solamente por los del tipo R&S correspondiente (ver lista de piezas de recambio). Las baterías y acumuladores deben reutilizarse y no deben acceder a los vertederos. Las baterías y acumuladores que contienen plomo, mercurio o cadmio deben tratarse como residuos especiales. Respete en esta relación las normas nacionales de evacuación y reciclaje.
28. Por favor tengan en cuenta que en caso de un incendio pueden desprenderse del producto agentes venenosos (gases, líquidos etc.) que pueden generar daños a la salud.
29. El producto puede poseer un peso elevado. Muévelo con cuidado para evitar lesiones en la espalda u otras partes corporales.
30. No sitúe el producto encima de superficies, vehículos, estantes o mesas, que por sus características de peso o de estabilidad no sean aptas para él. Siga siempre las instrucciones de instalación del fabricante cuando instale y asegure el producto en objetos o estructuras (por ejemplo paredes y estantes).
31. Las asas instaladas en los productos sirven solamente de ayuda para el manejo que solamente está previsto para personas. Por eso no está permitido utilizar las asas para la sujeción en o sobre medios de transporte como por ejemplo grúas, carretillas elevadoras de horquilla, carros etc. El usuario es responsable de que los productos sean sujetados de forma segura a los medios de transporte y de que las prescripciones de seguridad del fabricante de los medios de transporte sean observadas. En caso de que no se tengan en cuenta pueden causarse daños en personas y objetos.
32. Si llega a utilizar el producto dentro de un vehículo, queda en la responsabilidad absoluta del conductor que conducir el vehículo de manera segura. Asegure el producto dentro del vehículo debidamente para evitar en caso de un accidente las lesiones u otra clase de daños. No utilice nunca el producto dentro de un vehículo en movimiento si esto pudiera distraer al conductor. Siempre queda en la responsabilidad absoluta del conductor la seguridad del vehículo. El fabricante no asumirá ninguna clase de responsabilidad por accidentes o colisiones.
33. Dado el caso de que esté integrado un producto de láser en un producto R&S (por ejemplo CD/DVD-ROM) no utilice otras instalaciones o funciones que las descritas en la documentación de producto. De otra manera pondrá en peligro su salud, ya que el rayo láser puede dañar irreversiblemente sus ojos. Nunca trate de descomponer estos productos. Nunca mire dentro del rayo láser.
34. Antes de proceder a la limpieza, desconecte el producto de la red. Realice la limpieza con un paño suave, que no se deshilache. No utilice de ninguna manera agentes limpiadores químicos como, por ejemplo, alcohol, acetona o nitrodiluyente.



# Customer Information Regarding Product Disposal

The German Electrical and Electronic Equipment (ElektroG) Act is an implementation of the following EC directives:

- 2002/96/EC on waste electrical and electronic equipment (WEEE) and
- 2002/95/EC on the restriction of the use of certain hazardous substances in electrical and electronic equipment (RoHS).

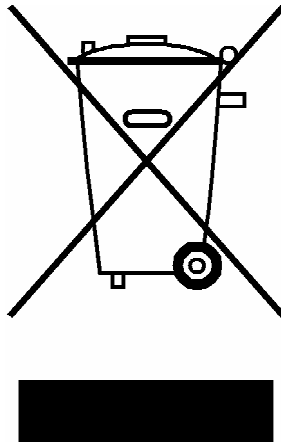

Product labeling in accordance with EN 50419

Once the lifetime of a product has ended, this product must not be disposed of in the standard domestic refuse. Even disposal via the municipal collection points for waste electrical and electronic equipment is not permitted.

Rohde & Schwarz GmbH & Co. KG has developed a disposal concept for the environmental-friendly disposal or recycling of waste material and fully assumes its obligation as a producer to take back and dispose of electrical and electronic waste in accordance with the ElektroG Act.

Please contact your local service representative to dispose of the product.





## Certified Quality System

**DIN EN ISO 9001 : 2000**  
**DIN EN 9100 : 2003**  
**DIN EN ISO 14001 : 2004**

DQS REG. NO 001954 QM UM

### QUALITÄTSZERTIFIKAT

*Sehr geehrter Kunde,*  
Sie haben sich für den Kauf eines Rohde & Schwarz-Produktes entschieden. Hiermit erhalten Sie ein nach modernsten Fertigungsmethoden hergestelltes Produkt. Es wurde nach den Regeln unseres Managementsystems entwickelt, gefertigt und geprüft. Das Rohde & Schwarz Managementsystem ist zertifiziert nach:

DIN EN ISO 9001:2000  
DIN EN 9100:2003  
DIN EN ISO 14001:2004

### CERTIFICATE OF QUALITY

*Dear Customer,*  
you have decided to buy a Rohde & Schwarz product. You are thus assured of receiving a product that is manufactured using the most modern methods available. This product was developed, manufactured and tested in compliance with our quality management system standards. The Rohde & Schwarz quality management system is certified according to:

DIN EN ISO 9001:2000  
DIN EN 9100:2003  
DIN EN ISO 14001:2004

### CERTIFICAT DE QUALITÉ

*Cher Client,*  
vous avez choisi d'acheter un produit Rohde & Schwarz. Vous disposez donc d'un produit fabriqué d'après les méthodes les plus avancées. Le développement, la fabrication et les tests respectent nos normes de gestion qualité. Le système de gestion qualité de Rohde & Schwarz a été homologué conformément aux normes:

DIN EN ISO 9001:2000  
DIN EN 9100:2003  
DIN EN ISO 14001:2004







Certificate No.: 2005-09

This is to certify that:

Equipment type	Stock No.	Designation
SMJ100A	1403.4507.02	Vektorsignalgenerator
SMJ-B9	1404.1501.02	Baseband Generator
SMJ-B10	1403.8902.02	Baseband Generator
SMJ-B11	1403.9009.02	Baseband Generator
SMJ-B13	1403.9109.02	Baseband Main Modul
SMJ-B16	1403.9409.02	Differential I/Q Output
SMJ-B20	1403.9209.02	FM/PHIM Modulator
SMJ-B50	1410.5505.02	Baseband Generator
SMJ-B51	1410.5605.02	Baseband Generator
SMJ-B81	1403.9309.02	Rear Connectors
SMJ-B103	1403.8502.02	Frequency Range 100 kHz – 3 GHz
SMJ-B106	1403.8702.02	Frequency Range 100 kHz – 6 GHz

complies with the provisions of the Directive of the Council of the European Union on the approximation of the laws of the Member States

- relating to electrical equipment for use within defined voltage limits (2006/95/EG)
- relating to electromagnetic compatibility (2004/108/EG)

Conformity is proven by compliance with the following standards:

EN61010-1 : 2001-12  
EN55011 : 1998 + A1 : 1999 + A2 : 2002, Class B  
EN61326 : 1997 + A1 : 1998 + A2 : 2001 + A3 : 2003

For the assessment of electromagnetic compatibility, the limits of radio interference for Class B equipment as well as the immunity to interference for operation in industry have been used as a basis.

Affixing the EC conformity mark as from 2005

**ROHDE & SCHWARZ GmbH & Co. KG**  
Mühldorfstr. 15, D-81671 München

Munich, 2007-11-16

Central Quality Management MF-QZ / Radde



Certificate No.: 2007-64

This is to certify that:

Equipment type	Stock No.	Designation
SMJ-B18	1410.5705.02	Digital Baseband Output

complies with the provisions of the Directive of the Council of the European Union on the approximation of the laws of the Member States

- relating to electromagnetic compatibility (2004/108/EC)

Conformity is proven by compliance with the following standards:

EN 55011 : 1998 + A1 : 1999 + A2 : 2002, Class A  
EN 61326 : 1997 + A1 : 1998 + A2 : 2001 + A3 : 2003

For the assessment of electromagnetic compatibility, the limits of radio interference for Class A equipment as well as the immunity to interference for operation in industry have been used as a basis.

Affixing the EC conformity mark as from 2007

**ROHDE & SCHWARZ GmbH & Co. KG**  
**Mühlldorfstr. 15, D-81671 München**

Munich, 2007-11-16

Central Quality Management MF-QZ / Radde



# Customer Support

## Technical support – where and when you need it

For quick, expert help with any Rohde & Schwarz equipment, contact one of our Customer Support Centers. A team of highly qualified engineers provides telephone support and will work with you to find a solution to your query on any aspect of the operation, programming or applications of Rohde & Schwarz equipment.

## Up-to-date information and upgrades

To keep your instrument up-to-date and to be informed about new application notes related to your instrument, please send an e-mail to the Customer Support Center stating your instrument and your wish. We will take care that you will get the right information.

### USA & Canada

Monday to Friday (except US public holidays)  
8:00 AM – 8:00 PM Eastern Standard Time (EST)

Tel. from USA 888-test-rsa (888-837-8772) (opt 2)  
From outside USA +1 410 910 7800 (opt 2)  
Fax +1 410 910 7801

E-mail [CustomerSupport@rohde-schwarz.com](mailto:CustomerSupport@rohde-schwarz.com)

### East Asia

Monday to Friday (except Singaporean public holidays)  
8:30 AM – 6:00 PM Singapore Time (SGT)

Tel. +65 6 513 0488  
Fax +65 6 846 1090

E-mail [CustomerSupport@rohde-schwarz.com](mailto:CustomerSupport@rohde-schwarz.com)

### Rest of the World

Monday to Friday (except German public holidays)  
08:00 – 17:00 Central European Time (CET)

Tel. from Europe +49 (0) 180 512 42 42\*  
From outside Europe +49 89 4129 13776  
Fax +49 (0) 89 41 29 637 78

E-mail [CustomerSupport@rohde-schwarz.com](mailto:CustomerSupport@rohde-schwarz.com)

\* 0.14 €/Min within the German fixed-line telephone network, varying prices for the mobile telephone network and in different countries.





## Address List

### Headquarters, Plants and Subsidiaries

#### Headquarters

ROHDE & SCHWARZ GmbH & Co. KG  
Mühlendorfstraße 15 · D-81671 München  
P.O.Box 80 14 69 · D-81614 München

Phone +49 (89) 41 29-0  
Fax +49 (89) 41 29-121 64  
[info.rs@rohde-schwarz.com](mailto:info.rs@rohde-schwarz.com)

#### Plants

ROHDE & SCHWARZ Messgerätebau GmbH  
Riedbachstraße 58 · D-87700 Memmingen  
P.O.Box 16 52 · D-87686 Memmingen

Phone +49 (83 31) 1 08-0  
+49 (83 31) 1 08-1124  
[info.rsmb@rohde-schwarz.com](mailto:info.rsmb@rohde-schwarz.com)

ROHDE & SCHWARZ GmbH & Co. KG  
Werk Teisnach  
Kaikenrieder Straße 27 · D-94244 Teisnach  
P.O.Box 11 49 · D-94240 Teisnach

Phone +49 (99 23) 8 50-0  
Fax +49 (99 23) 8 50-174  
[info.rsdt@rohde-schwarz.com](mailto:info.rsdt@rohde-schwarz.com)

ROHDE & SCHWARZ závod  
Vimperk, s.r.o.  
Location Spidrova 49  
CZ-38501 Vimperk

Phone +420 (388) 45 21 09  
Fax +420 (388) 45 21 13

ROHDE & SCHWARZ GmbH & Co. KG  
Dienstleistungszentrum Köln  
Graf-Zeppelin-Straße 18 · D-51147 Köln  
P.O.Box 98 02 60 · D-51130 Köln

Phone +49 (22 03) 49-0  
Fax +49 (22 03) 49 51-229  
[info.rsdc@rohde-schwarz.com](mailto:info.rsdc@rohde-schwarz.com)  
[service.rsdc@rohde-schwarz.com](mailto:service.rsdc@rohde-schwarz.com)

#### Subsidiaries

R&S BICK Mobilfunk GmbH  
Fritz-Hahne-Str. 7 · D-31848 Bad Münder  
P.O.Box 20 02 · D-31844 Bad Münder

Phone +49 (50 42) 9 98-0  
Fax +49 (50 42) 9 98-105  
[info.bick@rohde-schwarz.com](mailto:info.bick@rohde-schwarz.com)

ROHDE & SCHWARZ FTK GmbH  
Wendenschloßstraße 168, Haus 28  
D-12557 Berlin

Phone +49 (30) 658 91-122  
Fax +49 (30) 655 50-221  
[info.ftk@rohde-schwarz.com](mailto:info.ftk@rohde-schwarz.com)

ROHDE & SCHWARZ SIT GmbH  
Am Studio 3  
D-12489 Berlin

Phone +49 (30) 658 84-0  
Fax +49 (30) 658 84-183  
[info.sit@rohde-schwarz.com](mailto:info.sit@rohde-schwarz.com)

R&S Systems GmbH  
Graf-Zeppelin-Straße 18  
D-51147 Köln

Phone +49 (22 03) 49-5 23 25  
Fax +49 (22 03) 49-5 23 36  
[info.rssys@rohde-schwarz.com](mailto:info.rssys@rohde-schwarz.com)

GEDIS GmbH  
Sophienblatt 100  
D-24114 Kiel

Phone +49 (431) 600 51-0  
Fax +49 (431) 600 51-11  
[sales@gedis-online.de](mailto:sales@gedis-online.de)

HAMEG Instruments GmbH  
Industriestraße 6  
D-63533 Mainhausen

Phone +49 (61 82) 800-0  
Fax +49 (61 82) 800-100  
[info@hameg.de](mailto:info@hameg.de)

### Locations Worldwide

Please refer to our homepage: [www.rohde-schwarz.com](http://www.rohde-schwarz.com)

- ◆ Sales Locations
- ◆ Service Locations
- ◆ National Websites



# Contents of User Documentation for the Vector Signal Generator R&S SMJ100A

The user documentation describes the I/Q Modulation Generator R&S SMJ100A and all options. It includes a printed Quick Start Guide and a CD-ROM with the complete operating and service manual in printable pdf-format.

The R&S SMJ is equipped with a context-sensitive online help that offers a help page for each instrument function.

## Quick Start Guide



The present quick start guide describes everything that is needed to put the instrument into operation and to get familiar with the generator. The quick start guide gives an introduction to remote control and manual control via external monitor, mouse and keyboard.

The quick start guide is subdivided into the data sheet plus 3 chapters plus index:

- The data sheet** informs about specifications and characteristics of the instrument.
- Chapter 1** Describes the control elements and connectors on the front and rear panel as well as all procedures required for putting the instrument into operation.
- Chapter 2** Gives an introduction the operating concept and typical applications of the R&S SMJ.
- Chapter 3** Describes key operating modes, the structure of the graphical interface and the principles of manual control.
- Index** Contains an index of the quick start guide.

## Help System

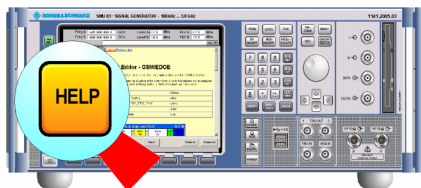

The help system is embedded in the instrument, offering quick, context-sensitive reference to the information needed for operation and programming. The help contains the complete user documentation for the Signal Generator including the contents of the present quick start guide.

The help files (\*.chm) are also available on the CD-ROM and can be used as a standalone help.

## Documentation CD-ROM

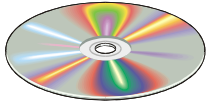

The CD-ROM provides the complete user documentation for the Signal Generator:

- The online help system (\*.chm).
- The complete operating manual and service manual in printable form (\*.pdf).
- The data sheet (brochure and specifications) in printable form.
- Links to different useful sites in the R&S internet.

---

**Note:** Please use the ADOBE® Acrobat® Reader for PDF files and the browser Internet Explorer® ≥ 4.0 for the HTML help.

---

## Optional Documentation

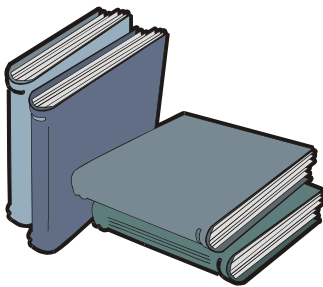

The printed version of the operating and service manual provides the contents of the quick start manual plus the complete reference and the service information for the Signal Generator. This manual can be ordered as an option (stock no. 1403.7458.32 (English - A4 format) or 1403.7458.39 (English - letter format )); see ordering information in the data sheet.

---

**Note:** The CD-ROM contains the \*.pdf version of the manuals.

---

## Operating Manual

The operating manual contains comprehensive information about the instrument functions and remote control, in addition to the chapters of the quick start guide. It includes information about maintenance of the instrument and about error detection listing the error messages which may be output by the instrument. It is subdivided into 10 chapters:

- |                       |                                                                                                                                                         |
|-----------------------|---------------------------------------------------------------------------------------------------------------------------------------------------------|
| <b>The data sheet</b> | informs about specifications and characteristics of the instrument.                                                                                     |
| <b>Chapter 1</b>      | Describes the control elements and connectors on the front and rear panel as well as all procedures required for putting the instrument into operation. |
| <b>Chapter 2</b>      | Gives an introduction to the operating concept and typical applications of the R&S SMJ.                                                                 |
| <b>Chapter 3</b>      | Describes key operating modes, the structure of the graphical interface and the principles of manual control.                                           |

<b>Chapter 4</b>	Forms a reference for manual control of the R&S SMJ and contains a detailed description of all instrument functions and their application. The chapter also lists the remote control command corresponding to each instrument function.
<b>Chapter 5</b>	Describes the basics for programming the R&S SMJ, command processing and the status reporting system.
<b>Chapter 6</b>	Lists all the remote-control commands defined for the instrument.
<b>Chapter 7</b>	-
<b>Chapter 8</b>	Describes preventive maintenance and the characteristics of the instrument's interfaces.
<b>Chapter 9</b>	Gives the status messages and a list of error messages that the R&S SMJ may generate.
<b>Index</b>	Contains an index of the operating manual.
<b>Annex</b>	Lists the remote-control commands in alphabetical order. Contains the description of the Digital Standards supported by the R&S SMJ.

## Service Manual Instrument

The service manual - instrument informs on how to check compliance with rated specifications, on instrument function, repair, troubleshooting and fault elimination. It contains all information required for the maintenance of R&S SMJ by exchanging modules. In addition it describes how to perform a firmware update and how to install options.

## Internet Site

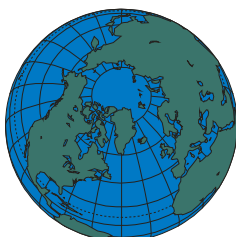

The Rohde & Schwarz internet site: <http://www2.rohde-schwarz.com/product/smj100A.html> provides the most up to date information on the R&S SMJ. Additionally firmware updates including the associated release notes, instrument drivers current data sheets and application notes are provided for download on the internet site.

The current operating manual at a time is available as printable PDF file in the download area.





## Contents - Chapter 1 "Putting into Operation"

<b>Putting into Operation.....</b>	<b>1.2</b>
Introduction - Putting into Operation.....	1.2
Legend for Front Panel View .....	1.2
Display .....	1.2
Keypad for data entry .....	1.4
Keys for setting parameters .....	1.7
Keys for settings and navigation in the display .....	1.8
Analog Inputs and outputs.....	1.9
RF output.....	1.10
Trigger inputs and outputs.....	1.10
Female USB connectors type A .....	1.10
Connector for sensor .....	1.11
Keys for setting the display .....	1.11
Switch .....	1.12
Keys for general instrument settings .....	1.12
Legend for Rear Panel View.....	1.14
LF output .....	1.14
Marker output .....	1.14
AC supply .....	1.14
I/Q signal output .....	1.15
Differential I/Q signal output .....	1.15
I/Q/DATA/CLOCK.....	1.15
Reference signal output.....	1.15
Reference signal input.....	1.16
Input for external analog modulation signal.....	1.16
IEC/IEEE-bus connector.....	1.16
USB connectors type A .....	1.16
USB interface type B .....	1.16
Monitor.....	1.17
AUX I/O interface.....	1.17
BERT .....	1.17
LAN interface.....	1.18
RF .....	1.18
Clock signal output .....	1.18
Instrument triggering.....	1.18

- USER connector ..... 1.19
- Trigger input ..... 1.19
- Putting into Operation ..... 1.20
  - Unpacking the Instrument ..... 1.20
  - Setting up the Instrument or Installing it in a 19" Rack ..... 1.20
  - Safety Instructions ..... 1.21
  - EMC Safety Precautions ..... 1.22
  - Connecting the R&S SMJ to the AC Supply ..... 1.23
  - Switching On ..... 1.23
  - Start Display and Booting the R&S SMJ ..... 1.23
  - Switching Off ..... 1.24
- Function Check ..... 1.24
- Default Settings ..... 1.25
- Windows XP Embedded ..... 1.26
- Connecting an External Keyboard ..... 1.28
- Connecting the Mouse ..... 1.28
- Connecting an External Monitor ..... 1.29
- Connecting the R&S SMJ to a Network (LAN) ..... 1.30
  - Connection to the Network ..... 1.30
- Manual Remote Control via an External Controller ..... 1.39
  - Configuration for Manual Remote Control  
via Windows Remote Desktop Connection ..... 1.39
  - Configuration for Manual Remote Control via Ultr@VNC ..... 1.45
- Using Norton Antivirus ..... 1.52
  - Preparing the Installation of Norton Antivirus ..... 1.52

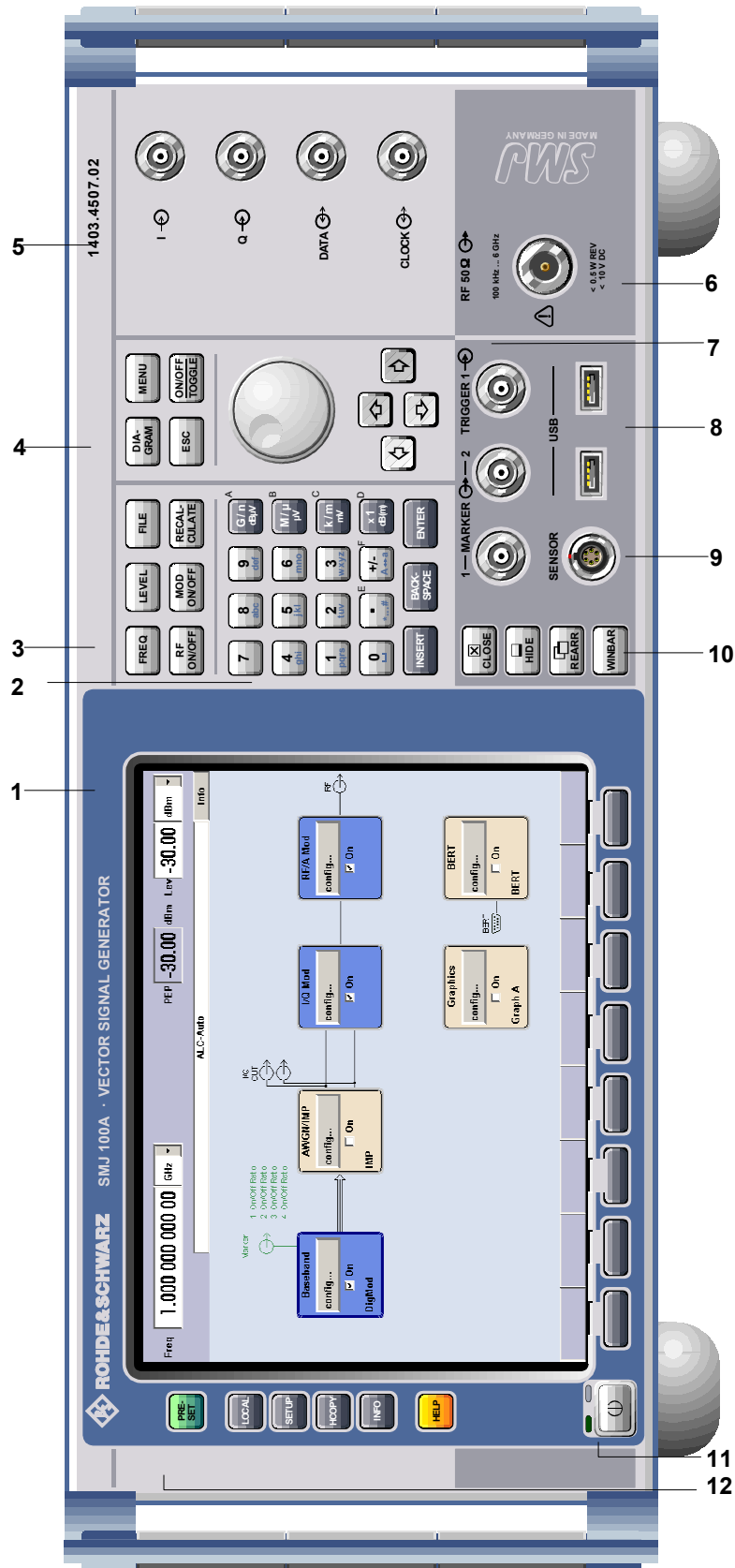

Figure 1-1 Front panel view

# 1 Putting into Operation

## Introduction - Putting into Operation

Chapter 1, "Putting into Operation" explains the control elements and connectors of the Vector Signal Generator R&S SMJ with the aid of the front and rear views and describes how to put the instrument into operation. It also describes the connection of peripherals such as printer, keyboard, mouse and monitor. A detailed description of the device interfaces is given in Chapter 8, "Maintenance and Remote Control Interfaces". Specifications of interfaces can be seen in the data sheet.

Chapter 2, "[Getting Started](#)" gives an overview of generator functions and introduces the operating concept. Detailed operating instructions and an overview of menus follow in chapter 3, "[Manual Operation](#)".

Menus and instrument functions including the associated remote control commands are described in detail in chapter 4, "Instrument Functions", basics of remote control of the instrument in chapter 5, "Remote Control - Basics" and commands for remote control in the respective chapter 6, "Remote Control - Commands". chapter 9, "Error Messages" contains a list of possible status and error messages.

## Legend for Front Panel View

This section gives an overview of control elements and connectors on the front panel of the R&S SMJ. Each element/connector is briefly described and a reference is given to the chapters containing detailed information.

### 1 Display

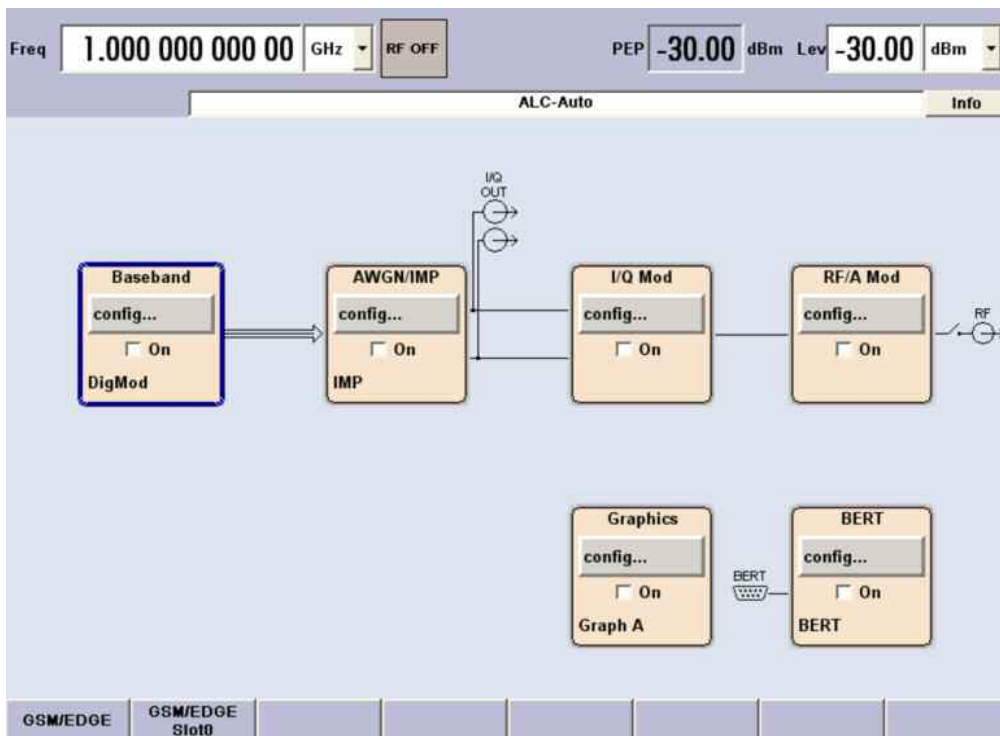

The display shows all main settings and states of the signal generator (see also chapter 3, section [Display](#), on page 3.7).

The display is divided into three sections:

- ◆ the **Status bar** with the main system parameters, level display section and an info line.
- ◆ the **Block diagram** with the current configuration.
- ◆ the **Winbar** with labelled softkeys.

### Status bar

The Status bar frequency and level display section with info line shows:

- ◆ Frequency and level settings containing offset and peak envelope power (PEP)
- ◆ Status messages
- ◆ Brief error messages (detailed information for a message can be called with the `INFO` key)

(see also chapter 3, section [Display](#), on page 3.7).

### Block Diagram

The **block diagram** shows the current configuration and the signal flow in the generator with the aid of function blocks containing an on/off switch. Clicking the function block opens a list of associated setting menus. Active menus, info windows and graphs are displayed on top of the block diagram. The block diagram can be displayed in the foreground anytime with the `DIAGRAM` key.

(see also chapter 3, section [Display](#), on page 3.7).

### Winbar

Open menus are indicated by a labelled button in the **Winbar**. The buttons determine the softkey functions for front-panel control. When a button or softkey is pressed, the associated menu is displayed either in the foreground or minimized in the Winbar.

If required, the Winbar is covered by a row of buttons to which menu-specific functions of the active menu are assigned. By pressing the `WINBAR` button, the Winbar can be displayed in the foreground again. This allows the user to toggle between the button and softkey functions.

(see also chapter 3, section [Display](#), on page 3.7).

## 2 Keypad for data entry

### Numeric and alphanumeric keys



- 0...9**  
Entry of numeric values
- .**  
Entry of decimal point
- +/-**  
Entry of sign
- abc**  
Entry of letters
- Entry of a space
- \*... #**  
Entry of special characters
- A ↔ a**  
Switchover between uppercase and lowercase letters

See chapter 3, section [Setting Parameters](#), on page 3.16.

### A, B, C, D, E, F



- A, B, C, D, E, F**  
Entry of hexadecimal values. The letters assigned to the keys are automatically active when an entry field with a hexadecimal value is active.

See chapter 3, section [Setting Parameters](#), on page 3.16.

## Insert, Back Space, Enter



### INSERT

Toggles between insert and overwrite mode.

### BACKSPACE

Deletes the character to the left of the cursor.

### ENTER

Calls the next menu level.  
 Activates the editing mode for highlighted numeric and alphanumeric parameters.  
 Terminates a data entry; the new value is set. In case of numeric parameters, the unit indicated next to the value in the menu applies.  
 Switches highlighted status parameters on and off (on/off state).  
 Confirms (OK) and closes message windows.

See chapter 3, section [Setting Parameters](#), on page 3.16.

## Unit Keys

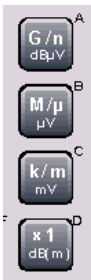

The unit keys can either select a unit and thus determine the absolute value, or change the unit, i.e. trigger a recalculation without changing the absolute value. Their function depends on the time at which they are pressed during parameter entry:

### Selecting the unit

If a unit key is pressed immediately after a numeric value has been entered, it terminates the entry and determines the multiplication factor for the respective basic unit (e.g. the k/m key determines the unit kHz after frequency entry).  
 If a level value is entered, the unit keys are directly labelled with the units they select. The level entry must be active in this case, e.g. by pressing the LEVEL key.

### Changing the unit

If a numeric entry is terminated with ENTER (e.g. by clicking the rotary knob) and not with a unit key, the unit displayed in the unit field of the parameter in the menu is assigned. If the unit key is pressed later, the unit is changed but not the value. The value is recalculated to suit the new unit (e.g. the display changes from 1000 to 1 when the Hz is changed to kHz). The new unit is then indicated in the value field of the menu.

See chapter 3, section ["Selecting a Unit - Setting Parameters"](#).

## Unit Keys - Assignment

**G/n**

Giga/nano,

**dBμV**

dBμV for RF levels, dBu for LF levels

**M/μ**

Mega/micro

**μV**

μV for levels

**k/m**

kilo/milli

**mV**

mV for levels

**x1**

basic unit (x1)

**dB(m)**

V for levels

**x1** has the same function as the **ENTER** key for unit-free values.

See section "[Selecting a Unit - Setting Parameters](#)", on page 3.22.



### 3 Keys for setting parameters

#### Frequency and level settings

**FREQ**

Activates frequency entry.

**RF ON/OFF**

Switches the RF signal on and off. **RF OFF** is displayed in the header next to the **Frequency** field.

**LEVEL**

Activates level entry.

**MOD ON/OFF**

Switches the modulations on and off. **MOD OFF** is displayed in the info line of the header next to the **Level** field.

**FILE**

Activates the menu for storing or loading files.

**RECALCULATE**

Starts the recalculation of instrument settings. If time-consuming calculations are required, the active modulation is automatically switched off and the calculation is interrupted to allow the user to make further settings. Calculation is restarted by a keystroke and the modulation is switched on again after the calculation is completed.

See chapter 3, "[Setting Parameters](#)" on page 3.16, and chapter 4, section "RF Signal and Analog Mod - A Mod-RF A"

## 4 Keys for settings and navigation in the display

### Display Keys



#### DIAGRAM

Brings the block diagram to the foreground. Active menus are minimized. Active menus are indicated by the buttons in the menu bar.

#### ESC

Calls the next higher selection level. This opens up the following functions:

- Closes the active menu if the cursor is in the top-level menu (parameter selection).  
If settings in this menu require acknowledgement by means of an **Accept** button, a query is displayed asking whether the changes made should be cancelled.
- Switches between different entry fields of a menu.
- Quits the editing mode and restores the previous value. This function is only available in the editing mode, i.e. only before an entry is confirmed or selected with Enter.
- Cancels queries in message windows.
- Shifts the entry cursor from the frequency or level display to the previously active menu, or to the previously highlighted block in the block diagram if no menu is active.

#### MENU

Calls the menu tree.

#### ON/OFF TOGGLE

- Switches highlighted elements or a function block on and off.
- Switches between two or more settings, e.g. items of selection lists. At the end of a list, the cursor is set on the first entry again.

See chapter 3, section "[Setting Parameters](#)", on page 3.16.

### Rotary Knob

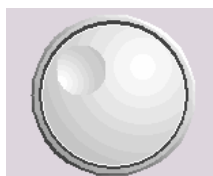

#### Rotary knob

- Varies the value at a cursor position.
- Moves the entry cursor in the block diagram or menu.
- Moves the cursor in tables and selection lists.
- Clicking on the rotary knob (= Enter). terminates entries. In this case the entry mode is terminated and the value set.

See chapter 3, section "[Setting Parameters](#)", on page 3.16.

Arrow keys



Arrow keys



- Vary the entry value.
- Highlight a selected list item in the editing mode.
- Highlight parameters in menus and tables (up/down).



- Move the cursor in the entry fields (editing mode).
- Highlight parameters in menus and tables (left/right).

See chapter 3, section "Setting Parameters", on page 3.16.

5 Analog Inputs and outputs

I/Q IN, Data and Clock

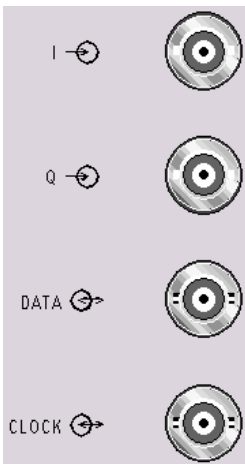

**I**

Input for external analog modulation signal in case of I/Q modulation.

**Q**

Input for external analog modulation signal in case of I/Q modulation.

**DATA**

Input for external serial data signal in case of digital modulation .

Output for serial data signal in case of digital modulation.

**CLOCK**

Input for external clock signal (bit or symbol clock, multiple of symbol clock) for synchronizing the external data signal in case of multivalent modulation. The active edge can be set.

Output for clock signal (bit or symbol clock) in the internal mode.

See data sheet and chapter 4, sections "Data and Signal Sources in Baseband", "Baseband Input Settings Menu and "Baseband Input Settings Menu".

## 6 RF output



Output for RF signal.

See data sheet.

### NOTICE Maximum Input Levels

Do not overload the RF output. The maximum permissible back-feed is specified in the data sheet.

## 7 Trigger inputs and outputs

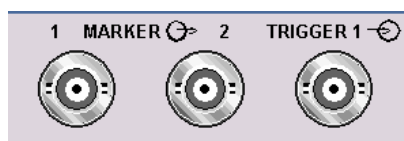

### TRIGGER 1

Input for triggering digital modulations and standards and ARB.

### MARKER 1, 2

Outputs 1 and 2 for triggering and control of external devices with user-definable marker signals.

See data sheet and chapter 4, section "Global Trigger/Clock/Input Settings – Setup - Environment".

## 8 Female USB connectors type A

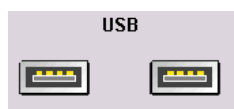

USB (universal serial bus) interfaces of type A (host USB).

- Connection of peripherals such as mouse, keyboard, printer
- Connection of memory stick for file transmission
- Firmware update

See chapter 1, section "Connecting the Mouse" and chapter 8, section "USB Connection (USB and USB IN)".

### Note:

Another USB interface type A (host USB) and a USB interface type B (device USB for data transmission and remote control) are available on the rear panel.

## 9 Connector for sensor



Connector for R&S NRP-Zxx sensors (provided for future upgrades).

With the aid of the **User Correction** function, a table with correction values for external test assemblies can be automatically determined, e.g. for compensating the frequency response of cables. The power sensors are connected by inserting the male connector. To disconnect hold the connector by its sleeve. Pulling on the sensor cable will not release the sensor connector.

## 10 Keys for setting the display



### CLOSE

Closes the active menu.

If the entry mode is active, changes are cancelled.

If settings in this menu require acknowledgement by means of an **Accept** button, a query is displayed asking whether the changes made should be cancelled.

### HIDE

Minimizes the active open menu. The associated button in the Winbar remains visible.

### REARR

Automatic rearrangement of open menus.

### WINBAR

Toggles between display and blanking of the Winbar.

See chapter 3, section "[Menu Operation](#)".

## 11 Switch



The on/off switch switches the instrument from the standby mode to the operating state provided the power switch on the instrument rear is switched on.

- ◆ The yellow LED (right) is on in the standby mode.
- ◆ The green LED (left) is on when the instrument is ready for operation.

See chapter 1, section "Switching On", on page 1.23.

### CAUTION



### Danger of shock hazard!

The instrument is still power supplied while it is in standby mode.

## 12 Keys for general instrument settings



### PRESET

Sets the instrument to a defined state.

### LOCAL

Switches from REMOTE control to LOCAL (manual) control.

### SETUP

Opens the setup menu for configuring presetting.

### HCOPI

Opens the print menu for configuring and starting printing.

### INFO

Activates the display of status messages, error messages and warnings.

### HELP

Activates the context-sensitive help display.

See chapter 4, section "General Instrument Settings"

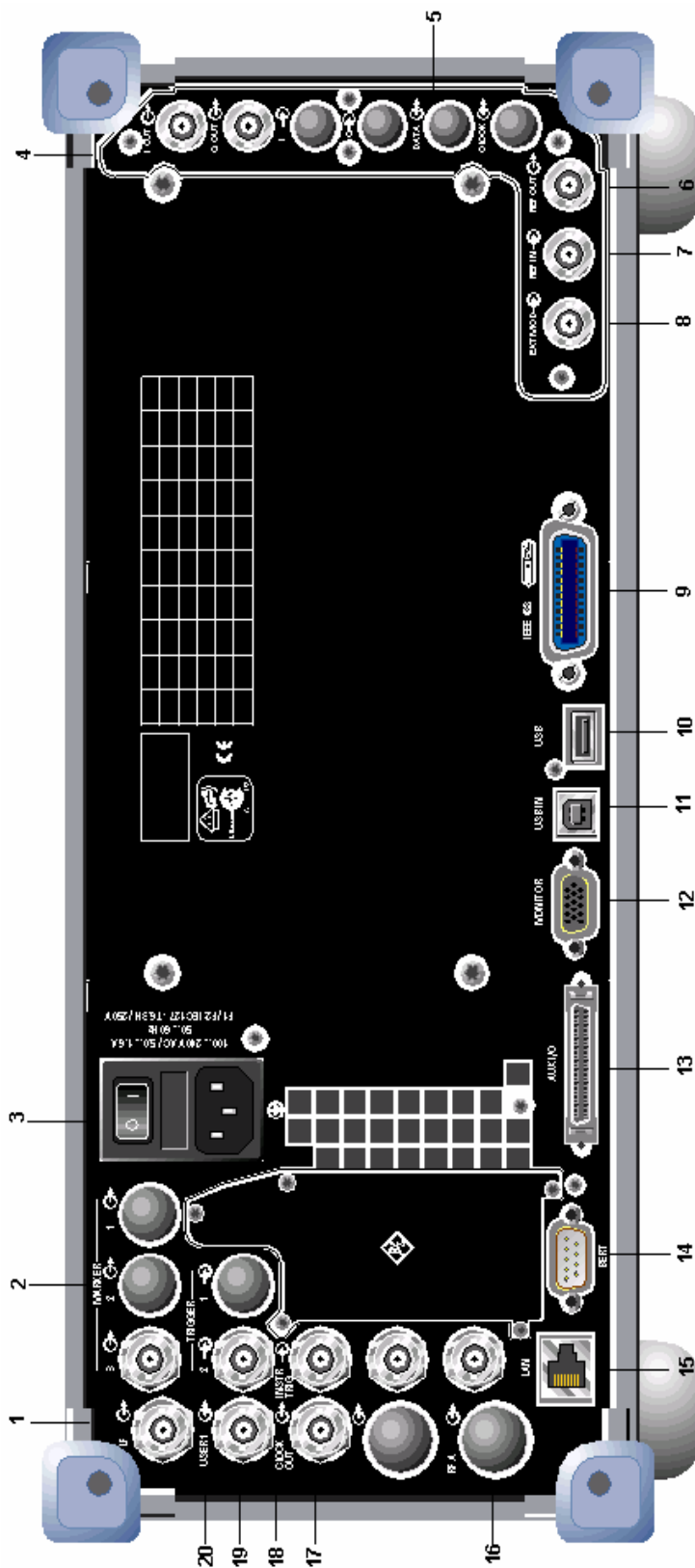

Fig. 1-2: Rear panel view

## Legend for Rear Panel View

This section gives an overview of connectors on the rear panel of the R&S SMJ. Each connector is briefly described and a reference is given to the chapters containing detailed information. For technical data of the connectors refer to the data sheet.

### 1 LF output



**LF**

Output for internal LF generator signal.

See chapter 4, section "LF Generator and LF Output - LF Output" and data sheet.

### 2 Marker output

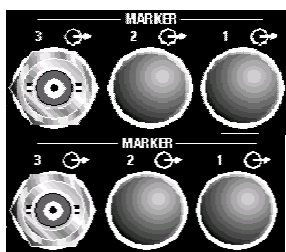

**MARKER 3**

Output for user-programmable marker signal 3 for triggering and control of external devices.

**Marker signals 1 to 3**

These marker signals are permanently **assigned** to the outputs (1 and 2 at the front, 3 at the rear); marker signal 4 can be routed to one of the four USER outputs.

**MARKER 1 and 2**

These outputs are intended for future upgrades.

See chapter 4, section "Global Trigger/Clock/Input Settings - Setup - Environment" and data sheet.

### 3 AC supply



Power switch

Power connector

**AC supply connector.**

When the R&S SMJ is connected to the AC supply, it automatically sets itself to the correct range for the applied voltage (range: see type label). There is no need to set the voltage manually or change fuses.

**Power switch.**

The R&S SMJ comes with or without a power switch, depending on the design of the otherwise technically equivalent power supply unit.

See chapter 1, section "[Connecting the R&S SMJ to the AC Supply](#)" and data sheet.



## 4 I/Q signal output



### I OUT / Q OUT

Direct output or Differential (non-inverting) output (with option R&S SMJ-B16) for analog I/Q signal.

See data sheet and chapter 4, section "Impairment of Digital I/Q Signal".

## 5 Differential I/Q signal output

### I OUT BAR / Q OUT BAR

Differential (inverting) output (Option R&S SMJ-B16) for analog I/Q signal).

See data sheet and chapter 4, section "Differential Outputs".

## 5 I/Q/DATA/CLOCK

### I/Q/DATA/CLOCK

Rear Panel Connectors (option R&S SMJ-B81). This options are recommended for use of the instrument in a 19" rack. Installing the instrument in a 19" rack requires a rack adapter or an adapter for telescopic sliders (refer to data sheet for Order No.).

See data sheet and chapter 4, section "[Setting up the Instrument or Installing it in a 19" Rack](#)".

#### **Note:**

*Option R&S SMJ-B16 (Differential Outputs) and option R&S-SMJ-B81 cannot be fitted together, because they use the same connectors.*

## 6 Reference signal output



### REF OUT

Output of internal reference signal.

See data sheet and chapter 4, section "RF Reference Frequency - Reference Oscillator".

## 7 Reference signal input



### REF IN

Input for external reference signal.

See data sheet and chapter 4, section "RF Reference Frequency - Reference Oscillator".

## 8 Input for external analog modulation signal



### EXT MOD

Input for external analog modulation signals (amplitude, pulse, frequency and phase modulation).

See data sheet and chapter 4, section "Modulation Sources".

## 9 IEC/IEEE-bus connector



### IEC 625/IEEE 488

IEC-bus (IEEE 488) interface for remote control of the R&S SMJ.

See data sheet and chapter 8, section "IEC/IEEE Bus Interface".

## 10 USB connectors type A



### USB (universal serial bus) interfaces of type A (host USB).

- Connection of peripherals such as mouse, keyboard, printer.
- Connection of memory stick for file transmission.

See chapter 1, section "[Connecting the Mouse](#)" and chapter 8, section "USB Connection (USB and USB IN)".

#### Note:

*Further USB interfaces of type A (master USB) are on the front panel.*

## 11 USB interface type B



### USB (universal serial bus)

Interface of type B (device USB).

- Input for external asynchronous modulation data.
- Remote control of signal generator.
- Software download.

See chapter 8, section "USB Connection (USB and USB IN)".

## 12 Monitor



### Monitor

Connector for external monitor.

See data sheet and chapter 1, section "Connecting an External Monitor" and chapter 8, section "Monitor Connector (MONITOR)".

## 13 AUX I/O interface

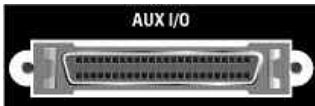

### AUX I/O

Parallel input/output for data signals as well as settable trigger and control signals of the baseband. Input for device trigger.

Assignment of the AUX I/O interface and of USER pins can be configured in the **Setup** menu under **Environment - Global Trigger/Clock/External Inputs - USER Marker / AUX I/O Settings**.

#### Note:

An adapter of the AUX I/O interface to coaxial BNC connectors is available as an accessory (R&S SMJ-Z5, see data sheet).

See chapter 4, section "Global Trigger/Clock/Input Settings – Setup - Environment" and data sheet.

## 14 BERT



### BERT (Bit Error Rate Tester) input

Input for data, clock and control signals for bit and block error rate measurements, level 0.0128..1.998V.

See data sheet and chapter 4, section "Bit and Block Error Rate Measurements - BERT Block" and chapter 8, section "BERT Connector".

## 15 LAN interface

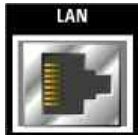

### LAN - Ethernet interface

- For integrating signal generators in a network.
- Remote control of signal generator.
- Input of external asynchronous data.
- Manual remote control of signal generator.
- Firmware update.

See data sheet and chapter 1, section "Connecting the R&S SMJ to a Network (LAN)", on page 1.30", chapter 8, section "LAN Connector" and chapter 5, section "Remote Control via LAN Interface".

## 16 RF

### Note:

*The RF connector is provided for future upgrades.*

## 17 Clock signal output



### CLOCK OUT

Output for internal (bit or symbol) clock signal.

See data sheet and chapter 4, section "Data and Signal Sources in Baseband".

## 18 Instrument triggering



### INSTR TRIG

Input for external trigger of analog modulations, sweeps and list mode. HOP input for control of the frequency hop mode with external source in the list mode.

See data sheet and chapter 4, sections "List Mode - List", and "Sweep Mode".

## 19 USER connector



### USER

Input/output for configurable signals for triggering and control.

The following signals can be applied to the connector:

- Marker 4
- CW mode Out
- No signal (blank) marker
- HOP

See data sheet and chapter 4, section "Global Trigger/Clock/Input Settings – Setup - Environment".

## 20 Trigger input



### TRIGGER 2

Input for external triggering of digital modulations and standards and ARB.

**Note:**

*The TRIGGER 1 input is provided for future upgrades.*

See data sheet and chapter 4, section "Global Trigger/Clock/Input Settings - Setup - Environment".

## Putting into Operation

The following section describes the procedure for putting of the instrument into operation and the connection of peripherals such as printer and monitor. It contains general safety instructions for instrument operation.

The installation of options and the firmware update are described in chapter 4 of the Service Manual (supplied with the instrument on the CD-ROM).

## Unpacking the Instrument

- ◆ Remove the instrument from its packaging and check the equipment for completeness using the delivery note and the accessory lists for the various items.
- ◆ First, pull off the polyethylene protection pads from the instrument's rear feet and then carefully remove the pads from the instrument handles at the front.
- ◆ Pull off the corrugated cardboard cover that protects the rear of the instrument.
- ◆ Carefully unthread the corrugated cardboard cover at the front that protects the instrument handles and remove it.
- ◆ Check the instrument for any damage. If there is damage, immediately contact the carrier who delivered the instrument. In this case, make sure not to discard the box and packing material.

It is advisable to keep the original packing material in order to prevent control elements and connectors from being damaged in case the instrument is to be transported or shipped at a later date.

## Setting up the Instrument or Installing it in a 19" Rack

The instrument is designed for indoors use. It can either be set up independently or mounted in a 19" rack. A rack adapter or an adapter for telescopic sliders (refer to data sheet for Order No.) is required for installation in a 19" rack. The mounting instructions are supplied with the adapter. With options R&S SMJ-B81 (Rear Panel Connectors, factory-fitted) the front panel inputs are relocated to the rear panel.

---

**NOTICE****Risk of overheating!**

To less airflow for cooling may cause overheating of the instrument.  
Prior to putting the instrument into operation always check for space between the ventilation holes and the rack casing to get sufficient air supply in the rack.

---

## Safety Instructions

### General Precautions

**NOTICE****Instrument damage caused by disregarding the following precautions!**

Any non-compliance with the following precautions may cause damage to the instrument. Prior to putting the instrument into operation, check the following:

- ◆ The covers of the housing are in place and screwed on.
- ◆ Vents are not obstructed. Make sure that the air can escape freely through the vents at the rear and at the sides. The minimum distance to the wall should therefore be at least 10 cm.
- ◆ The signal levels at the inputs do not exceed permissible limits.
- ◆ The outputs of the instrument are not overloaded or incorrectly connected. This particularly applies to the maximum permissible back-feed at the outputs, which is specified in the data sheet
- ◆ The instrument should only be operated in horizontal position on an even surface.
- ◆ The ambient temperature must not exceed the range specified in the data sheet.

Also observe the instructions in the following sections and the general safety instructions at the beginning of this manual.

### Protection against Electrostatics

**Risk of instrument damage caused by electrostatic discharge!**

To avoid damaging the electronic components of the EUT due to electrostatic discharge produced by contact, the use of appropriate protective measures is recommended.

## Setting up the Instrument

**CAUTION****Safe operation with support feet!**

- ◆ Stacked **instruments** may slip off.  
Secure stacked instruments against slipping (e.g. by locking the feet to the top of the front-panel frame).  
The feet must be fully folded in or folded out. Only then a stable position of the instrument and reliable operation can be ensured. The uniform pressure on the folded-out feet must not exceed 500 N (weight of instrument and of equipment stacked on top).
- ◆ When the instrument with expanded feet, the feet might collapse and fold in.  
**Do not shift the instrument with the feet out.**

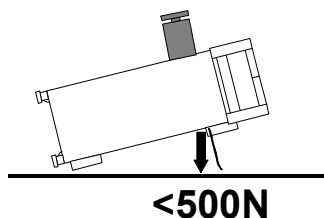

## EMC Safety Precautions

To avoid electromagnetic interference, only suitable, shielded signal and control cables must be used (see recommended extras).

## Cleaning the Outside and Storing

What is necessary is essentially the cleaning of the instrument.

**NOTICE****Instrument damage caused by cleaning agents!**

Prior to cleaning, disconnect the product from the AC supply.

Cleaning agents contain substances that may damage the instrument, e.g. solvent-containing cleaning agents may damage the front panel labeling or plastic parts.

Never use chemical cleaning agents such as solvents (e.g. diluent for lacquers, thinners, acetone, alcohol, etc), or acids, bases, or other substances.

Use a soft, non-linting cloth to suitably clean the outside of the instrument.



## Connecting the R&S SMJ to the AC Supply

The R&S SMJ is automatically matched to the applied AC voltage (see rear panel). There is no need to set the voltage manually or change fuses. The AC supply connector is at the rear of the unit (see below).

## Switching On

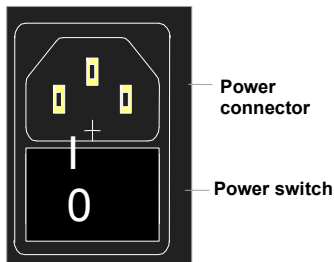

- ◆ Connect the signal generator to the AC supply by means of the supplied power cable.  
Since the instrument is designed in line with protection class EN61010-1, it may only be connected to an earthing contact type connector.
- ◆ Press the main power switch at the rear of the instrument to position I.
- ◆ After power-up the instrument is either ready for operation (STANDBY) or in operating mode, depending on the position of the ON/STANDBY switch on the instrument front (see below).

---

### Note:

*The power switch may remain on for any period of time. Switching off is required only if the instrument should be completely isolated from the AC supply.*

---

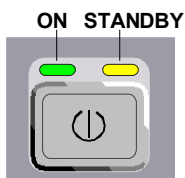

- ◆ Press the ON/STANDBY switch on the front panel; the green LED must be on.
- ◆ The instrument is ready for operation. All modules in the instrument are supplied with power.

## Start Display and Booting the R&S SMJ

After instrument switch-on, the installed BIOS version and the processor characteristics are indicated for a few seconds in the start display.

After this, the Windows XP Embedded operating system boots and then the instrument firmware. During booting of the instrument firmware, a selftest is performed. After booting is completed, the block diagram of the signal generator is displayed and the instrument is ready to be operated. The settings that were active before the last switch-off are established unless another start setting has explicitly been selected in the **File** menu.

---

### Note:

*If the software stops unexpectedly, the instrument can be rebooted by pressing the STANDBY key for approx. 5 s.*

---

## Switching Off

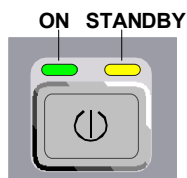

- ◆ Press the **ON/STANDBY** switch on the front panel. The R&S SMJ stores the current setting on the hard disk before it shuts down the Windows operating system. Then the AC supply is switched to the **standby** mode. Only the AC supply is powered and the oven-controlled crystal oscillator is kept at operating temperature. The yellow LED must be on.

### CAUTION



### Danger of shock hazard!

The instrument is still power-supplied while it is in standby mode.

Do the following only if the instrument is completely disconnected from the AC supply:

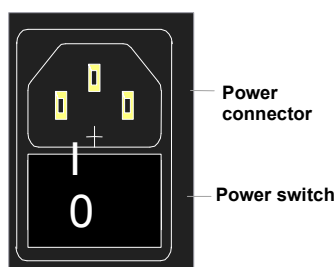

- ◆ Press the main power switch at the rear of the instrument to position **0**. None of the front-panel LEDs should be on.

#### Note:

*It is recommended to switch the instrument to **standby mode** before completely disconnecting it from the AC supply. If the power switch is set to 0 before the instrument is switched to the standby mode, all current settings are lost. Moreover, loss of program data cannot be excluded if the application is terminated improperly.*

## Function Check

The signal generator automatically monitors the main functions when the instrument is switched on and continuously during operation.

If a fault is detected, ERROR is displayed in the info line together with a brief error description.

For in-depth identification of the error, press the **INFO** key. In response, a description of the error(s) is displayed (see chapter 9, "Error Messages").

Besides automatic monitoring of instrument functions, other capabilities in the R&S SMJ ensure correct functioning of the vector signal generator.

#### ◆ Internal Adjustments

Adjustments can be performed in the **Setup-System-Internal Adjustments** menu. Thus maximum level accuracy can be obtained, for instance.

#### ◆ Test points

Internal test points can be queried by the user and the results can be displayed. See chapter 4, section "Test Point... - Setup-Test".

## Default Settings

The **PRESET** key calls up a defined instrument setup. All parameters and switching states are preset, including those of inactive operating modes. The default instrument settings provide a reproducible initial basis for all other settings. However, functions that concern the integration of the instrument into a measurement setup are not changed, e.g. IEC/IEEE bus address or reference oscillator source settings.

---

### Note:

*Resetting the instrument to the factory state is possible in the Factory Preset - Setup Settings menu of the menu.*

---

In addition, only those settings associated with the menu can be reset directly in the individual menus, e.g. all digital modulation settings in the **Custom Digital Mod** menu. These settings are identical to those which are called up using the **PRESET** key.

When the instrument is switched on, it is not the preset state that is active, but rather the instrument state that was set before the instrument was switched on.

User-defined instrument states can be stored and called up in the **File** menu.

The following table gives an overview of the presets for the most important generator settings. The other presets can be found in the preset tables of the individual dialogs and the information accompanying the IEC/IEEE-bus commands.

The list below the table shows the settings that are not affected by the **PRESET** key.

Table 1-1 Preset state - important generator settings

RF frequency	1 GHz
RF level	RF output switched off
Offsets	0
Modulations	Switched off
Uninterrupted level setting	Switch off; level attenuator mode: AUTO
Internal level control	Level ALC: AUTO
User correction	Level Ucor: OFF
LF output	Switched off
Sweep	Switched off
List mode	Switched off

Settings that are not affected by the **PRESET** key:

- ◆ Reference frequency settings (Ref Oscillator menu)
- ◆ Power on settings (Level/EMF menu)
- ◆ Network settings (Setup menu)
- ◆ IEC/IEEE-bus address (Setup menu)
- ◆ Password and settings protected by passwords (Setup menu)
- ◆ Start/Stop Gui Update (Setup menu)
- ◆ Display and keyboard settings (Setup menu).

---

# Windows XP Embedded

---

**NOTICE****Functions of the instrument may be impaired!**

The instrument is equipped with the Windows XP Embedded operating system. It is thus possible to install COTS software in the instrument. The use and installation of commercial off-the-shelf (COTS) software may impair the instrument function. For this reason, we recommend that you only execute programs tested by Rohde&Schwarz with regard to their compatibility with the instrument software.

The following program packages have been tested.

- ◆ R&S Power Viewer (virtual power meter for displaying results of the Power Sensor R&S NRP-Zxx)
- ◆ Windows XP Remote Desktop
- ◆ Symantec Norton AntiVirus – Virus-protection software

In certain cases, the use of these programs can impair the performance of the instrument.

The drivers and programs used in the instrument under Windows XP Embedded have been adapted to the test instrument. Existing instrument software must only be modified with update software released by Rohde & Schwarz.

Chapter 4 of the service manual describes how the instrument software can be restored in case of a program crash by using the recovery function. The service Manual is delivered with the instrument on the CD-ROM.

---

The signal generator is equipped with the Windows XP Embedded operating system. The configuration of the operating system is optimally adapted to signal generator functions in the factory. Changes in the system setup are only required when peripherals like keyboard and printer are installed or in the event that the network configuration does not comply with the default settings (see sections "[Connecting the R&S SMJ to a Network \(LAN\)](#)", on page 1.30).

After power-up of the signal generator, the operating system boots and the instrument firmware is started automatically without a password query (auto login).

---

**Note:**

*Auto login is performed with the user name and the password "instrument". The standard user has administrator rights so that printer and network installations are possible.*

---

The operating system can only be accessed if an external keyboard and/or a mouse is connected. Windows XP provides an on-screen keyboard that can be operated using a mouse, thus enabling operation by mouse only. An external keyboard is recommended for extensive entries.

System settings under Windows XP can be made in the **Start - Control Panel** menu (for required settings refer to the Windows XP manual and to the hardware description).

The Windows XP start menu is opened with the **Windows** key (next to the Ctrl key) or with key combination CTRL-ESC on the external/on-screen keyboard. In this menu the Windows XP programs can be called.

Some of the programs are also placed as symbols on the Windows task bar and can be called directly by double-clicking the associated symbol. The Windows XP desktop including the task bar is displayed when moving the mouse to the bottom of the display.



The instrument display with block diagram, header and Winbar is displayed in the foreground by double-clicking the **Block Diagram**, **Status Bar** and **Task Bar** buttons in the Windows task bar.

The R&S SMJ does not contain a disk drive. Data is exchanged via a memory stick connected to a USB interface. An unused disk drive letter is automatically assigned to the memory stick. Data can be transferred in Windows Explorer.

**Energy saving mode:**

An energy saving mode is a default setting in the R&S SMJ. The hard disk switches to power-save mode if it is not accessed for 30 minutes. The energy-saving mode is exited by accessing the hard disk anew.

## Connecting an External Keyboard

A commercial, external keyboard with USB interface can be connected to the R&S SMJ. A keyboard simplifies entry of list items, comments, file names, etc. and is a prerequisite for convenient operation of Windows XP.

The keyboard is connected to a USB interface, type A, on the front or rear panel of the instrument.

1    USB    2



The keyboard is detected automatically shortly after connection. The US keyboard assignment is the default setting.

---

**Note:**

*The keyboard assignment and special settings such as the refresh rate can be changed in the **Start - Control Panel - Keyboard** or **Regional and Language Options** menu of Windows XP. The menu can be accessed by pressing the **Windows** key on the external keyboard.*

---

---

**Note:**

*A keyboard emulation menu can be called from the Window XP operating system (START - Programs - Accessories - Accessibility - On-Screen Keyboard). With the On-Screen Keyboard it is possible to manually operate the instrument using the mouse only.*

---

## Connecting the Mouse

A commercial mouse with a USB interface can be connected to the R&S SMJ. A mouse simplifies control of the block diagram and of associated menus. It is sufficient for operation of Windows XP when used together with the on-screen keyboard.

The mouse is connected to one of the USB interfaces on the front or rear panel of the instrument.

1    USB    2



The mouse is detected automatically when it is connected. Special settings such as mouse cursor speed etc. can be made in the **Start - Control Panel - Mouse** menu of Windows XP. The menu can be accessed by pressing the **Windows** key on the keyboard.

## Connecting an External Monitor

**NOTICE****Overvoltage hazard for the monitor and the R&S SMJ!**

Connecting a monitor while the instrument is switched on the monitor and instrument may be impaired.

A monitor **must not be connected** until the instrument is **switched off** (standby).

**Do not modify the screen driver** (Display type) and the display configuration since this will impair instrument operation.

An external monitor with an analog interface can be connected to the MONITOR connector on the rear panel of the R&S SMJ.



(rear panel)

**Connection**

1. Switch off the instrument (standby mode) before connecting an external monitor (see also section "[Switching Off](#)", on page 1.24) The yellow LED must be on.
2. Plug in the monitor connector to the monitor connector on the rear panel of the instrument.
3. Switch on the instrument (ON mode) to start the R&S SMJ.

After connection, the external monitor is detected automatically when the instrument is started.

The generator screen with all elements, e.g. block diagram, Winbar, etc, is then displayed on the external monitor and on the R&S SMJ.

Further settings are not required.

**Note:**

*The MONITOR interface is described in chapter 8, section "Maintenance and Interfaces".*

## Connecting the R&S SMJ to a Network (LAN)

The R&S SMJ is equipped with a network interface and can be connected to an Ethernet LAN (local area network).

Provided the appropriate rights have been assigned by the network administrator and the Windows XP firewall configuration is adapted accordingly, files can be transmitted via the network, and network resources, e.g. a network folders, can be used. The instrument can also be remote-controlled and manually controlled in the network.

Manual network control means that the user can operate the R&S SMJ from any remote PC in the network via the **Remote Desktop Connection** which is provided for Windows PCs or via the **Ultr@VNC** connection which is provided for Linux/Unix and Windows PCs. For instance, the user can control one or more R&S SMJs from a desk that is part of a test assembly located in another section of the building.

Remote-control of the instrument via the LAN interface is described in chapter 5, section "Remote Control via LAN Interface".

A firmware update via the LAN interface is described in chapter 2 of the service manual (on CD-ROM).

## Connection to the Network

---

### NOTICE

#### Risk of network errors!

Connecting errors may affect the entire network.

We recommend coordinating the connection of the instrument to the network with the network administrator.

**Do not connect or disconnect** the network cable until the instrument is **switched off** (standby). Only then the network connection can be reliably detected and impairments to instrument operation can be avoided.

---

### LAN interface

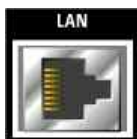

(rear panel)

### Connection

The instrument is connected to the LAN with the aid of a commercial RJ-45 cable suitable for a 10/100/1000Mbps connection attached to the LAN interface at the rear of the instrument.

Connect the instrument to the LAN interface on the rear panel of the instrument.

---

#### Note:

*The LAN interface is described in chapter 8, section "Maintenance and Interfaces".*

---



## Configuring the R&S SMJ for Network Operation

The network interface functions with 10/100/1000Mbps Ethernet IEEE 802.3u. The TCP/IP network protocol and the associated network services are preconfigured.

For data exchange in a LAN, each connected PC or instrument must be accessible via an IP address or via an unambiguous computer name. In addition, network access of the different users is organized by the assignment of access rights.

Access rights determine which of the available network resources, e.g. data logging systems, are available to the R&S SMJ.

The Windows XP operating system is protected by an activated firewall per default. The configuration of the firewall has to be adapted according to the required network communication needs.

### Networks using DHCP

The R&S SMJ is preconfigured for networks using DHCP (dynamic host configuration protocol). In these networks, an available IP address is automatically assigned to the R&S SMJ. In this case the generator is identified via an unambiguous computer name in the network.

Each R&S SMJ is assigned a individual computer name in the factory. This name can be queried and changed in the **Start - My Computer** menu of Windows XP (see "[Query Computer Name](#)" below).

### Networks using fixed IP addresses

In networks using fixed IP addresses, the addresses are mostly assigned by the network administrator. A fixed IP address must be entered in the **Start - Control Panel** menu of Windows XP (see "[Entering the IP Address](#)" below).

### Point-to-Point Connection

To build a simple network – just an LAN connection between the R&S SMJ and a controller without integration into a larger network – an IP address has to be assigned to the R&S SMJ and the controller. For such purposes, the IP addresses 192.168.xxx.yyy are available. The value range for xxx and yyy is 1...254, the value for the subnet mask is always 255.255.255.0.

For this type of connection, a commercial cross-over RJ-45 cable is used.

### User name and pass word

The user "**instrument**" is assigned to the R&S SMJ. The user name is used for auto-login when the instrument is started and for manual remote-control. The password is also "**instrument**". By assigning the respective rights, the network administrator decides which directories and resources in the network can be accessed by the R&S SMJ.

## Preparations

The configuration of the R&S SMJ for networking is performed in the Windows XP embedded menus. The operating system can only be accessed if an external keyboard and/or a mouse is connected. Operation by mouse only without the external keyboard is possible if the on-screen keyboard is used. To ensure recognition of the external devices, the instrument has to be switched off prior to connecting them.

1. Switch off instrument
2. Connect external keyboard and/or mouse to the USB interface.
3. Switch on instrument

## Entering the IP Address

1. Open the start menu (either by pressing the **Windows** key (on the keyboard next to the Ctrl key) or by moving the mouse to the bottom of the display and subsequent clicking on **Start**).



2. Click Control Panel.  
The **Control Panel window** is displayed.



- Click on Network and Internet Connections.  
The **Network and Internet Connections** window is displayed.

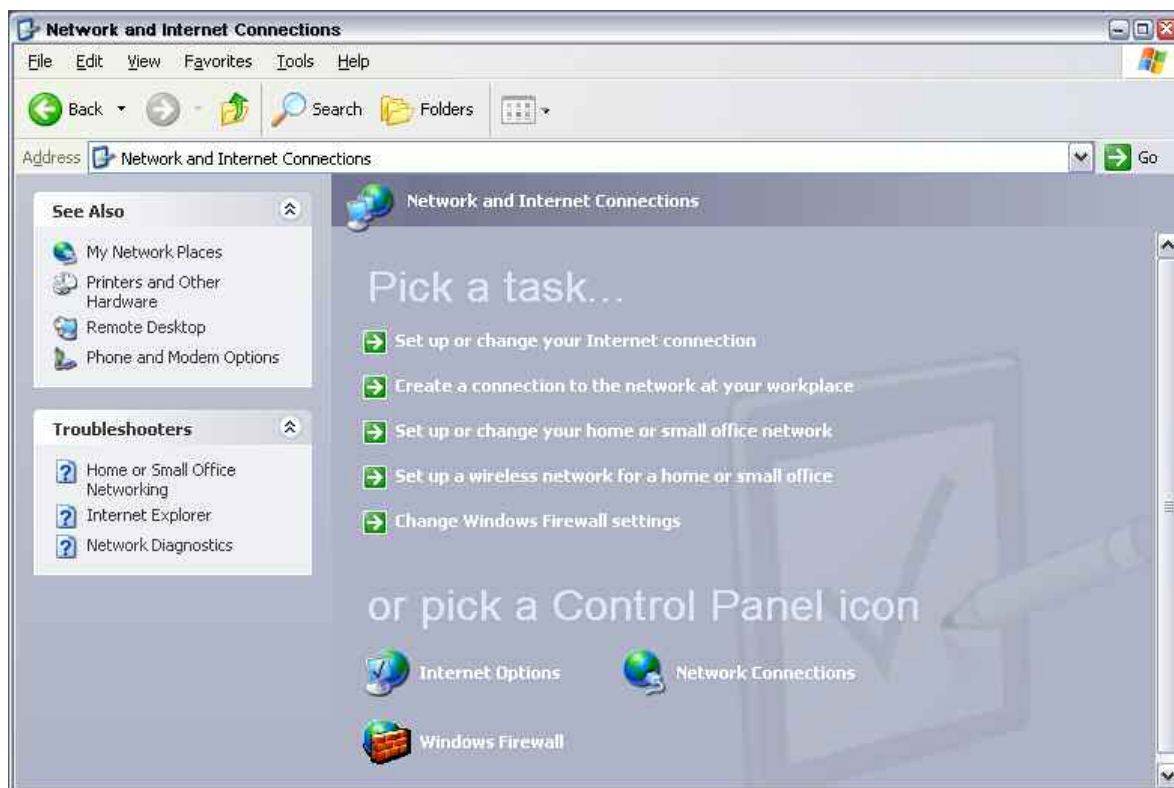

- Click on Network Connections in the menu of "pick a Control Panel icon".  
The **Network Connections** window is displayed

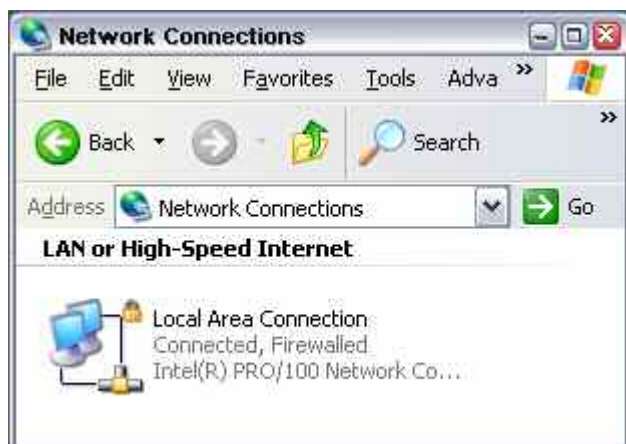

- Click on Local Area Connection in the Network Connections menu.  
The **Local Area Connection Properties** window is displayed.

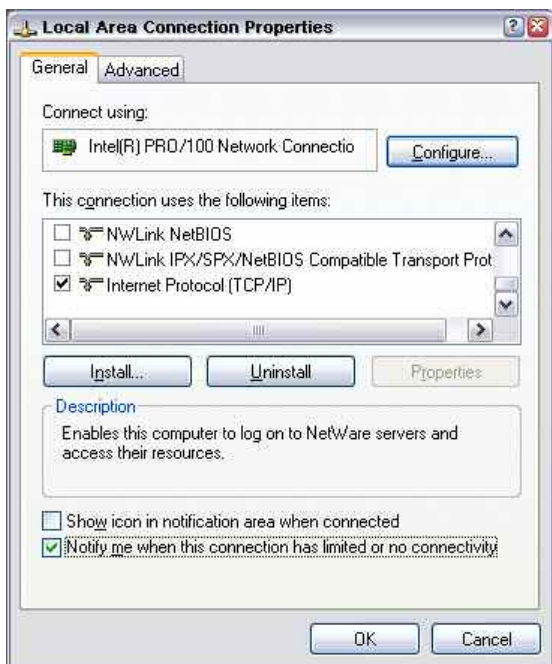

- On the General tab, select Internet Protocol (TCP/IP) in the field „This connection uses the following items:”
- Click on the **Properties** button.  
The **Internet Protocol TCP/IP) Properties** window is displayed  
Default setting is “**Obtain an IP address automatically** (DHCP = dynamic host configuration protocol)”.

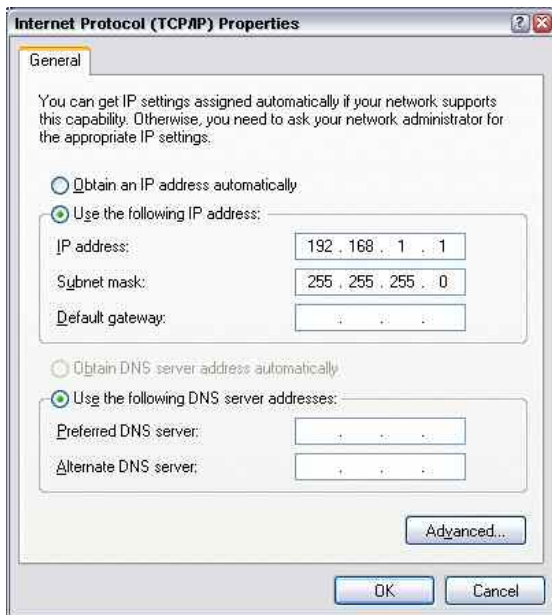

- Enter the IP address in the field “**Use the following IP address:”**  
(the IP address can be queried from the network administrator).
- Confirm the entry in all following dialogs with **OK**.

## Query Computer Name

1. Open the start menu (either by pressing the **Windows** key (on the keyboard next to the **CTRL** key) or by moving the mouse to the bottom of the display and subsequent clicking on **Start**).
2. Select My Computer.
3. Open the context menu by pressing the right mouse key.



4. Click on Properties
5. The **System Properties window** is displayed



6. Select the **Computer Name** tab.  
The computer name is displayed under "**Full Computer Name:**".  
The name can be changed in the submenu "**Change**".

## Configuring Internet Connection Firewall

The Windows XP Firewall suppresses all network communication which is not initialized by the controller itself or which is defined as unwanted. It protects the controller from an attack of hostile users and programs. On the R&S SMJ, the Internet Connection Firewall (ICF) is activated for all network connections per default to enhance protection of the instrument.

To enable data transfer with other controllers in a local network, file and printer sharing must be specifically permitted.

1. Open the start menu (either by pressing the **Windows** key (on the keyboard next to the **CTRL** key) or by moving the mouse to the bottom of the display and subsequent clicking on **Start**).



2. Select **Control Panel** and open the context menu by pressing the right mouse key.
3. Click on Switch to Classic View
4. Select the Windows Firewall

The **Windows Firewall window** is displayed.



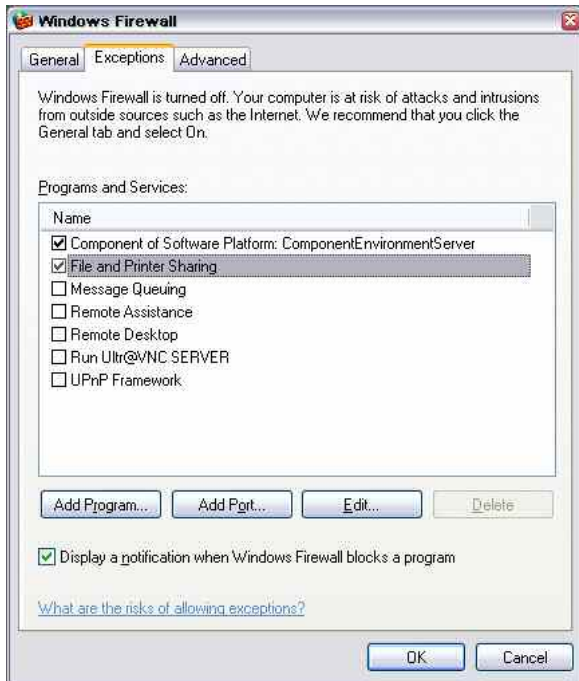

5. Select tab **Exceptions**.

6. Activate the check box “File and Printer Sharing”.
7. Confirm the entry in all following menus with **OK**.

## Accessing Directories in the Network

Access to network drives depends on access rights and whether the drives in question have been enabled. The complete integration of the R&S SMJ into a larger network with the necessary allocation of rights is highly complex and normally performed by a network administrator.

However, the hard disk of a computer also connected to the network can be accessed from the R&S SMJ relatively easily. The only precondition for this is that the desired directory the R&S SMJ should access is enabled on the remote computer. Subsequently, this directory is accessed from the R&S SMJ using a Windows XP® search function.

This procedure is also of importance for a point-to-point connection, for instance in order to start a firmware update for which the files have been stored on the hard disk of the remote computer.

---

### Note:

*The computer and the signal generator must both be equipped with a computer name and an IP address (see section "Configuring the R&S SMJ for Network Operation").*

---

**Enabling the desired directory on the remote computer**

---

**Note:**

*The menu name may deviate from the name specified in the operating sequence, depending on the language and on the operating system used on the computer.*

---

1. Open the **Windows explorer** on the remote computer.
2. Select the directory to be enabled.
3. Open the context menu by pressing the right mouse key.
4. Click on **Properties**.
5. In the **Sharing** tab, activate the checkbox "**Share this folder**".
6. Write down the name of the computer (see section "[Query Computer Name](#)").

**Accessing the enabled directory on the R&S SMJ**

1. Open the Start menu.
2. In the **Search** menu, select **Computers or People**
3. Select **A Computer on the Network**.
4. Enter the computer name in the input window of the query **Which Computer you are looking for?**
5. Start the search by pressing the enter key.  
The computer and its name appears in the results list.
6. Click on the computer's name to display the enabled directory.  
The files in this directory can be used in the R&S SMJ.

**Note:**

*If a user name and password are requested when you click the computer, the login name and password used on the computer must be entered.*

---



## Manual Remote Control via an External Controller

The R&S SMJ can be manually controlled from an external PC via a network link. This allows convenient operation of the vector signal generator from the desktop although the instrument is integrated in a rack somewhere else.

**Manual remote control** in contrast to **remote control** does not use remote-control commands but a separate software which is installed on the external PC. After its start, the software simulates the user interface of the R&S SMJ. The instrument can thus be manually operated from the PC as on the unit itself.

A precondition for manual remote control is a connection between signal generator and PC via a LAN network and the installation of the software on the PC and on the R&S SMJ.

Two free-of-charge programs are available for setting up the connection for manual remote control:

The Windows program **Remote Desktop Connection** for PCs with Window operating system and the program **Ultr@VNC** for PCs with Linux/Unix or Windows operating system.

After the connection is established, the signal generator screen with the block diagram is displayed on the external PC and the R&S SMJ can be manually remote-controlled from the external PC. The individual functions are operated using the mouse and keyboard. Specific instrument functions can be executed using specific key combinations on the keyboard or a front panel key emulation that can be operated with the mouse (see chapter 3, section "[Legend of Front-Panel Controls](#)", on page 3.44).

Installation of the remote-control software and establishing the connection between external PC and signal generator is described in the following.

### Configuration for Manual Remote Control via Windows Remote Desktop Connection

The instrument is operated with the aid of the Windows program **Remote Desktop Connection** which is provided by Microsoft in the download area of the Internet (<http://www.microsoft.com>). Manual remote-control is described in chapter 3, "[Manual Operation](#)", on page 3.1.

Manual remote control of the signal generator is possible under the following conditions:

- ◆ The Windows 95 operating system or higher and the **Remote Desktop Connection** program are installed on the external PC and a LAN interface is configured for the network.
- ◆ The signal generator and PC are linked via a LAN.
- ◆ The **Remote Desktop Connection** is enabled on the R&S SMJ
- ◆ R&S SMJ data (IP address or computer name of R&S SMJ in the network) is entered in the **Remote Desktop Connection** program of the external PC.
- ◆ Login on the external computer for the R&S SMJ was carried out with the correct user name (remote) and the correct password (remote).

**NOTICE****Risk of unauthorized access!**

After activation of the remote desktop, any user on the network who knows the computer name and login data can access this R&S SMJ. Even after cutting it, the connection is still enabled and the R&S SMJ can be accessed any time.

To disable the connection, the **remote desktop must be deactivated** on the R&S SMJ.

**Enable Remote Desktop Connection on R&S SMJ**

The configuration is performed in the Windows XP embedded menus. The operating system can only be accessed if an external keyboard is connected. A mouse is recommended for convenient operation of Windows XP. To ensure recognition of the external devices, the instrument has to be switched off prior to connecting them.

1. Switch off instrument
2. Connect external keyboard and mouse to the USB interface.
3. Switch on instrument
4. Open the start menu with the **Windows** key
5. Select **My Computer**
6. Open the context menu by pressing the right mouse key.



7. Click on **Properties**.

The **System Properties** window is displayed.

8. Select the **Remote** tab.9. Activate check box: “**Allow users to connect remotely to this computer**”.

The computer name is displayed under “Full Computer Name:”.

The name can be changed in the submenu “Change”.

**Note:**

*When activating/locking the Remote Desktop, the associated firewall settings are automatically enabled/disabled.*

## Install Remote Desktop and Establish Connection on the Windows PC

The **Remote Desktop Connection** program of Microsoft is available on the Internet for the Windows 95™ operating system and its successors as a free-of-charge download. Following the instructions on the Internet, it can be loaded onto any external PC. For the Windows XP operating system, the program is available on the installation CD-ROM.

1. Install **Remote Desktop Connection** program if required**Note:**

*Prior to the first use, the instrument and user ID of the R&S SMJ must be entered on the external PC. The instrument ID, i.e. the computer name of the R&S SMJ, identifies the R&S SMJ in the network. Each R&S SMJ is assigned a computer name in the factory, which can be used for manual remote control. The query for the computer name is described in section “[Query Computer Name](#)”, on page 1.35.*

*The user ID is required for accessing the R&S SMJ. On the R&S SMJ “**instrument**” is preset as the user name and password. No entry need be made in the **Domain** field.*

2. Start program in the **Start - All Programs - Accessories - Communications** window.  
The **Remote Desktop Connection** window is displayed.



3. Enter the computer name.
4. Click on **Options** for entering the instruments ID.  
The **Remote Desktop Connection** window (General tab) is displayed.



5. On the **General** tab, insert the **User name** and **Password** of the R&S SMJ.
6. The Login data can be stored with the **Save As** button, e.g. as default.rdp file.

**Note:**

*If the connection settings are stored as a **default.rdp** file, the login data are offered as default values by starting the program. In case the connection settings are stored in another file, the R&S SMJ link is available in a selection list, opened with the  button of the **Computer:** entry field*

7. Select **Display** tab.

The **Remote Desktop Connection window** (Display tab) is displayed

8. Select **800 x 600** by using the slide “**Remote desktop size**”.9. Confirm the connection with **Connect**.

The connection for desktop remoting is established.

After the connection is established, the signal generator screen with the block diagram is displayed and the R&S SMJ can be manually remote-controlled from the external PC.

The individual functions are operated using the mouse and keyboard. Specific instrument functions can be executed using specific key combinations on the keyboard or the front panel key emulation that can be operated with the mouse (see table in chapter 3, section "[Legend of Front-Panel Controls](#)", on page 3.44).

The device firmware of the R&S SMJ is disabled when the connection is set up. **Direct control on the R&S SMJ is not possible while manual remote-control is active.** The access of an external PC is indicated by the logon screen of Windows XP Embedded which identifies the accessing user.

If several R&S SMJ instruments are to be manually remote-controlled from one PC, a separate **Remote Desktop Control** window must be opened for each R&S SMJ. This is possible by starting the program on the external PC several times.

## Cut Manual Remote Control Connection via Remote Desktop

The connection can be cut either on the R&S SMJ or on the external PC. Cutting the connection does not disable it. It can be established again any time.

### Cutting the connection on the signal generator (requires external keyboard and mouse):

1. Click **Disconnect** in the remote-control message menu of the R&S SMJ.  
The connection is cut, a message on the external PC informs about the disconnection.

### Cutting the connection on the external PC:

1. Open the start menu.
2. Click **Disconnect** in the lower right-hand corner of menu



## Disable Manual Remote Control Connection via Remote Desktop

The connection can be disabled by deactivating the Remote Desktop on the R&S SMJ .

1. Open the start menu, select **My Computer** and open the context menu by pressing the right mouse key.
2. Click **Properties** and select the **Remote** tab in the menu.
3. Deactivate check box **Allow users to connect remotely to this computer** and close window with the **OK** button.

The connection is disabled, it is no longer possible to access the R&S SMJ for manual remote control via **Remote Desktop**.

## Configuration for Manual Remote Control via Ultr@VNC

The instrument is operated with the aid of the program **Ultr@VNC**. The program is included in operating system Linux/Unix. It is available as a free-of-charge download on the internet for operating system Window XP (<http://ultravnc.sourceforge.net/download.htm>).

Manual remote control of the signal generator is possible under the following conditions:

- ◆ The external PC with Linux/Unix or Windows operating system (Windows 95 or higher) is equipped with a LAN interface which is configured for the network.
- ◆ The signal generator and PC are linked via a LAN.
- ◆ The **Ultr@VNC** program is installed and enabled on the R&S SMJ, and an user-specific password for the **VNC** connection is defined. Communication on the network via **Ultr@VNC** program is enabled in the firewall.
- ◆ PC with Linux/Unix operating system  
The R&S SMJ IP address is entered in the **address line** of the internet browser of the external PC and the user-specific password for the **VNC** connection is entered in the request panel.
- ◆ PC with Windows operating system  
The **Ultr@VNC Viewer** program component is installed on the external PC  
R&S SMJ IP address and the user-specific password for the **VNC** connection are entered in the **VNC Viewer** panel.

---

**NOTICE****Risk of unauthorized access!**

After enabling the VNC connection, any user on the network who knows the password and IP address of the I/Q modulation generator can access this R&S SMJ. Even after cutting it, the connection is still enabled and the R&S SMJ can be accessed any time. To disable the connection, the **VNC program on the R&S SMJ must be uninstalled or the VNC server service disabled.**

To enhance security, also communication on the network via Ultr@VNC program should be disabled in the firewall.

---

## Install and Enable VNC Connection on R&S SMJ

The **Ultr@VNC** program is available on the Internet as a free-of-charge download. Following the instructions on the Internet, it can be copied onto the R&S SMJ.

1. Download the program from the internet and copy it to a directory that can be accessed by the R&S SMJ.
2. Switch off instrument.
3. Connect a mouse and a keyboard.
4. Switch on instrument.
5. Shut down firmware using the ALT-F4 key combination.
6. Start installation by double clicking the setup file (Ultr@VNC\_100\_RC18\_setup.exe / whereas 18 denotes the version number).

The setup wizard leads through the installation. In the following only those panels are described in which defined settings are required for the signal generator.



a) Select installation of all components

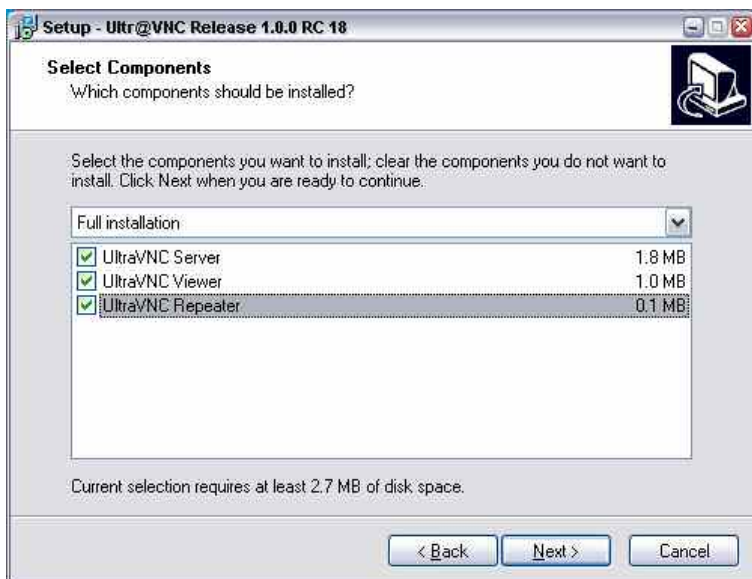

b) Select all entries in the Additional Task Panel.

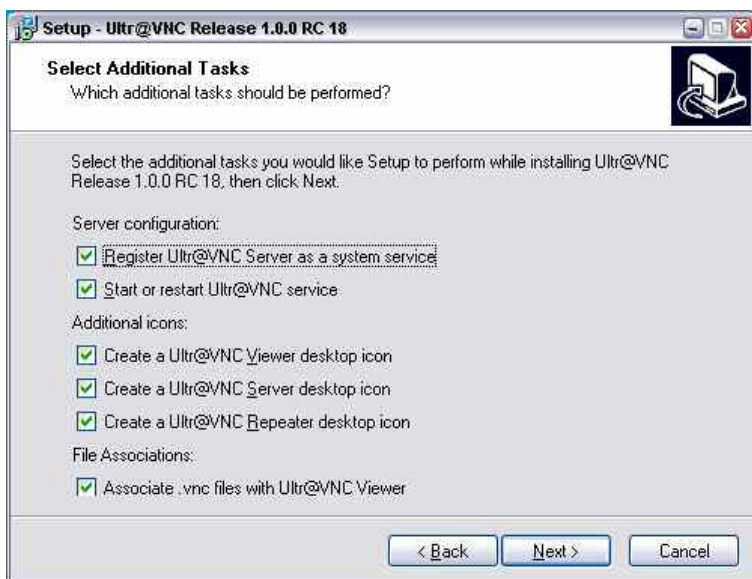

A successful installation is indicated by a message.







At the same time a warning is displayed stating that a password must be set.

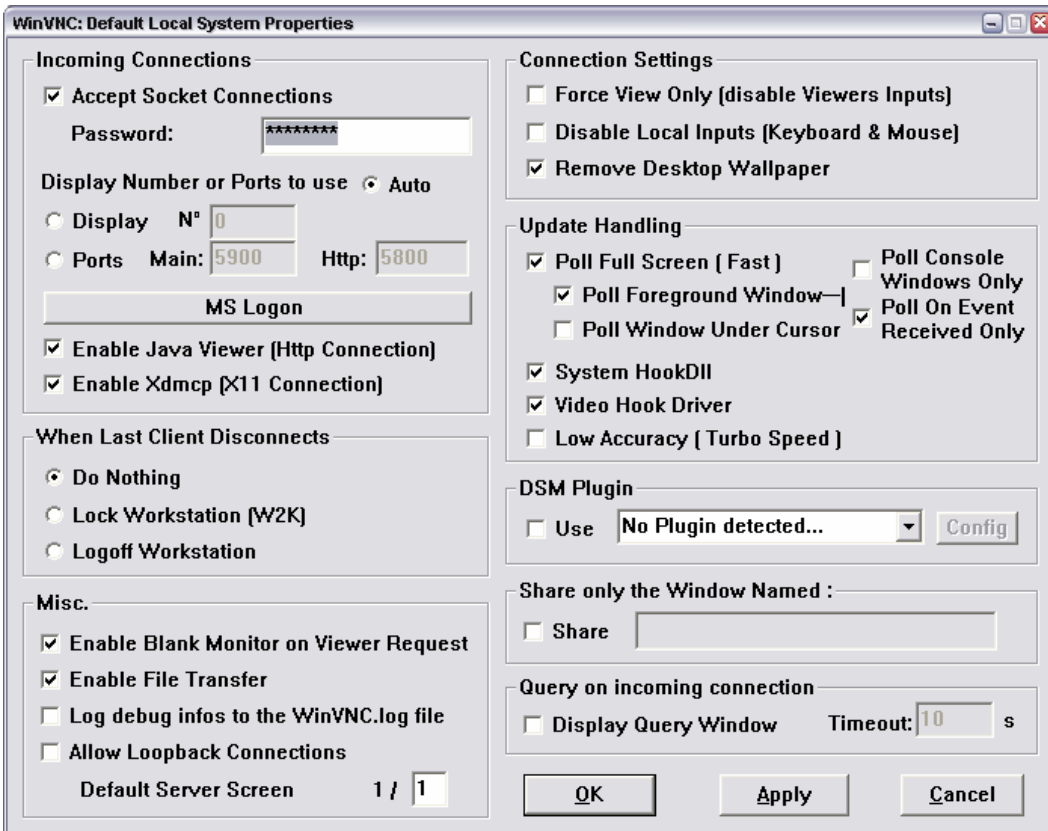

After clicking **OK** in the warning panel the **Default Local System Properties** panel opens. A password with a length of at least five digits must be entered. This password is used on the remote PC to access the R&S SMJ. Other settings may be changed according to the user-specific security requirements.



After the installation the VNC connection must be enabled in the ICF firewall (see following section).

After the installation the program always is automatically started together with the operating system. An icon  is placed on the right side of the Windows XP task bar (notification area). On mouse over, the IP address of the R&S SMJ is indicated. This IP address and the user-defined password are the prerequisites to enable manual remote control on the PC.

A cut connection is indicated by changed color of the icon. Cutting the connection does not disable it. It can be established again any time.

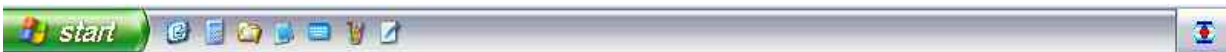

## Configuring Internet Connection Firewall for VNC Connection

To enable manual remote control by other controllers in a local network via VNC connection, the connection must be specifically permitted in the firewall.

1. Open the start menu, select **Control Panel** and open the context menu by pressing the right mouse key.
2. Click on Switch to Classic View
3. Select the Windows Firewall  
The **Windows Firewall window** (General tab) is displayed.



4. Select tab **Exceptions**.
5. Call sub menu Add Program...  
The **Add a Program window** is displayed.



6. Select **Run Ultr@VNC SERVER** and click on **OK**.  
The **Windows Firewall** window (Exceptions tab) is displayed.

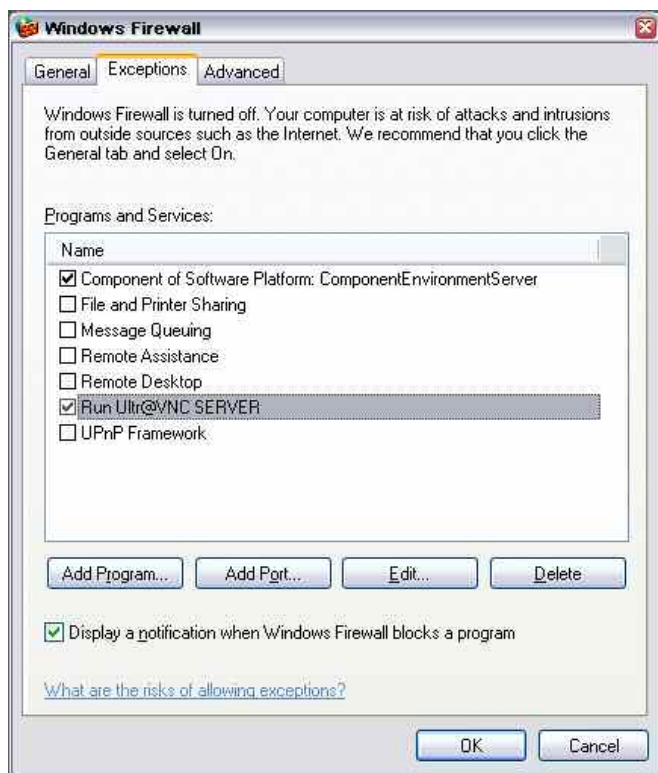

7. Activate check box **Run Ultr@VNC SERVER** in the **Exceptions** tab.
8. Confirm the entry with **OK**.

## Establish Manual Remote Control on the Linux/Unix PC

The **VNC** program is available per default for Linux/Unix operating systems. Only three steps are necessary to establish the connection to the R&S SMJ:

1. Start the internet browser on the PC.
2. Enter the following address:  
vnc://IP-address of R&S SMJ", e.g. vnc://192.168.1.1  
After Enter, the password for the remote **VNC** connection is requested
3. Enter the password defined in the **Default Local System Properties** panel of the **Ultr@VNC** program of R&S SMJ. The connection is established when the **Log On** button is pressed.

After the connection is established, the current signal generator screen with the block diagram is displayed and the R&S SMJ can be manually remote-controlled from the external PC. The individual functions are operated using the mouse and keyboard. Specific instrument functions can be executed using specific key combinations on the keyboard (see table in chapter 3, section "[Legend of Front-Panel Controls](#)", on page 3.44). In contrast to Remote Control Desktop, **direct control on the R&S SMJ is possible while manual remote-control is established**, it can be performed alternately with the manual remote control.

## Install VNC Viewer and Establish VNC Connection on the Windows PC

The **Ultr@VNC** program is available on the Internet as a free-of-charge download.

Following the instructions on the Internet, the program can be copied onto the external Windows PC. Only the program component **VNC Viewer** is required.

### Note:

The **VNC Viewer** program is included in the download for the installation of the **Ultr@VNC** program on the signal generator if **Full installation** was selected in the **Select Component** panel. In this case, the program `ultr@vncviewer.exe` can be copied to the Windows PC.

1. Install **VNC Viewer** program component on the PC.
2. Start **VNC Viewer** program component on the PC.

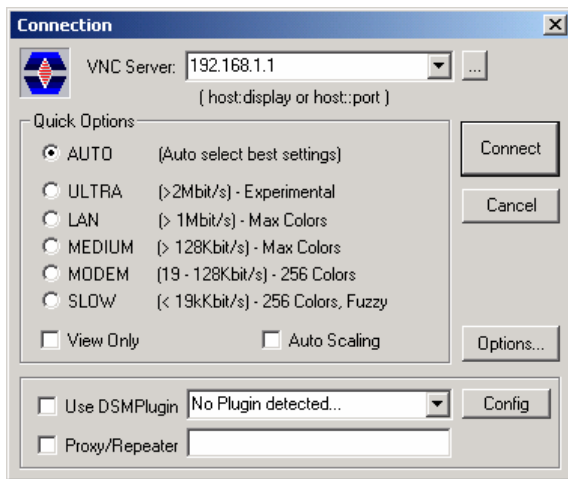

3. Enter IP address of R&S SMJ in input line **VNC Server**.
4. Initialize the connection by pressing the **Connect** button.  
A message requesting the password appears.



5. Enter the **VNC** password defined in the **Default Local System Properties** panel of the **Ultr@VNC** program of R&S SMJ.  
The connection is established when the **Log On** button is pressed.

After the connection is established, the current signal generator screen with the block diagram is displayed and the R&S SMJ can be manually remote-controlled from the external PC. The individual functions are operated using the mouse and keyboard. Specific instrument functions can be executed using specific key combinations on the keyboard (see table in chapter 3, section "[Legend of Front-Panel Controls](#)", on page 3.44). In contrast to Remote Control Desktop, **direct control on the R&S SMJ is possible while manual remote-control is established**, it can be performed alternately with the manual remote control.

## Cut Manual Remote Control Connection via Ultr@VNC

The connection can be cut either on the R&S SMJ or on the external PC. Cutting the connection does not disable it. It can be established again any time.

### Cutting the connection on the signal generator (requires external keyboard and mouse):

1. Open the start menu with the **Windows** key or the **CTRL** + **EXC** key combination.
2. Right-click on the **VNC** icon on the task bar. The context menu opens.
3. Select **Kill all clients**

The connection is cut, a message on the external PC informs about the disconnection. The **VNC** icon  changes color.

### Cutting the connection on the external Linux/Unix PC:

1. Either close the internet browser or close the signal generator window.  
The connection is disabled, the **VNC** icon on the task bar  off the R&S SMJ changes color.

### Cutting the connection on the external Windows PC:

1. Close the **VNC Viewer** program.  
The connection is cut, the **VNC** icon on the task bar  off the R&S SMJ changes color.

## Disable Manual Remote Control Connection via Ultr@VNC

The connection can be disabled by removing the program on the R&S SMJ or by deactivating the **VNC Server** service in the Control Panel.

### Removing the VNC program:

1. Open the start menu with the **Windows** key or the **CTRL** + **EXC** key combination.
2. Open the **Control Panel** menu
3. Select **Add or Remove Programs**
4. Remove the **VNC** program.

The connection is disabled, the **VNC** icon on the task bar  of the R&S SMJ disappears.

### Deactivating the VNC Server service:

1. Open the start menu with the **Windows** key or the **CTRL** + **EXC** key combination.
2. Open the Control Panel menu
3. Select **Services**
4. Deactivate the **VNC Server** service.

The connection is disabled, the **VNC** icon on the task bar  of the R&S SMJ disappears.

## Using Norton Antivirus

Virus-protection software Symantec Norton Antivirus 2005 has been successfully tested for compatibility with the measurement instrument software on R&S SMJ.

However, Norton Antivirus may affect the behaviour of the instrument in terms of settling time or stability. Norton Antivirus 2005 has been subjected to detailed tests with R&S SMJ Firmware version V1.40 and the paging file settings given below. The system remains very reliable. However, rare impact on the settling time has been experienced (slight degradations of settling time in 2% of samples out of specification).

## Preparing the Installation of Norton Antivirus

The installation is performed in the Windows XP embedded operating system. The operating system can only be accessed if an external keyboard and/or a mouse is connected. Operation by mouse only without the external keyboard is possible if the on-screen keyboard is used. To ensure recognition of the external devices, the instrument has to be switched off prior to connecting them.

1. Switch off instrument.
2. Connect an external keyboard and/or a mouse to the USB interface.
3. Switch on instrument.
4. Open the start menu (either by pressing the **Windows** key (on the keyboard next to the **Ctrl** key) or by moving the mouse to the bottom of the display and subsequent clicking on **Start**).



5. Click on **Control Panel**.  
The control panel window is displayed.

**6. Select System.**

The System properties window opens.

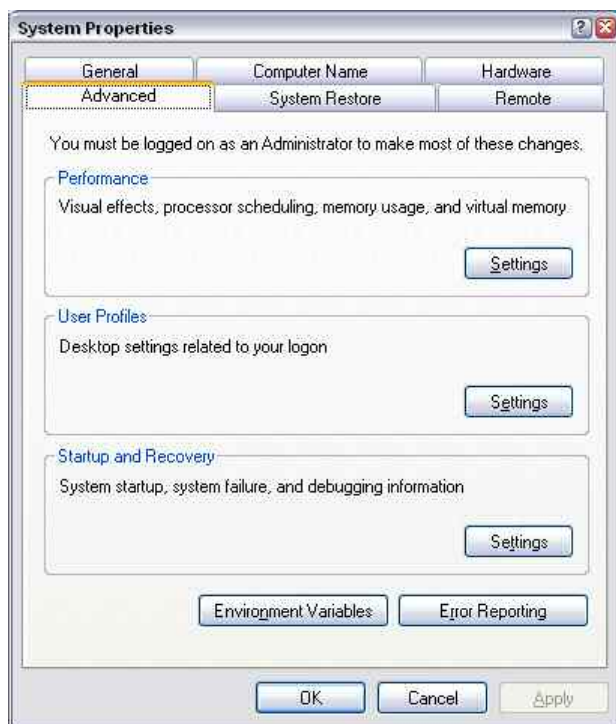
**7. Select the Advanced and click Performance Settings.**

The performance options window is displayed.

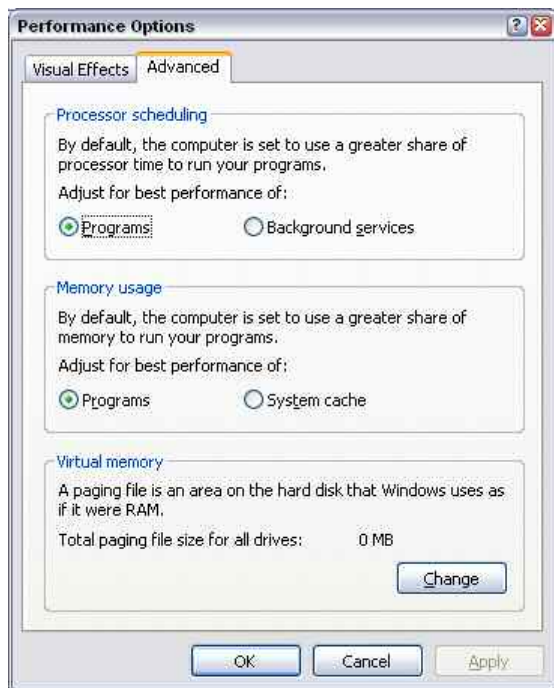
**8. Click on the Change button.**



9. Activate:
  - a) Drive D: [DATA]
  - b) System managed size

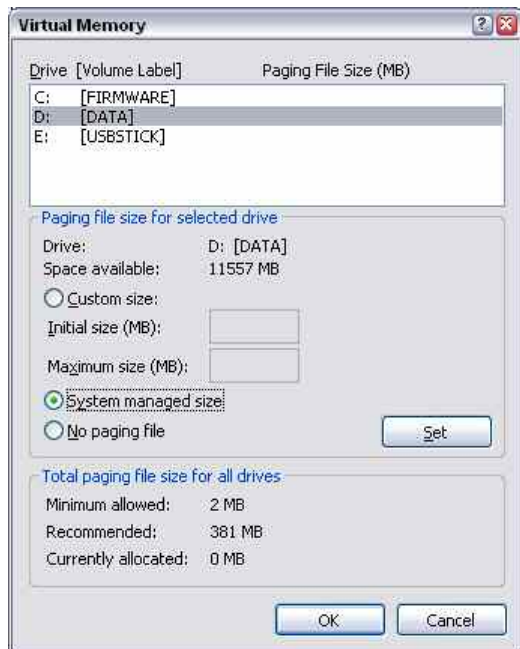

10. Click the **Set** button
11. Click the **Close** button, the dialog closes  
Now program Norton Antivirus can be installed



## Contents - Chapter 2 "Getting Started"

<b>2</b>	<b>Getting Started .....</b>	<b>2.1</b>
	Introduction - Getting Started .....	2.1
	Baseband Section of R&S SMJ.....	2.3
	RF Section of R&S SMJ .....	2.3
	Description of Individual Diagram Blocks .....	2.4
	Available Blocks .....	2.4
	Blocks of the Baseband Section.....	2.4
	Blocks of the RF Section .....	2.6
	Example of Setup .....	2.8



# 2 Getting Started

## Introduction - Getting Started

The main field of application of the R&S SMJ is the generation of digitally modulated signals. The R&S SMJ uses I/Q (vector) modulation. Digital data streams are converted to an I/Q baseband signal. The baseband signal is then D/A-converted and modulated onto the desired RF carrier frequency with the aid of an I/Q modulator.

The R&S SMJ provides an entirely digital baseband section for generating I/Q signals and an RF section with I/Q modulator.

The architecture of the R&S SMJ and the signal flow are shown in a block diagram on the R&S SMJ user interface. In the diagram, signal processing is performed from left to right (left: baseband signal generation, extreme right: RF output). The block diagram in the figure below shows a fully equipped R&S SMJ.

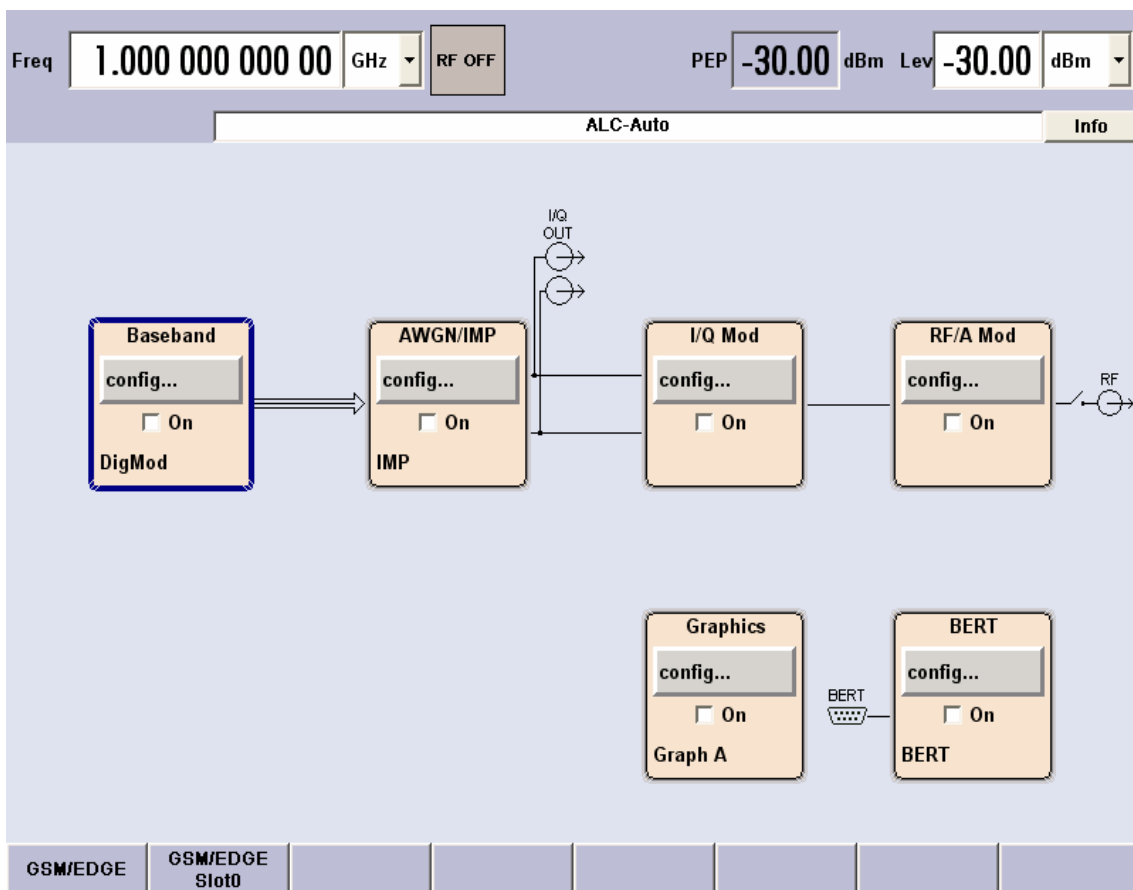

Fig. 2-1 Block diagram of a fully equipped R&S SMJ

In the R&S SMJ, a digitally modulated signal can be generated in several ways:

1. The I/Q signal is generated internally in the R&S SMJ. In this case the instrument must be equipped with a baseband generator (option R&S SMJ-B10) and a baseband main module (option R&S SMJ-B13).

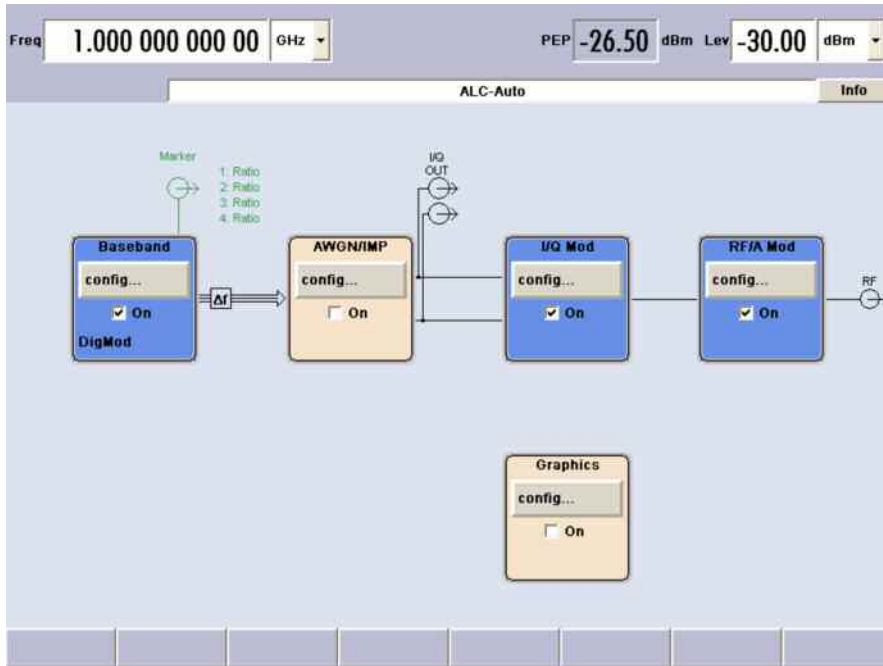

Fig. 2-2 Operation of R&S SMJ I/Q modulator with I/Q signals from the internal baseband section

2. An external analog I/Q signal is directly applied to the I/Q modulator of the R&S SMJ (Analog Wideband I/Q operation). In this mode, the entire bandwidth of the I/Q modulator can be utilized. The various capabilities of the baseband section (AWGN, addition of signals, etc) are disabled, however.

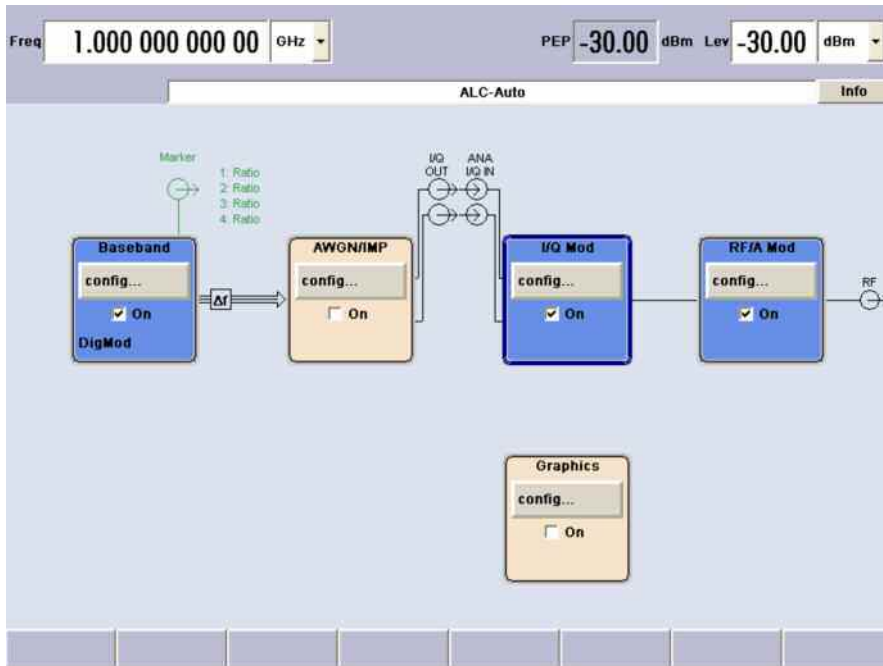

Fig. 2-3 Operation of R&S SMJ I/Q modulator with external analog I/Q signals directly applied to the I/Q modulator

## Baseband Section of R&S SMJ

The baseband section of the R&S SMJ is fully digital and contains the hardware for generating and processing I/Q signals.

**Baseband generator (option R&S SMJ-B10):** The generator produces baseband signals. It contains modules for real time signal generation and an arbitrary waveform generator (ARB). Option R&S SMJ-B10 contains real time Custom Digital Modulation and ARB. Software options providing various digital standards are offered in addition. Option R&S SMJ-K40, for instance, generates signals to GSM/EDGE standard, option R&S SMJ-K42 signals to 3GPP FDD standard. For more detailed information on available options, refer to the R&S SMJ data sheet and the R&S SMJ Configuration guide (available at R&S SMJ homepage on the internet).

**Baseband main module (option R&S SMJ-B13):** This module is at the end of the baseband path and converts the digital signal to an analog I/Q signal. The analog I/Q signal is fed to the I/Q modulator of the corresponding RF path. The baseband main module also routes signals to the analog I/Q outputs. This module is absolutely required for coupling out the baseband signal from the baseband section. The baseband main module also offers digital I/Q impairment functions. The I/Q signal can be deliberately corrupted, e.g. for testing the receiver quality.

**Additional White Gaussian Noise (option R&S SMJ-K62):** Additive white noise, which may be required for instance for measurements on mobile radio base stations, can be produced with the AWGN software option (R&S SMJ-K62).

## RF Section of R&S SMJ

An RF path is configured by installing a frequency option that comprises all required modules including synthesizer, output section with I/Q modulator and attenuator. One of the following options can be installed:

R&S SMJ-B103	100 kHz to 3 GHz
R&S SMJ-B106	100 kHz to 6 GHz

---

**Note:**

*One of these options must be installed.*

---

For more detailed information on options, refer to the R&S SMJ data sheet and the R&S SMJ Configuration Guide (available on the R&S SMJ Homepage on the Internet; <http://www.smj100a.rohde-schwarz.com>).

## Description of Individual Diagram Blocks

### Available Blocks

Block	Function of block	Status display in the block	Effect of <b>TOGGLE ON/OFF</b> key
<b>Baseband</b>	Baseband source is configured and activated	Selected modulation	Switches the selected modulation (digital standard, digital modulation or ARB) on or off.
<b>AWGN/IMP</b>	Additive white Gaussian noise production and digital impairments are activated	Active functions of block	Switches the active functions of the block on or off. The functions (AWGN, impairments or both) are activated in the respective menus.
<b>Graphics</b>	Graphical display is selected and activated	Status of graphical display	Opens or closes the graphics window.
<b>I/Q Mod</b>	I/Q modulator is configured, I/Q impairments are selected and activated	Analog I/Q impairments, I/Q swap	Switches the I/Q modulator on or off.
<b>RF/A Mod</b>	RF signal, analog modulations, list mode and sweeps are configured and activated	Active analog modulation modes	Switches the RF signal on or off.
<b>BERT</b>	Bit and block error rate measurement are configured and activated	Selected measurement(s)	Switches the active function(s) of the block on or off. The functions (BERT and BLER) are activated in the respective menus.

### Blocks of the Baseband Section

#### Baseband block



In this block, the (first) baseband source is configured and activated. The block is displayed only if a baseband generator (option R&S SMJ-B10, Universal Coder and ARB) is available in the instrument. Depending on the installed software options, various digital standards, user-configured digital real time modulation or the built-in waveform generator (ARB) can be selected. The selected modulation is displayed in the block. The **TOGGLE ON/OFF** key switches the selected system on or off.

**AWGN/IMP block**

This block is displayed only if a baseband main module is installed. In this block (digital) I/Q impairments can be set. With the aid of the software for AWGN generation (option R&S SMJ-K62), an (additive) noise signal can be produced.

AWGN and impairments can be activated independently of each other in the appropriate menus. The settings are displayed in the block. The entire block can be activated or deactivated with the **TOGGLE ON/OFF** key. If the block is deactivated, the signal passes through the block unchanged. In addition, the differential I/Q output is configured in this block (option R&S SMJ-B16).

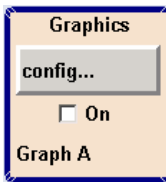
**Graphics block**

With this block, the baseband signal can be graphically displayed in real time. The block is displayed only if a baseband main module is installed.

**BERT block**

In this block an integrated bit and block error rate tester can be set. The bit error tester makes it possible to evaluate a signal demodulated and decoded by a DUT by measuring the bit error rate. The data used to drive the DUT can be generated by the R&S SMJ or an user-defined external source. In addition, the block error rate measurement can be used to verify CRC checksums.

## Blocks of the RF Section

### I/Q Mod block



The I/Q modulator is configured in this block. Also the Analog Wideband I/Q mode can be selected here, which allows external I/Q signals to be directly applied to the I/Q modulator, i.e. not via the baseband section. If no baseband modules are installed, I/Q modulation is possible only in the Analog Wideband I/Q mode. I and Q components can be swapped (I/Q Swap). (Analog) I/Q impairments can be set in addition. Unlike the impairments in the AWGN/IMP block, impairments in the I/Q Mod block also affect the externally applied signals in the Analog Wideband I/Q mode.

The status display in the block shows whether I/Q impairments and/or I/Q swap is active. I/Q modulation is switched on or off with the `TOGGLE ON/OFF` key.

---

#### Note:

*An I/Q modulator provided in the R&S SMJ is automatically activated when a connected baseband source is switched on. The I/Q modulator can also be separately switched on and off (select the I/Q Mod block and press the `TOGGLE ON/OFF` key). This permits the following configuration to be obtained with a R&S SMJ.*

*The baseband source generates an I/Q signal that is output via the analog I/Q output. At the same time, the RF section generates an unmodulated carrier.*

---

### RF/A Mod block



In this block, the RF parameters and the analog modulation modes are set.

The active analog modulation modes are displayed in the block. The `TOGGLE ON/OFF` key switches the RF signal on and off. When the signal is switched off, the switch before the RF output symbol is open.

RF settings include:

- ◆ Frequency and reference frequency
- ◆ Attenuator settings; if required.
- ◆ Frequency and level sweep
- ◆ List Mode settings. In this mode, extremely fast frequency and level settings can be made.

---

#### Note:

*Numeric values for frequency and level are entered best and quickest with the aid of the `FREQ` and `LEVEL` keys.*

---



Available analog modulation modes:

- ◆ Amplitude modulation
- ◆ Broadband amplitude modulation
- ◆ Frequency modulation (option R&S SMJ-B20)
- ◆ Phase modulation (option R&S SMJ-B20)
- ◆ Pulse modulation

---

**Note:**

*For modulation modes that can be simultaneously used, refer to the R&S SMJ data sheet.*

---

## Example of Setup

A central element of the R&S SMJ display is the block diagram that illustrates the signal flow. Each block represents an important section of signal generation. Thus the user always knows the position at which a parameter has an effect in the signal flow. The main settings of a block are indicated in the block. The interconnection of employed inputs and outputs is also shown. The user is thus always informed about the connection of inputs and outputs in the signal flow and where they can be configured.

A window is opened for each menu where parameters can be set. When the window is opened, an entry is made in the Winbar below the display. All open menus are of equal priority (not modal) and can be accessed any time.

The R&S SMJ can be entirely operated from the front panel. Peripherals such as mouse or keyboard can be connected but are not essential.

With the aid of the rotary knob, the user can navigate in the block diagram and the dialogs. The cursor is moved line by line through the block diagram or dialog. Turning the button clockwise advances the cursor. The selected block can be activated or deactivated with the **ON/OFF TOGGLE** key. Active blocks are highlighted by a colored background.

In the example, a simple QPSK-modulated signal is configured and displayed. Proceed as described below:

1. Activate default (preset) state.
2. Select and activate digital modulation.
3. Set frequency and level and activate RF signal.
4. Select graphics display of I/Q signal.

### Step 1: Activate default (preset) state



Set a defined instrument state by pressing the **PRESET** key.

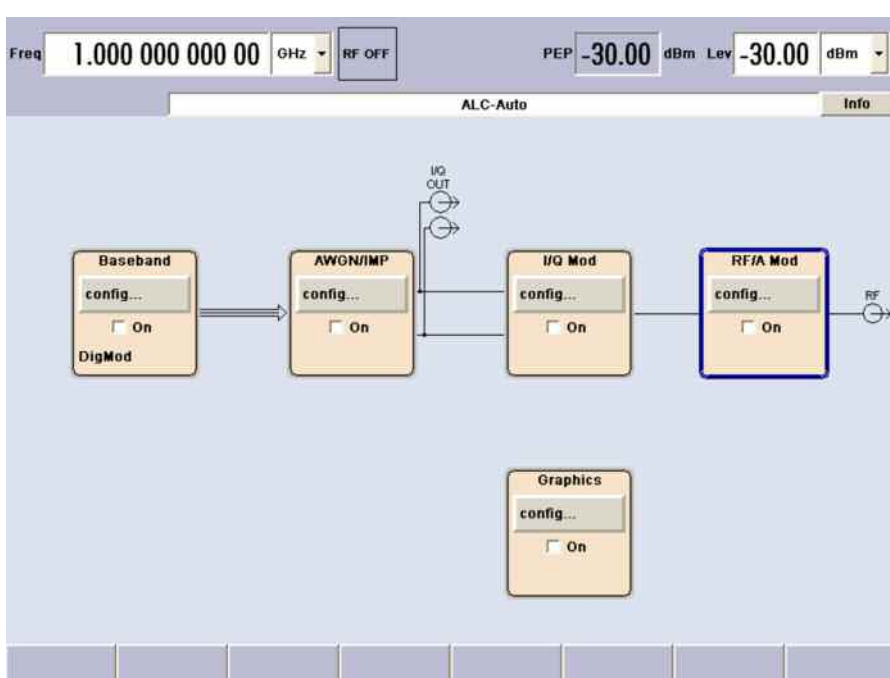

Step 2: Select and activate digital modulation



Select the Baseband block by turning the rotary knob.

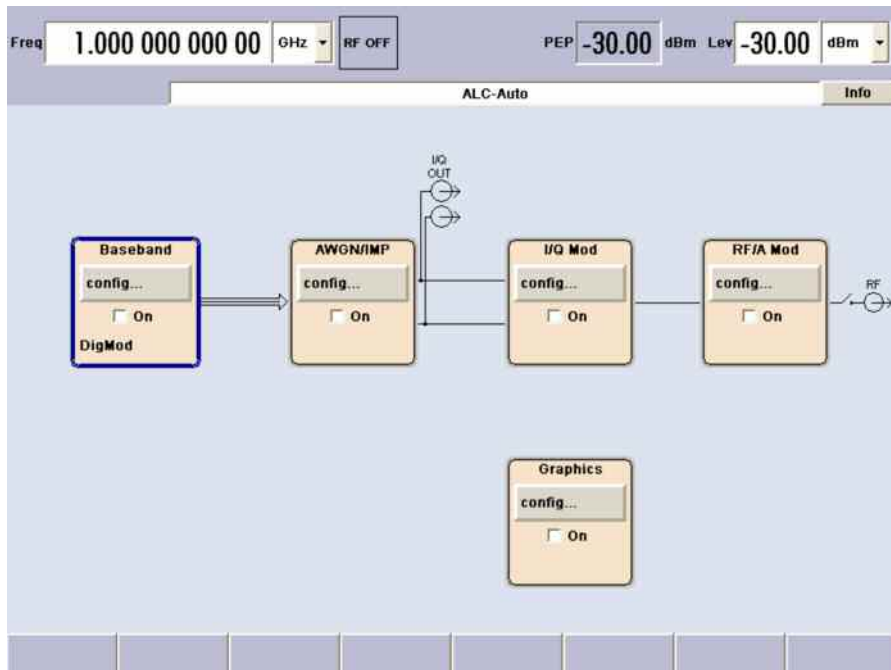

Press the rotary knob to open the menu where the digital modulation can be selected (different modulation modes are available depending on the options installed).

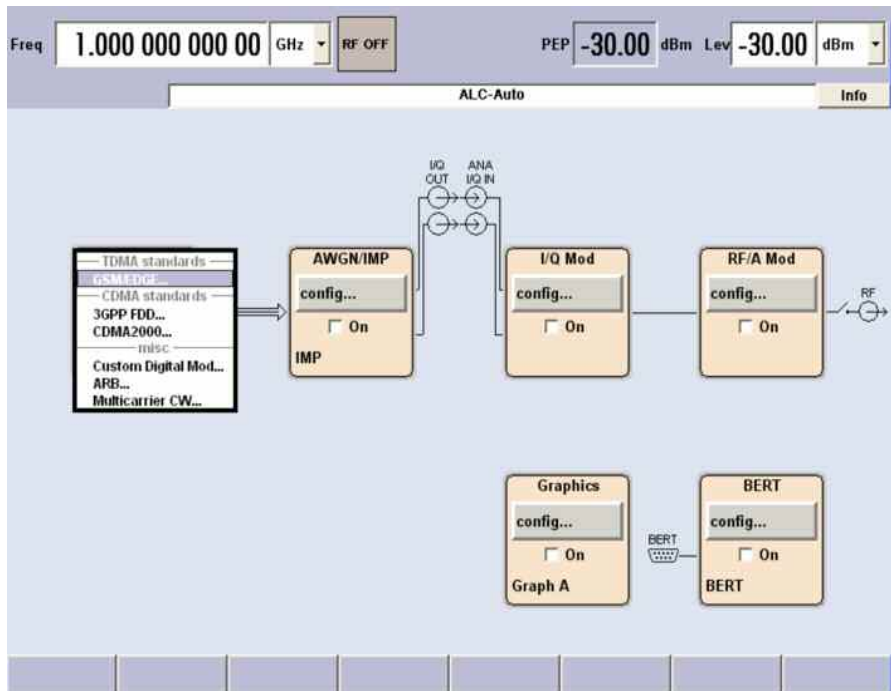



Highlight **Custom Digital Mod...** by turning the rotary knob.

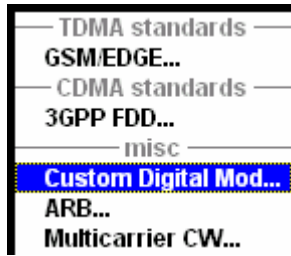

Press the rotary knob to open the **Custom Dig. Mod.** menu.

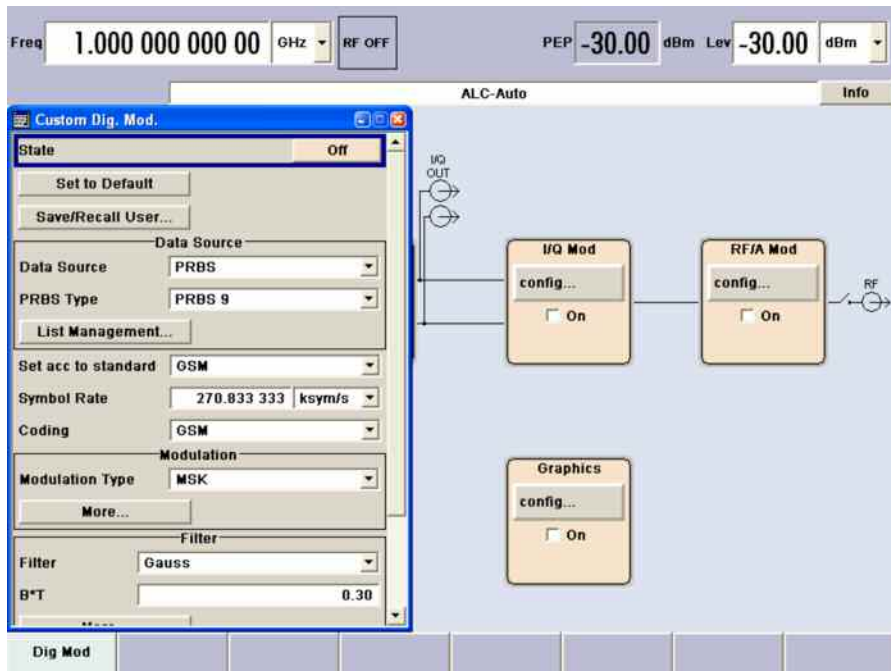

Select the **Symbol Rate** parameter by turning the rotary knob, and then enter the desired symbol rate with the aid of the numeric keypad and the unit keys.

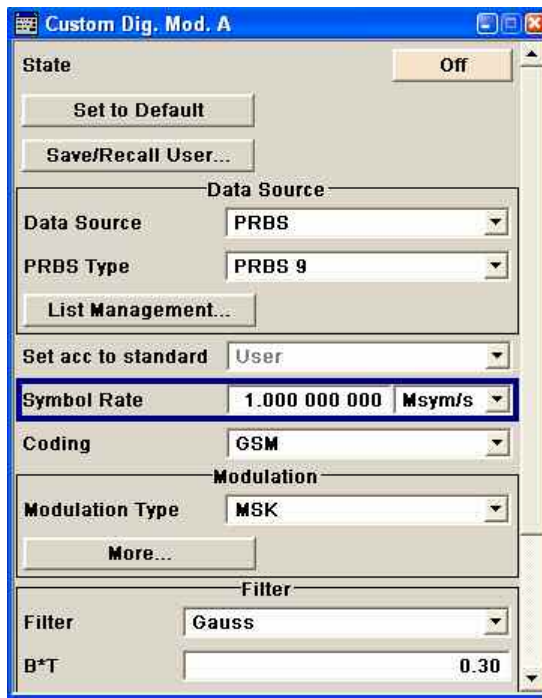



Select the **Coding** parameter by turning the rotary knob. Press the button to open the selection list. Select **Off** by turning the rotary knob and press it to activate the selected item.

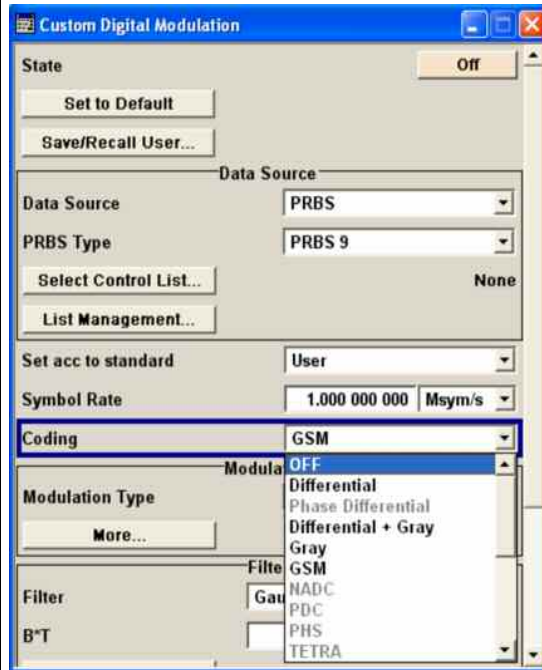

Set **Modulation Type QPSK** and **Filter Root Cosine** with **Roll Off Factor 0.3** in the same way using the rotary knob.

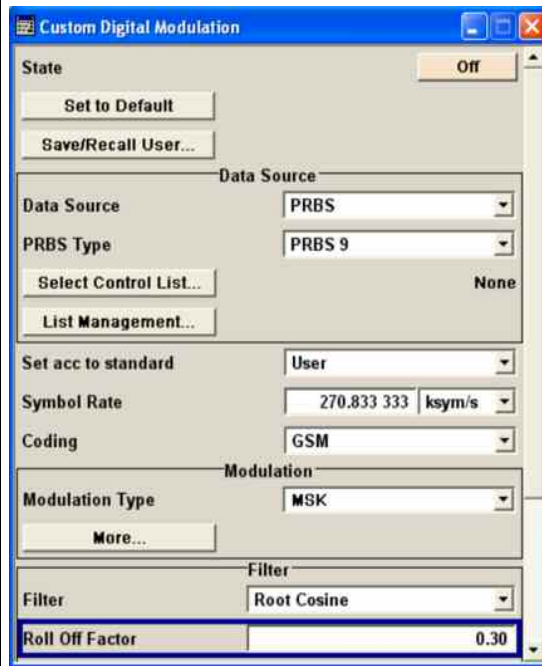



Finally, switch on digital modulation by selecting **State On**.

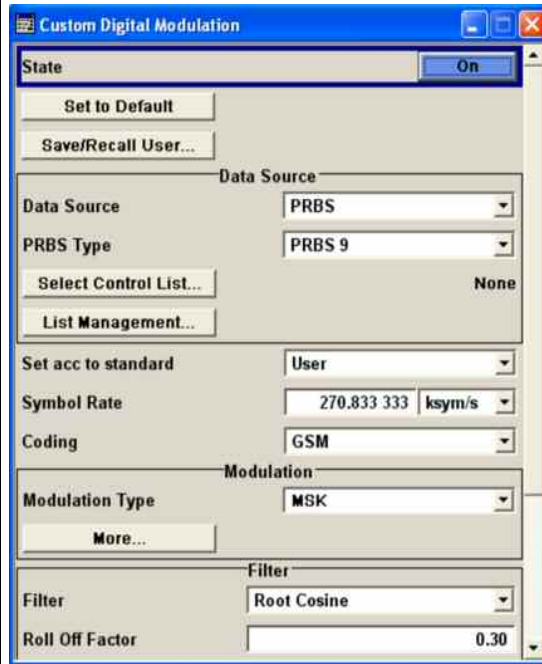

Press the **DIAGRAM** key to display the complete block diagram.

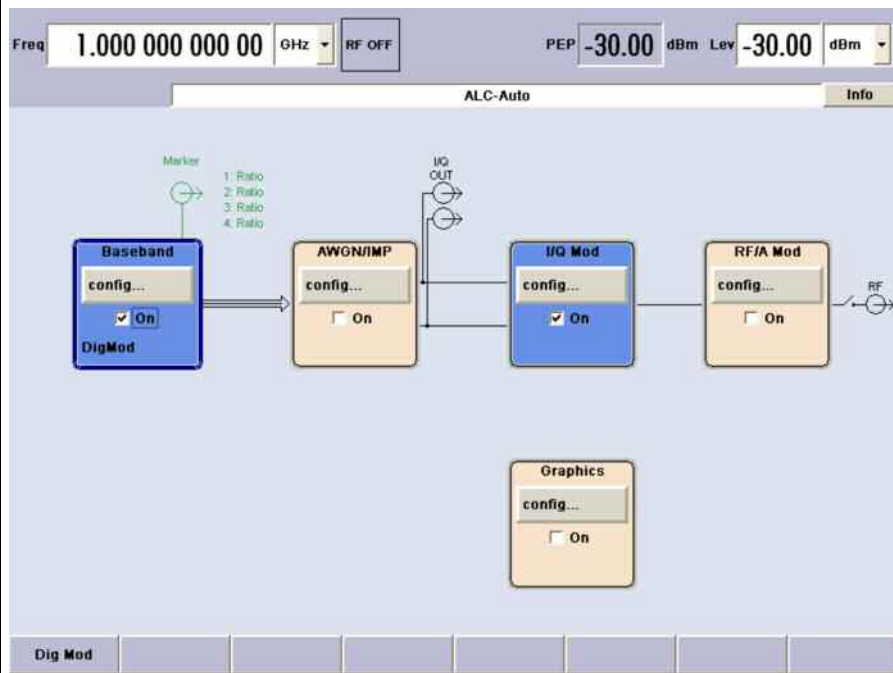

To indicate the active state, the **Baseband** block is displayed in blue. The **I/Q Mod** block is automatically activated. The **RF/A Mod** is not yet active, which means that no RF signal is output. The entry in the Winbar indicates that the Custom Dig. Mod. menu is still open in the background.



The menu can be displayed in the foreground by clicking the softkey below the button in the Windows list.



Press the **HIDE** key to minimize the menu again.

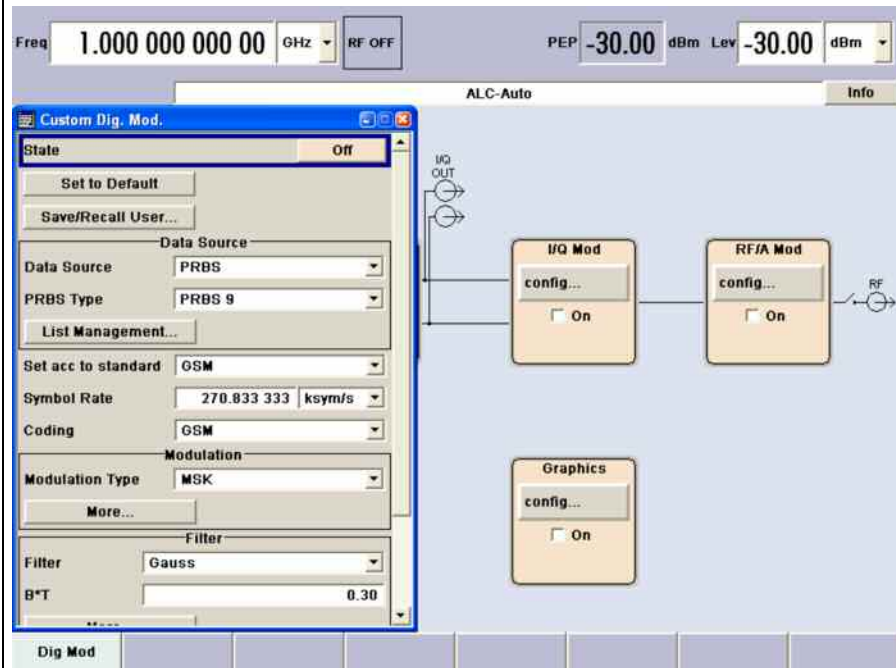

**Step 3: Set frequency and level and activate RF signal**



Press the **FREQ** key to activate the editing mode for frequency entry. The frequency entry field in the header section of the display is highlighted.

Enter the frequency using the numeric keypad and terminate the entry by pressing a unit key.

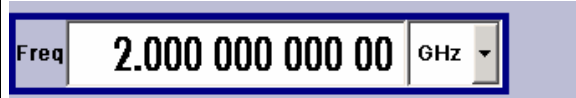



Enter the level in the same way after pressing the **LEVEL** key.



Press the **DIAGRAM** key to display the complete block diagram.



Select the RF/A Mod block by turning the rotary knob and activate it by pressing the **TOGGLE ON/OFF** key.

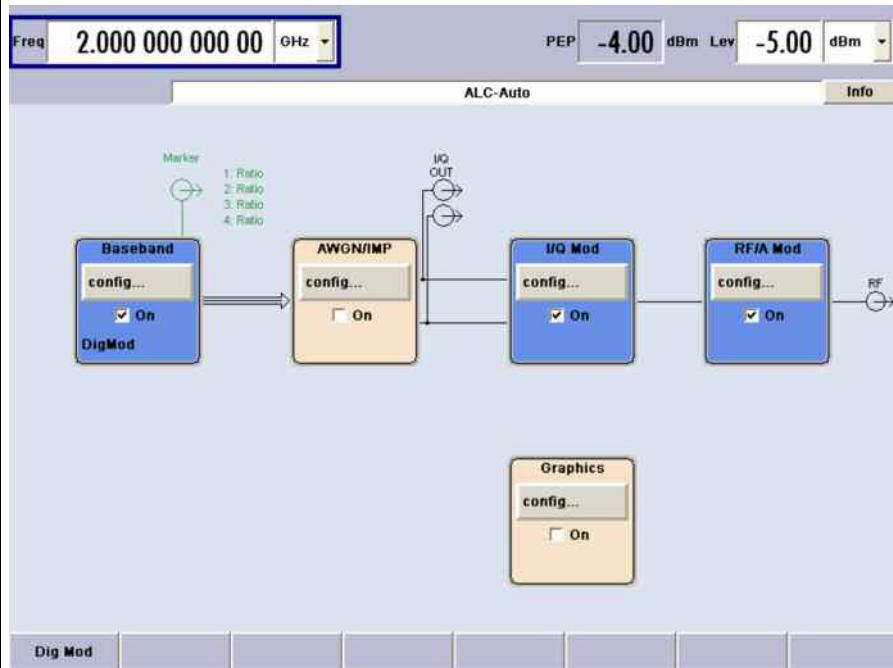



The QPSK modulation signal is now present at the RF output.



Step 4: Select graphics display of I/Q signal

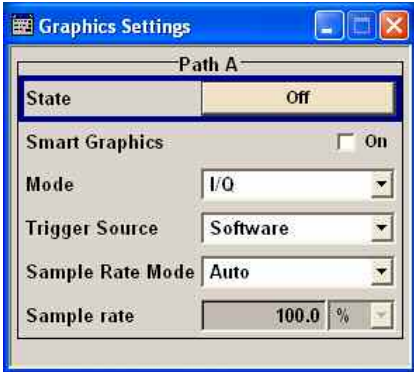

Select the Graphics block and open the respective menu by turning the rotary knob.

Activate display of the I/Q diagram by selecting **State On** with the rotary knob.

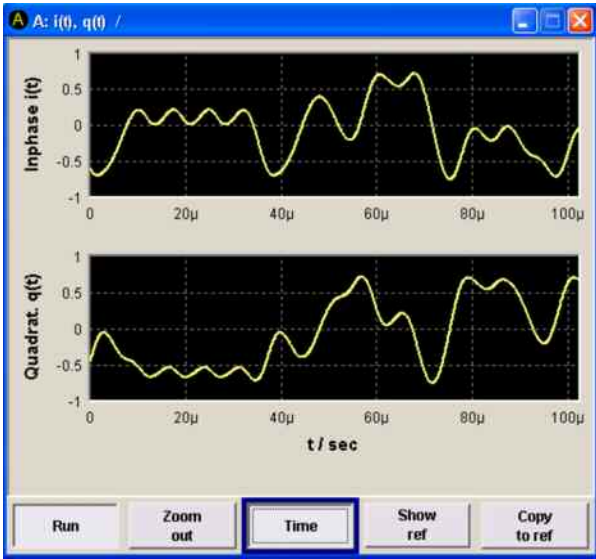

The R&S SMJ comprises a comprehensive **info** and **help system**. Context-sensitive help can be called any time with the **[HELP]** key. The help system indicates the currently selected parameter and offers additional services such as cross references, index and contents. The content of the help system corresponds to the operating manual of the R&S SMJ.

Warning and conflict messages caused by incorrect operation as well as further information are displayed in the **Info line**. A complete list of existing conflicts is displayed when the **[INFO]** key is pressed. Additional information on entries can be requested from the help system. The history function permits display of all messages.

**Assistants** simplify the completion of tables. After data entry in the assistant, the table is modified only after the **Accept** button has been pressed. Pressing the **Accept** button also stores the assistant data.

Detailed operating instructions and an overview of menus follow in chapter 3, "[Manual Operation](#)", on page 3.1.

Menus and instrument functions are described in detail in chapter 4, "Instrument Functions".



## Contents - Chapter 3 "Manual Operation"

<b>3</b>	<b>Manual Operation .....</b>	<b>3.1</b>
	Introduction - Manual Operation .....	3.1
	Operating Concept .....	3.1
	Display .....	3.7
	Frequency and Level Setting - Display.....	3.7
	Status Information and Messages - Display.....	3.8
	Info Window - Display.....	3.9
	Block Diagram - Display .....	3.10
	Winbar and Softkeys - Display .....	3.12
	Menu Structure - Display .....	3.13
	Graphical Display of Output Signal Characteristics .....	3.15
	Setting Parameters.....	3.16
	Calling a Menu - Setting Parameters .....	3.16
	Selecting a Control Element - Setting Parameters.....	3.17
	Switching Parameters On/Off - Setting Parameters.....	3.18
	Selecting and Exiting a Menu Area - Setting Parameters.....	3.18
	Entering a Value - Setting Parameters.....	3.20
	Selecting a Unit - Setting Parameters .....	3.22
	Selecting a Value from a List - Setting Parameters .....	3.23
	Terminating Entries - Setting Parameters .....	3.24
	Restoring the Previous Value - Setting Parameters.....	3.25
	Menu Operation .....	3.26
	Editors.....	3.27
	List Editor.....	3.27
	Data Editor.....	3.29
	Control and Marker List Editor.....	3.31
	Help system .....	3.35
	File Management.....	3.37
	File Select Menu.....	3.38
	File Manager.....	3.40
	Manual Remote Control.....	3.43
	Legend of Front-Panel Controls .....	3.44
	Front Panel Key Emulation.....	3.45
	On-screen Keyboard .....	3.46



## 3 Manual Operation

### Introduction - Manual Operation

The Vector Signal Generator R&S SMJ can be operated intuitively either via the interactive block diagram or via a menu tree. All menus are in the form of windows that can be operated in the same way. Rotary knob, keys and softkeys, or alternatively a mouse, allow direct and therefore convenient access to entries and settings. The clear-cut display shows the current signal generator state. Graphs, spectra, vector diagrams, etc, can be called for a visual check of the output signal. Numerous help functions support the user in signal configuration.

The following chapter describes manual operation of the signal generator. This includes a description of screenshots, operation of menus and the block diagram and the setting of parameters. An overview of menus and functions can be found at the end of this chapter.

### Operating Concept

The operating concept of the R&S SMJ enables the user to make settings as intuitively as possible and at the same time gives a permanent overview of characteristics of the generated signal and of the current instrument state. Numerous on-line help functions support user settings.

#### The block diagram is the core of the operating concept.

A large graphics display showing the current configuration and the signal flow in the form of a block diagram is the core of the operating concept of the Vector Signal Generator R&S SMJ. The block diagram gives an overview of signal configuration, and the graphical elements can be accessed for operation. The desired element is selected by means of the rotary knob and the associated setting function is called by clicking this button. Required menus and graphs are displayed on the block diagram which is displayed again in the foreground whenever the **DIAGRAM** key is pressed.

#### Permanent display of frequency and level of the RF output signal

The main characteristics of the RF signal, frequency and level, are permanently displayed in the header section of the screen and can be directly set in the display fields after the **FREQ** or **LEVEL** key is pressed. Status messages for the output signal are displayed in addition to frequency and level.



**Operation via the graphics interface**

Menus are assigned to the specific function blocks in the block diagram. The function blocks represent elements of signal generation, e.g. the baseband block which contains all menus required for baseband signal configuration. In this block all digital standards and the digital modulation can be selected. Function blocks displayed with a blue frame can be directly switched on and off by means of the **TOGGLE ON/OFF** key. In the example, digital modulation can be activated in this way. The menus of the highlighted function blocks can be be called by clicking the rotary knob or by pressing the **ENTER** key.

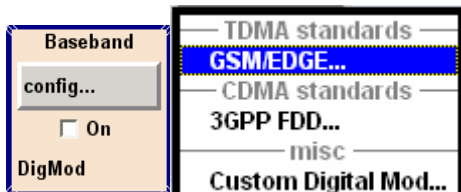

The signal flow between the function blocks and the employed inputs and outputs are also shown.

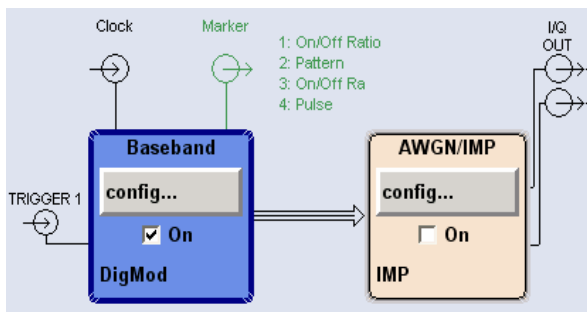

The menu tree can be opened and closed with the **MENU** key. The menu tree is organized in the same way as the directories under Windows. The function blocks correspond to the first directory level, the menus to subdirectories.

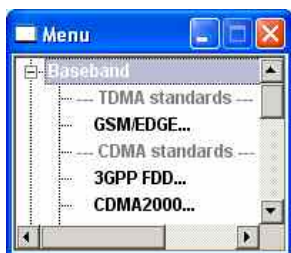

**Operation corresponds to the Windows concept**

To offer the user a familiar environment, operation is very similar to operation of Windows user interfaces. All menus and tables are made up of known elements, e.g. selection lists,

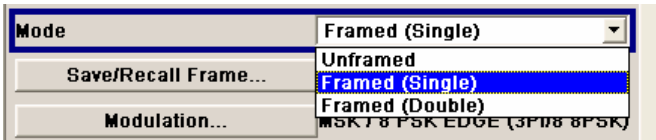

check boxes,



or entry fields.



A blue frame indicates that the selected item is active. In the highlighted element, entries can be made.

**Most of the settings can be easily made with the rotary knob**

Operation is possible via front-panel keys, an external keyboard and the mouse. Most of the settings can be made with the rotary knob:

- ◆ Turning the rotary knob shifts the entry focus to the desired element.
- ◆ Clicking the rotary knob activates the selected entry field.
  - Depending on the parameter, the submenu is now called, the numeric value varied, the list entry selected or the check box activated or deactivated.
- ◆ If a value is entered, the entry is stored by another click on the rotary knob and the editing mode is exited.

**Clear settings with the aid of independent submenus**

A separate menu is opened for each menu and submenu. The menus can be operated independently of each other, i.e. none of the menus requires that settings in other menus be completed before it can be closed. This ensures flexible operation at all times.

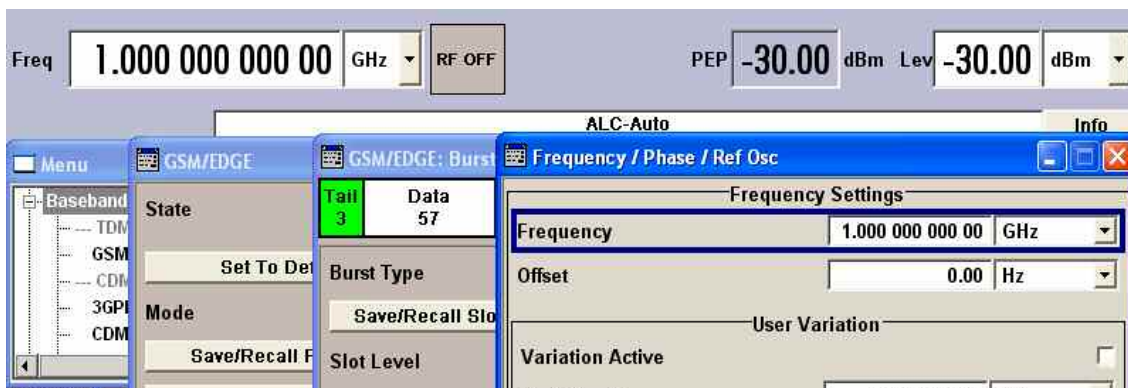

**The Winbar gives an overview of menus and simplifies their access.**

The menus are displayed on top of the block diagram but they can be "hidden", i.e. displayed in the form of a button in the Winbar at the lower end of the screen ( **HIDE** key). They can be displayed again in full size by a keystroke ( **REARR** key). This makes room on the screen for other displays that may be required but the setting menus can thus be accessed any time.



**The keys are assigned simple functions**

Most keys on the front panel of the R&S SMJ directly perform a simple function. Since a great number of settings can thus be made by a keystroke, operation is easy. For instance, the **CLOSE** key closes the active menu; with the **RF ON/OFF** key the RF output signal can be switched on or off.

An exception are keys that call a menu such as the **MENU** key which opens the complete menu tree of the R&S SMJ, the **SETUP** key which opens the menus for general instrument settings or the **FILE** key which opens the menu for file management.

**Help functions support the user**

Numerous help functions support the user in signal configuration.

The valid setting range can be displayed for each numeric parameter. This requires a short wait after activation of the entry field. The range is then displayed automatically after a few seconds. If the entered value is outside the permissible range, the next permissible value is automatically set and a message is output (see below).

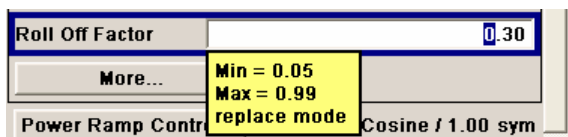

Context-sensitive help for each parameter can be called with the **HELP** or **F1** key:

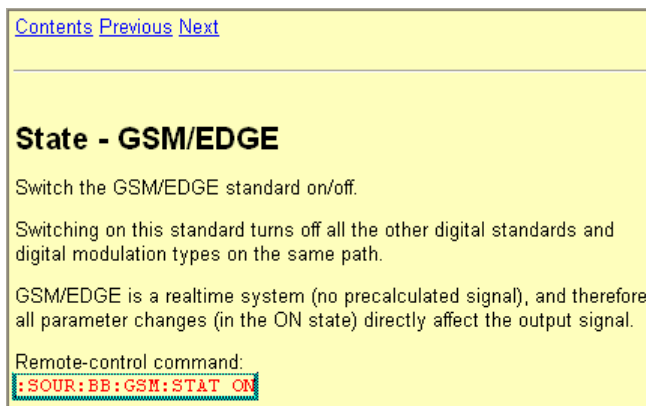



Each help page is part of a comprehensive online help function which can be called by means of an index, a content tree or the **Previous** / **Next** buttons.

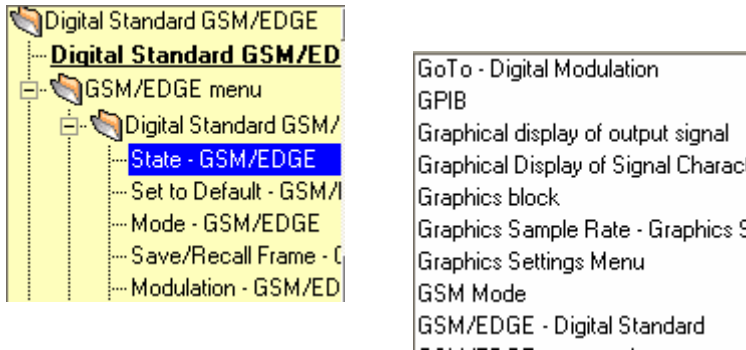

**Messages indicate the current instrument state**

A great variety of different messages such as status messages, error messages, warnings or information are displayed in the header field of the screen. With the aid of the **INFO** key, help pages can be called for most of the messages. They provide background information on the message and indicate operating steps that may be required. All messages are explained in the online help which can be called with the **HELP** key.

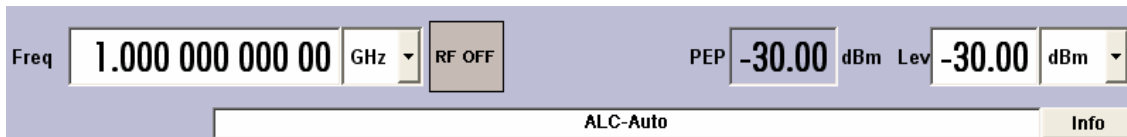

**Graphical display of data structure**

The structure of the baseband signal is graphically displayed in the respective menus; the individual signal elements can be graphically selected for processing.

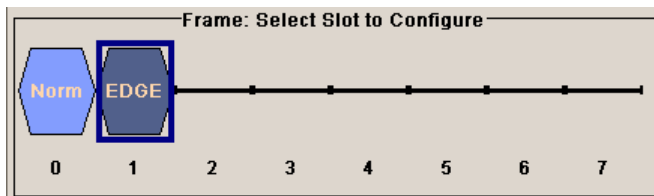

**Definition of control signals with the aid of a graphics editor**

Control signals are also graphically configured.



**Graphical display of output signal in a diagram**

The output signal can be graphically displayed in a number of diagrams. This allows a fast check of signal characteristics. Zoom functions and the insertion of a reference trace permit in-depth evaluation without an external analyzer being required.

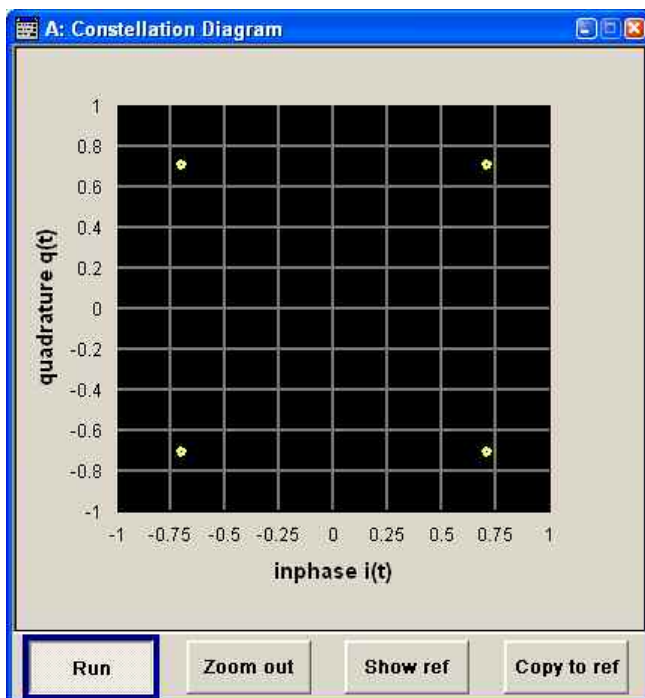

## Display

The display shows the current signal generator state and offers graphical elements for direct operation. It is divided into three sections:

- ◆ The frequency and level display with info line indicates the main output signal parameters and reports the current state with status, error and warning messages.
- ◆ The block diagram shows the instrument configuration, the signal characteristic as well as the inputs and outputs used and permits interactive operation via graphics elements. Active menus and graphs are displayed on top of the block diagram.
- ◆ Winbar with labelled softkeys for menu display.

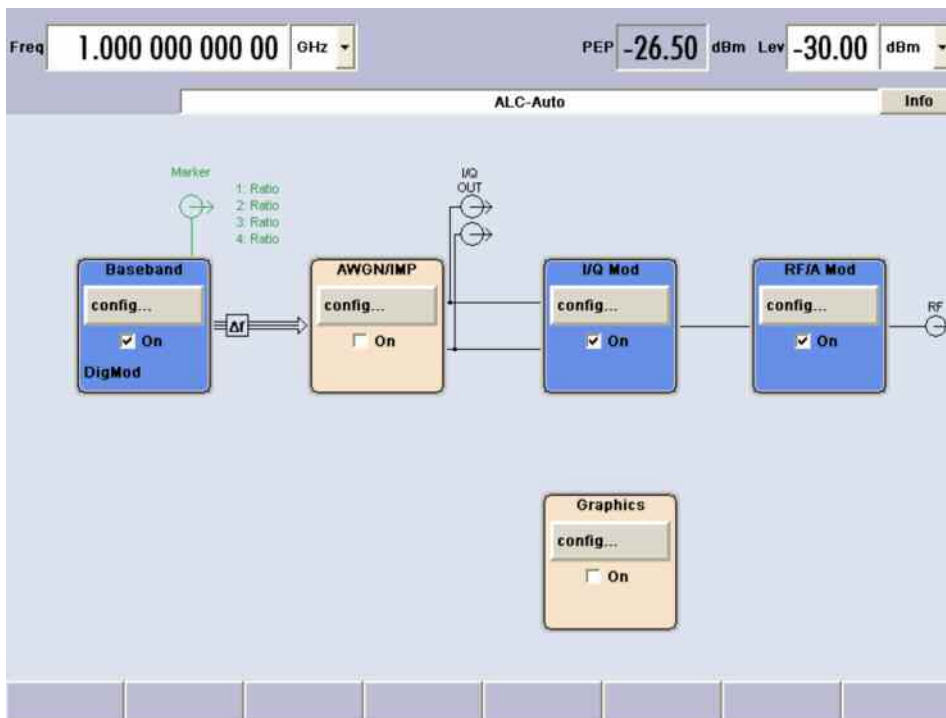

### Frequency and Level Setting - Display

Frequency/level settings and a few status messages (see below) are displayed in the header field of the screen. The display may vary depending on the instrument's operating mode:

- ◆ In the sweep mode, the current frequency or level of the output signal is displayed. The status message **ListMode** is displayed in the info line.
- ◆ In the list mode, neither the current frequency nor level is displayed, the indication is dimmed.
- ◆ If user correction is active, the status message **UCorr** is displayed in the info line.
- ◆ In the case of digital modulation, **Freq** indicates the frequency, **PEP** the peak envelope power and **Level** the average level.

It should be noted that the signal at the RF output may differ from the indicated value by a set offset (frequency or level) (see chapter 4, sections "RF Frequency and Phase - Frequency - Phase" and "RF Level - Level - EMF").

## Status Information and Messages - Display

The status information and messages are displayed in the header section of the screen. The messages differ with respect to their importance (errors, warnings, info) and the time of their appearance (brief and permanent messages). They require different treatment by the user. Further information on all messages can be called in the info window (see section "Info Window - Display", page 3.9).

Chapter 9, "Error Messages" includes an overview of all status information and messages as well as instructions for error elimination.

### Status Information

The status information gives the user an overview of the main operating states and settings of the R&S SMJ. The states are indicated for information only and do not necessitate any action by the user. Status information is displayed between the frequency and level fields, at the left of the info line or in the info line itself.

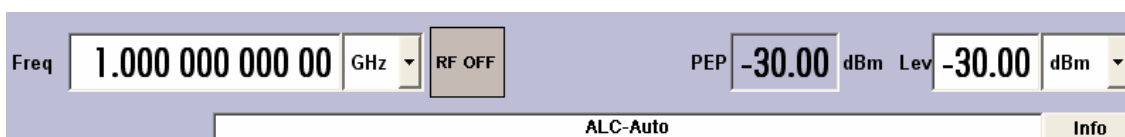

### Messages

Messages indicate errors in the instrument. They are displayed in the info line in different colors depending on their importance and display duration. Errors (e.g. no calibration data) are displayed in red, information (e.g. file not found) and warnings in black. Warnings indicate less significant errors (e.g. the instrument operates outside specified data).

#### Volatile messages

Volatile messages report automatic settings in the instrument (e.g. switching off of incompatible types of modulation) or on illegal entries that are not accepted by the instrument (e.g. range violations). They are displayed in the info line on a yellow background. They are displayed on top of status information or permanent messages.

Volatile messages do not normally demand user actions and disappear automatically after a brief period of time. They are stored in the history, however.

Remote-control command:  
`SYST:ERR?` or `SYST:ERR:ALL?`

#### Permanent messages

Permanent messages are displayed if an error occurs that impairs further instrument operation, e.g. a hardware fault. The error signaled by a permanent message must be eliminated before correct instrument operation can be ensured.

The message is displayed until the error is eliminated. It covers the status display in the info line. After error elimination, the message automatically disappears and is also recorded in the history.

Remote-control command:  
`SYST:SEERR?`

## Info Window - Display

A few operating states and the current message are displayed in the info line (see chapter 9 "Error Messages").

The info window with a list of current permanent messages and a detailed description of each message can be opened with the **INFO** key.

The upper section of the info window contains a list of all current permanent messages in the order of their occurrence, i.e. the most recent message is displayed first. In the lower section of the window, additional information on the highlighted message is displayed.

A history of all messages that have occurred since instrument switch-on can be called with the **History** softkey. The most recent message is displayed first.

The screenshot shows the Info Window interface. At the top, there is an 'Info line' with the text 'ALC-Auto' and an 'Info' button. Below this is a list of messages with columns for level, SCPI code, and text. The messages are: 'Err 463 Filename missing', 'Err 241 No current list', 'Err 463 Filename missing', and 'Info 0 SavRcl Manager Info: operation complete -Recall completed'. Below the list is a detailed description area showing '- No pending errors.' At the bottom, there are four softkey buttons: 'Delete', 'Delete all', 'Del. volatile', and 'History'.

The messages are color-coded according to their level. Device-specific messages are red, info and remote control error are black. The level is also indicated in the **Lev** column (Err, Sys or Info). Column **SCPI** indicates the SCPI error code.

With the aid of the softkey buttons, error messages can be cleared and a history of all messages called.

**Delete** Clears the highlighted message. This button is available only if the history of the messages is displayed.

Remote-control command:  
(see below)

**Delete all** Clears all messages. This button is available only if the history of the messages is displayed.

Remote-control command: n.a

**Sel. volatile**

Clears all volatile messages. This button is available only if the history of the messages is displayed.

Remote-control command:  
SYST:ERR:ALL?

(Each time a SYSTem:ERRor:ALL? query is sent, the error queue is returned and at the same time cleared).

**History**

Calls the list of all messages that have occurred since instrument switch-on. The most recent messages are displayed at the top of the list. When the button is pressed again, the list of current messages is displayed.

Remote-control command:  
SYST:ERR? or STAT:QUE?

(Each time a SYSTem:ERRor? or :STATus:QUEue? query is sent, the oldest entry in the error queue is returned and at the same time cleared in the list).

### Block Diagram - Display

The block diagram shows provided options, signal configuration and the currently selected signal flow of the generator with inputs and outputs used. Signal generation can be completely operated from the block diagram. The highlighted function block can be directly switched on and off with the **TOGGLE ON/OFF** key. Clicking the rotary knob (= Enter) opens the associated setting menu.

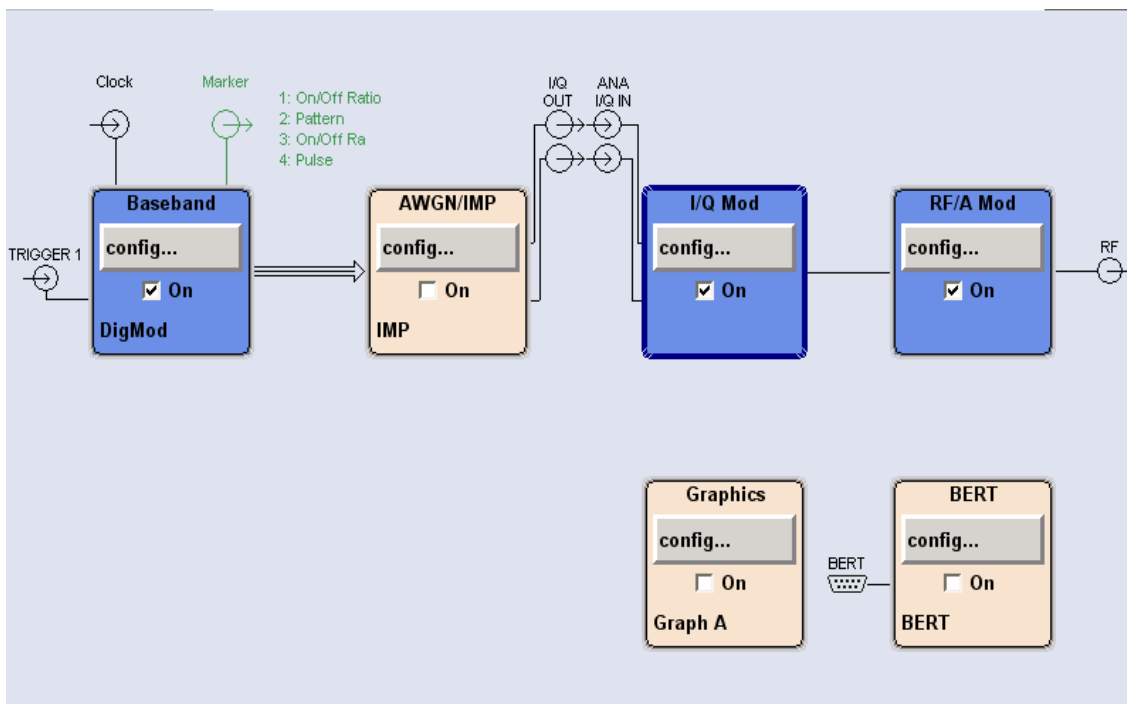

### Function Blocks in the Block Diagram

Each block represents a function of signal generation. The function is indicated in the headline of the block, e.g. **Baseband**. In this block, the digital modulation signal, the digital standards, arbitrary waveform generation and multicarrier CW are set, for instance.



In the check box  **On**, the respective function can be quickly activated/deactivated with the **TOGGLE ON/OFF** key. After activation, the block is displayed in blue.

Status information is displayed below the check box. It is different for the different blocks. In the baseband block, for instance, the selected modulation and associated additional information, e.g. the number of channels, are indicated.

Clicking the rotary knob (front panel) or the **config...** button (mouse) opens the associated setting menu. In all function blocks where the signal flow can be influenced, the top menu level for setting **signal routing** parameters is offered.



### Signal Flow and Input/Output Symbols in the Block Diagram

The input/output symbols in the block diagram show the currently used inputs and outputs of the signal generator. Unused inputs and outputs are not shown. The lines indicate the signal flow.

Symbols and labels refer to the corresponding inputs and outputs on the front and rear panel of the signal generator. The direction - input or output - is indicated by an arrow.

#### Example:

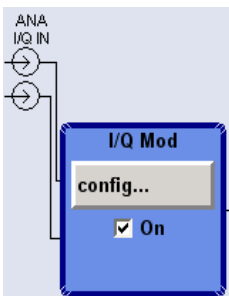

The symbols indicate the inputs for the analog I and Q signal on the instrument front panel.

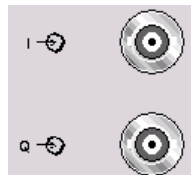

The marker characteristics are listed next to the marker symbol of the active markers.

Symbols and lines are displayed in different colors depending on their function.

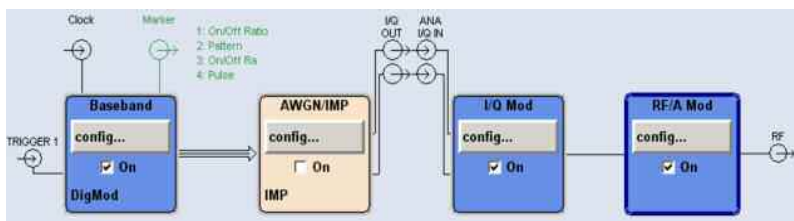

- ◆ The baseband signal is indicated by a three line arrow, the I- and Q-components of the signal by a single-line arrow.
- ◆ Black is used for the generated signal.
- ◆ Green is used for control signals.

The signal flow is configured in the individual menus. User interfaces are configured in the **Setup-Environment - Global Trigger/Clock/External Inputs - USER Marker /AUX I/O Settings** menu.

## Winbar and Softkeys - Display

The Winbar with eight buttons is displayed below the block diagram. Labelled buttons represent open menus, the label indicates the menu. If several menus are open, the button of the currently active menu is displayed in a lighter colour. The buttons also assign functions to the softkeys of the next lower level for front-panel operation. Up to eight menus may be open simultaneously. When the ninth menu is opened, the menu that was opened first is automatically closed.



Some menus, e.g. data and list editor menus, cover the Winbar and assign menu-specific functions to the front-panel softkeys by way of the menu buttons.

Any of the open menu can be activated either with the respective button in the Winbar or the front-panel softkey. In combination with the keys for menu operation (**CLOSE**, **HIDE** and **REARR**), convenient menu operation can be ensured.

Menu operation is described in section "[Menu Operation](#)", on page 3.26.



## Menu Structure - Display

The parameters are set in the menus. Menus are called either via the function blocks in the diagram or by means of the **MENU** key. The menus are displayed on top of the block diagram. If the menu buttons assign menu-specific functions to the softkeys, the Winbar is hidden.

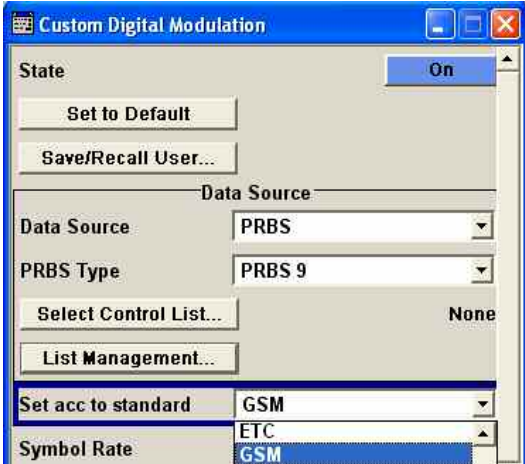



This section describes the menu structure. Menu operation is described in section section "[Menu Operation](#)", on page 3.26, the setting of parameters in section "[Setting Parameters](#)", on page 3.16.

The menus are in Windows format. They differ in details depending on their function but they consist of the same main elements.



### Menu header

The header line contains the name of the menu (e.g. Custom Dig. Mod.) and the buttons for minimizing  and closing  the menu. The buttons can be operated with the mouse. For operation from the front panel, the **HIDE** and **CLOSE** keys can be used.

The remaining menu area is variable and comprises various fields for setting parameters.

Each of the setting fields is assigned a parameter name. The kind of setting varies depending on the parameter to be set.

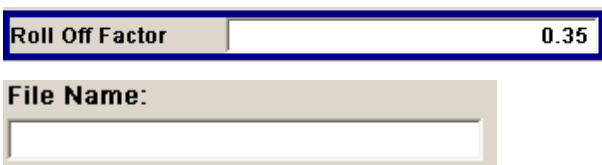

### Entry field

A numeric value (e.g. roll-off factor) or an alpha-numeric value (e.g. file name) can be entered in this field.

Set acc to standard	GSM
Symbol Rate	Bluetooth
Coding	DECT
	ETC
	<b>GSM</b>
	GSM EDGE
Modulation Type	NADC
	PDC
	PHS
	TETRA
	WCDMA-3GPP

**Selection field**

The  button indicates that a selection can be made from a list. The fold-down selection list is displayed below the selection field. Depending on the number of entries, the full list or only part of it is shown.

One entry at a time can be selected from the list. If an item is not available for selection, it is printed in grey and cannot be accessed.

Symbol Rate	270.833 333	ksym/s
Coding	GSM	sym/s
		<b>ksym/s</b>
Modulation		Msym/s

**Units**

The unit of a parameter is displayed next to the value. When the parameter is edited, the unit is selected either from the list or by means of the front-panel keys. When the entry is completed, the unit can be changed. In this case the value remains unchanged but is automatically adapted to the new unit.

Symbol Rate	270.833 333	ksym/s
Coding	GSM	sym/s
		ksym/s
Modulation		Msym/s

Ignore 1/4 sym (slot length 156 sym)	<input type="checkbox"/>
--------------------------------------	--------------------------

**Check-box field**

If the check box is ticked, the associated parameter setting is active (e.g. switched on).

Coding	GSM
	OFF
Modulation Type	<b>Differential</b>
	Phase Differential

**Access denied**

Some settings can only be made in a specific configuration. If setting is not permitted with the specific configuration selected, the respective item is disabled and displayed in grey and the entry or selection field cannot be accessed.

Impairments	
State	<input type="checkbox"/>
I Leakage	0.00 %
Q Leakage	0.00 %
Imbalance	0.00 %
Quadrature Offset	0.00 deg

**Menu area**

Several fields of associated but separately set parameters can be organized in a menu area. The menu area is framed and labelled with the function common to all parameters (e.g. Impairments).

	Chan Type	Enh Sett	Slot Form	Symb Rate kbps
0	P-CPICH	No		15
1	S-CPICH	No		15
2	P-SCH	No		15
3	S-SCH	No		15
4	P-CCPCH	Config...		<b>15</b>
5	S-CCPCH	No	#0	15

**Tables**

Tables are made up of a header, which normally contains the column labels, and lines containing the text.

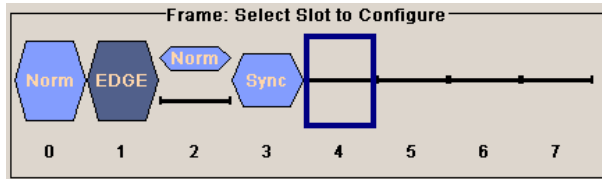

**Graphical display**

Graphical displays show signal characteristics and in some of them the element to be set can be selected.

Execute Single Sweep

Trigger/Marker...

Zoom in

Zoom out

**Buttons**

The buttons either trigger a single action (e.g. **Execute Single Sweep**), or call the next menu level (to be identified by 3 dots, e.g. **Markers...**). Some menus contain buttons that assign a function to the front-panel softkey below. These menus cover the Winbar.

**Graphical Display of Output Signal Characteristics**

The graphical display of the output signal enables the user to rapidly check signal characteristics without connecting an analyzer. Zoom functions and the display of a reference trace allow in-depth evaluation. The diagram is displayed on top of the block diagram. It can be minimized and called in the same way as a menu.

Example: I/Q diagram

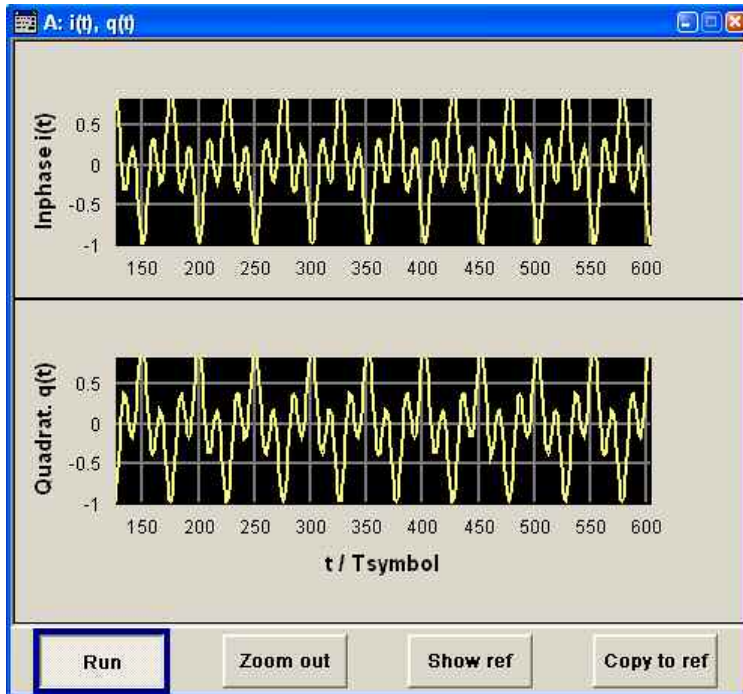

The **Graphics Settings** menu for selecting the graphics display of the output signal can be called either via the **Graphics** function block in the diagram or with the aid of the **MENU** key. Operation of the graphics windows is analogous to menu operation. The menu and the individual graphical displays are described in chapter 4, section "Graphics Display - Graphics".

## Setting Parameters

The R&S SMJ offers several and sometimes alternative possibilities for setting parameters. Operation is possible from the front panel, with the aid of a mouse and/or from a PC keyboard. Operation of the R&S SMJ with the aid of these control media is shown in the tables below.

Frequency and level are directly set in the header area of the display using the **FREQ** and **LEVEL** keys. Some of the keys trigger a direct action, e.g. the **RF ON/OFF** key switches the RF output on and off. An overview of key functions can be found at the end of this chapter (see section "[Legend of Front-Panel Controls](#)", on page 3.44), a detailed description of key functions is given in chapter 4, "Instrument Functions".

Most of the parameters are set in the menus. Menus can be opened from the function blocks of the diagram either with the aid of the rotary knob (= Enter) on the front-panel or by a mouse click on the **Config...** button.

An exception are the **Setup**, **File** and **Hcopy** menus. In the **Setup** menu, general settings are made which are not directly concerned with signal generation, e.g. setting of the IEC/IEEE-bus address. In the **File** menu, files and lists are managed; in the **Hcopy** menu, printout is configured and hardcopies can be made. These menus can only be called with the **SETUP**, **FILE** and **HCOPY** keys.

Specific settings can also be made directly in the block diagram, e.g. activating a function block by means of the **TOGGLE ON/OFF** key. Changes affecting the signal flow are immediately visible in the graphics display.

The R&S SMJ uses the Windows XP® operating system. Settings at system level are only rarely required, e.g. installation of a new printer driver. For convenient operation of Windows XP®, a keyboard and a mouse are required.

## Calling a Menu - Setting Parameters

After instrument switch-on, the cursor is always on the first function block of the diagram (default setting). It can be moved by means of the rotary knob or the arrow keys. Clicking the rotary knob opens the menu associated with the function block. The **MENU** key opens the complete menu tree.

With the aid of the appropriate keys and softkeys, the cursor can also be moved to the header area or the Winbar.

- ◆ The **FREQ** and **LEVEL** keys activate the frequency or level entry fields in the header area.
- ◆ The **DIAGRAM** key moves the cursor to the block diagram.
- ◆ The **WINBAR** key moves the cursor to the Winbar. The button that was active last in the Winbar is highlighted. The associated menu is activated by clicking the rotary knob (= Enter). If the Winbar was covered, it is now displayed in the foreground.
- ◆ A front-panel **softkey** immediately activates the associated menu and the cursor is on a parameter in this menu.
- ◆ The **MENU** key opens the complete menu tree, the **FILE** and **SETUP** keys the respective menus. Menus can be closed with the **CLOSE** key.

- ◆ The cursor can also be moved with the **[ESC]** key. However, the function of this key depends on the current cursor position:
  - **Parameter field** (editing mode):  
The editing mode is terminated and the previous value is restored (exception: value variations with the rotary knob cannot be cancelled).
  - **Menu area:**  
The cursor is set to another menu area.
  - **Menu:**  
The menu is closed and the cursor changes to the next higher control level.
  - **Frequency/level field:**  
The cursor is set on the previously active menu or, if no menu was active, on the first function block in the diagram.
  - **Function block in the diagram:**  
The cursor is set on the first menu in the winbar. If no menus are open, the current cursor position remains unchanged.

Function	Front panel	PC keyboard	Mouse
<b>Edits the frequency or level in the entry fields of the header area</b>	Press <b>[FREQ]</b> or <b>[LEVEL]</b> key. Enter value.	Press CTRL + F (frequency) or CTRL + L (level). Enter value.	Click the entry field and enter value.
<b>Activates the block diagram</b>	Press <b>[DIAGRAM]</b> key.	Press CTRL + D.	Click the function block.
<b>Activates the Winbar</b>	Press softkey. Press <b>[WINBAR]</b> key .	Press CTRL + F1... F8 Press CTRL + W.	Click button in Winbar.
<b>Calls the Setup or File menu or the menu tree</b>	Press <b>[SETUP]</b> , <b>[FILE]</b> or <b>[MENU]</b> key.	Press CTRL + S (Setup), CTRL + F (File) or CTRL + M (menu tree).	-

## Selecting a Control Element - Setting Parameters

Control elements are always selected in the same way no matter whether a function block in the diagram, a menu in the menu tree, a parameter in the menu or an entry in a list or table is concerned.

- An element is activated by means of the cursor. An active element is highlighted by a blue frame.



Function	Front panel	PC keyboard	Mouse
<b>Selects an element</b>	Select element by means of the rotary knob or the arrow keys.	Select element by means of the arrow keys.	Click element.

## Switching Parameters On/Off - Setting Parameters

A parameter can be activated and deactivated using a button or a check box.

- The ENTER function of the different control media switches the highlighted element on or off (toggle function). Colour and label of a button change, the check box is ticked or the tick is removed.



Function	Front panel	PC keyboard	Mouse
Switches on/off	Press rotary knob, <b>ENTER</b> or <b>TOGGLE ON OFF</b> key.	Press Enter key.	Click check box or button.

## Selecting and Exiting a Menu Area - Setting Parameters

Some menus are organized in areas. The cursor can be moved either only within an area or between the higher-level menu areas. This applies to the **File Select** menus when files are saved or loaded. When the menu is called, one of the menu areas is highlighted by a blue frame.

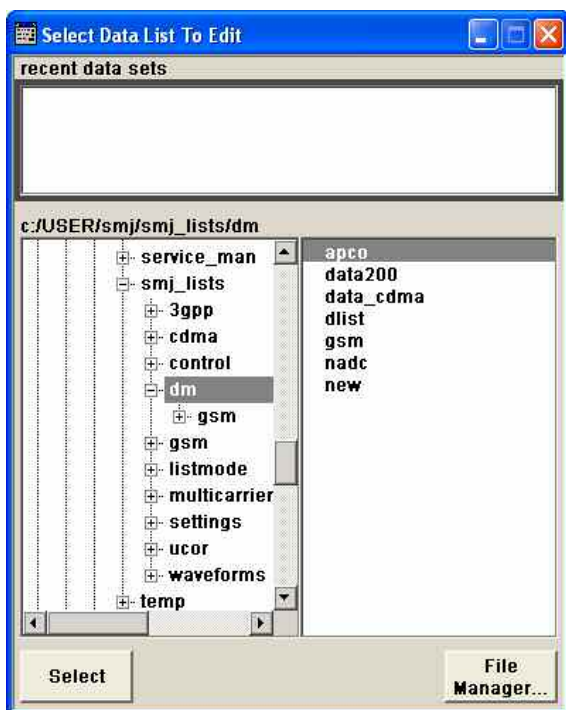

- Another menu area can be selected (highlighted) by means of the rotary knob or the arrow keys.

- Clicking the rotary knob (= Enter) moves the cursor to the highlighted menu area. When the cursor is placed on a lower-level area in the menu, the area is highlighted by a grey frame. The currently selected item is printed on a blue background (in the example the selected directory). The rotary knob and the arrow keys up/down move the cursor only within the grey-framed area.

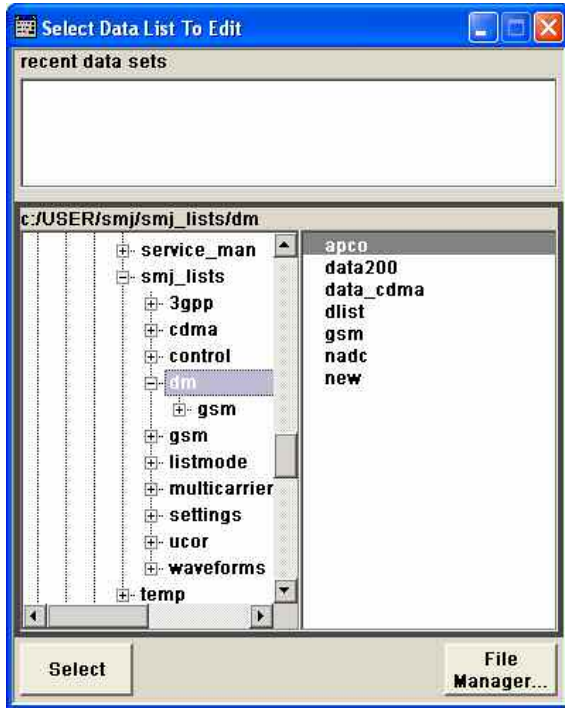

- Clicking the rotary knob (= Enter) terminates the setting, i.e. selection of a file. The cursor is either set on the next higher menu level or the menu is closed as in our example.
- The left/right cursor keys first shift the entry focus within the menu range from left to right (or vice versa); in the example, from the directory tree to the file list. Press again and the entry focus is shifted up one menu level. Clicking the rotary knob (= Enter) performs a setting. In the example of the **File Select** menu, this is the display of the subdirectories if a directory is marked and, if a file is marked, the selection of this file. After a file has been selected, the menu closes automatically. The **ESC** key moves the cursor to the next higher menu level.

Function	Front panel	PC keyboard	Mouse
<b>Selects a menu area</b>	Select menu area using the rotary knob or the arrow keys. Press the rotary knob or the <b>ENTER</b> key.  Rotary knob and arrow keys up/down move the cursor only within the selected menu area.	Select menu area using the arrow keys. Press the Enter key.  The arrow keys up/down move the cursor only within the selected menu area.	-  (The menu area is selected by selecting an entry.)
<b>Exits a menu area</b>	Press the <b>ESC</b> key.  Rotary knob or arrow keys move the cursor between different menu areas.	Press the Enter key.  The arrow keys move the cursor between different menu areas.	-  (The menu area is exited by setting the cursor on an item outside the area).

## Entering a Value - Setting Parameters

Numeric and alphanumeric values can be edited in the entry fields. In the editing mode, cursors of different colour are used. A blue cursor indicates the overwrite mode, a green cursor the insert mode. The **INSERT** key toggles between the two modes. The insert mode is the default setting.

Numeric values can either be newly entered or the existing value can be varied. Incorrect entries are cleared with the **BACK SPACE** key.

### Entering a new value:

A click on a numeric key activates the editing mode. The previous value is cleared and the new value can be entered.

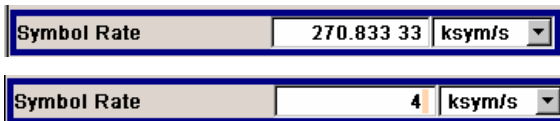

### Editing a value in the insert mode (default setting):

Clicking the rotary knob (= Enter) activates the editing mode. Set the cursor to the left of the number to be changed using the left/right arrow keys. The cursor is displayed in green. A change to the overwrite mode is possible any time. In this case the cursor changes its colour and the number to be replaced is highlighted. If the cursor is placed at the right of the total value, the insert mode is always active.

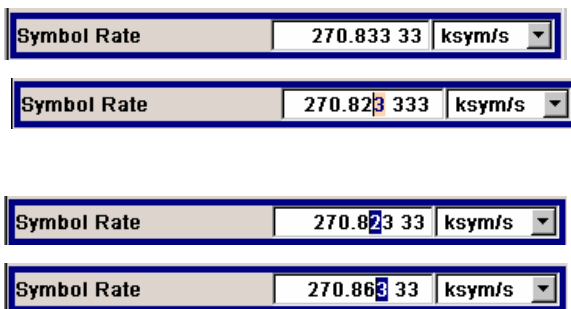

### Editing a value in the overwrite mode:

Clicking the rotary knob (= Enter) activates the editing mode. Set the cursor on the number to be varied using the left/right arrow keys. In the overwrite mode, the cursor is blue. The highlighted value is overwritten by clicking a numeric key.

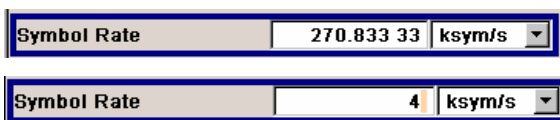



**Variation:**

Clicking the rotary knob (= Enter) activates the editing mode. Set the cursor to the left of the number to be changed using the left/right arrow keys. The value at the cursor position is varied. An increase or decrease of the value depends on the cursor used (up/down) or on the direction of rotation of the rotary knob.

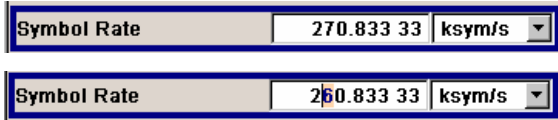

Alphanumeric values can either be newly entered or existing values can be edited (e.g. file name).

**New entry:**

The entry is started by clicking an alphanumeric key.



**Editing:**

An existing value, e.g. a file name, can be changed in the insert mode (see example) or in the overwrite mode.



Function	Front panel	PC keyboard	Mouse
Enters a new value	Press an alphanumeric key. If <b>hexadecimal values</b> are to be entered, the numeric front-panel keys are automatically changed to hexadecimal values.	Press a letter key or a numeric key.	-
Edits a value	Click the rotary knob. Select the desired numeric digit with the rotary knob and mark it by clicking the button. Change the number using the keypad.  Use the <b>INSERT</b> key to toggle between the insert and overwrite mode.	Press the Enter key. Select the desired numeric digit using the left/right arrow keys. Enter new value using the keyboard.  Use the Insert key to toggle between the insert and the overwrite mode.	Click the desired position to set the cursor. Change the value using the keyboard.
Varies a value	Click the rotary knob. Select the desired numeric digit with the rotary knob and mark it by clicking the button. Vary the number using the rotary knob.	Press the Enter key. Select the desired numeric digit using the left/right arrow keys. Vary the number using the up/down arrow keys.	-

## Selecting a Unit - Setting Parameters

The entry of a numeric value can be terminated by pressing a unit key on the front panel, selecting a unit in the selection field next to the value or by clicking the rotary knob (= Enter). The unit is assigned in different ways:

### Terminating the value entry by pressing the unit key

When the entry is terminated with a unit key on the front panel, the key assigns the unit to the value. In the example, the M/μ key assigns Msym/s to the entered value 14.



### Terminating the value entry by selecting a unit in the units field

When the entry is terminated by selecting a unit in the units field next to the value, the selected unit is assigned, e.g. sym/s (for list selection see next section).

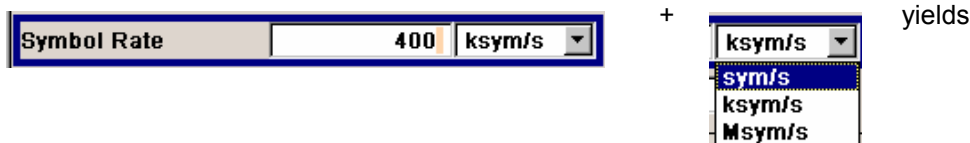

### Terminating the value entry with Enter

If an entry is terminated by clicking the rotary knob (= Enter) or with the **ENTER** key, the unit displayed in the entry field next to the value is assigned (in the example ksym/s).



If a unit is subsequently changed, i.e. after the entry has been terminated and when the editing mode is not active, the value remains unchanged but the display is automatically adapted to the new unit. This applies if the unit is changed by means of the unit keys on the front panel or via the unit field next to the value.

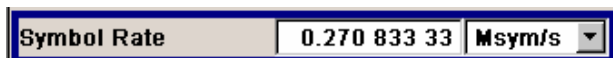
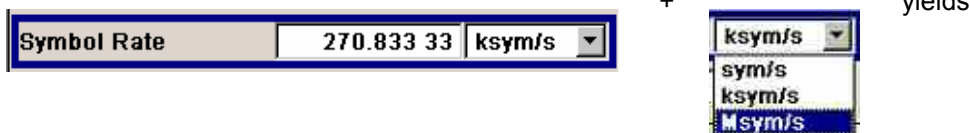





Function	Front panel	PC keyboard	Mouse
Assigns a unit	To terminate the entry, press one of the <b>unit</b> keys or select unit in the field at the right of the value (for list selection see next section).	To terminate the entry press one of the key combinations ALT + F9/ + F10/+ F11/+ F12 or select unit in the field at the right of the value (for list selection see next section).	Select unit in the field at the right of the value <b>before</b> entering the value (for list selection see next section).
Changes a unit	After the value entry has been terminated press a <b>unit</b> key or select unit in the field at the right of the value (for list selection see next section).	After the value entry has been terminated press one of the key combinations ALT + F9/+ F10/+ F11/+ F12 or select unit in the field at the right of the value (for list selection see next section).	Select unit in the field at the right of the value <b>after</b> the value entry (for list selection see next section).

### Selecting a Value from a List - Setting Parameters

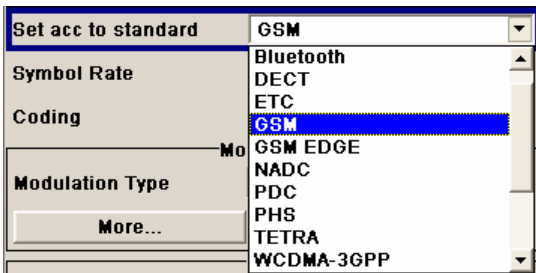
The  button next to the value field indicates that a selection list is available.

- Clicking the rotary knob (= Enter) opens the list. Selection is made by choosing an entry (item is highlighted) and confirmation with ENTER. If the list is longer than the displayed window, a scroll bar is available.



Function	Front panel	PC keyboard	Mouse
Opens the selection list	Press rotary knob or <b>ENTER</b> key.	Press Enter key.	Click  button.
Selects an entry	Select entry using the rotary knob or the up/down arrow keys and confirm with the rotary knob or the <b>ENTER</b> key or press <b>ON/OFF TOGGLE</b> key several times until the desired entry is displayed in the selection field.	Select entry using the up/down arrow keys and confirm with the Enter key.	Double-click the desired entry.
Scrolls	Shift the displayed list section using the rotary knob or the up/down arrow keys.	Shift the displayed list section using the up/down arrow keys.	Press  or  button in the scroll bar until the desired entry is displayed.

## Terminating Entries - Setting Parameters

Variations by means of the rotary knob are immediately set, e.g. RF frequency variation.

All other parameter settings have to be confirmed by a pressing the rotary knob or one of the unit keys (see also section "Selecting a Unit", page 3.22).

Some settings require additional confirmation with the **Accept** button. This is the case when it is useful to first enter a few values and to confirm them together, e.g. when carriers for a multicarrier CW signal are defined in the carrier table. Settings not yet confirmed by **Accept** are displayed in the menu on a yellow background. This indicates that the currently displayed values do not represent the desired signal.

All settings of instrument functions that can be switched on and off are calculated and effective only after this function has been switched on.

This applies to most settings on the R&S SMJ. An exception is, for instance, the frequency variation of the reference oscillator, which is immediately set after confirmation.

Calculation and setting may take up different periods of time. Many settings are made without noticeable calculation times. If a short period is required, **BUSY** is displayed during this time in the status field of the header section. If more time is required for calculation, a window with a progress bar is displayed.

Calculation can be aborted with the **Abort** button in this window.

If time-consuming calculations are required, signal generation is automatically switched off and calculation is interrupted to allow the user to make further settings. Calculation is restarted with the **RECALCULATE** key and the modulation is switched on again when the calculation is completed.

**Hint:**

*If several settings are to be made for an instrument function, recalculation of the signal can be prevented by switching the function off. When the function is switched on again after all parameter have been changed, the signal is recalculated only once.*

Function	Front panel	PC keyboard	Mouse
<b>Accepts value immediately</b>	Vary the value using the rotary knob or the up/down arrow keys.	Vary the value with the up/down arrow keys.	-
<b>Confirms entries</b>	Press rotary knob or <b>ENTER</b> key or press <b>unit</b> key.	Press Enter key or one of the key combinations ALT + F9/+ F10/+ F11/+ F12.	Exit entry field.
<b>Confirms entries in the menus with the <b>Accept</b> button.</b>	Press <b>Accept</b> button.	Select <b>Accept</b> button with the arrow keys and press Enter.	Click <b>Accept</b> button.
<b>Sets the entries in the instrument</b>	If the instrument function is active, the new value is immediately calculated and set.  If the instrument function is not active, the new, confirmed value is calculated and set only when the function is switched on.	(see front panel)	(see front panel)

## Restoring the Previous Value - Setting Parameters

Parameter variations with the rotary knob are immediately set and therefore not reversible.

Normally, values cannot be restored also in the case of mouse control because no explicit confirmation is required in this case and entries are automatically confirmed when the entry or selection field is exited.

In the case of front-panel control or operation from the keyboard, previous values can be restored as long as the new value is not confirmed, i.e. the entry is not completed. This can be done with the **ESC** key.

With settings requiring an additional confirmation with the **Accept** button, all settings are aborted when the **ESC** key is pressed. Before the changes are aborted, a confirmation query is displayed. If **OK** is clicked, the changes are aborted; if **Cancel** is clicked, the menu with the previous settings is displayed again.

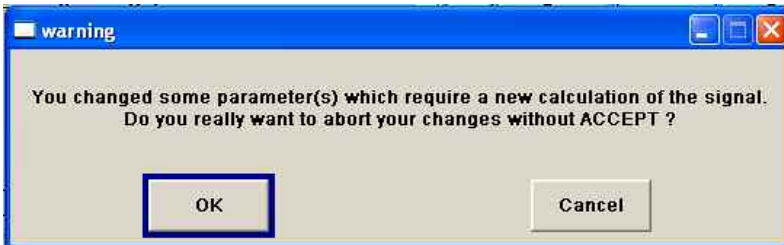

When a window with a progress bar is displayed in the case of extended calculations, the calculation can be terminated with the **Abort** button. In this case all previous values are restored.

Function	Front panel	PC keyboard	Mouse
Restores previous values	Press the <b>ESC</b> key before the entries are confirmed.	Press the Esc key before the entries are confirmed.	-
Restores all previous values in menus with <b>Accept</b> button	Press the <b>ESC</b> key. Answer the confirmation query with OK (see above).	Press the Esc key. Answer the confirmation query with OK (see above).	Click the <b>X</b> button. Answer the confirmation query with OK (see above).
Restores all previous values after an extended calculation has been started	Press the <b>Abort</b> button in the progress bar.	Select the <b>Abort</b> button in the progress bar using the arrow keys and press the Enter key.	Click the <b>Abort</b> button.

# Menu Operation



Menus are operated with the aid of the Winbar buttons or front-panel softkeys and with the **HIDE**, **CLOSE**, **DIAGRAM** and **REARR** keys on the front panel.

If the Winbar is covered by a menu, it can be called to the front with the **WINBAR** key.

- ◆ The **DIAGRAM** key moves the cursor to the block diagram. All active menus are minimized and displayed in the form of Winbar buttons.
- ◆ The **CLOSE** key closes an active menu.
- ◆ The **HIDE** key minimizes an active menu. It is displayed in the form of a Winbar button.
- ◆ The **REARR** key rearranges all open menus so that they overlap as little as possible.
- ◆ The **WINBAR** key toggles the cursor between a Winbar button and the block diagram.
- ◆ The softkeys call or close the associated menu and set the cursor in the menu.

**Note:**

The **ESC** key also closes the active menu if the cursor is at the highest menu level.

Function	Front panel	PC keyboard	Mouse
<b>Displays the block diagram in the foreground</b>	Press the <b>DIAGRAM</b> key.	Press CTRL + D.	Click function block.
<b>Displays a menu in the foreground</b>	Press the associated softkey.	Press CTRL + F1 to F8.	Click the respective button in the Winbar.
<b>Minimizes an active menu</b>	Press the <b>HIDE</b> key.	Press CTRL + H.	Click the  button in the menu bar.
<b>Closes an active menu</b>	Press the <b>CLOSE</b> key.	Press CTRL + G.	Click the  button in the menu bar.
<b>Hides all menus</b>	Click the <b>DIAGRAM</b> key.	Press CTRL + D.	-
<b>Automatically arranges displayed menus</b>	Click the <b>REARR</b> key.	Press CTRL + A.	- The menus can be shifted with the mouse as required. The frequency and level fields and the info line cannot be covered, however.

## Editors

The R&S SMJ provides user-friendly editors for defining data lists as well as control and marker signals. Lists containing frequency and level value pairs are used for the list mode and the user-defined level correction. Internally generated data lists can be used for digital modulation and digital standards; the same applies to internally defined control and marker signals.

The lists are saved to files and may thus have any length. The file name of the lists and the directory to which the files are saved are user-selectable. The file prefix is different for each list type and is permanently assigned by the system (see section "File Management", page 3.37).

### List Editor

The **User Correction** and **List Mode** menus provide the list editor for defining the frequency/level value pairs. The associated buttons call up the list editor.

Edit User Correction Data...

Edit List Mode Data...

- ◆ The selected list is displayed. If no list has been selected, a blank list of only one row is displayed.

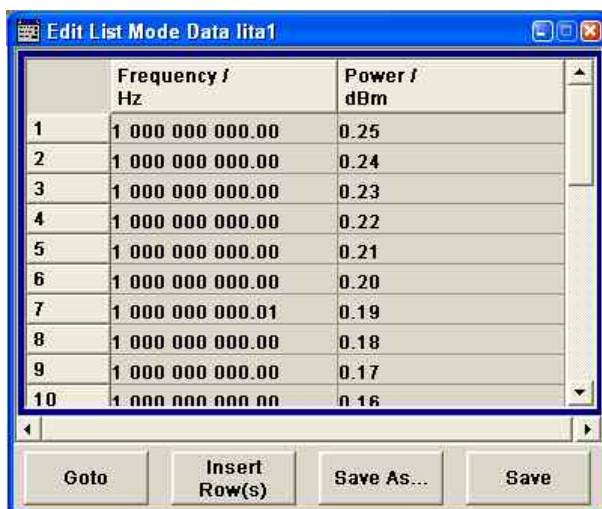

- ◆ The value pairs are entered in the **Frequency/Hz** and **Power/dBm** table columns. A blank row is inserted at the end of the list.
- ◆ New rows can be inserted anywhere in the table by means of the **Insert Row(s)...** button.
- ◆ After the list has been edited, i.e. changed, it can be saved under its current name by means of the **Save** button, or under a new name by means of the **Save as...** button. Only complete value pairs are taken into consideration; rows containing an entry in only one column are ignored.
- ◆ An existing list can be edited in the insert or overwrite mode.
- ◆ A new list can be created under a new name either by generating a blank file in the **File Select** menu (see section "File Management", page 3.37) or by changing an existing list which will then be saved under a new name.

Function	Front panel	PC keyboard	Mouse
<p><b>Call up editor</b></p> <p>The cursor marks the first row of the Frequency/Hz column.</p>	<p>Use the rotary knob or the cursor keys to mark the <b>Edit xxx Data...</b> button in the individual menu, click the rotary knob or press the <b>ENTER</b> key.</p>	<p>Mark the <b>Edit xxx Data...</b> button in the individual menu and press the Enter key.</p>	<p>Click the <b>Edit xxx Data...</b> button in the individual menu.</p>
<p><b>Enter value</b></p>	<p>Use the numeric keys to enter the value and terminate the entry by pressing the unit key.</p>	<p>Use the numeric keys to enter the value and terminate the entry by pressing the Enter key.</p>	<p>-</p>
<p><b>Change column</b></p>	<p>Press the left/right cursor keys.</p>	<p>Press the left/right cursor keys.</p>	<p>Click cell.</p>
<p><b>Change row</b></p>	<p>Use the rotary knob or the up/down cursor keys to mark the row.</p>	<p>Use the up/down cursor keys to mark the row.</p>	<p>Click cell.</p>
<p><b>Select row</b></p> <p>The cursor moves to the selected row.</p>	<p>Use the rotary knob or the cursor keys to mark the <b>GoTo</b> button, click the rotary knob or press the <b>ENTER</b> key.</p> <p>Enter the row index in the entry field by means of the numeric keys, click the rotary knob or press the <b>ENTER</b> key.</p>	<p>Mark the <b>GoTo</b> button and press the Enter key.</p> <p>Use the numeric keys to enter the row index and terminate the entry by pressing the Enter key.</p>	<p>Click cell.</p>
<p><b>Insert row</b></p> <p>A row is inserted above the currently marked row.</p> <p>If no row has been selected, a row is inserted at the beginning of the list.</p>	<p>Select the row above which the new row is to be inserted.</p> <p>Use the rotary knob or the cursor keys to mark the <b>Insert Row(s)</b> button, click the rotary knob or press the <b>ENTER</b> key.</p>	<p>Select the row above which the new row is to be inserted.</p> <p>Mark the <b>Insert Row(s)</b> button and press the Enter key.</p>	<p>Click the row above which the new row is to be inserted.</p> <p>Click the <b>Insert Row(s)</b> button.</p>
<p><b>Save list under a new name</b></p>	<p>Use the rotary knob or the cursor keys to mark the <b>Save as..</b> button, click the rotary knob or press the <b>ENTER</b> key.</p> <p>Enter the file name in the File Select menu and select the directory (see section "File Select Menu", page 3.38).</p>	<p>Mark the <b>Save as..</b> button and press the Enter key.</p> <p>Enter the file name in the File Select menu and select the directory (see section "File Select Menu", page 3.38).</p>	<p>Double-click the <b>Save as..</b> button.</p> <p>Enter the file name in the File Select menu and select the directory (see section "File Select Menu", page 3.38).</p>
<p><b>Save list under the same name</b></p>	<p>Use the rotary knob or the cursor keys to mark the <b>Save</b> button, click the rotary knob or press the <b>ENTER</b> key.</p>	<p>Mark the <b>Save</b> button and press the Enter key.</p>	<p>Double-click the <b>Save</b> button.</p>
<p><b>Create new list</b></p>	<p>Mark the <b>List Mode Data</b> or <b>User Correction Data</b> button, click the rotary knob or press the <b>ENTER</b> key.</p> <p>Mark Create New List, click the rotary knob or press the <b>ENTER</b> key.</p> <p>Enter the file name in the File Select menu and select the directory (see section "File Select Menu", page 3.38).</p>	<p>Mark the <b>List Mode Data</b> or <b>User Correction Data</b> button and press the <b>ENTER</b> key.</p> <p>Mark Create New List and press the Enter key.</p> <p>Enter the file name in the File Select menu and select the directory (see section "File Select Menu", page 3.38).</p>	<p>Double-click the <b>List Mode Data</b> or <b>User Correction Data</b> button.</p> <p>Double-click Create New List.</p> <p>Enter the file name in the File Select menu and select the directory (see section "File Select Menu", page 3.38).</p>



## Data Editor

The **Data Editor** can be used to internally generate binary data lists for digital modulation and digital standards.

A list of binary values with a maximum length of  $2^{31}$  bits can be entered in the **Data Editor**. This value corresponds to a file size of approx. 268 Mbyte. While it is being processed, the file is continuously automatically buffered. When the menu is exited, the file is automatically saved with the new values, i.e. there is no extra **Save** button. Depending on the size of the file, saving may take some time.

It is called up in the individual menus by means of the **Edit Data List...** button.

- ◆ The selected data list is displayed.

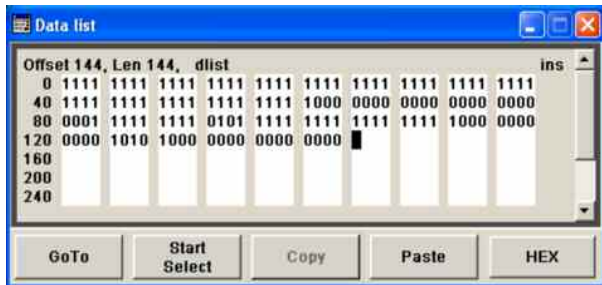

- ◆ To increase readability, the bits are displayed in groups of four. The current cursor position, the length of the list and the list file name are displayed above the list. The offset starts with the value 0 which corresponds to the bit position on the left side of the first row, i.e. the beginning of the list. On the left edge of the editor, the last three offset positions are specified at the beginning of the row.
- ◆ An existing list can be edited in the insert or overwrite mode.
- ◆ By means of the **GoTo** button, any bit position can be accessed.
- ◆ By means of the **Start Select**, **Copy** and **Paste** buttons, any range of bits can be marked, copied and subsequently pasted at any position in the list.
- ◆ By means of the **HEX** button, switchover to hexadecimal display is possible.
- ◆ For a new list to be edited, it must first be created in the **File Select** menu (see section "[File Management](#)", page 3.37) and then selected.

Function	Front panel	PC keyboard	Mouse
Call up editor. The cursor marks the start value of the list.	Use the rotary knob or the cursor keys to mark the <b>Edit Data List...</b> button in the list management submenu of the individual menu, click the rotary knob or press the <b>ENTER</b> key.	Mark the <b>Edit Data List...</b> button in the list management submenu of the individual menu and press the Enter key	Click the <b>Edit Data List...</b> button in the list management submenu of the individual menu.
Enter value. Depending on selected mode, either insertion or overwrite, the value is either inserted or it replaces an existing value.	Use the numeric keys to enter the values 0 or 1.	Use the numeric keys to enter the values 0 or 1.	-

Function	Front panel	PC keyboard	Mouse
<p>Delete value.</p> <p>The value before the marked bit is deleted.</p>	<p>Use the rotary knob or the cursor keys to mark the bit that follows the value to be deleted.</p> <p>Press the <b>INSERT</b> key to activate the insertion mode. Values cannot be deleted in the overwrite mode.</p> <p>Press the <b>BACKSPACE</b> key.</p>	<p>Use the cursor keys to mark the bit that follows the value to be deleted.</p> <p>Press the Insert key to activate the insertion mode. Values cannot be deleted in the overwrite mode.</p> <p>Press the Backspace key.</p>	-
<p>Select bit position.</p> <p>The cursor marks the bit at the selected position.</p>	<p>Use the rotary knob or the cursor keys to mark the <b>GoTo</b> button, click the rotary knob or press the <b>ENTER</b> key.</p> <p>Enter the bit position in the GoTo Offset entry field by means of the numeric keys, click the rotary knob or press the <b>ENTER</b> key.</p>	<p>Mark the <b>GoTo</b> button and press the Enter key.</p> <p>Use the numeric keys to enter the bit position in the Offset entry field and terminate the entry by pressing the Enter key.</p>	Click bit.
<p>Copy and paste bits.</p> <p>The selected and copied bits are pasted after the selected position.</p>	<p>Use the rotary knob or the cursor keys to mark the start bit of the selection.</p> <p>Press the <b>ESC</b> key. Use the rotary knob or the cursor keys to mark the <b>Start Select</b> button, click the rotary knob or press the <b>ENTER</b> key.</p> <p>Use the rotary knob or the cursor keys to mark the selection.</p> <p>Press the <b>ESC</b> key. Use the rotary knob or the cursor keys to mark the <b>Copy</b> button, click the rotary knob or press the <b>ENTER</b> key.</p> <p>Use the rotary knob or the cursor keys to mark the insert position.</p> <p>Press the <b>ESC</b> key. Use the rotary knob or the cursor keys to mark the <b>Paste</b> button, click the rotary knob or press the <b>ENTER</b> key.</p>	<p>Move the cursor to the start of the selection.</p> <p>Press the ESC key. Mark the <b>Start Select</b> button and press the Enter key.</p> <p>Move the cursor to the end of the selection.</p> <p>Press the ESC key. Mark the <b>Copy</b> button and press the Enter key.</p> <p>Move the cursor to the insert position.</p> <p>Press the ESC key. Mark the <b>Paste</b> button and press the Enter key.</p>	<p>Click the bit at the start of the selection.</p> <p>Click the <b>Start Select</b> button.</p> <p>Click the bit at the end of the selection.</p> <p>Click the <b>Copy</b> button.</p> <p>Click the bit position after which the copied bits should be pasted.</p> <p>Click the <b>Paste</b> button.</p>
<p>Display and edit the values in hexadecimal form.</p> <p>Each four bits are displayed as a hexadecimal value: To increase readability, the hexadecimal values in turn are displayed in pairs of two. The hex functions are automatically assigned to the numeric keys at the front panel.</p>	<p>Use the rotary knob or the cursor keys to mark the <b>Hex</b> button, click the rotary knob or press the <b>ENTER</b> key.</p>	<p>Mark the <b>Hex</b> button and press the Enter key.</p>	Click the <b>Hex</b> button.
<p>Save list.</p> <p>The list is saved automatically when the menu is closed.</p>	<p>Press the <b>ESC</b> key.</p>	<p>Press the ESC key.</p>	Click the <b>X</b> button in the menu bar.

Function	Front panel	PC keyboard	Mouse
Create new list.	<p>Mark the <b>Data List...</b> button in the list management submenu of the individual menu, click the rotary knob or press the <b>ENTER</b> key.</p> <p>Mark Create New List, click the rotary knob or press the <b>ENTER</b> key.</p> <p>Enter the file name in the File Select menu and select the directory (see section "File Select Menu", page 3.38).</p>	<p>Mark the <b>Data List...</b> button in the list management submenu of the individual menu and press the Enter key.</p> <p>Mark Create New List and press the Enter key.</p> <p>Enter the file name in the File Select menu and select the directory (see section "File Select Menu", page 3.38)</p>	<p>Double-click the <b>Data List...</b> button in the list management submenu of the individual menu.</p> <p>Double-click Create New List.</p> <p>Enter the file name in the File Select menu and select the directory (see section "File Select Menu", page 3.38)</p>

## Control and Marker List Editor

The control and marker signals for digital modulation and digital standards can be very conveniently graphically defined in a **Control and Marker List Editor**.

The four available marker signals – and, with custom digital modulation, the CW, Hop, Burst Gate and Lev Att control signals – can be defined in the **Control and Marker List Editor**. While it is being processed, the file is continuously automatically buffered. When the menu is exited, the file is automatically saved with the new values, i.e. there is no extra **Save** button. Depending on the size of the file, saving may take some time. The **Control List Editor** is called up in the Custom Digital Mod menus by means of the **Edit Control List...** button.

The **Slot Marker Definition** Editor is called up in the Burst submenu of the GSM/EDGE menus by means of the **Slot Marker Definition...** button.

The following figure shows the **Slot Marker Definition** Editor of the GSM/EDGE menu as an example.



- ◆ The upper area displays the signal (in the example, the GSM slot) for which the marker signals are to be defined. On the left side, the available signals (marker and control signals) are listed and colour-coded.
- ◆ Auxiliary functions are offered in the lower editor area, e.g. presetting for the ramps in the marker signal, cursor positioning by entering the bit position and possible editing by means of value entries in a table.
- ◆ The actual graphic definition of the control signals occurs in the center area of the editor. Each control signal is represented by means of a colored line along the bit axis. A cursor can be shifted alongside this line and marks the position where a ramp is to be set.

The color of the cursor changes depending on the current function. The switch over between the colors (and therefore functions) is by means of the Enter key:

black	marks the bit position on the marker line
yellow	sets a ramp
green	activates the marked ramp for shifting

- ◆ The ramp transition of the newly set ramp depends on the current status (high/low) of the control signal. If the signal is low, a ramp with low/high transition is generated; if the signal is high, a ramp with high/low transition is generated.

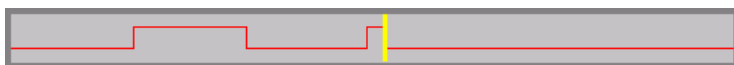

When ramps are set between existing ramps, the transition of the new ramp is also defined by the status of the signal before the new ramp. For this reason, a ramp that has already been set can be assigned low/low or high/high transition (as in the example), i.e. it will have no effect on the control signal in this configuration. However, the ramp remains saved, and its position is indicated by a dashed line.

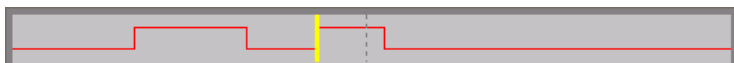

If another change produces effective transition, this ramp will be regenerated.

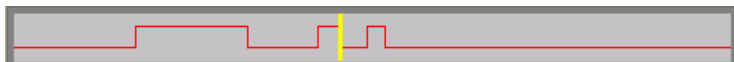

- ◆ An existing ramp can be shifted to any positions. The transitions are adjusted accordingly.



- ◆ To make the setting easy, a selection of preset ramp characteristics is offered in the **Preset Signal** area.
- ◆ In the **Cursor** area, the cursor can be specifically set to a defined bit position in the data signal.
- ◆ The ramps can also be set in the table in the **Marker Positions** area.

The various functions of the editor are explained in the individual menus. The following table explains only the general use of the graphic editor.

Function	Front panel	PC keyboard	Mouse
<p><b>Call up editor</b></p> <p>The cursor marks the first control signal in the list on the left side of the menu.</p>	<p>Use the rotary knob or the cursor keys to mark the button in the individual menu, click the rotary knob or press the <b>ENTER</b> key.</p>	<p>Mark the button in the individual menu and press the Enter key.</p>	<p>Click the button in the individual menu.</p>
<p><b>Activate control/marker signal line for editing</b></p> <p>The cursor is active for the selected line.</p>	<p>Use the rotary knob or the cursor keys to mark the editable graphic area, click the rotary knob or press the <b>ENTER</b> key.</p> <p>Use the rotary knob or the cursor keys to mark the control/marker signal line, click the rotary knob or press the <b>ENTER</b> key.</p>	<p>Use the cursor keys to mark the editable graphic area and press the Enter key.</p> <p>Use the cursor keys to mark the control/marker signal line and press the Enter key.</p>	<p>Click row.</p>
<p><b>Set ramp</b></p> <p>The ramp transition depends on the status (high/low) of the control/marker signal before the ramp.</p>	<p>Use the rotary knob or the cursor keys to move the cursor to the position where the ramp is to be inserted. Click the rotary knob or press the <b>ENTER</b> key.</p>	<p>Use the cursor keys to move the cursor to the position where the ramp is to be inserted. Press the Enter key.</p>	<p>Double click cursor; the cursor changes colour and the ramp is inserted.</p>
<p><b>Shift ramp</b></p> <p>The ramp transition depends on the status (high/low) of the control/marker signal before the ramp.</p>	<p>Use the rotary knob or the cursor keys to move the cursor to the ramp position; the cursor changes colour.</p> <p>Click the rotary knob or press the <b>ENTER</b> key. The cursor again changes colour. The ramp will now be shifted by means of the cursor.</p> <p>Click the rotary knob or press the <b>ENTER</b> key. The ramp will be set at the current position.</p>	<p>Use the cursor keys to move the cursor to the ramp position; the cursor changes colour.</p> <p>Press the Enter key. The cursor again changes colour. The ramp will now be shifted by means of the cursor.</p> <p>Press the Enter key. The ramp will be set at the current position.</p>	<p>After double-clicking the cursor, click it once again and, while holding down the left-hand mouse button, drag it. The cursor changes colour.</p> <p>The ramp is set as soon as the left-hand mouse button is released.</p>
<p><b>Delete ramp</b></p> <p>The ramp transitions of the other ramps are adapted to the changed signal status (high/low).</p>	<p>Use the rotary knob or the cursor keys to move the cursor to the ramp position; the cursor changes colour.</p> <p>Press the <b>BACKSPACE</b> key. The ramp will be deleted.</p>	<p>Use the cursor keys to move the cursor to the ramp position; the cursor changes colour.</p> <p>Press the Delete key. The ramp will be deleted.</p>	<p>-</p>
<p><b>Define length of control list (Custom Dig Mod only)</b></p>	<p>Use the rotary knob or the cursor keys to mark the Total List Length entry field, click the rotary knob or press the <b>ENTER</b> key.</p> <p>Enter the length by means of the numeric keys.</p> <p>Click the rotary knob or press the <b>ENTER</b> key. The control list length is defined.</p>	<p>Use the cursor keys to mark the Total List Length entry field and press the Enter key.</p> <p>Enter the length by means of the numeric keys.</p> <p>Press the Enter key. The control list length is defined.</p>	<p>-</p>

Function	Front panel	PC keyboard	Mouse
<p><b>Zoom displayed range</b> (Custom Dig Mod only)</p> <p>Approx. 300 bits around the current cursor position are displayed.</p>	<p>Use the rotary knob or the cursor keys to mark the <b>Zoom in</b> button, click the rotary knob or press the <b>ENTER</b> key.</p>	<p>Use the cursor keys to mark the <b>Zoom in</b> button and press the Enter key.</p> <p>Enter the length by means of the numeric keys.</p> <p>Press the Enter key. The control list length is defined.</p>	<p>Click the <b>Zoom in</b> button.</p>
<p><b>Save list</b></p> <p>The list is saved automatically when the menu is closed.</p>	<p>Press the <b>ESC</b> key.</p>	<p>Press the ESC key.</p>	<p>Click the <b>X</b> button in the menu bar.</p>
<p><b>Create new list</b> (Custom Dig Mod only)</p>	<p>Mark the <b>Control List...</b> button in the list management submenu of the individual menu, click the rotary knob or press the <b>ENTER</b> key</p> <p>Mark Create New List, click the rotary knob or press the <b>ENTER</b> key.</p> <p>Enter the file name in the File Select menu and select the directory (see section "File Select Menu", page 3.38).</p>	<p>Mark the <b>Control List...</b> button in the list management submenu of the individual menu and press the <b>ENTER</b> key</p> <p>Mark Create New List and press the Enter key.</p> <p>Enter the file name in the File Select menu and select the directory (see section "File Select Menu", page 3.38).</p>	<p>Double-click the <b>Control List...</b> button in the list management submenu of the individual menu.</p> <p>Double-click Create New List.</p> <p>Enter the file name in the File Select menu and select the directory (see section "File Select Menu", page 3.38).</p>

# Help system

The R&S SMJ is equipped with a context-sensitive help function. A help page is available for each parameter and can be called any time during instrument operation. The context-sensitive page which is opened with the **[HELP]** key is part of a comprehensive help system. It is possible to move from this context-sensitive page to any page of the help system.

**Note:**

*Compiled online help systems are also available for all functions of the R&S SMJ on the CD-ROM supplied with the instrument. This help program can be called on any controller with Internet Explorer version V 4.0 and higher.*

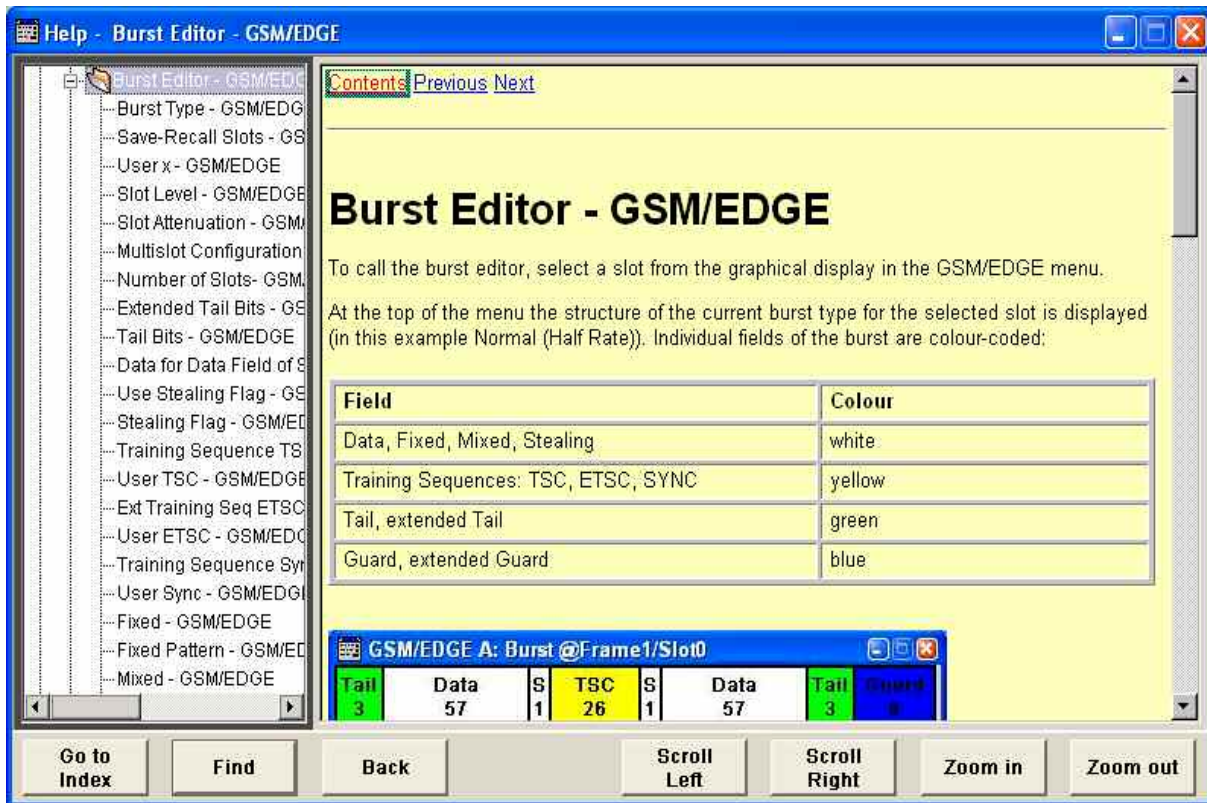

The help function is provided with a navigation bar, i.e. other help pages can be called from the context-sensitive page via the table of contents, the index, arrows for scrolling and page-internal links.

Operation of context-sensitive help

Function	Front panel	PC keyboard	Mouse
<p><b>Open the help system</b></p> <p>The help page for the respective parameter is displayed.</p>	Press <b>HELP</b> key.	Press F1 key.	-
<p><b>Close the help system</b></p>	Press <b>HELP</b> key again.	Press F1 key again.	-
<p><b>Activate the link</b></p> <p>The help system branches to the linked page.</p>	Select link with rotary knob or arrow keys and activate by clicking the rotary knob or <b>ENTER</b> key.	Select link using the arrow keys and activate with the Enter key.	Click link.
<p><b>Scroll</b></p>	Select <b>Previous</b> or <b>Next</b> in the help window using the arrow keys and activate by clicking the rotary knob or the <b>ENTER</b> key.	Select <b>Previous</b> or <b>Next</b> in the help window using the arrow keys and activate with the Enter key.	Click <b>Previous</b> or <b>Next</b> .
<p><b>Select an item in the table of contents</b></p> <p>The help page of the item is displayed.</p>	<p>Activate Content window using the arrow keys left/right.</p> <p>Select the desired item using the rotary knob or the arrow keys up/down and activate by clicking the rotary knob or the <b>ENTER</b> key.</p>	<p>Activate Content window using the arrow keys left/right.</p> <p>Select the desired item using the arrow keys and activate with Enter.</p>	<p>Set indicated area by moving the vertical scroll bar.</p> <p>Click item.</p>
<p><b>Select an index term</b></p> <p>The help page of the term is displayed.</p>	<p>Select <b>Go-to-Index</b> button using the arrow keys and activate by clicking the rotary knob or the <b>ENTER</b> key.</p> <p>Enter the first letter of the term in the entry field.</p> <p>Select the term using the rotary knob or the arrow keys and press the rotary knob or the <b>ENTER</b> key.</p>	<p>Select the <b>Go-to-Index</b> button using the arrow keys and activate with the Enter key.</p> <p>Enter the first letter of the term and press the Enter key.</p> <p>Select the term with the arrow keys and press the Enter key.</p>	<p>Click the <b>Go-to-Index</b> button.</p> <p>Set indicated area by moving the vertical scroll bar.</p> <p>Click term.</p>
<p><b>Shift the indicated area of the navigation window to the left or right</b></p>	<p>Shift the entry focus up one level using the <b>ESC</b> key.</p> <p>Select <b>Scroll Right</b> or <b>Scroll Left</b> -button using the arrow keys and activate by clicking the rotary knob or the <b>ENTER</b> key.</p>	<p>Shift the entry focus up one level using the Esc key.</p> <p>Select <b>Scroll Right</b> or <b>Scroll Left</b> -button using the arrow keys and activate with the Enter key.</p>	<p>Set indicated area by moving the horizontal scroll bar.</p>



## File Management

The R&S SMJ uses files to save all instrument data, i.e. system and user data. The user data includes saved instrument settings, data for the different digital standards, lists for the List mode and the user correction as well as the waveforms for the arbitrary waveform generator.

The files are stored on the hard disk of the instrument. Drive D:\ can be used to save user-defined data; any directory structure can be created on D:\. Some default directories are predefined, but can be changed at any time.

The C:\ drive is a protected system drive. The files on this drive contain data that must not be changed. Therefore, this drive should not be accessed, since reconstruction of the system partition will lead to data loss. To prevent inadvertent deletion or overwriting of system files, this drive is not specified in the file menus. It can be accessed if a protection level (see protection level, Setup menu) is revoked.

Files can be exchanged either via a memory stick or a connected network.

A memory stick is connected to the USB interface and is assigned the E:\ drive.

In the case of a connected network, all network drives that can be accessed are available (see chapter 1, section "[Connecting the R&S SMJ to a Network \(LAN\)](#)", on page 1.30).

The user data can be roughly divided into four data types:

- ◆ Settings
- ◆ Lists
- ◆ Complex modulation and control data
- ◆ Waveforms

The files are accessed in a **File Select** window in the individual menus. Depending on the data type, a file can either be selected or it can be selected and saved:

- ◆ Settings, e.g. the frame setting of the GSM/EDGE standard, can be loaded and saved. In this case, the current setting is saved to the specified file.

Save/Recall Frame...

- ◆ Lists, e.g. user correction lists, can be loaded. They can be generated either externally or internally. For internal generation, a new list must be created in the **File Select** window which will then be edited in the list editor of the individual menu.

User Correction Data...

- ◆ Complex modulation and control data can be loaded. It can be generated either externally or internally. For internal generation, a new list must be created which will then be edited in the data and control list editor. These functions are offered in the **Data List Management** window of the individual modulation menu.

Data/Control List Management...

- ◆ Waveforms are generated externally (e.g. by means of the R&S WinIQSIM program that is supplied together with the optional Baseband Generator R&S SMJ-B10) and can be loaded in the **Arbitrary Waveform Generation** menu.



The files are differentiated according to their extensions; each type of file is assigned a specific file content. The extension is usually of no consequence to the user since access to the files occurs in the individual menus where only the relevant type of file is available. For example, files with frame settings can only be saved and loaded in the **GSM/EDGE** menu.

A button in the individual menu calls up the selection of the **Save, Recall and File Manager** functions. If the file can only be loaded, the **Select or Load and File Manager** selection is available.

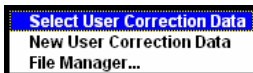

After the **Save/Recall** or **Select/New** selection, a **File Select** window for loading, saving or creating a file is displayed (see the following section "File Select Menu", page 3.38).

After the **File Manager** selection, a menu for managing all files is displayed (see section "File Manager", page 3.40).

All instrument settings are saved and loaded in the **File** menu which is called up by means of the **[File]** key (see chapter 4, section "Storing and Loading Instrument Data - File Key").

## File Select Menu

The **File Select** menu consists of several areas.

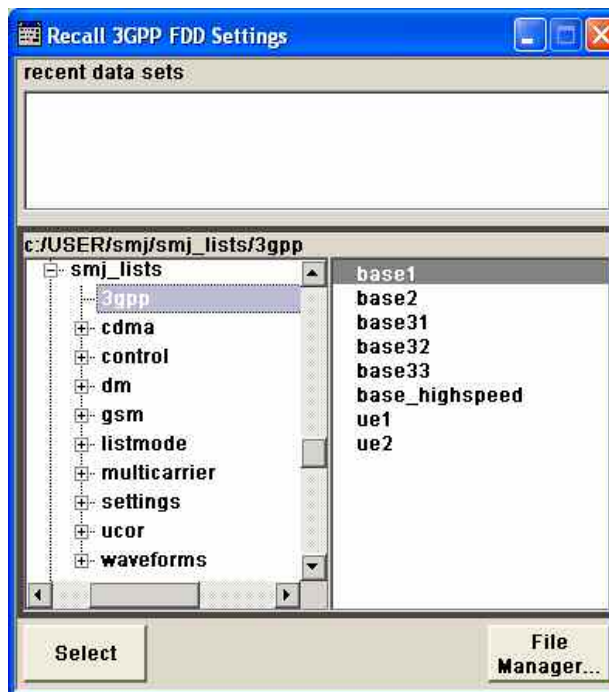
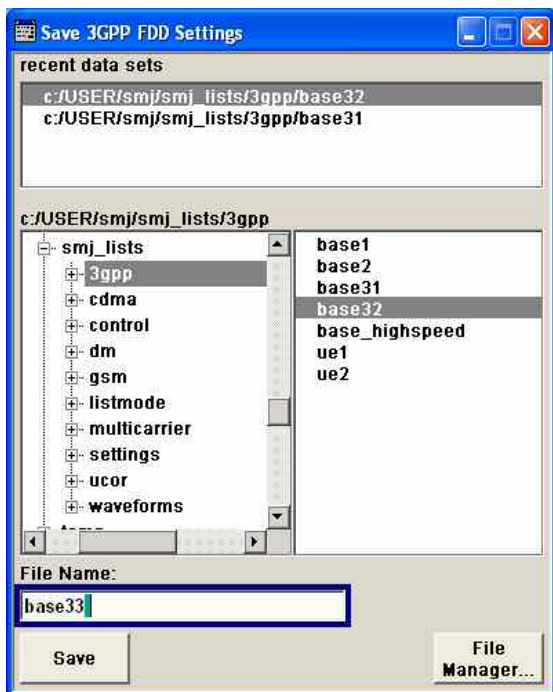

In the upper area, **Recent Data Sets**, the files last used are listed; a maximum of ten files is displayed.

The available drives and directories are displayed on the left side, the files of the selected directory on the right side. The currently selected path is displayed above the windows. Only the relevant files without file extensions are displayed. If the area is opened several times, the path last selected is displayed.

When a file is saved or created, its name is user-selectable; the extension is assigned automatically and cannot be entered.

The file is saved to the selected path.

Operation is similar to the operation of menus with several areas (see section "[Selecting and Exiting a Menu Area - Setting Parameters](#)", on page 3.18):

By using the rotary knob or cursor keys, the area is marked; the entry focus is shifted to this area by clicking the rotary knob or using the Enter key. The rotary knob and the up/down cursor keys will then navigate only within this area. By using the left/right cursor keys, it is possible to switch between the directory tree and the file list. The subdirectories of the selected directory will only be displayed after a short delay to allow quick navigation in the directory tree. Pressing the ESC key again shifts the entry focus up one level. The button for saving or loading the file can be selected and pressed. After the setting, e.g. after selecting the file, the menu will be closed automatically.

◆ Load file:

Mark file and load it by clicking the rotary knob or by pressing the **Select** button/softkey.

◆ Save file:

Enter file name in the **File Name:** field. Mark the directory to which the file is to be saved and then click the **Save** button/softkey.

◆ Create file:

Enter file name in the **File Name:** field. Mark the directory to which the file is to be saved and then click the **Create** button/softkey. The created file is empty; it must be filled with the necessary values in the individual editor.

In addition to the files saved by the user, some menus also offer files containing predefined contents. These files are saved to a specific directory on system drive C:\; for this reason, this directory cannot be chosen from the **File Select** menu. The following example shows the **File Select** menu of the GSM/EDGE digital standard when **Recall Predefined Frames** is selected.

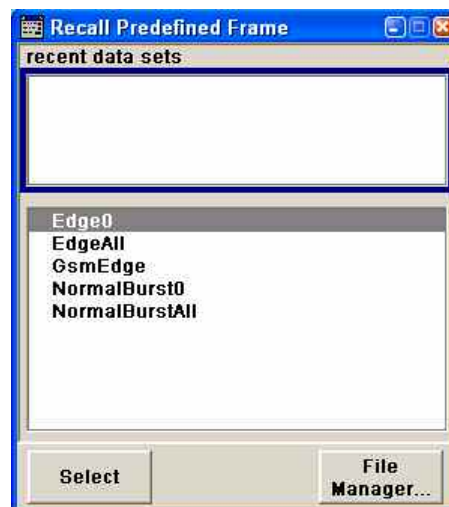

## File Manager

The **File Manager** allows general file management such as copying, shifting, renaming and deleting files as well as generating new directories. Thus, also externally created files, for example waveforms created by using the **R&S WinIQSIM** program, can be saved to the R&S SMJ by copying them from a memory stick or a network to the internal hard disk.

The **File Manager** can be called up in any menu to which files can be saved. Call-up is either at the level of the small selection menu



or via the **File Manager** button in the **File Select** window.



The File Manager can also be called up in the **Save/Recall - Setup-Settings** menu.

In the upper area, **File Type**, the **File Manager** allows the type file selection to be displayed. This can be used to process either all files (all files (\*.\*) selection) or a specific selection of files (e.g. waveforms (\*.wv) selection). The table at the end of this section contains a list of the file types.

The available drives and directories are displayed on the left side, the files of the selected directory on the right side. The currently selected path is displayed above the windows. If the area is opened several times, the path last selected is displayed. Unlike the **File Select** window, the **File Manager** displays the full file names including extensions.

The buttons/softkeys trigger the associated actions such as copying, shifting or deleting the marked files. Plus, a new directory can be created in the level below the marked directory.

Operation is similar to the operation of menus with several areas (see section "[Selecting and Exiting a Menu Area - Setting Parameters](#)", on page 3.18):

By using the rotary knob or cursor keys, the area is marked; the entry focus is shifted to this area by clicking the rotary knob or using the Enter key. The rotary knob and up/down cursor keys will then navigate only within this area. By using the left/right cursor keys, it is possible to switch between the directory tree and the file list. The subdirectories of the selected directory will only be displayed after a short delay to allow quick navigation in the directory tree. Pressing the **ESC** key again shifts the entry focus up one level. The buttons/softkeys can be selected and activated.

- ◆ Shift file:

Mark file and then press the **Cut** button/softkey. Mark the directory to which the file is to be shifted and then click the **Paste** button/softkey. If the target directory already contains a file with the same name, a confirmation query is displayed to confirm overwriting of this file.

- ◆ Copy file:

Mark file and then press the **Copy** button/softkey. Mark the directory to which the file is to be copied and then click the **Paste** button/softkey. If the target directory already contains a file with the same name, a confirmation query is displayed to confirm overwriting of this file.

- ◆ **Rename file:**  
Mark file and then press the **Rename** button/softkey. An entry window for entering the new file name opens. Enter the name and press the Enter key. If a file with the same name already exists, a confirmation query is displayed to confirm overwriting of this file.
- ◆ **Delete file:**  
Mark file and then press the **Delete** button/softkey. Prior to deletion, a confirmation query is displayed which the user must confirm for this file to be deleted.
- ◆ **Create new directory:**  
Mark drive or directory level where the new directory is to be created and then press the **Create New Directory** button/softkey. An entry window for entering the directory name opens. Enter the name and press the Enter key.

Table 3-1 List of file extensions for user files the R&amp;S SMJ assigns automatically

List type	Contents	File suffix
<b>Instrument State</b>		
Instrument State	Instrument settings	*.savrc1
<b>User Correction</b>		
User Correction	User-defined level correction values	*.uco
<b>List Mode</b>		
List	User-defined frequency/level value pairs	*.lsw
<b>Frequency Response Correction</b>		
Frequency Response Correction	User-defined frequency response correction file	*.frc
<b>Arbitrary Waveform Generator</b>		
Waveform Multi segment waveform	ARB ARB multi segment waveforms	*.wv
Multi carrier waveform	ARB multi carrier settings	*.arb_multcarr
Configuration data	Configuration file for creation of multisegment ARB waveforms	*.inf_mswv
Waveform File	Waveform File	*.wav
<b>DM</b>		
Data List	Digital modulation data	*.dm_iqd *.tdm
Control List	Data to control digital modulation	*.dm_iqc
Settings	Digital modulation settings	*.dm
User Standard	Digital modulation user standard	*.dm_stu
User Mapping	Digital modulation user mapping	*.vam
User Filter	Digital modulation user filter	*.vaf
<b>Fading</b>		
Fading	Fading data	*.fad
<b>GSM/EDGE</b>		
Settings	GSM/EDGE settings	*.gsm
Slot	User-defined slot data	*.gsm_slu
Frame	User-defined frame data	*.gsm_fu
Higher symbol rate slot	Higher symbol rate slot	*.gsm_hslu
Higher symbol rate frame	Higher symbol rate frame	*.gsm_hfu

List type	Contents	File suffix
<b>3GPP FDD</b>		
3GPP Settings	Complete setting of the 2GPP (FDD) menu	*.3g
Channel Coding DPCH	Channel coding enhanced DPCH channels (downlink)	*.3g_ccod_dl_s
Channel Coding DPDCH	Channel coding enhanced DPDCH channels (uplink)	*.3g_ccod_ul
<b>CDMA2000</b>		
CDMA2000 Settings	Complete setting of the CDMA2000 menu	*.cdma2k
<b>TD-SCDMA2000</b>		
TD-SCDMA2000 Settings	Complete setting of the TD-SCDMA2000 menu	*.tdscdma
TD-SCDMA Test Model	Test Model for TD-SCDMA2000	*.tdtmd
<b>1xEV-DO</b>		
1xEV-DO Settings	Complete setting of the 1xEV-DO menu	*.evdo
<b>IEEE 802.11 WLAN</b>		
WLAN Settings	Complete setting of the IEEE 802.11 WLAN menu	*.wlan
<b>IEEE 802.11 n WLAN</b>		
WLAN n Settings	Complete setting of the IEEE 802.11n WLAN menu	*.wlann
Beamforming data	Beamforming data	*.bmf
<b>IEEE 802.16 WiMAX</b>		
WiMAX Settings	Complete setting of the IEEE 802.16 WiMAX menu	*.wimax
<b>EUTRA/LTE</b>		
EUTRA/LTE Settings	Complete setting of the EUTRA/LTE menu	*.eutra
IQW Data List	User-defined IQ-File	*.iqw
<b>GPS</b>		
GPS/A-GPS Settings	Complete setting of the GPS/A-GPS menu	*.gps
GPS Almanac Settings	GPS Almanac Settings	*.txt *.alm *.al3
GPS Waypoints File	GPS Waypoints File	*.txt
GPS Generated Almanac File	GPS Generated Almanac File	*rs_al *.rs_yuma
GPS Ionospheric File	GPS Ionospheric File	*.rs_ion
GPS Navigation Data	GPS Navigation Data	*.rs_nav
GPS UTC File	GPS UTC File	*.rs_utc *.rs_acq
<b>FM-Stereo</b>		
FM-Stereo Settings	Complete setting of the FM-Stereo menu	*.fmstereo
FM-Stereo Group Type Settings	FM-Stereo Group Type Settings	*.fm_gt
<b>XM-Radio</b>		
XM-Radio Settings	Complete setting of the XM-Radio menu	*.xmradio
XM-Radio TWTA Data	XM-Radio TWTA Data	*.twta
<b>DVB</b>		
DVB Settings	Complete setting of the DVB menu	*.dvb
DVB Transport Stream	DVB Transport Stream	*.gts *.ts *.trp
<b>DAB/T-DMB</b>		
DAB/T-DMB Settings	Complete setting of the DAB/T-DMB menu	*.dab
DAB ETI Files	DAB ETI Files	*.eti *.xeti

## Manual Remote Control

The R&S SMJ can be remote-controlled from an external PC. This allows convenient operation of the vector signal generator from the desktop although the instrument is integrated in a rack somewhere else.

**Manual remote control** in contrast to **remote control** does not use remote-control commands but separate Windows software which is installed on the external PC. After its start, the remote control software simulates the user interface of the R&S SMJ. The instrument can thus be manually operated from the PC as on the unit itself.

A precondition for manual remote control is a connection between signal generator and PC via a LAN network and the installation of the software on the signal generator and on the PC.

Establishing the connection and installation of the remote-control software on the external PC is described in chapter 1, section "[Connecting the R&S SMJ to a Network \(LAN\)](#)", on page 1.30.

After the connection is established, the current signal generator screen with the block diagram is displayed and the R&S SMJ can be manually remote-controlled from the external PC. The individual functions are operated using the mouse and keyboard. Specific instrument functions can be executed using specific key combinations on the keyboard. Front-panel keys which are not directly available on the keyboard can be substituted by key combinations or by the front panel key emulation panel (see next section).

When the connection is set up with **Remote Control Desktop**, the device firmware of the R&S SMJ is disabled. Direct control on the R&S SMJ is not possible while manual remote-control is active. The access of an external PC is indicated by the logon screen of Windows XP Embedded which identifies the accessing user.



When the connection is set up with **Ultr@VNC**, direct control on the R&S SMJ is possible while manual remote-control is established, it can be performed alternately with the manual remote control.

For return to direct operation on the R&S SMJ, the connection must be cut. After cutting the connection, it is still enabled and can be established again any time. The connection is disabled only after deactivation of the program (see chapter 1, section "[Manual Remote Control via an External Controller](#)", on page 1.39).

## Legend of Front-Panel Controls

The following table lists all key functions available on the front panel. Key combinations used on the PC keyboard to trigger key functions on the instrument front panel are also described. Keyboard labels are described in alphabetical order.

In addition, a front panel key emulation and an on-screen keyboard can be used for manual operation by mouse only (see below).

Front-panel key	Key of PC keyboard	Function
	Tab key (towards the right) Shift + Tab (towards the left)	Sets the cursor with the rotary knob.
	Enter	Pressing the rotary knob confirms an entry; it has the same function as the ENTER key.
	Arrow keys	Moves the cursor.
*1 / dB(m)	ALT + F12	Confirms entries in the base unit and values without a unit. Selects dBm for the RF level and dB for level offset and level step width.
. / *...#	. / *...#	Enters a period/decimal point. Enters a special character.
+/- / A↔a	- / (shift+) a—z	Enters the sign. Switches between upper-case and lower-case letters.
0-9 / a...z	CTRL+ 0-9 / a...zCTRL	Enters the number/letter.
BACKSPACE	Backspace	Clears the last entry (number, sign or decimal point)
CLOSE	CTRL + G	Closes an active menu.
DIAGRAM	CTRL+ D	Sets the cursor on the block diagram and hides all menus.
ENTER	Enter	Terminates an entry.
ESC	ESC	Selects the next higher menu/selection level. When the editing mode is exited with ESC, the previous value is restored.
FILE	CTRL + S (storage under Windows)	Activates the menu for storing instrument settings.
FREQ	CTRL+ F	Activates the frequency entry.
G/n / dBµV	ALT + F9	Selects the unit Giga/Nano, dBµV for the RF level and dBu for the LF level.
HCOPY	CTRL+ Y	Opens the menu for configuring and starting a hardcopy.
HELP	F1	Opens/closes context-sensitive help.
HIDE	CTRL+ H	Minimizes the active menu. Pressing the respective button in the Winbar opens the menu again.
INFO	CTRL + I	Opens/closes the info window
INSERT	Ins	Activates the insert mode.
k/m / µV	ALT + F11	Selects the units Kilo/Milli and µV for RF levels.
LEVEL	CTRL + L	Activates the level entry.



Front-panel key	Key of PC keyboard	Function
LOCAL	CTRL + Q	Switches the instrument from remote control to manual control.
M/ $\mu$ / $\mu$ V	ALT + F10	Selects the units Mega/Micro and $\mu$ V for RF levels.
MENU	CTRL + M	Calls the menu selection list.
MOD ON/OFF	CTRL + O	Switches modulation on/off. MOD OFF is indicated in the status line.
ON/OFF TOGGLE	CTRL + T	Switches a block or parameter on/off.  Toggles between the different possibilities of setting a selection parameter.
PRESET	CTRL + P	Restores a defined basic instrument setup.
REARR	CTRL + A	Arranges open menus automatically.
RECALCULATE	CTRL + C	Starts recalculation of the signal.
RF ON/OFF	CTRL + R	Switches the RF output signal on/off. RF OFF is indicated in the status line.
SETUP	CTRL + E	Opens the setup menu for general instrument settings.
Softkey 1 – 8	CTRL + F1 – F8	Triggers the function assigned to the softkey.
WINBAR	CTRL + W	Displays the Winbar in the foreground/background.

## Front Panel Key Emulation

The R&S SMJ provides a front panel key emulation to enable execution of the front panel key functions by mouse e.g. for manual remote control. The emulation is called by a right mouse click. The front panel key functions are executed by a mouse click on the associated button.



## On-screen Keyboard

In addition, the Windows XP operating system provides a keyboard emulation that can be used for system settings if no external keyboard but a mouse is available. It is called in the **START - Programs - Accessories - Accessibility** menu, selection **On-Screen Keyboard**.



## Contents - Chapter 4 "Instrument Functions"

<b>Instrument Functions .....</b>	<b>4.1</b>
Overview of Instrument Functions.....	4.1
<b>General Instrument Settings .....</b>	<b>4.4</b>
Overview of General Instrument Settings .....	4.4
Default Instrument Settings - Preset Key .....	4.4
General Configuration of Instrument - Setup Key .....	4.5
Internal Adjustments - Setup-System.....	4.6
Hardware Config... - Setup-System.....	4.8
Gui Update... - Setup/System.....	4.9
Software / Options... - Setup/System .....	4.9
Install SW-Option... - Setup/System.....	4.10
Update - Setup-System .....	4.10
Test Point... - Setup-Test .....	4.11
Selftest - Setup-Test.....	4.12
Check Front Panel - Setup-Test.....	4.13
Global Trigger/Clock/External Input Settings - Setup-Environment .	4.13
Display/Keyboard Settings - Setup-Environment .....	4.16
User Marker / AUX I/O - Setup-Environment-Global...Settings .....	4.17
GPIB/Ethernet - Setup-Remote.....	4.20
LXI Status - Setup-Remote .....	4.21
Protection - Setup-Protection .....	4.22
Security - Setup -Protection .....	4.23
Save Recall - Setup-Setting .....	4.24
Factory Preset - Setup-Setting .....	4.24
Help - Setup-Help.....	4.25
Switching to Manual Control - Local Key .....	4.25
Generating a Hardcopy of Display - Hcopy Key.....	4.25
Messages - Info Key.....	4.25
Help System - Help Key .....	4.26
Storing and Loading Instrument Data - File Key .....	4.28
File Menu.....	4.29
Storing Instrument Settings - File .....	4.29
Loading Instrument Settings - File.....	4.31
File Manager - File .....	4.33

<b>Graphical Display - Graphics .....</b>	<b>4.35</b>
Graphical Display of Signal Characteristics .....	4.35
Graphics Settings Menu .....	4.36
Softkey Bar of Graphics Window.....	4.38
Signal Displays - Graphics .....	4.41
I/Q Diagram - Graphics .....	4.41
Vector Diagram - Graphics.....	4.42
Constellation Diagram - Graphics .....	4.43
Eye Diagram - Graphics .....	4.44
CCDF Display - Graphics .....	4.45
Power Spectrum - Graphics .....	4.46
<b>Bit and Block Error Rate Measurements - BERT Block.....</b>	<b>4.47</b>
Introduction - Bit and Block Error Rate Measurements.....	4.47
Bit Error Rate Menu.....	4.52
Block Error Rate Menu .....	4.63
<b>RF Signal and Analog Mod - A Mod-RF A .....</b>	<b>4.70</b>
Overview of RF Signal and Analog Modulations.....	4.70
RF Frequency and Phase - Frequency - Phase.....	4.72
Frequency - Phase Menu .....	4.73
Phase Continuous Frequency Setting.....	4.75
RF Reference Frequency - Reference Oscillator .....	4.78
Reference Oscillator Menu.....	4.78
RF Level - Level - EMF .....	4.80
Level - EMF Menu .....	4.81
Automatic Level Control - ALC .....	4.84
Automatic Level Control Menu .....	4.84
Power Sensors .....	4.86
NRP-Z Power Viewer Menu .....	4.86
User Correction .....	4.92
User Correction Menu .....	4.92
Filling the Correction List automatically.....	4.98
Filling the Correction List with Power Sensor Measurement Data...	4.99
Overvoltage Protection.....	4.100
List Mode - List .....	4.101
Filling the List Mode Data automatically.....	4.109

Sweep Mode.....	4.110
Frequency Sweep Menu .....	4.110
Level Sweep Menu.....	4.116
LF Frequency Sweep Menu .....	4.120
LF Generator and LF Output - LF Output.....	4.125
LF Output Menu.....	4.125
Analog Modulations .....	4.126
Modulation Sources.....	4.126
Simultaneous Operation of Several Modulations or Other Operating Modes .....	4.127
Amplitude Modulation - AM .....	4.128
Amplitude Modulation Menu.....	4.128
Broadband Amplitude Modulation - BB-AM .....	4.131
Broadband Amplitude Modulation Menu .....	4.131
Pulse Modulation .....	4.133
Pulse Modulation Menu .....	4.133
Frequency Modulation - FM .....	4.135
Frequency Modulation Menu.....	4.135
Phase Modulation - PhiM .....	4.139
Phase Modulation Menu.....	4.139
<b>I/Q Modulation .....</b>	<b>4.143</b>
Introduction - I/Q Modulation .....	4.143
I/Q Modulator - I/Q MOD Function Block .....	4.144
I/Q Settings Menu.....	4.144
<b>Impairment of Digital I/Q Signal and Noise Generator - AWGN-IMP Block .....</b>	<b>4.153</b>
Introduction - Impairments.....	4.153
Impairment Settings Menu .....	4.154
Introduction - AWGN - Noise Generator .....	4.159
AWGN Settings Menu .....	4.160
Output of the Baseband Signal - I/Q Out .....	4.169
Digital I/Q Output.....	4.174
I/Q Level - Info.....	4.179
Baseband Signal Level.....	4.179
Baseband Signal Level Measurement .....	4.180

<b>Baseband Signal - Baseband.....</b>	<b>4.182</b>
Introduction - Baseband Signal .....	4.182
Signal Routing and Frequency Shifting .....	4.183
Data and Signal Sources in Baseband .....	4.186
Internal PRBS Data and Data Patterns .....	4.186
Internal Modulation Data from Lists.....	4.187
External Synchronous Modulation Data .....	4.188
Clock Signals.....	4.189
Synchronizing Data Signals and Clock Signals .....	4.190
Control Signals .....	4.193
Trigger Signals .....	4.194
Marker Output Signals.....	4.195
<b>Digital Modulation - Custom Digital Modulation .....</b>	<b>4.196</b>
Introduction - Custom Digital Modulation .....	4.196
Modulation Types - Custom Digital Mod .....	4.196
Coding - Custom Digital Mod .....	4.200
Baseband Filter - Custom Digital Mod .....	4.203
Conflicting Settings - Custom Digital Mod .....	4.205
Custom Digital Mod Menu .....	4.206
Custom Digital Modulation Main Menu .....	4.207
List Management - Digital Modulation Menu.....	4.217
Data List Editor - Digital Modulation.....	4.220
Control and Marker List Editor - Digital Modulation.....	4.222
Power Ramp Control - Digital Modulation Menu .....	4.226
Trigger/Marker/Clock - Custom Digital Modulation Menu .....	4.228
<b>Arbitrary Waveform Generator ARB.....</b>	<b>4.235</b>
Introduction – ARB .....	4.235
ARB Menu .....	4.238
ARB MOD Main Menu .....	4.239
Trigger/Marker/Clock - ARB MOD Menu.....	4.248
Sine Test Signals - ARB MOD Menu .....	4.255
Create Multi Segment Waveforms - ARB Menu.....	4.257
Typical Applications for Multi Segment Waveforms - ARB Menu ..	4.262
Create Multi Carrier Waveforms - ARB Menu .....	4.263
ARB Multi Carrier Submenu .....	4.263
Typical Applications for Multi Carrier Waveforms - ARB Menu.....	4.271

# 4 Instrument Functions

## Overview of Instrument Functions

This chapter explains the functions of the vector signal generator and the options available in the setting menus. The associated IEC/IEEE-bus command is specified for each parameter (where applicable).

The description begins with the general instrument settings which do not directly affect signal generation. The majority of these settings can be accessed by means of front-panel softkey menus and not by means of function block menus. One exception is, for example, the signal graphics which are called up in the **Graphics** block.

The signal generation functions are then described, beginning with the RF section functions which affect the RF signal and the analog modulations and which are compiled in the **RF/A Mod** block of the block diagram.

This is followed by an explanation of all functions which are in the signal flow prior to being fed into the RF block and which do not affect the internal generation of a baseband signal - I/Q modulation, noise generation and impairment of the digital signal. These functions are accessed by means of the function blocks **I/Q Mod** and **AWGN/IMP**.

The remaining (and largest) part of the chapter describes the functions used for the internal generation of the signals in the baseband (these functions are provided in the **Baseband** block).

The general instrument settings include various functions, such as:

- Setting a defined basic setup using the **[PRESET]** key  
(section "[Default Instrument Settings - Preset Key](#)" on page 4.4")
- Switching from remote control to manual control using the **[LOCAL]** key  
(section "[Switching to Manual Control - Local Key](#)" on page 4.25")
- Configuring the generator and its interfaces in the **Setup** menu - e.g. setting the IEC/IEEE-bus address, starting an adjustment, querying instrument data  
(section "[General Configuration of Instrument - Setup Key](#)", page 4.5)
- Generating a hardcopy of the display using the **[HCOPY]** key  
(section "[Generating a Hardcopy of Display - Hcopy Key](#)", page 4.25)
- Calling up the online help using the **[HELP]** key  
(section "[Help System - Help Key](#)", page 4.26)
- Querying messages using the **[INFO]** key  
(section "[Messages - Info Key](#)", page 4.25)
- Loading and storing complete instrument settings in the **File** menu  
(section "[Storing and Loading Instrument Data - File Key](#)", page 4.28)
- Calling up the baseband signal graphics in the **Graphics** function block  
(section "[Graphical Display - Graphics](#)", page 4.35)

The integrated bit error rate and block error tester is configured and activated in the **BERT** function block:

- Bit error rate and block error measurement  
(section '[Bit and Block Error Rate Measurements - BERT Block](#)' on page 4.47)

The RF signal is configured and the analog modulations activated in the **RF/A Mod** function block:

- CW mode  
(section "[Overview of RF Signal and Analog Modulation](#)", page 4.70)
- List mode  
(section "[List Mode - List](#)", page 4.101)
- Sweep mode  
(section "[Sweep Mode](#)", page 4.110)
- Analog modulations  
(section "[Analog Modulations](#)", page 4.126)

In the I/Q-Mod function block, I/Q modulation is possible with external analog signals and internally generated baseband signals.

Noise can be added to the baseband signal and the baseband signal can be impaired before input into the I/Q modulator. It is therefore possible to output a baseband signal with impairments via the I/Q-OUT outputs (**Impairment/AWGN** function block). Impairment is also possible during I/Q modulation (**I/Q Mod** function block).

- I/Q modulator  
(section "[I/Q Modulator - I/Q MOD Function Block](#)", page 4.144)
- Impairing the signal prior to input into the I/Q modulator  
(section "[Introduction - Impairments](#)", page 4.153)
- Adding noise  
(section "[Introduction - AWGN](#)", page 4.159)

The baseband signal is available at the I/O outputs.

- Output of the baseband signal  
(section "[Output of the Baseband Signal - I/Q Out](#)", page 4.169)

The R&S Vector Signal Generator offers various possibilities for generating digital modulation signals in compliance with the definitions of digital standards or with characteristics which can to a large extent be freely defined. The range of software options for this is being extended continuously.

- Baseband signals - Introduction  
(section "[Baseband Signal - Baseband](#)", page 4.93)
- Digital modulation  
(section "[Digital Modulation - Custom Digital Modulation](#)", page 4.105)
- Arbitrary waveform generator ARB  
(section "[Arbitrary Waveform Generator ARB](#)", page 4.129)
- Multi Carrier CW signals  
(section "[Multi Carrier Continuous Wave](#)")
- Digital standard GSM/EDGE  
(section "[Digital Standard GSM/EDGE](#)")
- Digital standard 3GPP FDD (WCDMA)  
(section "[Digital Standard 3GPP FDD \(WCDMA\)](#)")



- Digital standard CDMA2000®  
(section "[Digital Standard CDMA2000®](#)")
- Digital standard TD-SCDMA  
(section "[Digital Standard TD-SCDMA](#)")
- Digital standard 1xEV-DO  
(section "[Digital Standard 1xEV-DO](#)")
- Digital standard IEEE 802.11 (a/b/g) (WLAN)  
(section "[Digital Standard IEEE 802.11 \(a/b/g\) \(WLAN\)](#)")
- Digital standard IEEE 802.11n (WLAN-N)  
(section "[Digital Standard IEEE 802.11n \(WLAN-N\)](#)")
- Digital standard IEEE 802.16 (WiMAX)  
(section "[Digital Standard IEEE 802.16 \(WiMAX\)](#)")
- Digital Standard EUTRA  
(section "[Digital Standard EUTRA](#)")
- Digital standard GPS/A-GPS  
(section "[Digital Standard GPS](#)")
- Digital Standard XM Radio  
(section "[Digital Standard XM Radio](#)")
- Digital Standard FM Stereo  
(section "[Digital Standard FM Stereo](#)")
- Digital Standard DVB-H  
(section "[Digital Standard DVB-H](#)")
- Digital Standard DAB / T-DMB  
(section "[Digital Standard DVB / T-DMB](#)")

# General Instrument Settings

## Overview of General Instrument Settings

The section "General Instrument Settings" describes the settings which do not directly affect signal generation.

Most of these settings can only be accessed by means of menus which are opened using keys. This does not apply to the graphical representation of output signals which is activated in the **Graphics** function block, or settings which can additionally be called up in the menus of the function blocks, e.g. input configuration which is possible in the **Setup** menu and in almost every menu of the **Baseband** function block.

The general instrument settings therefore affect various functions, such as storing instrument settings or setting the IEC/IEEE-bus address in the menu of the **SETUP** key. The order in which the descriptions are given corresponds to the layout of the keys on the front panel of the Vector Signal Generator (from top left to bottom right)

## Default Instrument Settings - Preset Key

The **PRESET** key calls up a defined instrument setup. All parameters and switching states are preset (also those of inactive operating modes). The default instrument settings provide a reproducible initial basis for all other settings. However, functions that concern the integration of the instrument into a measurement setup are not changed, e.g. IEC/IEEE bus address or reference oscillator source settings.

Remote-control command:

\*RST

In addition, only those settings associated with the menu can be reset directly in the individual menus, e.g. all digital modulation settings in the **Custom Digital Mod** menu. These settings are identical to those which are called up using the **PRESET** key.

When the instrument is switched on, it is not the preset state that is active, but rather the instrument state that was set before the instrument was switched on.

User-defined instrument states can be stored and called up in the **File** menu.

The following table gives an overview of the presets for the most important generator settings. The other presets can be found in the preset tables of the individual menus and the information accompanying the IEC/IEEE-bus commands.

The list below the table shows the settings that are not affected by the **PRESET** key.

Table 4-1 Preset state - important generator settings

RF frequency	1 GHz
RF level	RF output switched off
Offsets	0
Modulations	Switched off
Uninterrupted level setting	Switch off; level attenuator mode: AUTO
Internal level control	Level ALC: AUTO
User correction	Level Ucor: OFF
LF output	Switched off
Sweep	Switched off
List mode	Switched off

Settings that are not affected by the **PRESET** key

- Reference frequency settings (Ref Oscillator menu)
- Power on settings (Level/EMF menu)
- Network settings (Setup menu)
- IEC/IEEE-bus address (Setup menu)
- Password and settings protected by passwords (Setup menu)
- Start/Stop Gui Update (Setup menu)
- Display and keyboard settings (Setup menu).

## General Configuration of Instrument - Setup Key

The **SETUP** key opens the **System** menu used to set general instrument parameters and the **Environment** menu used to configure the instrument interfaces.

Most submenus of this key can be accessed only via the **SETUP** key or the menu tree (**MENU** key), with the following exceptions:

- The **Reference Oscillator** submenu can also be called up in the **RF / A Mod** block and is therefore described in the section on this block (see section "[RF Reference Frequency - Reference Oscillator](#)", page 4.78).
- The **Save/Recall** submenu can also be called up with the **FILE** key and is therefore described in the section on this key (see section "[Storing and Loading Instrument Data - File Key](#)", page 4.28).
- The **Global Trigger/Clock/ External Inputs** submenu (see section "[Global Trigger/Clock/External Input Settings - Setup-Environment](#)", page 4.13) is also available in all modulation menus of the **Baseband** function block where it can be called up with the **Global Trigger/Clock Settings** button in the trigger/marker and clock submenus.



## Internal Adjustments - Setup-System

The R&S Vector Signal Generator is extremely accurate thanks to the integrated procedures for adjustments.

All internal adjustments for which no external measuring equipment is needed can be started in the **Internal Adjustments...** menu. The adjustments with external measuring equipment are described in the Service Manual (on CD ROM, supplied with the instrument).

Adjustment is recommended if the temperature range in which the instrument is operated changes, or prior to all applications which require maximum level and frequency accuracy.

During adjustment a bar indicates the status of progress. If an error occurs, adjustment is terminated and an error message is output in the info line.

---

### Caution:

*Make sure that the instrument is warm before performing adjustments. The warm-up time is 30 minutes.*

---

The **Internal Adjustments** menu is opened up using the **SETUP** or **MENU** key under **System**. The adjustments offered also depend on the installed options, e.g. FM Modulator.

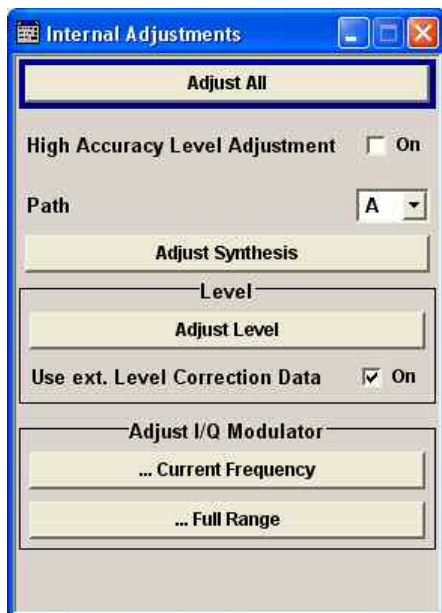

### Adjust All - Setup Internal Adjustments

Starts all internal adjustments for which no external measuring equipment is needed. The adjustments with external measuring equipment are described in the Service Manual (supplied).

Remote-control command:

CAL:ALL?

<b>High Accuracy Level Adjustment - Setup Internal Adjustments</b>	Enables/disables level adjustment with high accuracy. Remote-control command: CAL:LEV:HACC ON
<b>Path - Setup Internal Adjustments</b>	Indicates the path for which the following adjustments are to be performed. Remote-control command: n.a.
<b>Adjust Synthesis - Setup Internal Adjustments</b>	Performs all adjustments which affect the frequency. This includes adjustment of option R&S SMJ-B20, FM/PhiM Modulator. Remote-control command: CAL1:FREQ:MEAS?
<b>Adjust Level - Setup Internal Adjustments</b>	Performs all adjustments which affect the level. Remote-control command: CAL:LEV:MEAS?
<b>Use ext. Level Correction Data - Setup Internal Adjustments</b>	Switch on or off use of external level correction data (see service manual, chapter 2, "Adjustment"). This switch can be used in case of corrupt external level correction data. Remote-control command: CAL:LEV:STAT ON
<b>Adjust I/Q Modulator Current Frequency - Setup Internal Adjustments</b>	Starts the adjustment for the I/Q modulator for the currently set frequency, I/Q swap, and baseband gain. The I/Q modulator is adjusted with respect to carrier leakage, I/Q imbalance and quadrature. Adjustment for only the set frequency is considerably faster than adjustment across the entire frequency range. This is possible with ... <b>Full Range.</b> Remote-control command: CAL1:IQM:LOC
<b>Adjust I/Q Modulator Full Range- Setup Internal Adjustments</b>	Starts the adjustment for the I/Q modulator for the entire frequency range. The I/Q modulator is adjusted with respect to carrier leakage, I/Q imbalance and quadrature. Remote-control command: CAL1:IQM:FULL?

## Hardware Config... - Setup-System

In the **Hardware Config** menu, the installed assemblies together with their variants and revision states can be displayed for servicing purposes.

The **Hardware Config** menu is opened using the **SETUP** or **MENU** key under **System**.

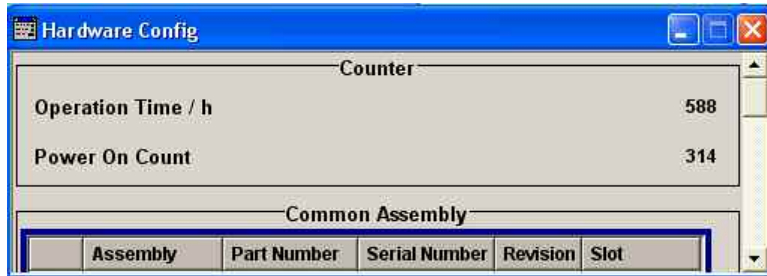

Section **Counter** in the upper part of the menu shows the **Operation Time** (in hours) and the number of power-on (**Power On Counter**).

Remote-control command:

```
DIAG:INFO:OTIM?
```

```
Response: "100023"
```

```
DIAG:INFO:POC?
```

```
Response: "123"
```

A table below lists the installed assemblies. It is divided into the sections **Common Assembly**, **RF Assembly** and **Baseband Assembly**.

<b>Assembly</b>	Assembly name
<b>Part Number</b>	Part Number of assembly
<b>Serial Number</b>	Serial Number of assembly
<b>Revision</b>	Revision state of assembly
<b>At slot</b>	Indicates whether the assembly is connected to the serial bus or PCI bus

Remote-control command:

```
DIAG:BGIN? "MBRD"
```

```
Response:
```

```
"MBRD 1141.3501.02 1.5.3 100023"
```

## Gui Update... - Setup/System

The **Start/Stop Gui Update** menu... provides the possibility to switch off update of the displayed parameters in order to increase speed for certain settings.

The indicated values are not updated and may therefore differ from the intern, used values.

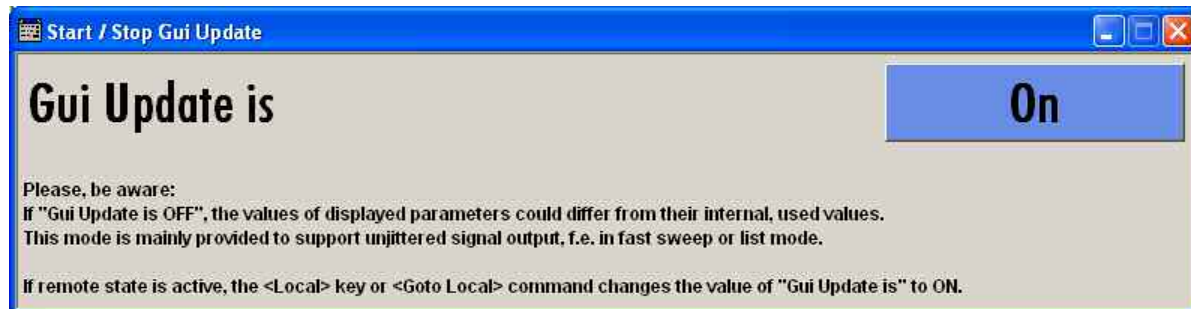

Remote-control command:

```
SYST:DISP:UPD OFF
```

## Software / Options... - Setup/System

The **Software / Options...** shows the firmware version of the instrument software as well as all installed hardware and software options.

---

### Note:

*Software options purchased at a later stage can be activated with a keycode. The activation code is supplied with the software option. How to install options is described in Chapter 4 of the Service Manual (supplied with the instrument).*

*The installation of hardware options purchased at a later stage is also described in Chapter 4 of the Service Manual (supplied with the instrument). Most hardware options need to be installed at an authorized Rohde&Schwarz service shop.*

---

The **Software / Options** menu is opened using the **SETUP** or **MENU** key under **System**.

Remote-control commands:

```
*OPT?
```

Response:

```
"SMJ-B106/B116, SMJ-B203, SMJ-B10, SMJ-B10, SMJ-B13, SMJ-B13, ...."
```

```
*IDN?
```

Response:

```
"Rohde&Schwarz, SMJ1200A, 1403.4542K02/123456, 1.00.0.0 (Release) "
```

The **Firmware** section of the menu shows the firmware version and the version of the software platform.

The tables in the sections **Hardware**, **Software** and **WinIQSIM** list the installed hardware and software options.

<b>Option</b>	Short name of option
<b>Designation</b>	Name of Option
<b>Licenses</b>	Number of licenses
<b>Expiration Date</b>	Expiration date of option For regular options, Permanent is indicated in this column. Some options are available as trial versions. This column shows their expiration date. After this date, the option is no longer available on the instrument.

Section **Loaded Modules** is provided for service purposes. It lists all loaded software modules with their versions and offers a short description of each module.

## Install SW-Option... - Setup/System

Newly purchased software options are enabled in the **Install SW-Options** menu.... They are ready to operate after they are enabled by means of a key code supplied with the option.



Only if the R&S Vector Signal Generator is equipped with an older firmware version, a firmware update prior to enabling the software option may be required. The information on the valid firmware versions for the purchased software option is provided together with the option. The firmware update is described in the service manual instrument, chapter 4 (on CD ROM, supplied with the instrument).

## Update - Setup-System

After a firmware update it is occasionally required to also update the PCI-FPGA. This is enabled in the **Update...** menu".

At the first start of the new firmware, a message appears during the boot process if a PCI-FPGA update is required, also. A PCI-FPGA update is by pressing the **PCI-FPGA** button.

**NOTICE** *To avoid impairment of instrument functions, the update of the PCI-FPGA must not be cancelled and the instrument must not be switched off during this update.*

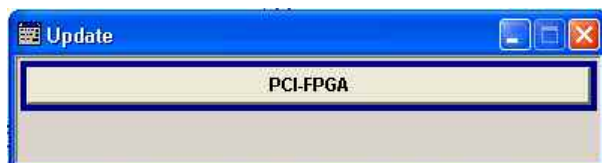



## Test Point... - Setup-Test

The **Test Point...** menu provides access to the test points available in the instrument. When activated, the voltage of the selected test point is measured and displayed. A detailed description of the test points can be found in Chapter 3 of the Service Manual (supplied with the instrument).

The **Test Point...** menu is opened using the **[SETUP]** or **[MENU]** key under **System**.

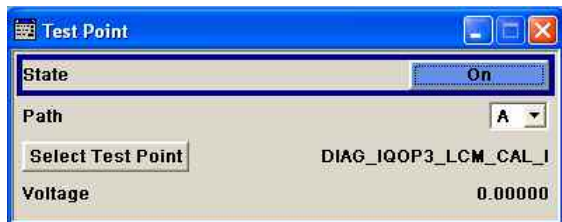

### State Test Point - Setup

Activates the measurement of the voltage at the selected test point.

Remote-control command:

```
DIAG1:MEAS:POIN? 'DIAG_IQOP3_LCM_CAL_I'
```

Response: 2

### Path Test Point - Setup

Selects the path along which the test point is measured. Selection is only possible with two-path instruments.

Remote-control command: n.a.

(The path is selected using the suffix under DIAGnostic)

### Select Test Point - Setup

Calls the submenu for selecting the test point. The currently selected test point is shown next to the button.



Remote-control commands:

```
DIAG1:POIN:CAT? (Command lists all test points)
```

```
DIAG1:MEAS:POIN? 'DIAG_IQOP3_LCM_CAL_I'
```

(With remote control, voltage measurement starts as soon as the test point is selected)

### Voltage Test Point - Setup

Displays the measured voltage measurement at the selected test point.

Remote-control command:

```
DIAG1:MEAS:POIN? 'DIAG_IQOP3_LCM_CAL_I'
```

Response: 2

## Selftest - Setup-Test

A selftest is provided for service purposes. The selftest is a protected test procedure, which can be accessed if protection level 1 is disabled. The protection dialog is called in the **Setup** menu (see [Protection - Setup-Protection](#), on page 4.22).

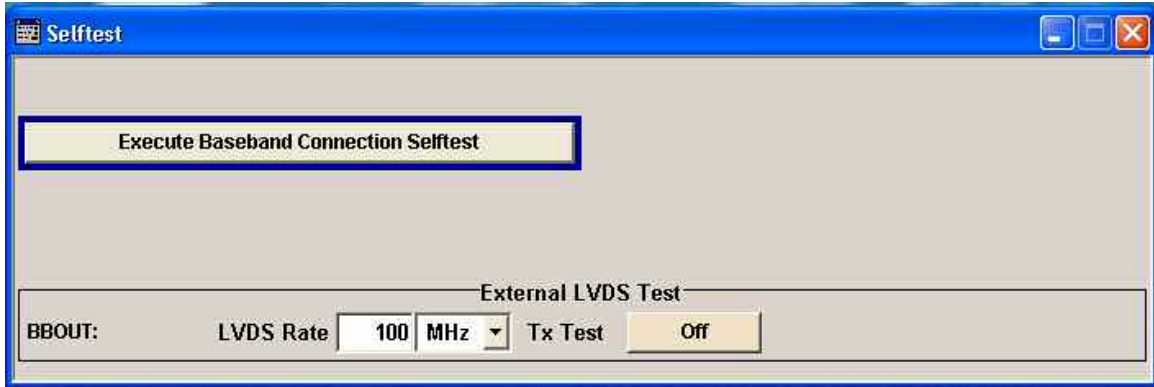

### Execute Baseband Connection Selftest - Setup System Selftest

Performs a connection test on each of the internal digital baseband links. This implies all installed options as baseband inputs, motherboard, universal coding generators, fading simulators, and baseband outputs. The result (succeeded or failed) is displayed in the status field next to the **Execute Baseband Connection Selftest** button.

Remote-control command:  
`TEST:BB:CONNECTION?`

Response: Succeeded, Failed

### BBOU LVDS Rate - Setup System Selftest

Sets the interface speed.

The **External LVDS Test** is used to check the correct data transmission of the digital baseband outputs (BBOU).

An external cable connection is needed to perform this test successfully. An output must be connected to an input with the digital I/Q cable. Always an input/output pair is tested together. The input and the output can be on the same instrument, or alternatively on two different instruments. Given an arbitrary cable connection, the appropriate Tx test can be activated with different interface speeds (LVDS rate).

On the connected input, this test sequence is received and can be compared with the expected test signal.

Remote-control command:  
`TEST:BBOut:LRATE 90MHZ`

### Tx Test - Setup System Selftest

Activates the transmission of a known pseudo-random sequence (On).

Remote-control command:  
`TEST:BBOut:TTEST:STATE ON | OFF`

## Check Front Panel - Setup-Test

The **Check Front Panel** menu.. is used to check whether the front panel keys are functioning correctly. The menu displays all the front panel keys arranged in the same way as on the front panel. The respective function is executed by pressing the associated key.

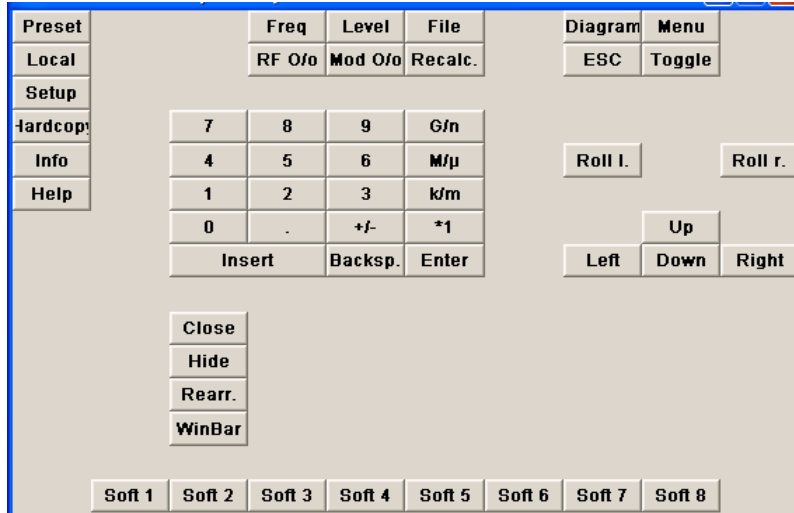

## Global Trigger/Clock/External Input Settings - Setup-Environment

The **Global Trigger/Clock/External Inputs** menu can be opened using the **SETUP** or **MENU** key under the **Environment** menu as well as in all clock and trigger menus of the **Baseband** function block.

This menu is used to determine the physical characteristics of the input connectors for trigger, clock and control signals of the baseband and RF section. The user inputs/outputs (BNC connector and pins of the AUX I/O connector) are assigned in the menu User Marker AUX I/O (see [User Marker / AUX I/O - Setup-Environment-Global...Settings](#), on page 4.17).

A common trigger threshold and input impedance is effective for all trigger and control signal inputs. The settings influence the digital modulations, the generation of waveforms or multi carrier signals, and all digital standards. Irrespective of this, a common threshold and input impedance is effective for the serial and parallel data input. These data sources are available for digital modulation (**Custom Digital Modulation**).

The instrument trigger setting influences all sweeps and is effective in the List mode (Instrument Trigger).

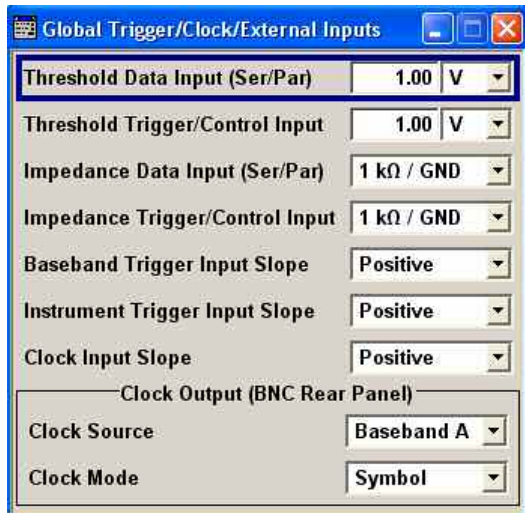

### Threshold Data Input - Global Settings

Sets the high/low threshold in volts for the serial and parallel data input.

The serial data is input at the DATA connector on the front of the instrument. The parallel data is input via the AUX I/O interface at the rear of the instrument (DATA pins).

Remote-control command:  
`SOUR:INP:DATA:THR 1.0`

### Threshold Trigger/Control Input - Global Settings

Sets the high/low threshold in volts for the trigger and control signal inputs of the baseband section.

The setting affects the TRIGGER 1 and 2 inputs (BNC connectors at the front and rear of the instrument) and the CW, BURST and LEV\_ATT inputs (AUX I/O interface at the rear of the instrument).

Remote-control command:  
`SOUR:INP:TRIG:LEV 1.0`

### Impedance Data Input - Global Settings

Selects the input impedance for the serial and parallel data inputs. 50 Ohm/GND should be selected for high clock rates.

The serial data is input at the DATA connector on the front of the instrument. The parallel data is input via the AUX I/O interface at the rear of the instrument (DATA pins).

Remote-control command:  
`SOUR:INP:DATA:IMP G50`

**Impedance Trigger/Control Input - Global Settings** Selects the input impedance for the external trigger and control signal inputs. 50 Ohm/GND should be selected for high clock rates.

The setting affects the TRIGGER 1 and 2 inputs (BNC connectors at the front and rear of the instrument) and the CW, BURST and LEV\_ATT inputs (AUX I/O interface at the rear of the instrument).

Remote-control command:

```
SOUR:INP:TRIG:IMP G1K
```

**Baseband Trigger Input Slope - Global Settings** Selects the polarity of the active slope of an externally applied trigger signal at the BNC connector TRIGGER 1/2.

Remote-control command:

```
SOUR:INP:TRIG:BBAN:SLOP POS
```

**Instrument Trigger Input Slope - Global Settings** Sets the polarity of the active slope of an applied instrument trigger. This setting affects the INST TRIG input (BNC connector at the rear of the instrument and the INST TRIG B input of the AUX I/O interface at the rear of the instrument).

Remote-control command:

```
SOUR:INP:TRIG:SLOP POS
```

**Clock Input Slope - Global Settings** Sets the polarity of the active slope of an externally applied bit clock pulse or symbol clock pulse.

This setting affects the CLOCK input (BNC connector at the front of the instrument).

Remote-control command:

```
CLOC:INP:SLOP POS
```

The polarity of the clock output at the rear panel is set in the **Clock Output (BNC Rear Panel)** section.

**Clock Output Mode - Global Settings** Sets the output of bit or symbol clock pulses at the CLOCK OUT connector at the rear panel.

Remote-control command:

```
CLOC:OUTP:MODE SYMB
```

## Display/Keyboard Settings - Setup-Environment

In the **Display/Keyboard Settings** menu the power-save mode and external keyboard settings are made. It is opened using the **[SETUP]** or **[MENU]** key under **Environment**.



### Screen Saver Active - Setup

Activates/deactivates the screen-save mode of the display.

With the screen-save mode activated the display including backlight is completely switched off after the elapse of the **Wait Time** when no entries via front panel, external mouse or external keyboard are made.

This mode is recommended for preserving the display especially if the instrument is exclusively operated via remote control.

Remote-control command :

DISP:PSAV ON

### Wait Time - Setup

Sets the wait time for the screen-save mode of the display.

The available value range is 1 to 60 minutes, the resolution 1 minute. The entry is dimensionless.

Remote-control command :

DISP:PSAV:HOLD 10

### Layout - Setup

Selects the keyboard layout for the selected keyboard language.

The assignment of some keys depends on the selected layout and language.

Remote-control command:

KBO:LAY US

KBO:LANG US

## User Marker / AUX I/O - Setup-Environment-Global...Settings

The R&S Vector Signal Generator provides four USER interfaces which can be freely assigned a selection of signals and which can be configured as both inputs and outputs.

The following signals can be applied at the connector:

- **Marker 4:** A broad selection of suitable marker signals is offered in the marker menus of the **Baseband** function. In addition, they can be freely configured in the Control List Editor (**Custom Dig Mod**) and Slot Marker Editor (**GSM/EDGE**). The selected markers are activated when switching on the **Baseband** function. When using markers defined in a control list (Marker = CList) the related control list must be loaded in addition (**Custom Dig Mod**).
- **CW Mode Out:** This signal marks the CW mode in which digital modulation (**Custom Dig Mod**) is deactivated and the RF signal is output in unmodulated form. The CW signal is defined in a control list and activated by loading the control list and setting the **Modulation** ⇄ **CW Switching State** to **On** in the **More** sub menu.  
With standards where it is possible to change between various modulation modes, the signal indicates the active modulation mode (standard GSM: signal high (1) = modulation mode GMSK and signal low (0) = modulation mode 8PSK EDGE). In this cases, the signal is generated automatically when the standard is switched on.
- **No Signal (Blank) Marker:** This signal marks the blank time in the List mode. The signal is generated automatically when the list mode is switched on.
- **HOP:** This signal marks the hop trigger for frequency hopping in the List mode for **Custom Digital Mod**. The hop signal is defined in a control list and activated by loading the control list in the **Custom Dig Mod** menu.
- **Trigger:** This signal marks the trigger event caused by the selected trigger signal (internally or externally). The trigger is defined in the respective trigger submenu of the **Baseband** block menus.



The **User Marker - AUX I/O** menu can be opened using the **SETUP** key under **Environment - Global Trigger/Clock/External Inputs** or in the **Global Trigger/Clock/External Inputs** submenu of the **Trigger** menu, e.g. from the **GSM/EDGE** menu in the **Baseband A/B** function block.

The signals are assigned to the USER interfaces in the Mapping Configuration section. The pin assignment of the AUX I/O connector is also displayed. An adapter between the AUX I/O interface and coaxial BNC connections is available as an accessory (accessories for R&S SMJ-Z5, see data sheet).

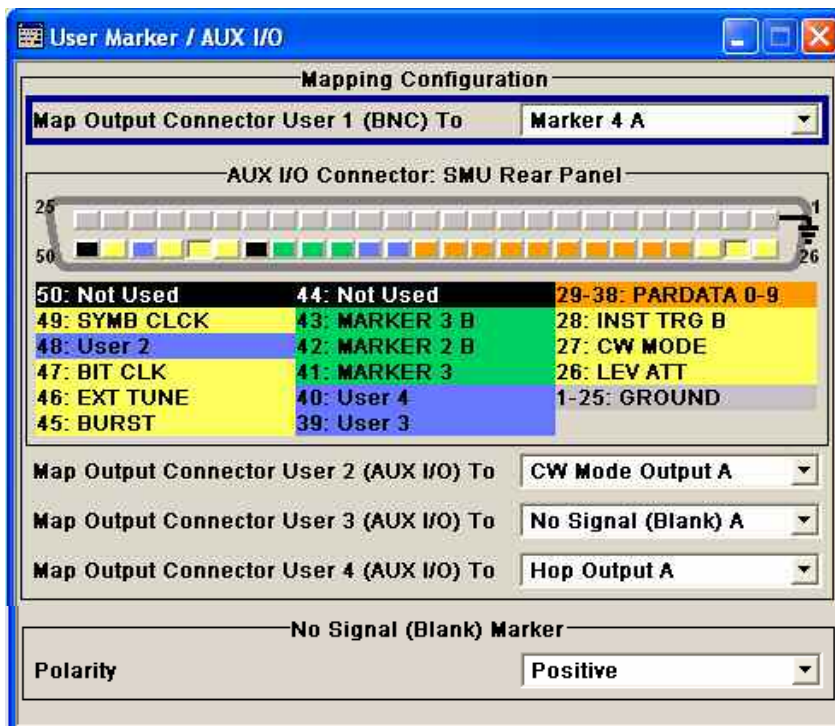
The polarity of the blank marker is selected in the **No Signal (Blank) Marker** section.



**AUX I/O Connector Mapping - AUX I/O Configuration**

An illustration of the AUX I/O interface is shown. The pins are color-coded. The inputs are indicated by a "depressed" pin , outputs by a non-depressed pin .

The assignment is shown in tabular form underneath the interface. The colors indicate the signal type. A distinction is made between control signals (yellow), marker signals (green), data (orange), freely selectable signals at the user pins (blue), ground (gray), and unused pins (black).

Connection	Description
1... 25 - ⊥	Ground
26 - LEV ATT	Signal input/output for controlling the level attenuation. With external envelope curve control ( <b>Custom Digital Modulation</b> only), the pin is the input for the control signal LEV_ATT. With internal envelope curve control, the control signal LEV_ATT is output.
27 - CW MODE	Signal input for controlling the switchover between the modulated and unmodulated RF signal with activated external modulation/CW switching in the <b>Custom Digital Modulation</b> menu (CW control signal).  Signal output for the CW control signal with internal source selected. This signal marks the CW mode in which digital modulation is deactivated and the RF signal is output in unmodulated form. In the case of digital standards with selectable modulation mode, the signal indicates the active modulation mode (GSM: (G)MSK = high, 8PSK EDGE = low)
29 - PARADATA0 ... 38 - PARADATA9	Parallel data input/output 0...D with 10-bit word width for digital modulation. If the data source "external parallel" is selected, these pins are the data inputs. If a different data source is selected, the data is output here (Custom Digital Modulation).



Connection	Description
39 - USER 3	USER input/output which can be configured for various purposes (see above).
40 - USER 4	USER input/output which can be configured for various purposes (see above).
41 - MARKER 3	Output for the freely programmable marker signal 3. The output is permanently assigned.
42...44 - not used	Pins are not used
45 - BURST	Signal input/output for controlling the burst ramp. With external envelope curve control (Custom Digital Modulation only), the pin is the input for the control signal BURST_RAMP. With internal envelope curve control, the control signal BURST_RAMP is output.
46 - EXT TUNE	Tuning input for the internal reference frequency.
47 - BITCLK	Output Bit clock for internal mode.
48 - USER 2	USER input/output which can be configured for various purposes (see above).
49 - SYMBCLK	Symbol clock output for internal mode.
50 - not used	Pin is not used.

#### User Connector Signal - AUX I/O Configuration

Selects the signal for USER interface 1 (BNC), 2, 3 or 4 (AUX I/O). The signals which are available for selection are given above.

Remote-control command:  
 OUTP:USER2:SOUR AMAR

The polarity of the No Signal (Blank) Marker is set in the **No Signal (Blank) Marker** section.

#### Polarity - No Signal Marker - AUX I/O Configuration

Selects the polarity of the No Signal Marker. If **Positive** is selected, the signal is high (2.5 V) when the marker is active; if **Negative** is selected, the signal is low (0 V).

Remote-control command:  
 OUTP:BLAN:POL POS

## GPIB/Ethernet - Setup-Remote

The **Remote Channel Settings** menu provides access to the GPIB and Ethernet settings. The **Remote Channel Settings** menu is opened using the **[SETUP]** or **[MENU]** key under **Remote**.



### GPIB channel address - Remote Channel Settings

Sets the IEC/IEEE-bus address of the instrument.

Remote-control command:  
 SYST:COMM:GPIB:ADDR 28

### TCPIP (Visa Resource String) - Remote Channel Settings

Indicates the visa resource string. This string is used for remote control of the instrument.

Remote-control command:  
 SYST:COMM:NET:RES?  
 Response: TCPIP:192.1.2.3:INSTR

### Local - Remote Channel Settings

Switches the instrument to operate in local control mode.

Switching from remote to local control mode can be also done with one of the following actions:

- manually with the **[LOCAL]** key on the front panel
- with the interface command **&GTL** via the remote-control interface
- with the key combination CTRL + Q

Remote-control command: n.a.

## LXI Status - Setup-Remote

The **LXI - LAN eXtensions for Instruments - Status...** menu displays the settings and status of the LAN and allows to reset the LAN connection.

For more information about LXI, see chapter 5, section "[LXI - LAN eXtensions for Instruments](#)".

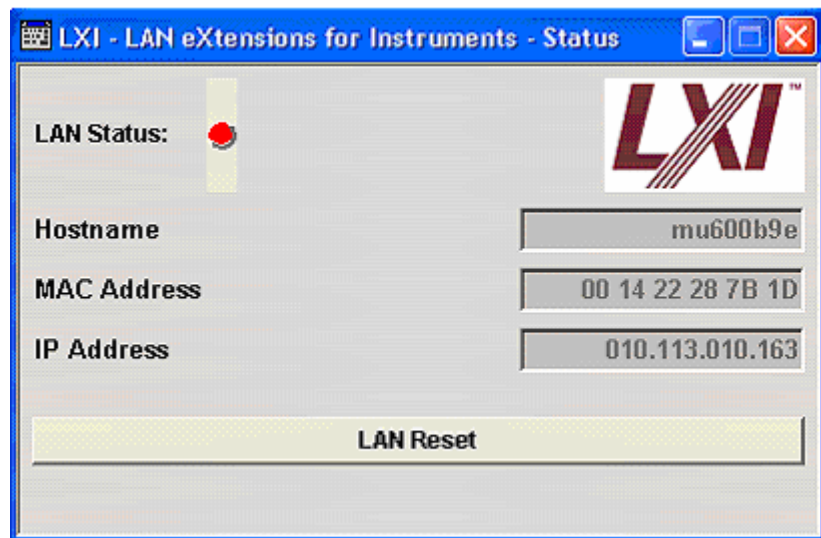

### LAN Status

The LED indicates the LXI status.

The LAN Status is also indicated with the LED **LAN Status** on the front panel of the instrument.

Remote-control command : n.a.

<b>green</b>	normal operation
<b>green (flashing)</b>	device identification
<b>red</b>	LAN fault

**LAN Reset**

Initiates the network configuration reset mechanism for the instrument and resets the hostname, MAC address, and IP address.

According to the LXI standard, an LAN Reset must place the following network settings to a default state:

Parameter	Value
TCP/IP Mode	DHCP + Auto IP Address
Dynamic DNS	Enabled
ICMP Ping	Enabled
Password for LAN configuration	LxiWebIfc

The LAN Reset for the R&S Signal Generator also resets the following parameters:

Parameter	Value
Hostname	<Instrument-specific host name>
Description	Vector Signal Generator
Negotiation	Auto Detect
VXI-11 Discovery	Enabled

The LAN settings are configured using the instrument's **LXI Browser Interface** described in chapter 5, section ["LXI - LAN eXtensions for Instruments"](#).

To open the **Instrument Home Page** (welcome page), type the instrument's computer name (host name) or IP address in the address field of the browser on your PC, .

**Note:**

*Do not add the missing zeros in the IP address, while opening the Instrument Home Page.*

Remote-control command: n.a.

**Protection - Setup-Protection**

The **Protection** menu provides access to the unlocking of protected service functions (authorized personnel of R&S Service Departments only). To unlock the lock-out, the correct password has to be entered. After the instrument has been switched on, the lock-out 2 to 5 is automatically activated.

Protection Level 1 can be activated to lock-out internal adjustment. The password is 123456.



Remote-control command :

```

SYST:PROT1:STAT ON
SYST:PROT1:STAT OFF, 123456
    
```

## Security - Setup -Protection

The **Security...** menu provides access to the passwords and mass storage security settings. It is opened using the **[SETUP]** or **[MENU]** key under **Environment**.

The menu is divided into the password sections and the security settings section. In the password section, the passwords for securing a controlled access to the instrument are defined and changed. In the security section, the remote interfaces are enabled and disabled.

A change of passwords for the operating system and security password requires the entry of the old and new password and the conformation of the new password. All settings are only accepted after the **Accept** button is pressed.



- |                                 |                                                                                                                                                                                                                                                                                                                |
|---------------------------------|----------------------------------------------------------------------------------------------------------------------------------------------------------------------------------------------------------------------------------------------------------------------------------------------------------------|
| <b>Old Password - Setup</b>     | Enters the currently used password. The default password is "123456".<br>Remote-control commands: n.a.                                                                                                                                                                                                         |
| <b>New Password - Setup</b>     | Enters the new password.<br>Remote-control commands: n.a.                                                                                                                                                                                                                                                      |
| <b>Confirm Password - Setup</b> | Enters the new password for conformation.<br>The new password is only valid after the <b>Change Password</b> button is pressed.<br>Remote-control commands: n.a.                                                                                                                                               |
| <b>Change Password - Setup</b>  | Changes the password accordingly.<br>Remote-control command: n.a.                                                                                                                                                                                                                                              |
| <b>USB Device - Setup</b>       | Enables/disables the USB interfaces. Any device connected to the USB interface is not recognized by the instrument when the interface is disabled.<br>The setting requires the entry of the security password and is only accepted after the <b>Accept</b> button is pressed.<br>Remote-control commands: n.a. |

**LAN Connection - Setup**

Enables/disables the LAN interfaces. Any device connected to the LAN interface is not recognized by the instrument when the interface is disabled.

The setting requires the entry of the security password and is only accepted after the **Accept** button is pressed.

Remote-control commands: n.a.

**Security Password - Setup**

Enters the security password that is required to enable or to disable the LAN or USB interface. Default is '123456'.

All settings are only accepted after the **Accept** button is pressed.

Remote-control commands: n.a.

**Accept - Setup**

Accepts a new entry or selection and changes the settings accordingly.

Remote-control command: n.a.

**Save Recall - Setup-Setting**

The **Save/Recall** submenu can also be called up with the **[FILE]** key and is therefore described in the section on this key (see section "[Storing and Loading Instrument Data - File Key](#)", page 4.28).

**Factory Preset - Setup-Setting**

The **Factory Preset** submenu provides a function to reset the instrument's settings to their factory state. This function is activated by pressing the **Execute Factory Preset** button.

**Note:**

*Since **Factory Preset** resets the Remote Channel and network settings to the default values, executing Factory Preset via remote control terminates the connection to the instrument, if these settings had been configured to values different to the default ones!*

The **Factory Preset** function resets nearly all instrument settings. In addition to the regular preset by means of the **[PRESET]** key, a **Factory Preset** resets also the following values:

- Reference frequency settings (Ref Oscillator menu)
- Power on settings (Level/EMF menu)
- Network settings including hostname (Setup menu)
- Remote Channel settings including IEC/IEEE-bus address and emulation (Setup menu)
- Start/Stop Gui Update (Setup menu)
- Display and keyboard settings (Setup menu).

To maintain security, password settings and all settings protected by these passwords like disabled USB and LAN connections are not changed.

Not affected by the **Factory Preset** are also user data, lists or instrument settings files, created for example by means of the Save/Recall function.



Remote-control command:

SYST:FPR

## Help - Setup-Help

The **Help** submenu offers comprehensive online help for the R&S Vector Signal Generator. A desired topic can be selected via the table of contents (select **Manual**) or the index (select **Index**).

For context-sensitive information about a marked parameter, press the **[HELP]** key. For a description of the **Help** menu, refer to the section covering to the **[HELP]** key (see section "[Help System - Help Key](#)", on page 4.26).

## Switching to Manual Control - Local Key

In remote control mode a status message appears in the display header. The rest of the display remains unchanged and shows the current instrument status, i.e. the status which exists under the remote control settings. The instrument can be operated (e.g. menus can be opened). However, it is not possible to enter or change values.

The status message additionally indicates whether the **[LOCAL]** key is disabled or enabled (see also Chapter 5, section "[Switch-Over to Remote Control](#)").

If the **REMOTE** status message is shown, the **[LOCAL]** key switches the instrument from remote control to manual control. The current command must be fully processed before the mode is switched, otherwise the instrument switches immediately back to remote control.

If the **REM-LLO** status message is displayed, the instrument can be switched from remote control to manual control by means of remote control only (e.g. with the Visual Basic command `CALL IBLOC (generator%)`); the **[LOCAL]** key is disabled. The key is disabled by remote control with the command **LLO**.

When switching from remote to manual control, the display update suppression function, if active (**[SETUP]- GUI Update is Off**), is automatically deactivated (**[SETUP]- GUI Update is On**).

## Generating a Hardcopy of Display - Hcopy Key

The **[HCOPY]** key is without function for the Vector Signal Generator.

## Messages - Info Key

The **[INFO]** key opens a window containing a detailed description of every message displayed in the info bar, see chapter 3, section "[Info and Status Bar](#)" and chapter 9, section "[Error Messages](#)".

## Help System - Help Key

The **[HELP]** key opens a browser window containing a context-sensitive description of the highlighted parameter.

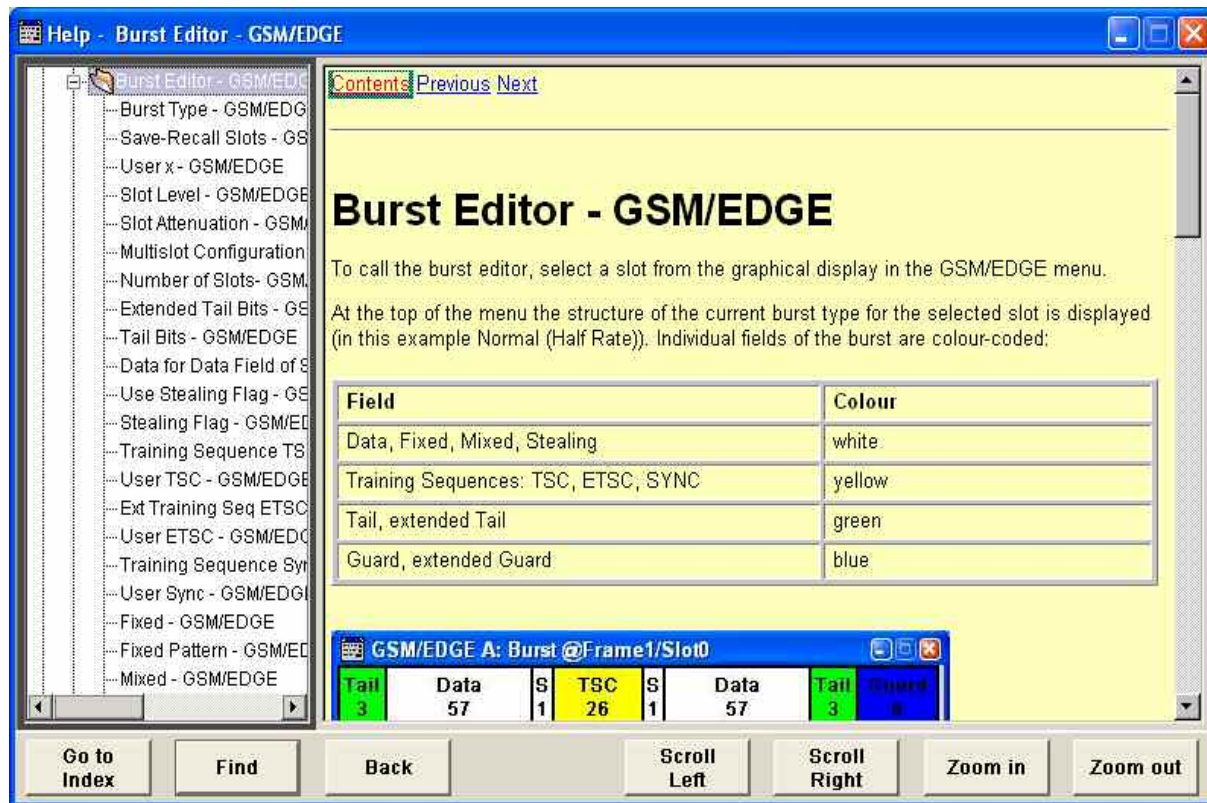

The context-sensitive page which is opened with the **[HELP]** key is part of a comprehensive help system. It is possible to move from this context-sensitive page to any page of the help system. The following navigation aids are available:

- **Internal links in the text**  
They open pages which are directly linked to the described function. In this way it is possible, for example, to call up the description of the IEC/IEEE-bus command for any particular function.
- **Previous/Next links**  
The Previous/Next links allow scroll through the help pages. The sequence of the described functions corresponds to their position in the menus.
- **Back softkey**  
The Back softkey calls up the page last viewed.
- **Contents in the navigation panel**  
The contents list is used to open the individual help pages. It has a hierarchical structure. The highlighted line indicates where the currently displayed page is within the contents list.
- **Index in the navigation panel**  
The index is used to call up all pages which contain the selected entry. The index has an alphabetical structure and also contains all IEC/IEEE-bus commands.
- **Text search softkey**  
The text search allows you to look for freely selectable terms in all help pages. A list of the pages containing the entered term is displayed as the search result. The search can be limited to words in the page title to increase the number of hits.



The softkeys are used to determine the entry focus for front panel operation, to select the content of the navigation window and to change the font size. To determine the entry focus for front panel operation the Cursors UP/Down are used. The links are highlighted in blue, and can be selected and called up using the rotary knob.

**Index / Tree - Help**

Switches the navigation window display between the contents tree and index entries. The input focus must be in the left-hand navigation window.

Remote-control command: -

**Contents tree:**

The contents tree is the contents list of the help system. The cursor always highlights the entry which is currently being displayed in the right-hand help window. The associated page can be opened by selecting an entry.

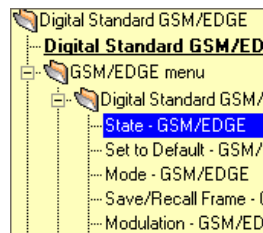

**Index:**

The index contains an alphabetical list of all terms which refer to functions of the instrument. For example, it contains all parameter names and all IEC/IEEE-bus commands. The associated help page can be opened by selecting an entry.

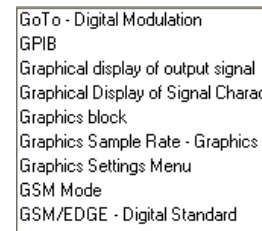

**Find - Help**

Opens the search panel. The content of the titles only or the complete help text can be searched for the entered term.

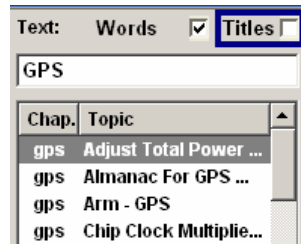

Remote-control command: -

**Scroll Left / Scroll Right - Help**

Shifts the indicated area of the navigation window.

Remote-control command: -

**Zoom in / Zoom out - Help**

Increases and reduces the font size of the help text.

Remote-control command: -

## Storing and Loading Instrument Data - File Key

The R&S Vector Signal Generator allows complete instrument settings to be stored in files on the hard disk. Defined and complex instrument settings can then be reproduced at any time by loading this data. If required, these settings can be loaded to various signal generators.

The **FILE** key opens the menu used to store and load instrument settings in a file. The data can be stored on the hard disk in a data directory. Additionally there are three intermediate memories in which the current instrument setting can be stored and then called up again by pressing a key. This makes it possible to switch quickly between defined instrument settings.

All settings which differ from the preset plus the configuration data for the operating elements (e.g. window positions) are stored. When loaded, these referenced settings are implemented and all non-referenced parameters are set to the associated preset value. As a result the files remain relatively small since they only contain the relevant information. Furthermore, this also allows instrument settings to be transferred easily between different signal generators since once again only the settings which differ from the preset values have to be adjusted.

If a list, e.g. a frequency/level list, is used for the LIST mode or a list of frame or channel configurations is used for a digital standard, a reference to this list is also stored. The list is also loaded when the associated instrument setting is loaded. If the list has been deleted in the meantime (or it is not available on a different instrument), an error message appears if an attempt is made to access this list after the instrument setting has been loaded. The associated setting or operating mode, e.g. the List mode, is only started after the user has selected an existing list. If the list has been overwritten in the meantime, the new entries will be used.

---

**Note:**

*Lists are stored and loaded in the appropriate menus. For example, the GSM frame definitions are created and stored in the GSM menu.*

---

When loading an instrument setting, it is possible to select whether the current frequency and level setting is to be retained or whether the stored settings are to be activated. It is possible to delete stored instrument settings. A file can be copied by loading it with "Recall" and then storing it under a new name.

Settings can be transferred easily between instruments with different equipment options and/or firmware versions because only the settings which differ from the preset values are affected. When settings are loaded, only those which are possible on the instrument are implemented. Error messages indicate the settings which cannot be implemented.

The stored file is transferred from one instrument to another using the memory stick or by means of a network drive.

General file management functions such as copying and moving data are available in the **File Manager** submenu.

## File Menu

The settings available in the File menu depend on the operation selected under **Select Operation**.



<b>Select Operation - File</b>	Selects the file function.
<b>Save...</b>	Calls the menu for storing the current instrument setting.
<b>Recall...</b>	Calls the menu for calling up a stored instrument setting.

## Storing Instrument Settings - File

If **Save** is selected under **Select Operation**, the File menu provides options for storing the current instrument setting in a file.

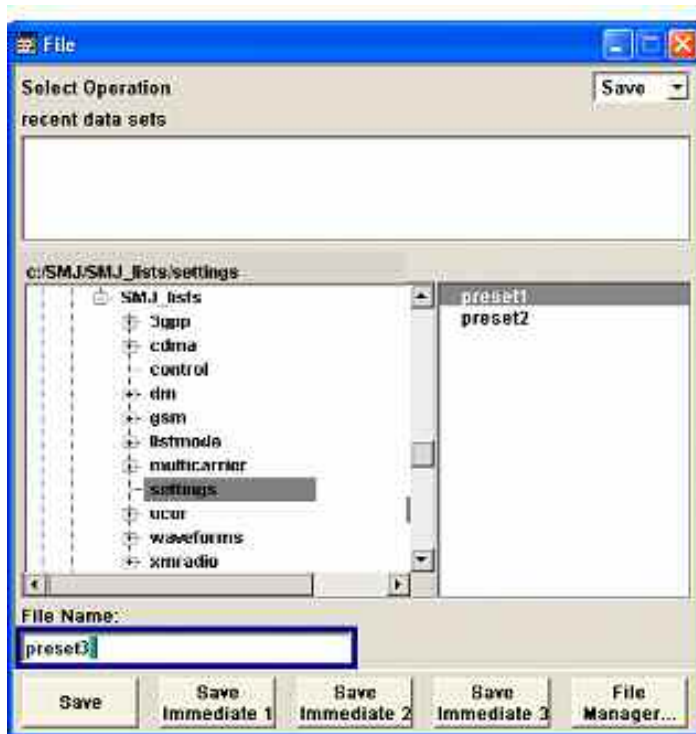

<b>Recent data sets - File</b>	Displays the files last used. The entire path is shown in plain text. Remote-control command: n.a.
--------------------------------	-------------------------------------------------------------------------------------------------------

<b>Directory - File</b>	<p>Selects the directory in which the file is to be stored. The window opposite lists all settings files in this directory. A new directory can be created in the File Manager (<b>File Manager</b> button).</p> <p>Remote-control command: MMEM:CDIR "D:\user" (The path can also be entered when the file is stored.)</p>
<b>File List - File</b>	<p>Displays the files which are in the selected directory. If a file is highlighted, it is overwritten when the file is stored.</p> <p>Remote-control command: MMEM:CAT?</p>
<b>File Name - File</b>	<p>Enter the file name of the file without file extension. This file is then created.</p> <p>Remote-control command: n.a. (The file name is entered when the file is stored.)</p>
<b>Save - File</b>	<p>Stores the current instrument settings under the specified path.</p> <p>Remote-control command: *SAV 4 MMEM:STOR:STAT 4, 'D:\test.savrcl'</p>
<b>Save Immediate x- File</b>	<p>Stores the current instrument setting in one of the three intermediate memories.</p> <p>These instrument settings are retained until a different instrument setting is stored in the intermediate memory. When the instrument is switched off, the contents of the intermediate memories are retained.</p> <p>Remote-control command: *SAV 1</p>
<b>File Management- File</b>	<p>Calls the <b>File Management</b> menu.</p> <p>Directories can be created and files managed in this menu (see the section "<a href="#">File Manager - File</a>", page 4.33").</p> <p>Remote-control command: n.a.</p>

## Loading Instrument Settings - File

If **Recall** is selected under **Select Operation**, the **File** menu provides options for loading complete instrument settings. Here it is possible to select whether the current or stored RF frequency and RF level settings are to be used.

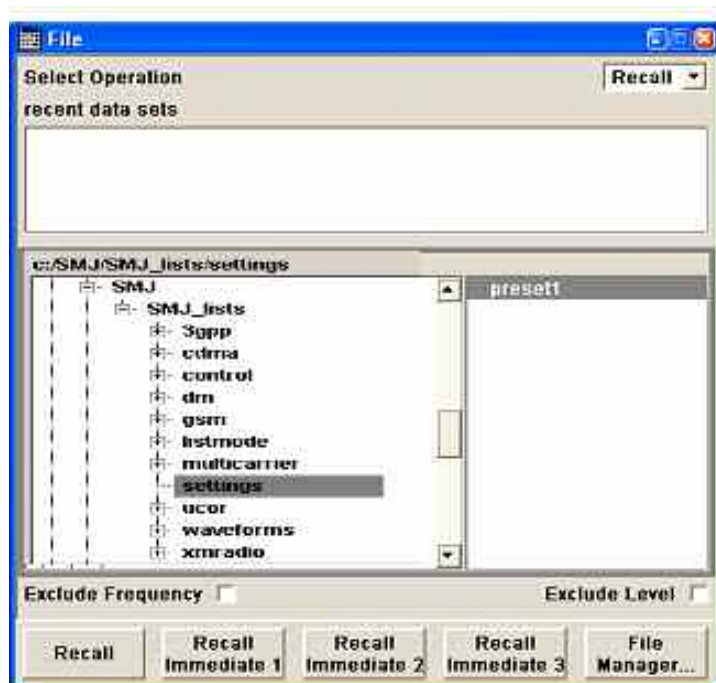

### Recent data sets - File

Displays the files last used. The entire path is shown.

If the desired file is in the list, it can be selected in this window.

Remote-control command: n.a.

### Directory - File

Enter the directory in which the file with the instrument setting to be loaded is located.

The **Selected file** window lists all the files in this directory.

Remote-control command:

MMEM:CDIR "D:\user"

### File List - File

Selects the file with the desired instrument configuration.

Remote-control command:

MMEM:CAT?

### Exclude Frequency - File

The current frequency is retained when a stored instrument setting is loaded.

Remote-control command:

SOUR1:FREQ:RCL EXCL

<b>Exclude Level - File</b>	<p>The current level is retained when a stored instrument setting is loaded.</p> <p>Remote-control command: SOUR1:POW:RCL EXCL</p>
<b>Recall - File</b>	<p>Load the selected configuration.</p> <p>If an instrument setting in which a sweep was activated is stored, the sweep is started when the recall command is called.</p> <p>If an instrument setting which accesses lists is stored, this list is also loaded.</p> <p>If the list has been deleted in the meantime, an error message appears when the instrument setting is loaded. If the list has been overwritten in the meantime, the new entries will be used.</p> <p>Remote-control command: MMEM:LOAD:STAT 4, 'D:\test.savrcl' *RCL 4</p>
<b>Recall Intermediate x- File</b>	<p>Loads the selected configuration from one of the three intermediate memories.</p> <p>If an instrument setting in which a sweep was activated is stored, the sweep is started when the recall command is called.</p> <p>If an instrument setting which accesses lists is stored, this list is also loaded.</p> <p>If the list has been deleted in the meantime, an error message appears when the instrument setting is loaded. If the list has been overwritten in the meantime, the new entries will be used.</p> <p>A message appears if no instrument configuration is stored in this memory.</p> <p>Remote-control command: *RCL 1</p>

## File Manager - File

The **File Manager** menu provides all the functions required for file management. Directories can be created, and files copied, deleted and moved between the directories on the drives (hard disk, memory stick and network drives).

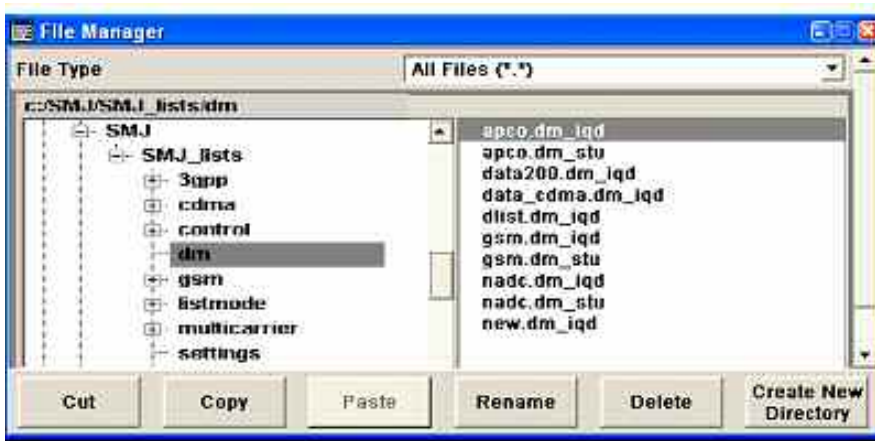

### File Type - File Manager

Selects the file types to be indicated. If a file type with a specific file extension (e.g. List Mode List (\*.lsw)) is selected only files with this extension are indicated in the selected directory.

Remote-control command: n.a.

### Directory - File Manager

Selects the directory in which the file to be deleted or copied is located. The window to the right lists all files in this directory. The file to be deleted or copied can be highlighted. The path is indicated above the directory window.

Remote-control command:

MMEM:CDIR "D:\user"

### File Name - File Manager

Selects the file.

Remote-control command: n.a.

### Cut - File Manager

Cuts the selected file. It can be pasted into a different directory using the **Paste** button.

Remote-control command:

MMEM:DEL 'E:\test.savercl'

### Copy - File Manager

Copies the selected file. It can be pasted into a different or the same directory using the **Paste** button. When pasting the file into the same directory file name "Copy of <filename>" is given automatically. When pasting the file into a different directory, the original filename is kept.

Remote-control command:

MMEM:COPY "D:\user\set1.wv", "D:\user\set2.wv"

### Paste - File Manager

Pastes the file that has been copied or cut before.

Remote-control command: n.a.

**Rename - File Manager** Renames the selected file or directory. The new name can be entered in the **New Filename** window.

Remote-control command:

```
MMEM:MOVE "test02.dm_iqd","set2.dm_iqd"
```

**Delete - File Management** Deletes the selected file. Before the file is deleted, a message appears prompting the user to confirm deletion of the file.

Remote-control command:

```
MMEM:DEL 'E:\test.savrcl'
```

**Create New Directory - File Management**

Creates a new directory. The name of the new directory can be entered in the **New Directory** window.

The directory is created as a subdirectory in the selected level.

Remote-control command:

```
MMEM:MDIR 'D:\user\test'
```

---

**Note:**

*When the subdirectory is entered, it is possible to enter an absolute path name (e.g. "D:\USER\MEAS") or the path relative to the current directory (e.g. "..\MEAS").*

---



# Graphical Display - Graphics

## Graphical Display of Signal Characteristics

The R&S Vector Signal Generator can be used to graphically display the generated baseband signal. A selection of different signal displays assists the user in assessing and checking the increasingly complex modulation signals.



The Graphics function block is available for instruments with the option R&S SMJ-B13 (Baseband Main Module) and one of the options R&S SMJ-B10/B11 (UniCod + ARB), or R&S SMJ-B62 (Noise Generator).

It is the baseband signal actually generated that is recorded and displayed, and not a signal calculated on the basis of the set parameters.

This graphical display allows the user to quickly view and check the current signal characteristics and also gives an overview of the changes in the signal over time. The signal quality can be permanently monitored. The results of parameter changes on the signal, such as a change in modulation mode, or the effects of certain configurations, e.g. the activation of several base stations in the case of (W)CDMA signals, can be analyzed directly in the display. Freezing the signal and then zooming permit a detailed evaluation of any signal segment. The definition and display of one or more reference curves makes it possible to compare various signals (i.e. by comparing the CCDF (Complementary Cumulative Distribution Function) with different channelization codes, or the spectra if different filter parameters are selected).

The displayed signal segment can be influenced by selecting the trigger that defines the time for recording to start. With automatic triggering, the signal is tapped at the point in the signal path that is best for the respective display. The displayed signal segment is selected internally depending on the signal such that the signal characteristics of interest (e.g. the useful signal) are displayed. This selection is appropriate for a representative display of the complete signal.

In addition, a user-definable trigger is available with which the displayed signal segment can be limited.

The time resolution can be set either automatically or manually, whereby for manual setting the bandwidth for which the trace is to be displayed is selected. The transient recorders used for signal recording have a variable recording depth which is specified under the respective display.

In addition to the large graphics window, the display can also be shown in a small window ("smart graphics"). This window is fitted into the block diagram as a block, and can be used for basic checking purposes (e.g. whether the signal is still being generated).

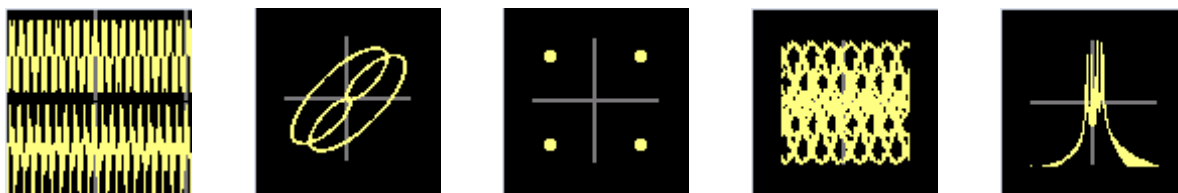

## Graphics Settings Menu

The **Graphics Settings** menu for selecting the graphical display of the output signal is opened either in the **Graphics** function block or in the menu with the same name which is opened using the **[MENU]** key.

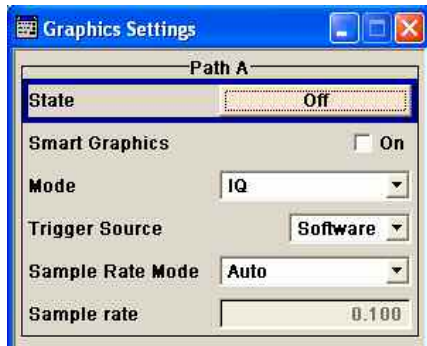

The signal display can be selected and activated in the menu.

### Status - Graphics Settings

Activates the selected graphical display.

After activation, the diagram selected with **Mode** is displayed in the block diagram.

At the bottom of each graphics window there are several buttons for freezing and zooming the display and for activating a reference curve (see the following section "[Softkey Bar of Graphics Window](#)", page 4.38).

Remote-control command: n.a.

### Smart Graphics - Graphics Settings

Activates the "smart graphics".

The graphic is displayed in a small window which is roughly the size of a block. These windows are displayed permanently in the block diagram until they are deactivated, and allow basic checking of the signal. They do not contain any buttons.

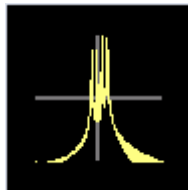

Remote-control command: n.a.

### Mode - Graphics Settings

Selects the graphical signal display. The display is not shown until it has been activated with **Status On**.

The individual signal displays are described in the following sections under "[Signal Displays - Graphics](#)", from page 4.41 onwards.

Remote-control command: n.a.

<b>Trigger Source - Graphics Settings</b>	<p>Defines the trigger for the starting time of the graphic recording.</p> <p>Remote-control command: n.a.</p>
	<p><b>Software</b>                      Recording of signals is started automatically in specified intervals.</p> <p>This asynchronous method is appropriate when a representative display of the complete signal is desired, as recording starts in a random time reference to the signal.</p>
	<p><b>Marker 1</b>                      The starting point for recording signals is determined by marker 1 in the menu of the active standard.</p> <p>This synchronous method is appropriate when specific signal segments are to be shown in greater detail. With periodic signals, a static image is obtained by selecting a period length of marker 1 that is equal to the signal period.</p> <p>The displayed signal segment can be shifted as needed by entering a marker delay in the Trigger/Marker menu of the active standard.</p>
<b>Scrambling Code - Graphics Settings</b>	<p>(only if Code Domain (3GPP FDD DL) is selected) Sets the scrambling code if the <b>Code Domain</b> display is selected. Since it is possible to select a different scrambling code in the menu for each of the 4 base stations and it is also possible to display an external signal, the scrambling code for which the display is to be generated must be explicitly specified here.</p> <p>Remote-control command: n.a.</p>
<b>Sample Rate Mode - Graphics Settings</b>	<p>Sets how the time resolution of the signal is determined. Maximum resolution corresponds to a display covering the entire signal bandwidth. The higher the resolution is, the shorter the length of the displayed signal segment will be for the specified recording depth.</p>
	<p><b>Auto</b>                              The resolution is set to an optimum value on the basis of the signal and display type.</p> <p>Remote-control command: n.a.</p>
	<p><b>Full Bandwidth</b>              The resolution is set such that the display covers the entire signal bandwidth.</p> <p>Remote-control command: n.a.</p>
	<p><b>User</b>                              Under <b>Graphics Sample Rate</b>, the user can determine the resolution by setting the signal bandwidth for which the display is to be generated.</p> <p>Remote-control command: n.a.</p>

**Graphics Sample Rate -  
Graphics Settings**

With **Auto** and **Full Bandwidth**:

Displays the signal bandwidth for which the display is to be generated.

With **User**:

Selects the signal bandwidth for which the display is to be generated.

The setting range moves between the minimum and maximum bandwidth which is possible for the selected display. The selection is made graphically by moving the pointer.

Remote-control command: n.a.

**Softkey Bar of Graphics Window**

At the bottom of each graphics window there are buttons for freezing and zooming the display and for defining and activating a reference curve.

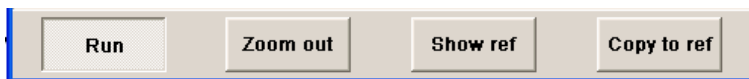
**Run**

Freezes the current display.

Clicking the button again reactivates the normal, permanently updated display.

Freezing the display allows it to be analyzed more easily. Zooming the display at the same time permits detailed evaluation of any signal segment.

Remote-control command: n.a.

**Zoom In**

(only possible with mouse)

The mouse can be used to freely select any section to be zoomed.

This section is selected by pressing the left-hand mouse key and dragging a rectangular marquee. In this way a display can be zoomed in several steps. The zoom is cancelled by clicking the **Zoom Out** button.

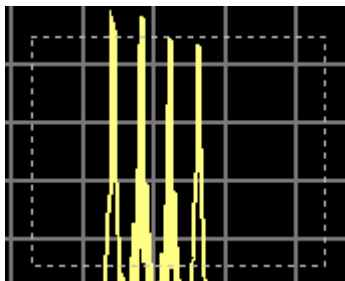

Remote-control command: n.a.

**Zoom out**

Cancels the zoom.

Remote-control command: n.a.

**Time**

(I/Q mode only)

Switches to seconds for time representation on the X axis of the I/Q diagram.

Remote-control command: n.a.

**Show ref**

Displays the reference curve(s). All defined reference curves are displayed simultaneously (see the description of the **Copy to ref** button).

The reference curves are displayed together with the current signal. They allow visual comparison of two or more signals with different settings, e.g. with different filters.

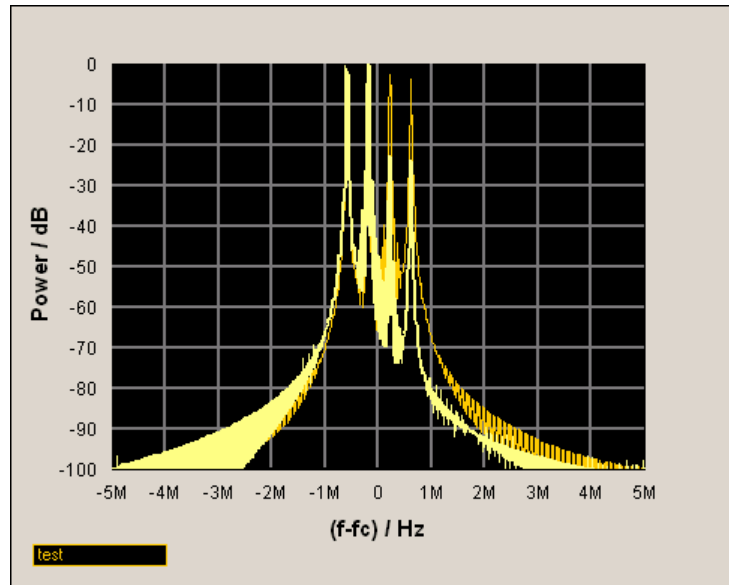

Clicking the button again hides the reference curves.

The reference curves must be defined beforehand using the **Copy to Ref** button.

Remote-control command: n.a.

**Copy to ref**

Defines the current curve as the reference curve.

A window opens in which the curve can be given a comment and a color.

First of all the desired color is highlighted in the top window. If this color has already been assigned to a reference curve, this curve is overwritten. The command is entered in the bottom **Comment** section. This comment then appears next to the highlighted color.

Up to 5 reference curves can be defined and displayed simultaneously in different colors together with the current signal.

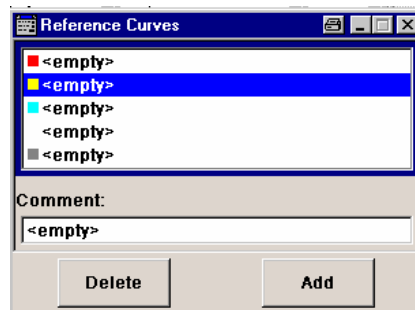

Each reference curve is available until it is deleted.

Remote-control command: n.a.

**Display area** The comments entered for the defined reference curve are shown in the display area next the assigned color. A maximum of five colors (and reference curves) are available. If no reference curve is assigned to a particular color, the comment <empty> is displayed.

Remote-control command: n.a.

**Comment** Enters a comment for the current curve which is to be defined as the reference curve. This comment then appears next to the highlighted color in the display area.

Remote-control command: n.a.

**Delete** Deletes the curve highlighted in the display area.  
Curves which are no longer required can be deleted to reduce the number of reference curves displayed simultaneously.

Remote-control command: n.a.

**Assign** Defines the current curve as the reference curve.  
The new reference curve is shown together with the entered comment next to the selected color in the display area.

Remote-control command: n.a.

## Signal Displays - Graphics

All signal displays which are used for analyzing a baseband signal can be selected. A number of signal displays are only available if the corresponding signal is generated, e.g. Code Domain only available for (W)CDMA signals.

### I/Q Diagram - Graphics

The I/Q diagram displays the inphase component ( $i(t)$ ) and quadrature component ( $q(t)$ ) of the I/Q signal over time.

The diagram is displayed in a window with two separate coordinate systems. The coordinate systems have identical X and Y axes. The time (in number of symbols, chips or samples depending on the signal) is plotted on the X axes, and the amplitude scaled to the peak envelope power (PEP) is plotted on the Y axes (minimum scaled amplitude = -1; maximum scaled amplitude = +1). The recording depth is 1 kSamples.

This signal is picked off at the output of the baseband main module (**Impairment** function block). Impairment of the signal as defined by the user and the addition of noise is contained in the displayed signal.

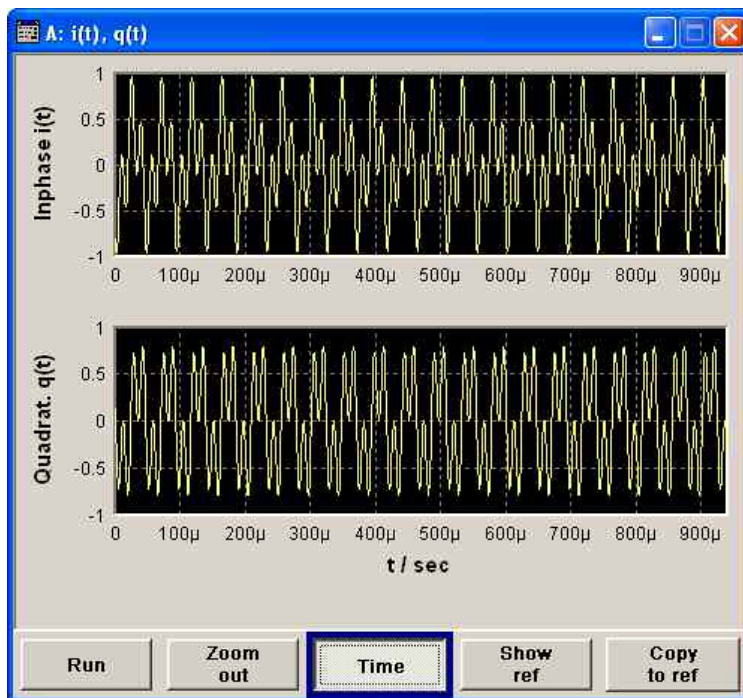

## Vector Diagram - Graphics

The Q component is displayed over the I component in the vector diagram. Each point is determined by a vector. The amplitudes of the signal components scaled to the peak envelope power (PEP) are plotted on the X and Y axis (minimum scaled amplitude = -1; maximum scaled amplitude = +1).

This display shows the curves between the various states of modulation mapping. The recording depth is 1 kSamples.

This signal is picked off at the output of the baseband main module (**Impairment** function block). Impairment of the signal as defined by the user and the addition of noise is contained in the displayed signal.

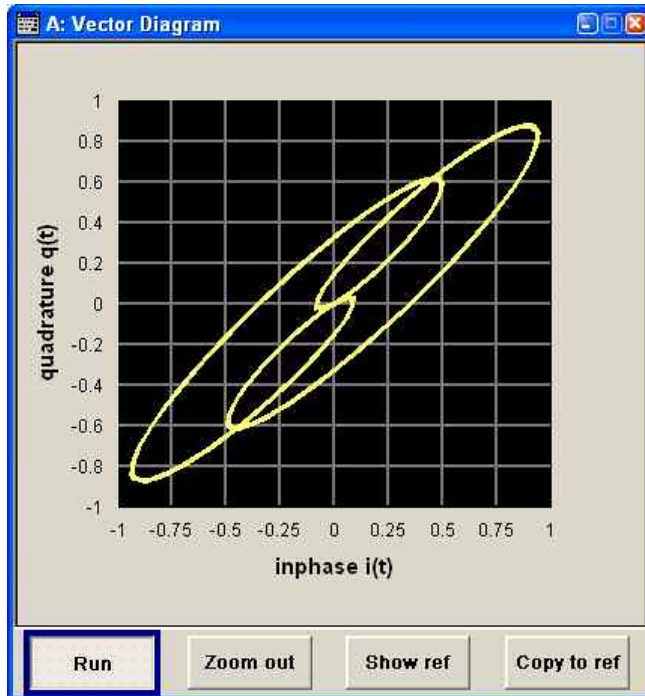



## Constellation Diagram - Graphics

In the constellation diagram, the Q component is also displayed over the I component. However, only the values at the constellation points (signal value at the ideal scanning instant of the symbol) are displayed, i.e. for each symbol only 1 value in the form of a circle is shown for the I and Q component.

The amplitudes of the signal components scaled to the peak envelope power (PEP) are plotted on the X and Y axis (minimum scaled amplitude = -1; maximum scaled amplitude = +1). The recording depth is 2kSamples.

This signal is picked off at the output of the unocoder (**Baseband** function block) upstream of baseband filtering. Impairment of the signal as defined by the user and the addition of noise is not effective in this signal because signal impairment and noise addition occur further down the signal path.

This display shows the various states of modulation mapping which occur in the signal. The example shows the constellation diagram of a QPSK modulation signal.

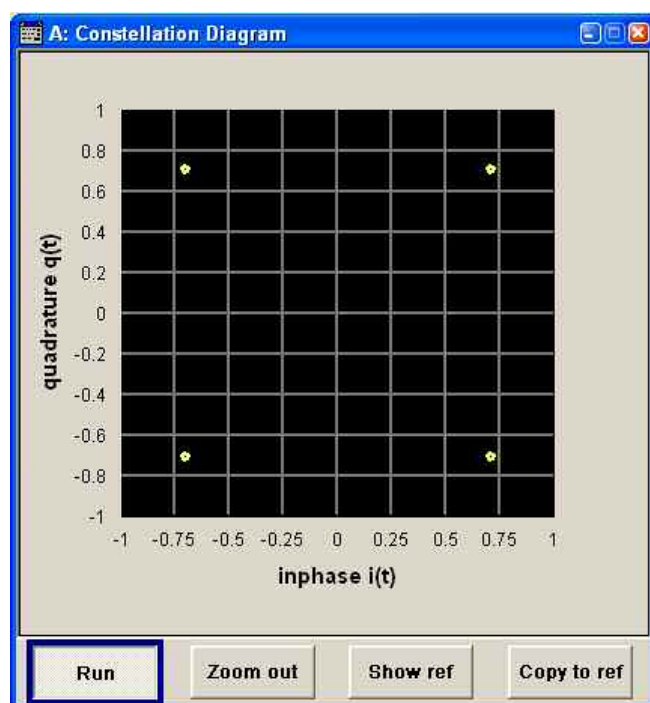

## Eye Diagram - Graphics

The eye diagram displays synchronized and superimposed sections of either the inphase or quadrature components of the signal.

The display width (eye length) is set at 2 symbols; several hundred curve segments are superimposed. The time (in the range  $\pm 1$  symbol) is plotted on the X axis, and the amplitude scaled to the peak envelope power (PEP) is plotted on the Y axis (minimum scaled amplitude = -1; maximum scaled amplitude = +1). The beginning of recording is synchronous to the symbol and chip clock pulse. The recording depth is 2kSamples.

This signal is picked off at the output of the uncoder (**Baseband** function block) downstream of baseband filtering. Impairment of the signal as defined by the user and the addition of noise is not effective in this signal because signal impairment and noise addition occur further down the signal path.

The exactness of the superimpositions and therefore the size of the eye gaps depend on the used filter.

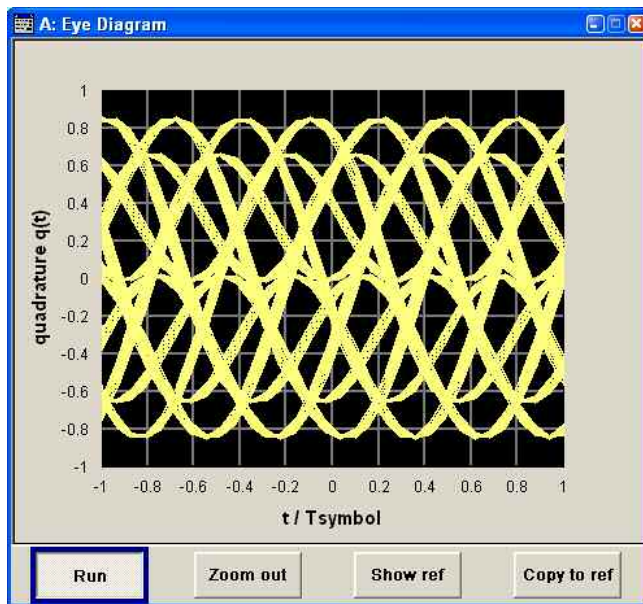

## CCDF Display - Graphics

The **Complementary Cumulative Distribution Function** shows the probability with which the output signal will exceed the average power.

The level over the average power is plotted from 0 to 20 dB on the X axis; the average power (RMS) corresponds to the origin. The probability of exceeding the average power is plotted between 0.0001% and 100% on the Y axis. The recording depth is 8kSamples.

This signal is picked off at the output of the baseband main module (**Impairment** function block). Impairment of the signal as defined by the user and the addition of noise is not effective in this signal because signal impairment and noise addition occur further down the signal path.

The point at which the CCDF curve intersects the X axis gives the crest factor of the signal.

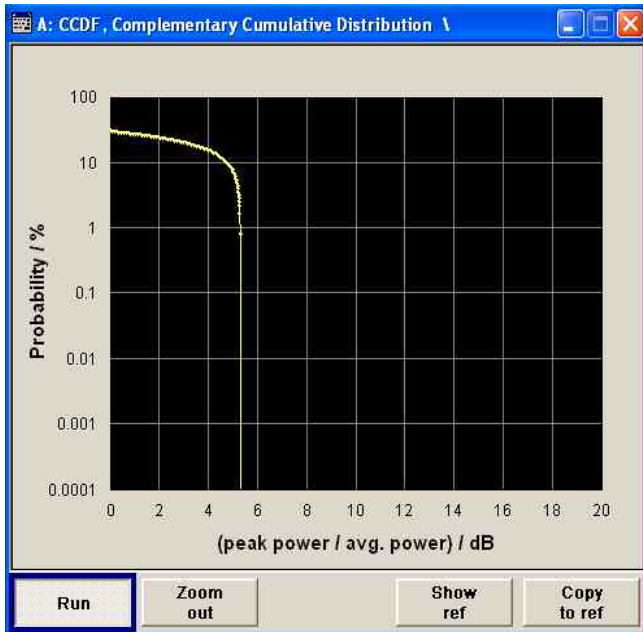

## Power Spectrum - Graphics

With the spectrum display, the signal spectrum is calculated from the I/Q signal by means of Fast Fourier Transform (FFT).

The power density over frequency is displayed. The power density is plotted on the Y axis, and the frequency is plotted symmetrically on the X axis (-sampling rate/2 to +sampling rate/2). FFT Points indicates the number of I/Q value pairs which are used for calculating a (part-)FFT. AVG indicates the number of subspectra used for averaging. The recording depth is 8kSamples.

This signal is picked off at the output of the baseband main module (**Impairment** function block). Impairment of the signal as defined by the user and the addition of noise is contained in the displayed signal.

The spectrum display of the output signal is particularly suitable for checking multi carrier signals.

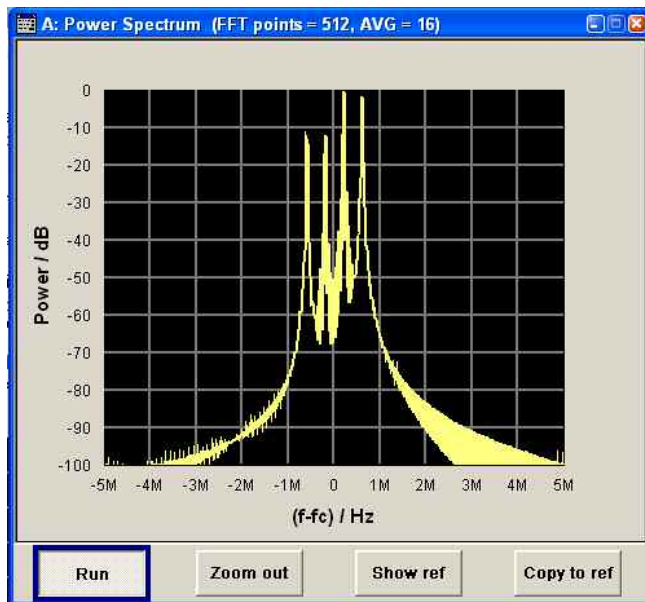

# Bit and Block Error Rate Measurements - BERT Block

## Introduction - Bit and Block Error Rate Measurements

The R&S Vector Signal Generator contains an integrated bit error rate tester which makes it possible to evaluate a signal demodulated and decoded by a DUT by measuring the bit error rate. A known PRBS-modulated data sequence (PRBS = pseudo random binary sequence) is sent to the DUT. The PRBS data sequence is decoded by the DUT and sent to the R&S Vector Signal Generator in the form of clock and data signals. The bit error rate tester of the R&S Vector Signal Generator synchronizes to the known PRBS sequence and counts the bit errors. The quotient obtained by dividing the number of error bits by the total number of bits is the BER.

In addition, a block error rate measurement can be used to verify CRC checksums. The ratio of errored blocks to total blocks yields the block error rate.

The settings are shown in the block diagram in the **BERT** function block and in the menu of the same name that is accessed via the **MENU** button.

The equipment layout for the basic unit (R&S Vector Signal Generator with B10x frequency option) includes the option K80 (Bit Error Rate Tester).

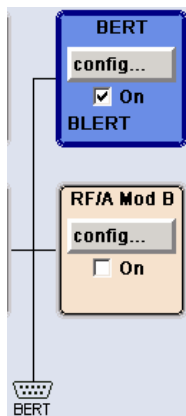

The **BERT** interface is located on the rear panel. Besides the data and clock input, it provides other inputs with which the user data containing the PRBS sequence can be masked. The interface description can be found in chapter 8, section "[BERT Interface](#)".

### Test setup

The following figure shows the test setup for the bit/block error rate measurement. The data used to drive the DUT can be generated by the R&S Vector Signal Generator or an user-defined external source. The R&S Vector Signal Generator can generate any externally computed modulation signals that were created using e.g. **WiniQSIM** software (see section "[Arbitrary Waveform Generator](#)").

A known PRBS sequence must be used for the bit error rate measurement.

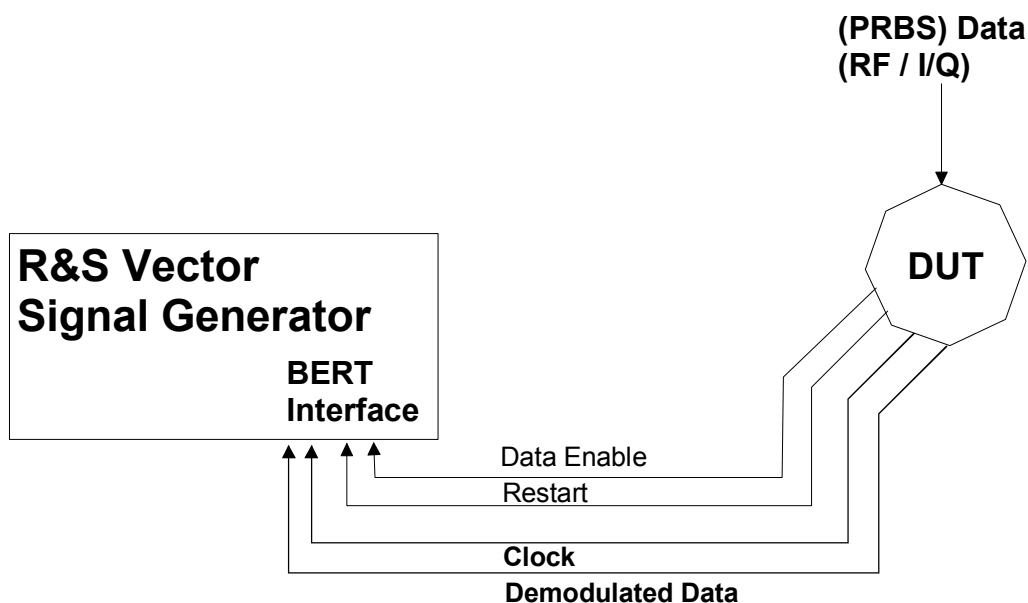

Fig. 4-1 Test setup for bit or block error rate measurement. The DUT is driven using a known data sequence. It demodulates the data and sends it together with a clock signal to the R&S Vector Signal Generator. The Data Enable signal marks the user data of the signal. The restart signal for restarting the PRBS calculation is only important for the bit error rate measurement.

### PRBS data – bit error rate measurement

To be able to detect faulty bits by a BER measurement, the data generation polynomial must be known. PRBS sequences are therefore used as the method for computing the data (see "[Internal PRBS-Data and Data Pattern](#)" section). These quasi-random bit sequences are repeated periodically, depending on the polynomial selected. A randomly selected initial status yields exactly one subsequent status. The initial status and therefore the subsequent status occur only once in the whole sequence.

Hence an advantage of the PRBS data is that the bit error detector must know only the polynomial but not the entire sequence. At the start of a measurement, the feedback shift register is filled once with the applied data sequence (which corresponds to the synchronization time) and is subsequently switched from "fill" to "feedback". This creates a defined initial status and generates exactly the same data that the applied data stream should have. Faulty bits can thus be identified and counted by comparing the received data with the results obtained from the shift register.

Creating a defined initial status makes it possible to start the analysis anywhere in the bit stream, i.e. the bit-stream source and the analyzer need not be synchronized. Delays of the DUT and transmission over long air paths, where the transmitter and the receiver are located at separate sites, therefore do not present a problem.

### CRC polynomial – block error rate measurement

In the block error rate measurement, the checksum (CRC) that contains the data signal fed to the DUT is compared with the checksum that the block error rate tester calculates from the feedback data. If the two checksums differ, a block error is counted. The quotient obtained by dividing the number of faulty blocks by the total number of blocks is the block error rate.

At the beginning of the data, the shift register is initialized with 0. All user data bits are then shifted through the shift register. The CRC component is then read into a second register and compared bit by bit with the result of the calculation.

CCITT CRC 16 :  $G(x) = x^{16} + x^{12} + x^5 + x^1$  is the CRC polynomial supported.

The user data is marked by a signal that comes from the DUT and is fed to the **Data Enable** input of the BERT interface.

### Clock signal

Usually the clock signal is provided by the DUT. If not, the bit clock can be extracted from the CLOCK output connector (only with **Custom Dig Mod** signals in realtime). If signals complying with other digital standards are generated or if ARB waveforms are used, a marker signal can be used as a clock. As the DUT causes a delay, the ratio of clock-to-data travel times must always be taken into account and checked with an oscilloscope if necessary. The R&S **SMJ** indicates the status of the clock and data lines and of the synchronization in the menus.

### Ending the measurement

The measurement results usually lie in the range of  $10^{-2}$  to  $10^{-9}$  for the bit error rate, and in the range of  $10^{-2}$  to  $10^{-4}$  for the block error rate. This means that a very large number of bits or blocks may have to be tested before a faulty bit or block occurs. Because of the large number of bits/blocks involved, the measurement time is usually very long. Since 32-bit-wide counters are used for the total number of bits/blocks and the number of error bits, the maximum measurement time is  $4.29 \times 10^9$  bits.

To keep the measurement times short for both small and large bit/block error rates, the R&S Vector Signal Generator provides a number of ways to end the measurement. In addition to manually interrupting the count, two termination criteria can be selected: 1) reaching a user-defined number of checked data bits/blocks; 2) a maximum number of detected errors. The measurement stops as soon as one of the two criteria has been met. The display shows which of the two criteria caused the measurement to stop.

---

#### Note:

*The BER/BLER measurement measures statistical bit/block errors, i.e. errors which do not occur at regular intervals but at random. Although a single measurement determines the exact number of errors in the measured interval, a statistically reliable BER/BLER can only be obtained when a sufficient number of errors occurs in the observed interval. This is the only way to ensure that the single BER/BLER measurement result approaches the true error rate with high probability.*

*Bit error rates of approximately 50 % indicate a faulty measurement.*

---

### Interrupt-free measurement – bit error rate measurement

In the case of continuously generated signals that contain whole-number multiples of the PRBS sequence, the measurement occurs without interruption. Only the data and clock lines of the BERT interface are used for the measurement. The length of the random sequence is 2 to the power of the degree of the polynomial minus 1. For example, PRBS9 has a length of 511 ( $2^9$  equals 512 minus 1).

**Restart function – bit error rate measurement**

The **Restart** function makes it possible to perform BER measurements with short signals or with signals that are not continuously generated (and therefore do not contain any whole-number multiples of PRBS sequences). An external signal at the BERT input halts the measurement and restarts it when the data sequence begins, and the BER results of the relevant (sub)sequences are integrated.

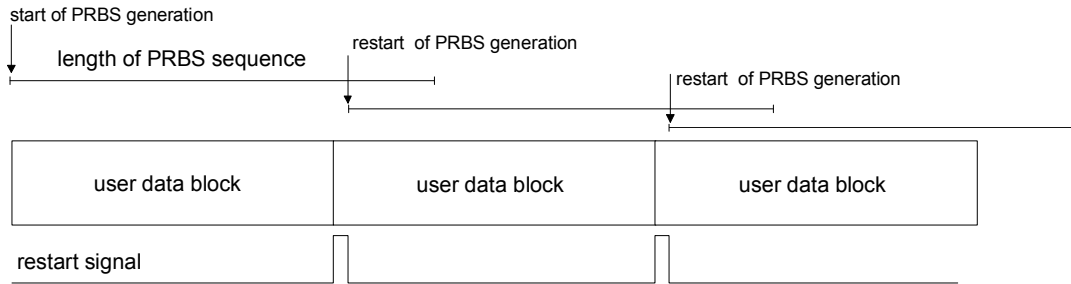

Fig. 4-2 The length of the signal is too short for a complete PRBS sequence; PRBS generation is restarted by the **Restart** signal when the signal begins anew.

Frames generated by the R&S Vector Signal Generator or the **WinIQSIM** software contain continuous PRBS data, i.e. the PRBS sequence is continuously written to the user data fields. Consequently, if the R&S Vector Signal Generator is used as a data source, a restart is only necessary if (e.g. when using a waveform) the total length of the signal does not equal a whole-number multiple of a PRBS sequence.

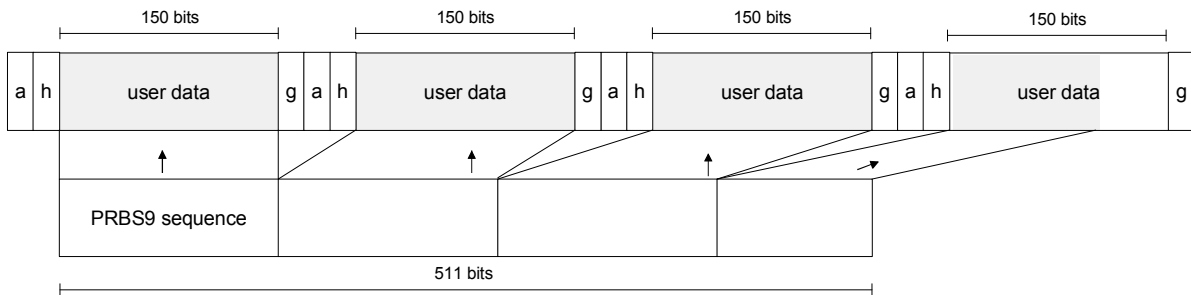

Fig. 4-3 TDMA signal generated by the R&S Vector Signal Generator with user data that contains the PRBS data sequence. The PRBS sequence is continuously written to the user data fields.

**Data Enable**

In the case of the **bit error rate measurement**, the data signals usually contain not only PRBS data but also other data (e.g. sync and preambles, see figure) that would result in bit errors. The BER measurement for this data can then be interrupted using the **Data Enable** signal. The **Data Enable** signal is fed in at the BERT input.

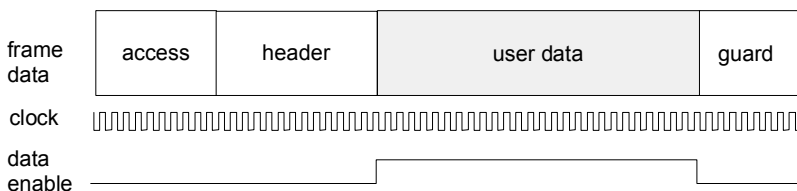

Fig. 4-4 TDMA signal with user data that contains the PRBS data sequence and various check fields which should be ignored for the bit error rate measurement. Below that are the associated clock and **Data Enable** signals.



In the case of the **block error rate measurement**, the **Data Enable** signal masks the user data (see following figure).

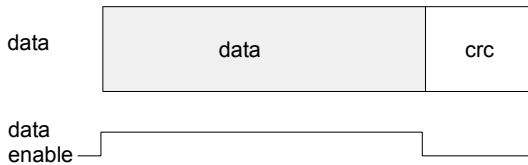

Fig. 4-5 **Data Enable** signal with block error rate measurement.

**Pattern Ignore – bit error rate measurement**

Bit sequences of 32 bits or more with only "1" or "0", which some mobile radio standards provide instead of frame data when faulty frames are detected, can also be excluded from the measurement using the **Pattern Ignore** function (see figure).

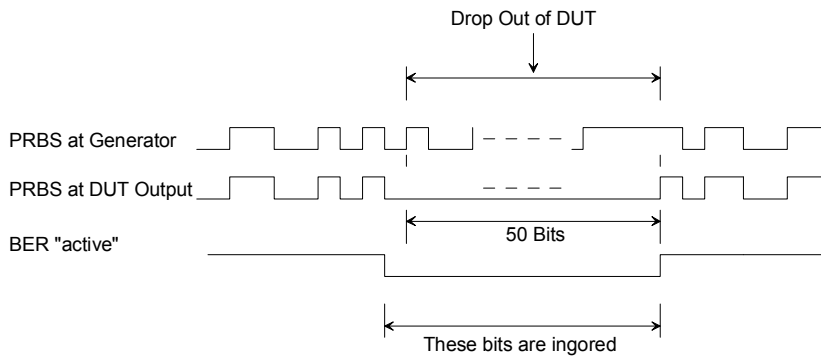

Fig. 4-6 Example of functionality of **Pattern Ignore**: 50 bits were set to "0" by the DUT. These 50 bits plus the preceding "0" are ignored in the bit error rate measurement.

# Bit Error Rate Menu

The **Bit Error Rate** menu for configuring the bit error rate measurement is called either in the **BERT** function block or via the **MENU** button under **BERT**.



The **Bit Error Rate** menu is divided into the following sections:



The top section is used to switch on the bit error rate measurement and display the results and current status of the measurement.

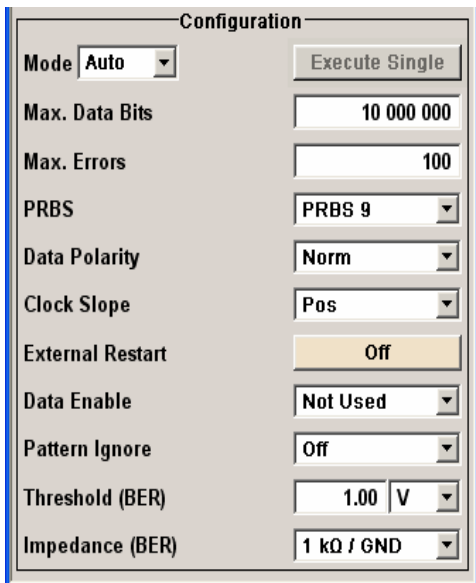

The **Configuration** section is used to select the type of measurement the data source and the termination criteria.

If the data is not cyclically continued, the measurement can be selectively interrupted and restarted. Certain data sections and frames that have been marked as faulty can be excluded from the measurement.

The top section is used to switch on the bit error rate measurement and display the results and current status of the measurement.

### State - Bit Error Rate

Switches the bit error rate measurement on/off.

Depending on the selection in the **Mode** box, either a continuous measurement (**Auto**) or a single measurement (**Single**) is carried out. A single measurement must be started by clicking the **Execute Single** button.

Remote-control command:  
BERT:STAT ON

**Bit Error Rate - Bit Error Rate**

Displays the measured bit error rate.

The bit error rate is the ratio of occurred errors to transmitted data bits.

Remote-control command:

BERT:RES?

Response (the 3rd value indicates the error rate):

"1000,5,5E-4,1,1,1,1"

The display unit can be selected in the box to the right of the value.

**ENG**

The bit error rate is output in exponential notation with the exponent  $-3$  or  $-6$ .

Remote-control command:

BERT:UNIT ENG

**SCI**

The bit error rate is output in scientific notation, i.e. standardized to one place to the left of the decimal.

Remote-control command:

BERT:UNIT SCI

**%**

The bit error rate is output in percent.

Remote-control command:

BERT:UNIT PCT

**ppm**

The bit error rate is output in parts per million.

Remote-control command:

BERT:UNIT PPM

**Data Bits – Bit Error Rate**

Displays the current number of data bits checked.

Remote-control command:

BERT:RES?

Response (the 1st value indicates the number of data bits checked):

"1000,5,5E-4,1,1,1,1"

**Errors – Bit Error Rate**

Displays the current number of occurred errors.

Remote-control command:

BERT:RES?

Response (the 2nd value indicates the number of occurred errors):

"1000,5,5E-4,1,1,1,1"

**Terminated By – Bit Error Rate**

Displays the termination criterion for the measurement.  
 These criteria can be entered to keep the duration of the measurement short for low as well as high bit error rates.  
 The last measurement result is displayed after the measurement has been terminated.  
 Remote-control command:  
 BERT:RES?  
 Response (the 4th value indicates whether the measurement has been terminated: 1 = terminated): "1000, 5, 5E-4, 1, 1, 1"

**User**                      The measurement was manually terminated by the user switching the state to off.  
 Remote-control command:  
 BERT:STAT OFF  
 BERT:STOP

**Number of Data Bits**      The measurement was terminated because the specified number of data bits was reached.

**Number of Errors**        The measurement was terminated because the specified number of errors was reached.

**State – Bit Error Rate**

Displays the status of the measurement.  
 This enables the user to check whether the measurement functions. The status of the data and clock lines and of synchronization is checked and displayed.  
 If a faulty status is displayed, the signals can be checked at the BERT interface using an oscilloscope.  
 Remote-control command:  
 BERT:RES?  
 Response (the 4th value indicates whether the measurement has been terminated: 1 = terminated): "1000, 5, 5E-4, 1, 1, 1"

**Clock**                      The applied clock signal was detected.  
 Remote-control command:  
 BERT:RES?  
 Response (the 5th value indicates the status of the clock line: 1 = active, 0 = not active):  
 "1000, 5, 5E-4, 1, 1, 1"

**No Clock**

The applied clock signal was not detected.

Possible causes are:

- Clock recovery is not available (e.g. with tests of RF components).  
If the signal is generated using the R&S Vector Signal Generator, the bit clock can be extracted from the CLOCK output connector (only with **Custom Dig Mod** signals in realtime).  
  
If signals complying with other digital standards are generated or if ARB waveforms are used, a marker signal can be used as a clock. As the DUT causes a delay, the ratio of clock-to-data travel times must always be taken into account and checked with an oscilloscope if necessary.
- The wrong impedance for the applied clock rate was selected (see **Impedance** parameter).
- The wrong threshold for the applied clock signal was selected (see **Threshold**).

**Data**

The applied data signal was detected.

Remote-control command:

BERT:RES?

Response (the 6th value indicates the status of the data line: 1 = active, 0 = not active):

"1000,5,5E-4,1,1,1,1"

**No Data**

The applied data signal was not detected.

Only clocked-in signals are detected; if the clock signal is missing, then data changes will also not be detected.

If the data is not detected despite the detected clock signal, this may be caused by the following:

- The signal from the DUT is missing.
- The wrong impedance for the applied clock rate was selected (see **Impedance** parameter).
- The wrong threshold for the applied data signal was selected (see **Threshold** parameter).

**Sync**

The measurement is synchronized.

Remote-control command:

BERT:RES?

Response (the 7th value indicates the status of the synchronization: 1 = successful, 0 = unsuccessful):

"1000,5,5E-4,1,1,1,1"

**No Sync**

The measurement is not synchronized.

Generally, a measurement cannot be synchronized until a clock and a data signal have been detected. If synchronization still does not occur, this may be caused by the following:

- The selected PRBS is not correct. For the bit error rate measurement, the PRBS sequence on which the data is based must be set on the bit error rate tester. If the PRBS is not correct, the BER measurement cannot synchronize to the data (due to the incorrect polynomial).
- A wrong clock slope is used, which violates setup or hold times (see **Clock Slope** parameter).
- The travel times of clock and data are unfavorable (e.g. clock slope at data change). Check the relationship of clock to data using an oscilloscope and optimize the travel times (e.g. clock slope when the data signal applied is stable).
- Reflections on the clock line occur, clocking the data signal into the BER measurement twice, e.g. on lines without termination. The R&S Vector Signal Generator input is **not** terminated.
- Incorrect polarity of data signal (or **Data Enable** signal).  
In this case the PRBS cannot synchronize. Note that an inversion of the output signal specified for some cases by the PRBS standard is performed automatically upon PRBS selection. Manual inversion of the data signal is therefore not required.

**No Sync status and an error rate of approx. 50%:**

1. A bit error occurs during synchronization (e.g. nine data bits with PRBS9). The BER measurement is set up incorrectly. This fault is internally detected and automatically corrected.
2. If data that is not cyclically continued (i.e. when a break in the sequence occurs at the memory wrap-around), the measurement will not be started at the right time.  
The signal on the **Restart** line enables the measurement to be started optimally at the beginning of the sequence.

The **Configuration** section is used to select the type of measurement, the data source and the termination criteria. If the data is not cyclically continued, the measurement can be selectively interrupted and restarted. Certain data areas and frames that have been marked as faulty can be excluded from the measurement.

**Mode - Bit Error Rate** Selects the type of measurement: single or continuous measurement.

**Auto** Continuous measurement of bit error rate.

If either or both of the termination criteria are met, the measurement in progress is terminated and immediately a new one is started automatically. Depending on the settings made, a measurement may take considerable time. During the first measurement, intermediate results are displayed. For the measurements that follow, only the final results are shown. The parameters **Data Bits** and **Errors** are continuously updated and indicate the relative values for the measurement in progress.

Remote-control command:

```
BERT:SEQ AUTO
```

**Single** Single measurement of bit error rate. The measurement is started by clicking the **Execute Single** button.

If a measurement is in progress, the current values for **Bit Error Rate**, **Errors** and **Data Bits** are cyclically displayed. The measurement is terminated when either or both of the termination criteria have been reached. To start a new measurement, the **Execute Single** button must be clicked again.

Remote-control command:

```
BERT:SEQ SING
:TRIG:BERT
```

**Max Data Bits – Bit Error Rate** Enter the number of transmitted data bits to be checked before the measurement is terminated.

This criterion terminates the BER measurement after the specified number of data bits, even if very few errors or none at all have been detected. With a low number of bit errors, the measurement result may be statistically unreliable.

If the measurement is terminated because the number of data bits entered here were checked, **Number of Data Bits** appears to the right of **Terminated By**.

Data excluded from the measurement by **Data Enable** or **Pattern Ignore** is not counted.

Remote-control command:

```
BERT:SET:MCO 1000
```

**Max Errors – Bit Error Rate** Enter the number of bit errors to occur before the measurement is terminated.

This criterion terminates the measurement relatively quickly if the error rate is high. The measurement result is statistically reliable, since many errors were already counted.

If the measurement is terminated because the number of bit errors entered here was reached, **Number of Errors** appears to the right of **Terminated By**.

Remote-control command:  
BERT:SET:MERR 1E4

**PRBS – Bit Error Rate** Selects the PRBS sequence. The data generated by the PRBS generator is used as a reference for the measurement.

---

**Note:**  
*Standard-compliant data inversion for PRBS15 and PRBS23 is performed automatically when the PRBS is selected. Data Polarity remains unaffected.*

---

Remote-control command:  
BERT:SET:TYPE PRBS15

**Data Polarity – Bit Error Rate** Sets the polarity of the feedback data bits.

---

**Note:**  
*Standard-compliant data inversion for PRBS15 and PRBS23 is performed automatically when the PRBS is selected. Data Polarity remains unaffected.*

---

**Norm** High level stands for a logic 1, low level for a logic 0.

Remote-control command:  
BERT:SET:DATA NORM

**Inv** Low level stands for a logic 1, high level for a logic 0.

Remote-control command:  
BERT:SET:DATA INV

**Clock Slope – Bit Error Rate** Sets the polarity of the active slope of the feedback clock.

**Pos** The positive slope of the clock signal is active.

Remote-control command:  
BERT:SET:CLOC RIS

**Neg** The negative slope of the clock signal is active.

Remote-control command:  
BERT:SET:CLOC FALL



- Impedance – Bit Error Rate** Sets the input impedance of the BERT inputs **Clock**, **Data**, **Data Enable** and **Restart**.  
For high clock rates, 50 Ohms should be selected.  
Remote-control command:  
SOUR:INP:BERT:IMP G50
- Threshold – Bit Error Rate** Sets high/low threshold in volts for the BERT inputs **Clock**, **Data**, **Data Enable** and **Restart**.  
The variable threshold makes it possible to align the BERT interface with the level of different input signals. In addition, reflections and other interference can be suppressed by selecting the appropriate threshold.  
Remote-control command:  
SOUR:INP:BERT:THR 1.0
- External Restart – Bit Error Rate** Activates/deactivates an external restart of the BER measurement.
- On** The reset signal for the BER measurement is fed via the **Restart** input of the BERT interface.  
If the PRBS cannot be continued uninterruptedly, the BER measurement must be stopped at the end of the data sequence and subsequently restarted at the beginning of the new data sequence. The measurement is stopped and started via a 0-1-0 slope of the restart signal. A transition from logic 0 to 1 causes a partial result to be generated and the measurement to be stopped. A transition from 1 to 0 starts the measurement for the next subinterval. This measurement is synchronized anew.  
If the R&S Vector Signal Generator is used as a data source, a signal in which a single 1 was coded at the end of the data sequence can be used as a restart signal at the R&S Vector Signal Generator marker output. This causes the BER measurement to stop briefly at the end of the data sequence and start again.  
Partial results (number of data and error bits) are added up until the predefined total number of data or error bits is reached or exceeded.  
The measurement is reset by **Pattern Ignore** or **Data Enable**, regardless of its status.  
Remote-control command:  
BERT:SET:REST:STAT ON
- Off** The reset signal for the BER measurement is generated internally.  
This setting is suitable for PRBS sequences that run continuously and thus ensure uninterrupted repetition.  
Remote-control command:  
BERT:SET:REST:STAT OFF

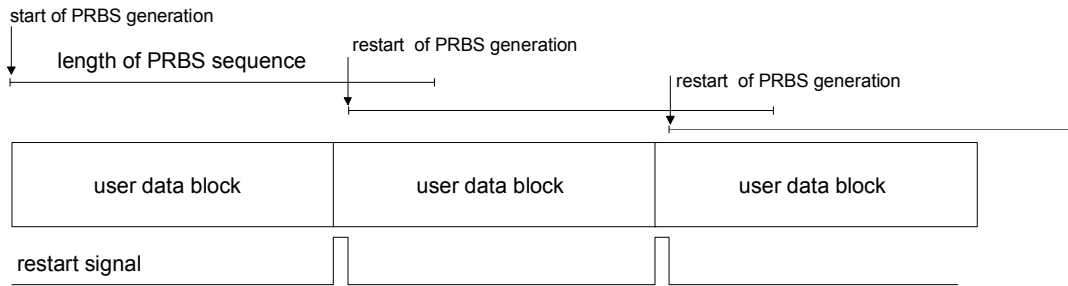

The length of the signal is too short for a complete PRBS sequence; PRBS generation is restarted by the **Restart** signal when the signal begins anew.

**Data Enable – Bit Error Rate**

Activates/deactivates the use of the **Data Enable** signal and sets the polarity of this signal if it is used.

The **Data Enable** signal marks the data that is actually to be evaluated for the BER measurement. Any data in addition to the PRBS sequence is masked and thus not evaluated (e.g. sync, preambles, other channels, etc that are present in the data bits supplied by the DUT).

The signal is fed in at the **Data Enable** input of the BERT interface. It is generated by the DUT but can also be provided by the R&S Vector Signal Generator in the form of a marker signal.

**Note:**

*If the data is not enabled, the BER measurement is stopped completely. The identification circuit for **Pattern Ignore** as well as the PRBS generator of the BER measurement wait as long as data is not enabled. If the data is enabled, the measurement is continued.*

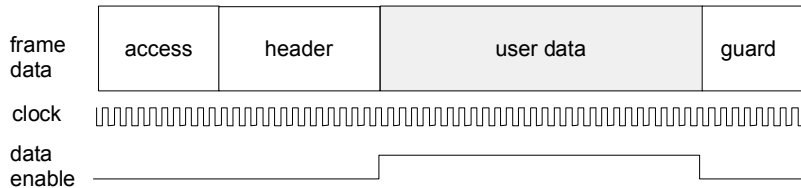

The figure shows a TDMA signal with user data that contains the PRBS data sequence and various check fields which should be ignored for the bit error rate measurement. Below that are the associated clock and **Data Enable** signals.

**Not Used**

Any signal at the **Data Enable** input is ignored; all data at the BERT data input is used for the measurement.

Remote-control command:  
BERT:SET:DEN OFF

**High**

The **Data Enable** signal is used. The only data measured is the data at the BERT data input during a high level of the **Data Enable** signal. The measurement is interrupted during a low level of the **Data Enable** signal.

Remote-control command:  
BERT:SET:DEN HIGH

**Low**

The **Data Enable** signal is used. The only data measured is the data at the BERT data input during a low level of the **Data Enable** signal. The measurement is interrupted during a high level of the **Data Enable** signal.

Remote-control command:

```
BERT:SET:DEN LOW
```

**Pattern Ignore – Bit Error Rate**

Activates/deactivates ignoring of pure "0" or "1" bit sequences at least 32 bits long. Activating **Pattern Ignore** excludes faulty frames from the measurement.

In the case of some mobile radio standards, pure "0" or "1" bit sequences are generated when errors (e.g. an incorrect checksum) are detected within a frame. These sequences, instead of the frame data, are provided for the BER measurement and signal that the frame in question should not be used for the measurement.

The R&S Vector Signal Generator ignores sequences of 32 bits or longer.

---

**Note:**

*While ignoring the bits, the PRBS generator for the BER measurement keeps running. Following the "0" or "1" sequence, the BER measurement is continued as if the ignored sequence had contained PRBS data.*

*If **Pattern Ignore** is switched on, synchronization time is 32 bits longer.*

*If **Pattern Ignore** and **External Restart** are active at the same time, the measurement terminates **immediately** when the restart signal is applied. None of the 32 bits within the **Pattern Ignore** detector is evaluated.*

*If **Data Enable** and **Pattern Ignore** are active at the same time, **Data Enable** is given priority, i.e. bits that are not enabled are not examined for "0" or "1" sequences.*

---

**Example:**

50 bits were set to "0" by the DUT. These 50 bits plus the preceding "0" are ignored in the bit error rate measurement.

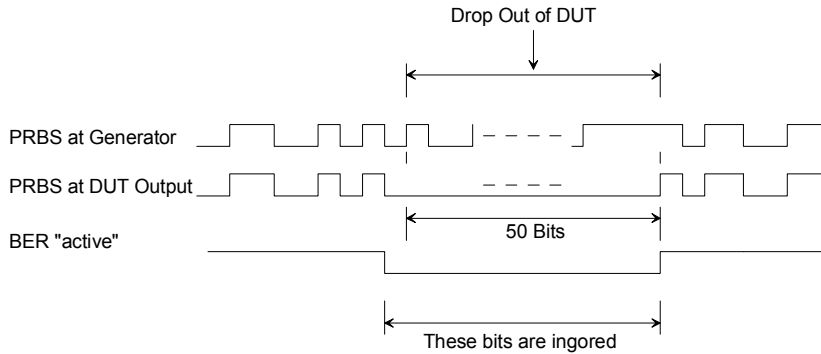

**Off**

**Pattern Ignore** is not active.

Remote-control command:  
BERT:SET:IGN OFF

**All 1**

Bit sequences consisting of 32 or more consecutive "1" data are not used (i.e. ignored) for the BER measurement.

Remote-control command:  
BERT:SET:IGN ONE

**All 0**

Bit sequences consisting of 32 or more consecutive "0" data are not used (i.e. ignored) for the BER measurement.

Remote-control command:  
BERT:SET:DEN ZERO

## Block Error Rate Menu

The **Block Error Rate** menu for configuring the block error rate measurement is called either in the **BERT** function block or via the **MENU** button under **BERT**.



The **Block Error Rate** menu is divided into the following sections:

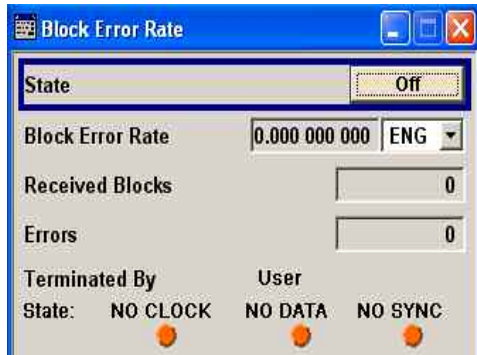

The top section is used to switch on the block error rate measurement and display the results and current status of the measurement.

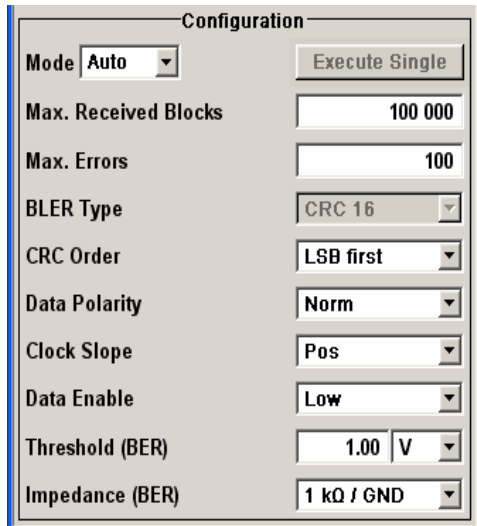

The **Configuration** section is used to select the type of measurement and the termination criteria and to set the polarity of the input signals.

The top section is used to switch on the block error rate measurement and display the results and current status of the measurement.

### State - Block Error Rate

Switches the block error rate measurement on/off.

Depending on the setting in the **Mode** box, either a continuous measurement (**Auto**) or a single measurement (**Single**) is carried out. A single measurement must be started by clicking the **Execute Single** button.

Remote-control command :

BLER:STAT ON

**Block Error Rate - Block Error Rate**

Displays the measured block error rate.

The block error rate is the ratio of faulty blocks to total blocks.

Remote-control command:

BLER:RES?

Response (the 3rd value indicates the error rate):

"1000,5,5E-4,1,1,1,1"

The display unit can be selected in the box to the right of the value.

**ENG**

The block error rate is output in exponential notation with the exponent  $-3$  or  $-6$ .

Remote-control command:

BLER:UNIT ENG

**SCI**

The block error rate is output in scientific notation, i.e. standardized to one place to the left of the decimal.

Remote-control command:

BLER:UNIT SCI

**%**

The block error rate is output in percent.

Remote-control command:

BLER:UNIT PCT

**ppm**

The block error rate is output in parts per million.

Remote-control command:

BLER:UNIT PPM

**Received Blocks – Block Error Rate**

Displays the current number of data blocks checked.

Remote-control command:

BLER:RES?

Response (the 1st value indicates the number of data blocks checked): "1000,5,5E-4,1,1,1,1"

**Errors – Block Error Rate**

Displays the current number of occurred errors.

Remote-control command:

BLER:RES?

Response (the 2nd value indicates the number of occurred errors):

"1000,6,5E-4,1,1,1,1"

**Terminated By – Block Error Rate**

Displays the termination criterion for the measurement.

These criteria can be entered to keep the duration of the measurement short for low as well as high block error rates.

The last measurement result is displayed after the measurement has been terminated.

Remote-control command:

BLER:RES?

Response (the 4th value indicates whether the measurement has been terminated: 1 = terminated): "1000, 5, 5E-4, 1, 1, 1"

**User**

The measurement was manually terminated by the user switching the state to off.

Remote-control command:

BLER:STAT OFF

BLER:STOP

**Number of Data Blocks**

The measurement was terminated because the specified number of data blocks was reached.

**Number of Errors**

The measurement was terminated because the specified number of errors was reached.

**State – Block Error Rate**

Displays the status of the measurement.

A green LED indicates a correct status, a red LED a critical status.

This allows the user to check whether the measurement functions. The status of the data and clock lines and of synchronization is checked and displayed.

If a faulty status is displayed, the signals can be checked at the BERT interface using an oscilloscope.

Remote-control command:

BLER:RES?

Response (the 4th value indicates whether the measurement has been terminated: 1 = terminated): "1000, 5, 5E-4, 1, 1, 1"

**Clock**

The applied clock signal was detected.

Remote-control command:

BLER:RES?

Response (the 5th value indicates the status of the clock line: 1 = active, 0 = not active):

"1000, 5, 5E-4, 1, 1, 1"

**No Clock**

The applied clock signal was not detected.

Possible causes are:

- Clock recovery is not available (e.g. with tests of RF components).  
If the signal is generated using the R&S Vector Signal Generator, the bit clock can be extracted from the CLOCK output connector (only with **Custom Dig Mod** signals in realtime). If signals complying with other digital standards are generated or if ARB waveforms are used, a marker signal can be used as a clock. As the DUT causes a delay, the ratio of clock-to-data travel times must always be taken into account and checked with an oscilloscope if necessary.
- The wrong impedance for the applied clock rate was selected (see **Impedance** parameter).
- The wrong threshold for the applied clock signal was selected (see **Threshold** parameter).

**Data**

The applied data signal was detected.

Remote-control command:

BLER:RES?

Response (the 6th value indicates the status of the data line: 1 = active, 0 = not active):

"1000,5,5E-4,1,1,1,1"

**No Data**

The applied data signal was not detected.

Possible causes are:

- The signal from the DUT is missing.
- The wrong impedance for the applied clock rate was selected (see **Impedance** parameter).
- The wrong threshold for the applied data signal was selected (see **Threshold** parameter).

**Sync**

The measurement is synchronized.

Remote-control command:

BLER:RES?

Response (the 7th value indicates the status of the synchronization: 1 = successful, 0 = unsuccessful):

"1000,5,5E-4,1,1,1,1"



**No Sync**

The measurement is not synchronized.

Generally, a measurement cannot be synchronized until a clock and a data signal have been detected. If synchronization still does not occur, this may be caused by the following:

- A wrong clock slope is used, which violates setup or hold times (see **Clock Slope** parameter).
- Reflections on the clock line occur and clock the data signal into the BER measurement twice, e.g. on lines without termination. The R&S Vector Signal Generator input is **not** terminated.
- The travel times of clock and data are unfavorable (e.g. clock slope with data change).

Check the relationship of clock to data using an oscilloscope and optimize the travel times (e.g. clock slope when the data signal applied is stable).

The **Configuration** section is used to select the type of measurement and the termination criteria and to set the polarity of the input signals.

**Mode - Block Error Rate**

Selects the type of measurement: single or continuous measurement.

**Auto**

Continuous measurement of block error rate.

If either or both of the termination criteria are met, the current measurement is terminated and immediately a new one is started automatically. Depending on the settings made, a measurement may take considerable time. During the first measurement, intermediate results are displayed. For the measurements that follow, only the final results are shown. The parameters **Received Blocks** and **Errors** are continuously updated and indicate the relative values for the measurement in progress.

Remote-control command:

```
BLER:SEQ AUTO
```

**Single**

Single measurement of bit error rate.

The measurement is started by clicking the **Execute Single** button.

If a measurement is in progress, the current values for **Block Error Rate**, **Errors** and **Received Blocks** are cyclically displayed. The measurement is terminated when either or both of the termination criteria have been reached. To start a new measurement, the **Execute Single** button must be clicked again.

Remote-control command:

```
BLER:SEQ SING
:TRIG:BLER
```

<b>Max Received Blocks – Block Error Rate</b>	<p>Enter the number of transmitted data blocks to be checked before the measurement is terminated.</p> <p>This criterion will terminate the BLER measurement after the specified number of data blocks, even if very few errors or none at all have been detected. With a low number of block errors, the measurement result may be statistically unreliable.</p> <p>If the measurement is terminated because the number of data blocks entered here were checked, <b>Number of Data Blocks</b> appears to the right of <b>Terminated By</b>.</p> <p>Remote-control command: BLER:SET:MCO 1000</p>
<b>Max Errors – Block Error Rate</b>	<p>Enter the number of block errors to occur before the measurement is terminated.</p> <p>This criterion terminates the measurement relatively quickly if the error rate is high. The measurement result is statistically reliable, since many errors were already counted.</p> <p>If the measurement is terminated because the number of block errors entered here was reached, <b>Number of Errors</b> appears to the right of <b>Terminated By</b>.</p> <p>Remote-control command: BLER:SET:MERR 1E4</p>
<b>CRC Order - Block Error Rate</b>	<p>Selects the byte order of the checksum (CRC).</p> <p><b>LSB</b>                      The checksum starts with the least significant byte.</p> <p>Remote-control command: BLER:SET:CORD LSB</p> <p><b>MSB</b>                      The checksum starts with the most significant byte.</p> <p>Remote-control command: BLER:SET:CORD MSB</p>
<b>BLER Type – Block Error Rate</b>	<p>Displays the CRC polynomial used. CCITT CRC 16 : <math>G(x) = x^{16} + x^{12} + x^5 + x^1</math> is the CRC polynomial supported.</p> <p>Remote-control command: BLER:SET:TYPE? Response: 'CRC16 '</p>
<b>Data Polarity – Block Error Rate</b>	<p>Sets the polarity of the feedback data blocks.</p> <p>Remote-control command: BLER:SET:DATA:POL NORM</p>

<b>Clock Slope – Block Error Rate</b>	<p>Sets the polarity of the active slope of the feedback clock.</p> <p>Remote-control command: BLER:SET:CLOC:POL RIS</p>
<b>Impedance – Block Error Rate</b>	<p>Sets the input impedance of the BERT inputs <b>Clock</b>, <b>Data</b>, <b>Data Enable</b> and <b>Restart</b>.</p> <p>For high clock rates, 50 Ohms should be selected.</p> <p>Remote-control command: SOUR:INP:BERT:IMP G50</p>
<b>Threshold – Block Error Rate</b>	<p>Sets high/low threshold in volts for the BERT inputs <b>Clock</b>, <b>Data</b>, <b>Data Enable</b> and <b>Restart</b>.</p> <p>The variable threshold makes it possible to align the BERT interface with the level of different signals. In addition, reflections and other interference can be suppressed by selecting the appropriate threshold.</p> <p>Remote-control command: SOUR:INP:BERT:THR 1.0</p>
<b>Data Enable – Block Error Rate</b>	<p>Sets the polarity of the <b>Data Enable</b> signal.</p> <p>The <b>Data Enable</b> signal marks the user data of the signal.</p> <p>The signal is generated by the DUT and fed in at the <b>Data Enable</b> input of the BERT interface.</p> <p><b>High</b></p> <p>If the <b>Data Enable</b> signal is at a high level, the data bits at the BERT data input are interpreted as user data. During a low level of the <b>Data Enable</b> signal, they are interpreted as checksum bits.</p> <p>Remote-control command: BLER:SET:DEN HIGH</p> <p><b>Low</b></p> <p>If the <b>Data Enable</b> signal is at a low level, the data bits at the BERT data input are interpreted as user data. During a high level of the <b>Data Enable</b> signal, they are interpreted as checksum bits.</p> <p>Remote-control command: BLER:SET:DEN LOW</p>

# RF Signal and Analog Mod - A Mod-RF A

## Overview of RF Signal and Analog Modulations

Settings for the RF output signal and analog modulation are made under "RF Signal and Analog Modulations". These settings can be accessed in the block diagram by way of the **RF/A MOD** function block, or by means of the menu with the same name which is opened using the **MENU** key.

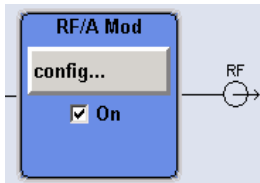

The function block is available for the basic unit (R&S SMJ-B10x) without additional equipment options.

The RF output signal can be activated and deactivated directly using the **TOGGLE ON/OFF** key, the function block must be highlighted beforehand).

The **RF ON/OFF** key can also be used to activate and deactivate the output signal (here, however, the current entry focus is irrelevant).

Remote-control commands:

OUTP:STAT OFF

The activated and deactivated state is indicated in the block diagram by means of the different block color and the status of the **On** checkbox. The disconnected connection to the output is additionally shown when the output is deactivated. Active analog modulation is also indicated in the block.

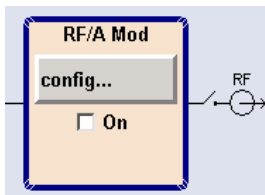

The RF output state can also be set in the **Configure** menu of the RF /MOD block.

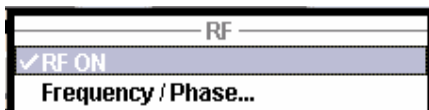

Remote-control command:

OUTP:STAT OFF

The CW, Sweep and List modes are available for generating the RF signal.

**CW** The RF signal is generated with the set frequency and level. This is the default mode.

**Sweep** The RF signal is generated as a sweep with the set parameters.  
It is not possible to activate frequency, level and LF sweep simultaneously.

**List Mode** The RF signal is generated on the basis of a list of predefined frequency and level values. The duration of the individual steps can be predefined.

Instruments connected downstream can be taken into consideration when setting the frequency and level by entering a frequency and/or level offset.

Automatic level control ensures maximum level accuracy, even with I/Q modulation.

User-specific lists which contain level correction values for any frequency range (User Correction) can be created to, for example, compensate the cable attenuation in a test assembly setup.

The RF signal can be generated in unmodulated or analog form. An internal LF generator and/or the external modulation input EXT MOD at the rear of the instrument is available as the source for the analog modulations.

An external trigger signal for the analog modulations, the sweeps and the LIST mode can be provided at the two INST TRIG inputs. The input REF IN is used to input an external instrument reference, and the output REF OUT serves as the output of the reference frequency (internal or external).

## RF Frequency and Phase - Frequency - Phase

The simplest way to set the RF frequency is to enter it directly in the header of the display.



The entry is activated by pressing the **[FREQ]** key. Changes to the frequency have an immediate effect (without confirmation with the Enter key) on the output signal.

Remote-control command

SOUR:FREQ 100 MHz

### Note:

The IEC/IEEE-bus command sets the level of the **Freq** display, i.e. an entered frequency offset is taken into consideration in the frequency value (see below).

The frequency entered and displayed in the frequency field takes any set frequency offset into consideration, e.g. an offset set for a downstream instrument. This means that with a frequency offset the frequency displayed in the header does not correspond to the frequency at the RF output, but rather to the frequency at the output of the downstream instrument. A set frequency offset is indicated by the **FREQ OFFSET** status message.

This allows the desired frequency at the output of a downstream instrument to be entered in the frequency field. The R&S Vector Signal Generator changes the RF output frequency according to the entered offset.

However, the frequency entered and displayed in the **Frequency/Phase** menu of the **RF/Ana Mod** function block always corresponds to the RF output frequency. Any frequency offset is not taken into consideration.

The correlation is as follows:

**Freq in header = RF output frequency (= Freq in menu) + Freq offset (= Offset in menu)**

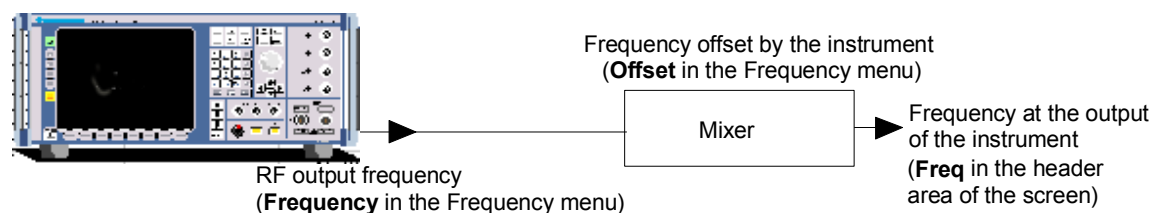

The frequency offset is entered in the **Frequency/Phase** menu. Here it is also possible to set the frequency without taking the offset into consideration, to set the step width for the frequency entry using the rotary knob, and to set the phase for the RF output signal.

## Frequency - Phase Menu

The **Frequency/Phase** menu is opened either in the **RF/A Mod** function block or using the **[MENU]** key under **RF/A Mod**.

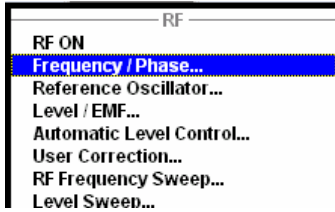

Frequency and phase of the RF output signal are set in the upper part of the group menu. Phase continuous frequency setting can be activated in the respective section. The lower parts concern the settings of the reference oscillator and are described in the section "[RF Reference Frequency - Reference Oscillator](#)", page 4.78.

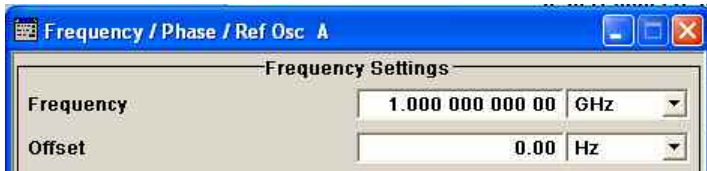

The frequency and offset are set in the top section of the menu.

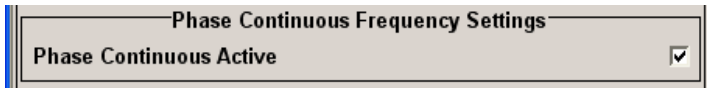

Enables frequency changes to be phase continuous in a certain frequency range.

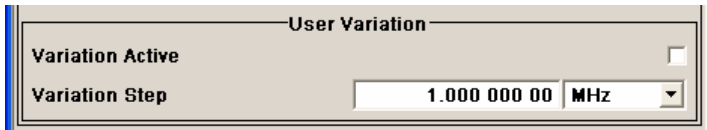

The step width which is used when setting the frequency using the rotary knob (with **Variation Active On**) is set in the **User Variation** section.

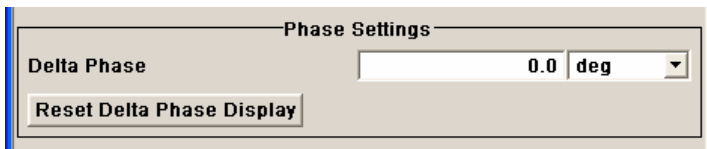

The phase of the output signal can be changed in the **Phase Settings** section.

The frequency and offset are set in the top section of the menu.

### Frequency - RF Signal

Sets the RF frequency of the RF output connector. The frequency entered and displayed here corresponds to the frequency at the RF output, i.e. any offset entry is not taken into consideration.

Remote-control command: n.a.

**Note:**

The IEC/IEEE-bus command `SOUR:FREQ` sets the frequency of the **FREQ** display, i.e. the frequency containing offset.

**Frequency Offset - RF Signal**

Sets the frequency offset relative to the RF frequency. The frequency offset of a downstream instrument (e.g. a mixer) is entered.

The entry does not change the value of the RF frequency at the RF output. It only changes the RF frequency displayed in the display header. The value of the RF frequency in the header corresponds to the frequency.

Remote-control command:  
SOUR:FREQ:OFFS 0 Hz

A phase continuous mode can be enabled in the **Phase Continuous Frequency Settings** section (see following section "[Phase Continuous Frequency Setting](#)", on page 4.75).

If the frequency is set using the rotary knob, the step width is defined in the **User Variation** section.

**Variation Step - RF Signal**

Sets the user-defined step width. This step width is used when entering the RF frequency using the rotary knob. Frequency variation with this step width must also be activated with **Variation Active**.

Remote-control command:  
SOUR:FREQ:STEP 1 MHz

**Variation Active - RF Signal**

Activates the user-defined step width used when varying the frequency value with the rotary knob.

**ON**

The frequency value set with the rotary knob is varied using the user-defined step width which is entered under **Variation Step**.

Remote-control command:  
SOUR:FREQ:STEP:MODE USER

**OFF**

The frequency value set with the rotary knob is varied in steps of one unit at the cursor position (standard operating mode).

Remote-control command:  
SOUR:FREQ:STEP:MODE DEC

The phase of the RF output signal can be changed in the **Phase Settings** section.

**Delta Phase - RF Signal**

Sets the phase of the RF signal. The current phase of the signal is used as the reference. This function allows, for example, the phase of the output signal to be synchronized with the phase of a signal from a second signal generator.

Remote-control command:  
SOUR:PHAS 10 DEG

**Reset Delta Phase Display - RF Signal**

Resets delta phase value. The set phase is adopted as the new current phase, i.e. the delta phase value is reset to 0.

Remote-control command:  
SOUR:PHAS:REF



## Phase Continuous Frequency Setting

The phase continuous mode can be enabled in the **Phase Continuous Frequency Settings** section of the **Frequency** menu. In this mode, the output sinewave is phase continuous, i.e. there is no phase discontinuity or glitch when changing the frequency.

At the transition from one frequency to another an intermediate frequency (switching transient) occurs, which causes spurs (see figure below). The transient is due to changes of the synthesizer settings (e.g. dividers, filters, phase detectors).

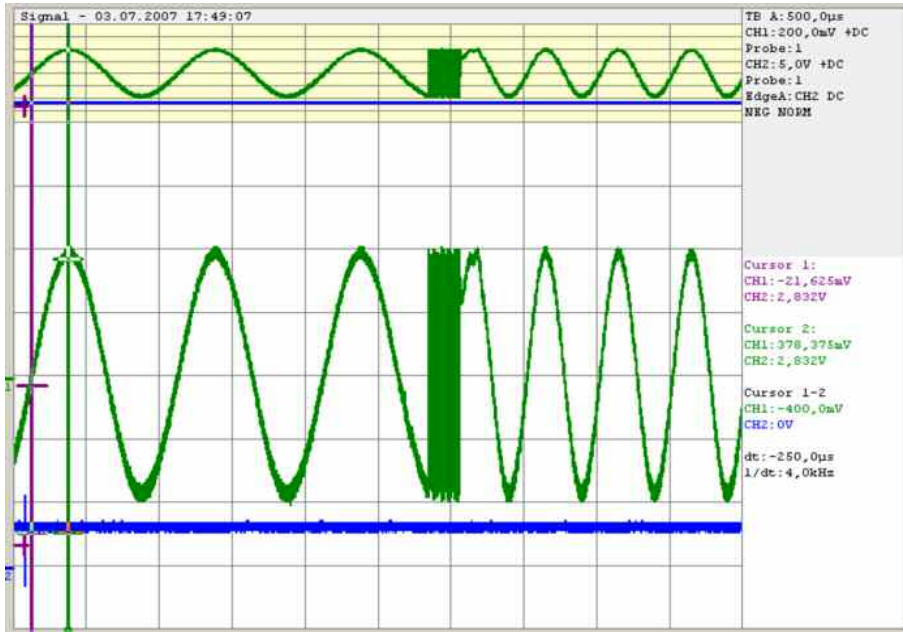

Figure 0-1: Transition for a 1 kHz step at 1 GHz without phase continuous mode active. For the graphical display the signal is down converted into the kHz range.

The phase continuous mode freezes the settings of the synthesizer (e.g. dividers, filters, phase detectors) which could generate phase discontinuities when changed. The frequency change is effectively performed by changing the fine resolution synthesizer. This allows a phase continuous change from one frequency to another without any transients (see figure below).

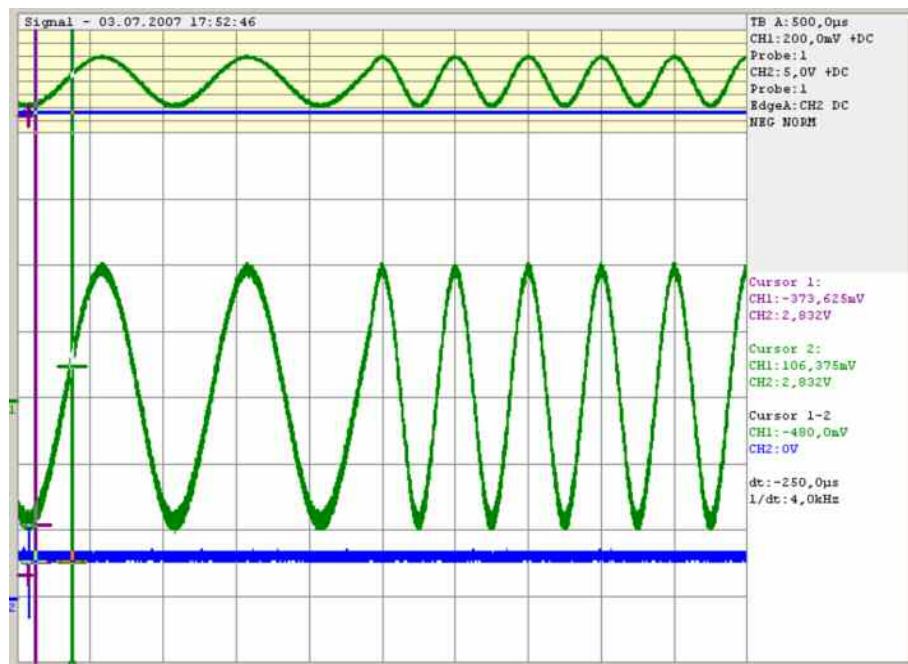

Figure 0-2: Transition for a 1 kHz step at 1 GHz with phase continuous mode active. For the graphical display the signal is down converted into the kHz range.

The available frequency range for phase continuous settings is limited by the fine resolution synthesizer used and varies with the RF frequency setting at the point of activating the phase continuous mode.

Depending on the instrument equipment - with or without option R&S SMx-B22 - the fine resolution synthesizer used is a DDS (Direct Digital Synthesizer, with option R&S SMx-B22) or a Fractional N-Synthesizer (without option R&S SMx-B22). The DDS provides generally a wider frequency range for phase continuous settings. In addition, two modes (narrow and wide) allow a selection either in favor of higher signal quality or in favor of an especially wide frequency range.

#### Notes:

*When phase continuous frequency setting is active, data sheet values no longer apply  
 Activating frequency or phase modulation deactivates phase continuous settings and vice versa.*

#### Setting a Phase Continuous Frequency Sweep

1. In the **RF Frequency Sweep** Menu, if the sweep is active, switch it off
2. In the **RF Frequency** Menu under the Phase Continuous Frequency Settings Menu
  - a. If the **Phase Continuous Frequency Mode** is Active, switch it off
  - b. Set Frequency Range to "Narrow"
  - c. Select the RF frequency
  - d. Check displayed Frequency Range
  - e. If the Frequency Range is corresponds with the selected frequency range, check the Phase Continuous Active box
  - f. If Frequency Range in Narrow Mode does not, select "Wide" for the Frequency Range and check the Phase Continuous Active box
3. In the **RF Frequency Sweep** Menu,
  - a. Modify the Start Freq and Stop Freq or Center Frequency and Span as needed.
  - b. Set the RF frequency sweep State to "ON".

**Optimum user settings for the phase continuous frequency sweep:**

In the **RF Frequency Sweep** Menu there are some settings that will improve the phase continuous sweep results for both **Narrow** and **Wide** mode choices.

- **Step Lin:** low step size  
In order to get the best spur performance during frequency change, it is recommended to reduce the step size and (if necessary) increase the sweep speed by decreasing the Dwell Time. Effectively, the sweep will be performed in the same amount of time, but with smaller step sizes.
- **Shape:** Triangle sweep  
The triangle sweep offers a uniform forward sweep and return to the beginning frequency. The saw tooth sweep produces a uniform forward sweep with an abrupt reset to the starting frequency. The abrupt reset can generate spurs.

The phase continuous settings are available in the middle section of the **Frequency** menu.

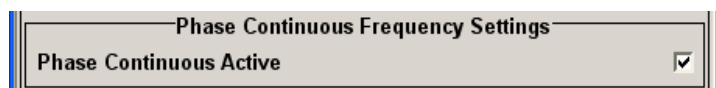

**Phase Continuous Active - RF Signal** - Activates/deactivates phase continuous frequency settings. For a given RF frequency setting, phase continuous frequency changes are possible in a limited frequency range:

The range is typically +/-0.5 MHz in the main synthesizer octave of 750 MHz to 1.5 GHz. For the tuning range of other frequencies see table below.

**Note:**

*If **Phase Continuous** is **Active** a setting of the **RF Frequency** outside the available **Frequency Range** causes an error. A settings conflict is displayed.*

Remote-control command:

SOUR:FREQ:PHAS:CONT:STAT ON

RF frequency [MHZ]	Typ . range
f <= 6.6	125 kHz
6.6 < f <= 11.71875	7.813 kHz
11.71875 < f <= 23.4375	15.625 kHz
23.4375 < f <= 46.875	31.25 kHz
46.875 < f <= 93.75	62.5 kHz
93.75 < f <= 187.5	125 kHz
187.5 < f <= 375	250 kHz
375 < f <= 750	500 kHz
750 < f <= 1500	1 MHz
1500 < f <= 3000	2 MHz
3000 < f <= 6000	4 MHz

## RF Reference Frequency - Reference Oscillator

In the internal reference mode the internal reference signal is available at the REF OUT connector (rear of instrument). The frequency of the internal reference signal is permanently set to 10 MHz. The frequency of the internal reference oscillator can be impaired by means of the EXT TUNE input (AUX I/Q connector at rear of instrument) (**Frequency Adjustment**; see data sheet for technical information). External impairment is possible in both **Adjustment State** states (**On** or **Off**).

In the external reference mode an external signal with selectable frequency and defined level must be input at the REF IN connector. This signal is output at the REF OUT connector. The **EXT REF** status message appears in the display header.

### Note:

The setting of the reference oscillator are not influenced by an instrument preset (PRESET key).

## Reference Oscillator Menu

The **Reference Oscillator** menu is opened either in the **RF/A Mod** function block or using the **MENU** key under **RF/A Mod**.

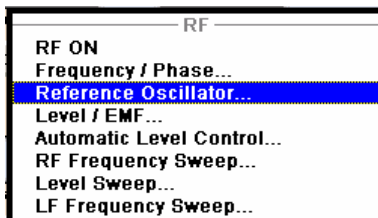

The reference oscillator is set in the lower areas of the group menu. The three upper areas are for setting the frequency and phase of the RF output signal; see section "RF Frequency and Phase - Frequency - Phase", page 4.72.



....

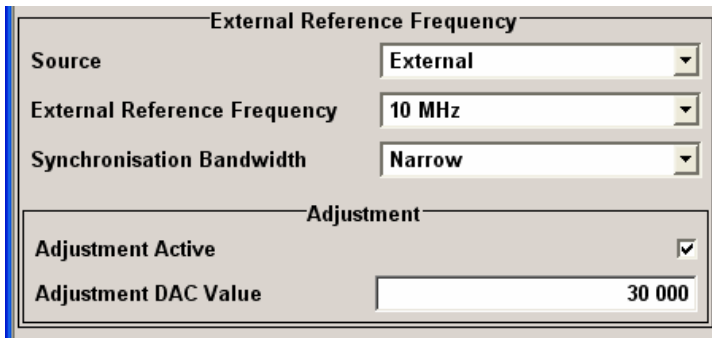

The menu is used to select the source, to enter the frequency of an external reference signal and to adjust the reference frequency.

### Source - Reference Oscillator

Selects the source of the reference frequency.

#### Internal

The internal reference signal of 10 MHz is used.

Remote-control command:

SOUR:ROSC:SOUR INT

	<b>External</b>	An external reference signal is used. The frequency of the external reference signal must be selected under <b>External Frequency</b> .  Remote-control command: SOUR:ROSC:SOUR EXT
<b>External Reference Frequency - RF Signal</b>		Selects the frequency of the external reference signal.  Remote-control command: SOUR:ROSC:EXT:FREQ 13E6
<b>Synchronization Bandwidth - RF Signal</b>		(Source External only) Selects the synchronization bandwidth for an external reference signal. The wideband setting is provided for using very good reference sources of high spectral purity.
	<b>Narrow</b>	Synchronization bandwidth is 1 Hz.  Remote-control command: SOUR:ROSC:EXT:SBAN NARR
	<b>Wide</b>	Synchronization bandwidth is 750 Hz.  Remote-control command: SOUR:ROSC:EXT:SBAN WIDE
<b>Adjustment Active - Reference Oscillator</b>		Selects adjustment mode.
	<b>OFF</b>	The calibrated adjustment value of the internal reference frequency is used. This value is determined at one of the R&S service shops during calibration.  Remote-control command: SOUR:ROSC:INT:ADJ:STAT OFF
	<b>ON</b>	A user-defined adjustment value is used. The value is entered under <b>Adjustment DAC Value</b> .  This allows the frequency to be impaired freely, for example to simulate a frequency error.  The instrument is no longer in the calibrated state. However, the calibration value is not changed and the instrument resumes the calibrated state after switching the Adjustment State to Off.  Remote-control command: SOUR:ROSC:INT:ADJ:STAT ON
<b>Adjustment DAC Value - RF Signal</b>		Enters a user-defined adjustment value for the internal reference frequency. This value is not used unless <b>Adjustment Active On</b> is selected.  Remote-control command: SOUR:ROSC:INT:ADJ:VAL 1400

## RF Level - Level - EMF

### Note:

The message **Level overrange/underrange** appears in the status line if the set level (**Level**) or the displayed peak envelope power (**PEP**) (Digital Modulation or Digital Standard) is in the overrange (see data sheet). The correct level setting cannot be guaranteed for the entire frequency range if the set level is in the overrange/underrange.

The simplest way to set the RF level is to enter it directly in the header of the display.



The entry is activated by pressing the **LEVEL** key. Changes to the level have an immediate effect (without confirmation with the Enter key) on the output signal.

Remote-control command:

```
SOUR: POW: LEV: IMM: AMPL -30 dBm
```

### Note:

The IEC/IEEE-bus command sets the level of the **Level** display, i.e. an entered level offset is taken into consideration in the level value (see below).

The center line (**Level**) and, to the left of this, the peak envelope power (**PEP**) of the modulated RF output signal is displayed in the case of digital modulation or digital standard.

dBm, dBμV, mV and μV can be used as the level units. The 4 unit keys are labeled with these units.

The level entered and displayed in the Level field takes the offset of any downstream attenuators/amplifiers into consideration by way of calculation. This means that with a level offset the level displayed in the header does not correspond to the level at the RF output, but rather to the level at the output of the downstream instrument.

This allows the desired level at the output of downstream instruments to be entered. The R&S Vector Signal Generator changes the RF output level according to the set offset.

However, the level entered and displayed in the **Level** menu of the **RF/Ana Mod** function block always corresponds to the RF output level. Any level offset is not taken into consideration.

The correlation is as follows:

**Level in header = RF output level (= Level in menu) + Level offset**

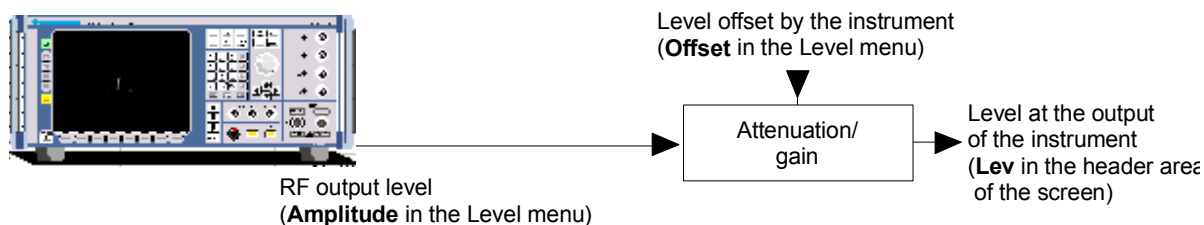

The level offset is entered in the **Level** menu. Here it is also possible to set the level without taking the offset into consideration, and to make other settings, such as level offset, attenuator mode, power-on state.

## Level - EMF Menu

The **RF Level - EMF** menu is opened either in the **RF/Ana Mod** function block or using the **MENU** key under **RF/Ana Mod**.

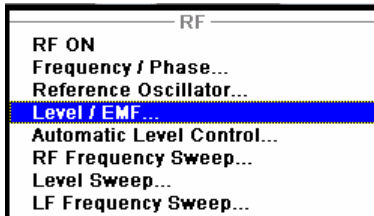

The top sections of the combined menu **Level / EMF / ALC /UCOR** provide access to the level and attenuator settings. The lower sections provide access to the automatic level control settings, see section "[Automatic Level Control - ALC](#)", page 4.84. and to function User Correction, see section "[User Correction](#)", page 4.92.

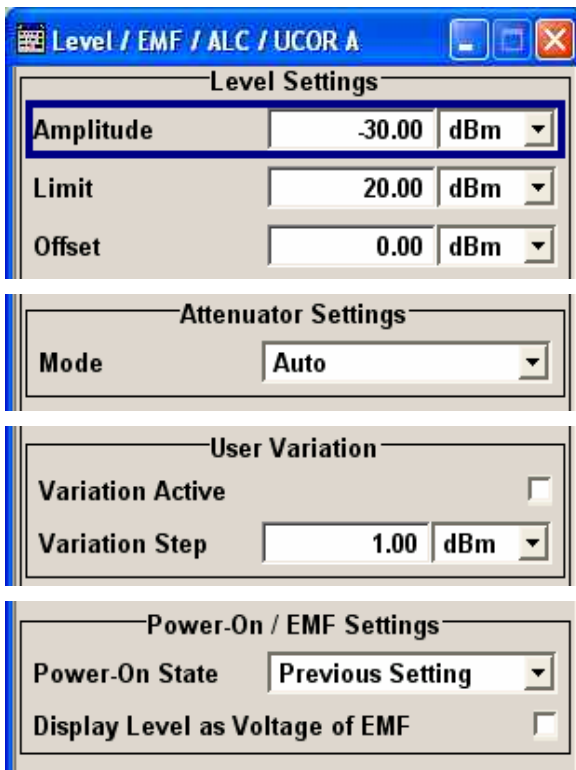

The offset-free level, attenuation mode, level offset and level limit are set in the top section of the menu.

The attenuator is set in the **Attenuator Settings** section.

The step width which is used when setting the level using the rotary knob (with **Variation Active On**) is set in the **User Variation** section.

The power-on behavior of the R&S Vector Signal Generator and the level display in the display header are set in the **Power-On / EMF Settings** section.

The offset-free level, attenuation mode, level offset and level limit are set in the top section of the menu.

### Amplitude - RF Signal

Sets the RF level of the RF output connector.

The level entered and displayed here corresponds to the level at the RF output, i.e. any offset entry is not taken into consideration.

Remote-control command: n.a.

**Note:**

The IEC/IEEE-bus command `SOUR:POW:LEV:IMM:AMPL` sets the level of the **Level display**, i.e. the level containing offset.

**Limit - RF Signal**

Sets the level limit.

The value specifies the upper limit of the level at the RF output connector. A message appears if an attempt is made to set a level above this limit and the level at the RF output is confined to the upper limit. However, the level indication is not influenced.

Remote-control command:

```
SOUR:POW:LIM:AMPL 30 dBm
```

**Offset (Level) - RF Signal**

Sets the level offset relative to the RF level.

The level offset of a downstream instrument (e.g. an attenuator or amplifier) is entered.

The entry does not change the value of the RF level at the RF output. It only changes the RF level displayed in the display header. The value of the RF level in the header corresponds to the level at the output of the downstream instrument.

Remote-control command:

```
SOUR:POW:LEV:IMM:OFFS 0
```

The attenuator mode is set in the **Attenuator Settings** section.

**Attenuator Mode - RF Signal**

Sets the attenuator mode at the RF output.

**Auto**

Standard mode. The electronically switching attenuator switches with a 5 dB step width at fixed switching points.

Remote-control command:

```
OUTP:AMOD AUTO
```

**Fixed**

The level settings are made without switching the attenuator and the high-power output option. When this operating mode is switched on, the attenuator and the option are fixed in their current positions and the resulting variation range is defined. The range is displayed under **Attenuator Fixed Range**.

If automatic level control is activated (**ALC State = On**), the level settings are made without interruption.

If the normal variation range is overranged or underranged, level errors increase considerably and the warning **Level under/overrange** appears in the info line. The spectral purity of the output signal decreases with high attenuation.

Remote-control command:

```
OUTP:AMOD FIX
```



**Fixed Range (PEP) In** Displays the level range in which the level is set without interruption for the "**Attenuator Mode fixed**" setting.

Remote-control commands:

OUTP:AFIX:RANG:UPP?

OUTP:AFIX:RANG:LOW?

If the level is set using the rotary knob, the step width is defined in the **User Variation** section.

**Variation Active - RF Level** Activates the user-defined step width used when varying the level value with the rotary knob.

**ON**

The level value set with the rotary knob is varied using the user-defined step width which is entered under **Variation Step**.

Remote-control command:

SOUR:POW:STEP:MODE USER

**OFF**

The level value set with the rotary knob is varied in steps of one unit at the cursor position (standard operating mode).

Remote-control command:

SOUR:POW:STEP:MODE DEC

**Variation Step - RF Level** Sets the user-defined step width for entering the RF level using the rotary knob. Level variation with this step width must also be activated with **Variation Active**.

Remote-control command:

SOUR:POW:STEP:INCR 1dBm

The power-on behavior of the R&S Vector Signal Generator and the level display in the display header are set in the **Power-On /EMF Settings** section.

**Power-On State - RF Signal** Selects the state which the RF output is to assume after the instrument is switched on.

**RF Off**

The output is deactivated when the instrument is switched on.

Remote-control command:

OUTP:PON OFF

**Previous Setting**

When the instrument is switched on, the output assumes the same state as it had when the instrument was switched off.

Remote-control command:

OUTP:PON ON

**Display Level as Voltage of EMF - RF Level** Activates display of the signal level as voltage of the EMF (no-load voltage). If this setting is deactivated, the level is displayed as a voltage over a 50 Ohm load (preset state).

Remote-control command: n.a.

## Automatic Level Control - ALC

Automatic level control (**Automatic Level Control**) can be used with almost all applications, especially I/Q modulation and amplitude modulation. It only has to be deactivated for certain settings in the baseband and when I/Q impairments (**Impairments State On**) are activated. This is indicated under the respective function.

The level control status is permanently displayed as a status message in the info line.

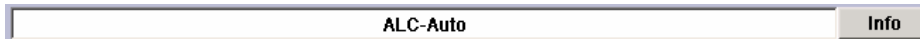

The standard operating status is level control **On**. This provides the highest level accuracy. The preset is **Auto**. In this mode the level control is automatically adapted to the operating conditions.

Level control can be switched to **Sample&Hold** or **On** for particular applications. The **Sample&Hold** state (level control Off) is recommended if in CW mode the signal/intermodulation ratio is to be improved for multi-transmitter measurements.

If **Sample&Hold** is selected, the level is recalibrated for every level and frequency setting. For this purpose, level control is activated briefly at a defined signal, the level adjuster is then held at the attained value and level control is activated.

If **On** and **Attenuator Mode Fixed** is selected, the level is recalibrated for every level and frequency setting. For this purpose, level control is activated briefly at a defined signal, the level adjuster is then held at the attained value and level control is activated the uninterrupted level settings are made.

## Automatic Level Control Menu

The **Automatic Level Control** menu is opened either in the **RF/A Mod** function block or using the **MENU** key under **RF/A Mod**.

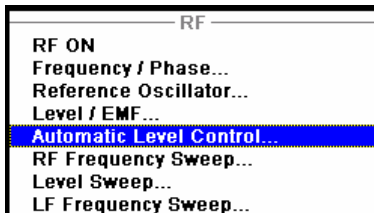

The combined menu Level / EMF / ALC /UCOR provides access to the automatic level control settings in the lower section. The top sections provide access to the level and attenuator settings, see section "[RF Reference Frequency - Reference Oscillator](#)", page 4.78, the bottom section to function User Correction, see section "[User Correction](#)", page 4.92.

### Note:

*External Level Control is possible using R&S NRP power sensors, see following section "[Power Sensors](#)", on page 4.86.*



This menu is used to activate level control.

**State - ALC**

Activates/deactivates internal level control.

**Off (Sample & Hold)**

Internal level control is deactivated.

Remote-control command:

```
SOUR:POW:ALC OFF
SOUR:POW:ALC:OMOD SHOL
```

**Auto**

Default state. Level control is automatically adapted to the operating states.

Remote-control command:

```
SOUR:POW:ALC AUTO
```

**On**

Internal level control is permanently activated.

Remote-control command:

```
SOUR:POW:ALC ON
```

**Search Once - ALC**

Manually activates level control briefly to allow the level to be calibrated (the **Sample&Hold** setting must be selected).

Remote-control command:

```
SOUR:POW:ALC:SONC
```

**Protect RF Output - ALC**

The signal is attenuated for about 40 dB to protect external devices against internal signals, if the following prerequisites are fulfilled:

- ALC state is On or AUTO
- High-Power Mode is Off
- I/Q Modulator is On
- Baseband is armed

Remote-control command:

```
OUT:PROT:STAT ON
```

## Power Sensors

Up to three R&S NRP power sensors can be connected to the generator. The SENSOR connector for the first R&S NRP power sensor is on the front panel, a second and third R&S NRP power sensor can be connected via the USB interfaces (front and rear panel, requires USB adapter R&S NRP-Z3 or R&S NRP-Z4). The connected R&S NRP power sensors are automatically detected and indicated in the **NRP-Z Power Viewer** menu.

The average signal power is continuously measured by the R&S NRP power sensor(s) and indicated in the Power Sensors menu (**NRP-Z Power Viewer**). Permanent display of the measurement results in the block diagram can be activated.

The output signals of the two RF signal paths (reference level is the set RF level) or any freely selectable source can be measured.

The signal generator supports the use of R&S NRP power sensors for the acquisition of level correction data. The acquired level correction data is used to create and activate lists in which level correction values predefined by the user are freely assigned to RF frequencies. Correction is performed by the user-defined table values being added to the output level for the respective RF frequency (see [User Correction](#), on page 4.92).

---

### Note:

*Please see your R&S NRP power sensor manual for detailed information on the used power sensor.*

---

## NRP-Z Power Viewer Menu

The **NRP-Z Power Viewer** menu is opened either in the **RF/A Mod** function block or using the **MENU** key under **RF/A Mod**. The menu is structured like a table showing the values for sensor 1 in the left "column" and the values of the second/third sensor in the middle/right "column". Only the detected sensors are indicated, i.e. if only one sensor is connected only one column is indicated. The sensor connected to the SENSOR port is always indicated as sensor 1, and the sensors connected to the USB interface are always indicated as sensor 2 and 3.

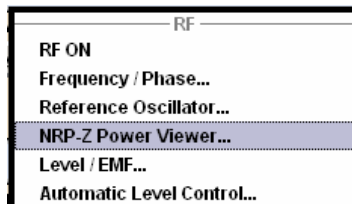

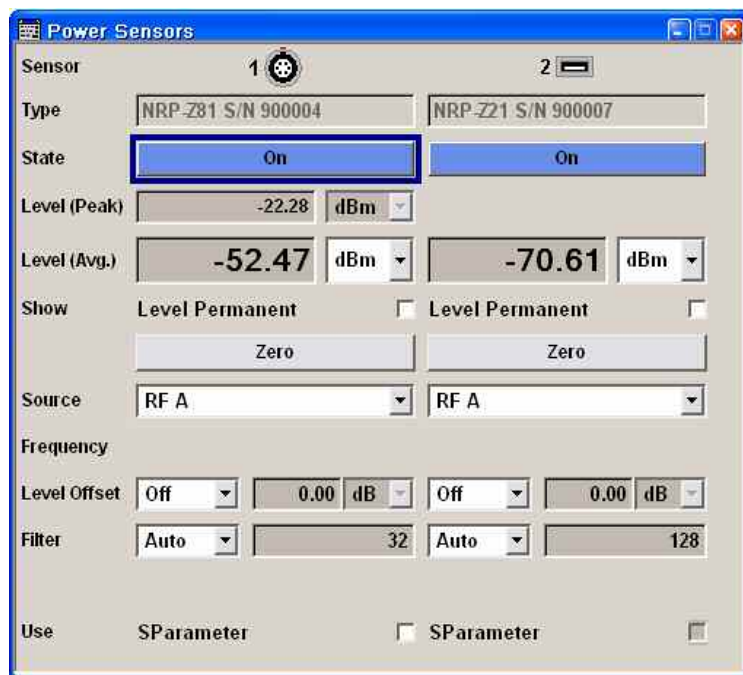
**Sensor - Power Sensors**

Indicates the connector used for the detected sensors. The values listed below belong to the respective sensor.

Remote-control command:

SENS : POW : STAT ?

Response. 0 (no power sensor is connected)

Response. 1 (a power sensor is connected at the Sensor connector)

The sensor is selected by suffix **1**, **2** or **3** in key word SENSE or READ of the command header. Suffix 1 denotes the sensor connected to the SENSOR connector, suffix 2 the sensor connected first to one of the USB interfaces and suffix 3 the sensor connected second to one of the USB interfaces.

**Note:**

*The software version of the connected power sensor can be retrieved by means of the remote control command:*

SENS : POW : SVER ?

**Type - Power Sensors**

Indicates the type of the connected R&S NRP power sensor. The sensor type is automatically detected.

Remote-control command:

SENS : POW : TYPE ?

<b>State - Power Sensors</b>	<p>Activates/deactivates level measurement by the power sensor.</p> <p>Remote-control command: INIT:POW:CONT OFF ON</p> <p>The local state is set with the INIT command. Switching the local state off enhances the measurement performance.</p> <p>In remote control, the sensors are set up using the SENSE commands. The remote measurement is triggered by the READ query which also provides the measurement results. The state is not influenced by these commands, measurements results can be retrieved with local State on or off.</p> <p>SENS:POW:FILT:TYPE USER SENS:POW:FILT:LENG:USER 16 READ:POW?</p>
<b>Level (Peak)- Power Sensors</b>	<p><b>With certain power sensors only, e.g. R&amp;S NRP-Z81.</b></p> <p>Indicates the measured peak level value with the selected unit.</p> <p>Remote-control command: READ:POW?</p> <p>Response: -55.62403263352178, -22.419472478812476 (the second value is the peak level value)</p>
<b>Level (Avg.) - Power Sensors</b>	<p>Indicates the measured level value with the selected unit.</p> <p>Remote-control command:: READ:POW?</p> <p>Response: -45.6246576745440230</p>
<b>Unit - Power Sensors</b>	<p>Selects the unit used for result display.</p> <p>The power sensor provides the measured value in Watt.</p> <p>In which unit the measured value is indicated is selected here and might be Watt, dBm or dBuV.</p> <p>Remote-control command : SENS:UNIT:POW DBM</p>
<b>Show Level Permanent - Power Sensors</b>	<p>Activates the permanent indication of the power measurement result in the upper right corner of the block diagram. For each sensor, the type of sensor, the connector, the measurement source and - if set - the offset is indicated.</p> <p>Remote-control command : SENS:POW:DISP:PERM:STAT ON</p>

**Zero - Power Sensors**

Activates the auto zero function.

Zeroing calibrates the external power sensor by adjusting its reading at zero signal power. For this purpose, the RF power source must be switched off or disconnected from the sensor (see tips below). R&S power sensors automatically detect the presence of any significant input power. This aborts zeroing and generates an error message. Zeroing can take a few seconds, depending on the sensor model; refer to the documentation of your external power sensor for more information.

**Tips for zeroing**

Perform zeroing

- During warm-up after switching on or connecting the instrument
- After a substantial change of the ambient temperature
- After fastening the power sensor module to an RF connector at high temperature
- After several hours of operation
- When very low-power signals are to be measured, e.g. less than 10 dB above the lower measurement limit.
- -Switch off the RF power source for zeroing; do not disconnect it from the power sensor. In this way you will maintain the thermal equilibrium, and zeroing will also compensate for the noise superimposed on the measured signal (e.g. from a broadband amplifier).

Remote-control command:

`SENS:POW:ZERO`

**Source - Power Sensors**

Selects the source for measurement.

**RF A/B**

Measurement source is the RF signal of the generator. The RF frequency is used as the measurement frequency of the sensor and the corresponding correction factor is used.

In this mode the RF frequency of the generator is sent to the sensor automatically if changed.

If two sensors are connected, both sensor can be allocated the same path, e.g. for measurements before and after the DUT.

For single path instruments, only selection RF A is offered.

Remote-control command:

`SENS:POW:SOUR RF`

**User**

Measurements source is any freely selectable source. The frequency is entered manually under frequency (e.g. for measurement of amplifier gain with 2 sensors).

Remote-control command:

`SENS:POW:SOUR USER`

**Frequency - Power Sensors****Source User only**

Enters the frequency for measurement source **User**.

Remote-control command:

```
SENS:POW:FREQ 2.5MHz
```

**Level Offset - Power Sensors**

Activates and defines a level offset which is added to the measured value. This allows e.g. an attenuator in the signal path to be taken into account. The offset is always entered in dB, irrespective of the selected unit for result display.

Remote-control command:

```
SENS:POW:OFFS:STAT ON
```

```
SENS:POW:OFFS -2 dB
```

**Filter Length - Power Sensors**

Selects the filter length used for measurement.

The averaging filter is used to reduce fluctuations in the measured result to the extent desired. Such fluctuations can be caused by inherent noise of the measuring instrument, modulation of the measurement signal or beats from the superposition of adjacent carriers. A more stable display has to be traded off against longer measurements. The measurement result is obtained from a two-stage averaging process.

---

**Note:**

*Longer measurements does not mean that it takes longer to display a new result, but rather that it takes longer for the result to settle when the power changes.*

---

Measurements are continuously repeated in a predefined time window. The measurement result is obtained by averaging the measured values for the last 2N time windows. The number N is the filter length, the factor of 2 arises because the output signals from the microwave detector to suppress low-frequency noise are chopped at the same rate as the time windows, which means that an independent measured value can only be obtained from two consecutive values. As the filter length is the multiplier for the time window it directly influences the measurement time.

The filter length can be selected automatically or can be manually set to a fixed value. As a preliminary, you should always check if the auto mode is giving satisfactory results because you will always have to adjust an optimal, manual filter-length setting if the power is not constant.

Selection **Fixed Noise** is offered for reaching a defined measurement accuracy.



**Auto** The filter length is automatically selected and adapted to the currently measured value. With very high signals the filter length and therefore the measurement time can be short. With very low signal levels the filter length and therefore the measurement time is increased in order to reduce noise. The used filter length is indicated in the field to the right.

Remote-control command :  
 SENS:POW:FILT:TYPE AUTO  
 SENS:POW:FILT:LENG:AUTO?

**User** The filter length is set manually.  
 The filter length is entered in the entry window to the right. As the filter length works as a multiplier for the time window, this results in a constant measurement time. Values 1 and 2<sup>n</sup> are settable.

---

**Note:**

*The time window varies in manual control, it is fixed to 20 ms in remote control.*

---

The **Auto Once** button can be used to search for the optimum filter length for the current measurement conditions. The found filter length is indicated in the field to the right.

Remote-control command :  
 SENS:POW:FILT:TYPE USER  
 SENS:POW:FILT:SONC  
 or  
 SENS:POW:FILT:LENG:USER 16

**Fixed Noise** The averaging factor is selected so that the sensor's intrinsic noise (2 standard deviations) does not exceed the specified noise content.  
 The desired noise content is entered in the entry field to the right.  
 To avoid very long settling times when the power is low, the averaging factor can be limited with the **Timeout** parameter.

Remote-control command:  
 SENS:POW:FILT:TYPE NSR  
 SENS:POW:FILT:NSR 0.001  
 SENS:POW:FILT:NSR:MTIM 4

**Use SParameter - Power Sensors**

Activates the use of the s-parameters correction data of the connected power sensor. For sensor with attenuator this checkbox is automatically checked.

Please see the manual of the connected R&S NRP power sensor for a description on how to use the s-parameters table.

Remote-control command:  
 SENS:POW:CORR:SPD:STAT ON

## User Correction

The "User Correction" function is used to create and activate lists in which level correction values predefined by the user are freely assigned to RF frequencies. Correction is performed by the user-defined table values being added to the output level for the respective RF frequency.

With frequencies which are not contained in the list, the level correction is determined by interpolation of the closest correction values.

The lists are created in the List Editor. Each list is stored in its own file with the predefined file extension \*.uco. The name of the User Correction file can be freely selected. The files are loaded from the **Lists...** file manager. Externally created tables with pairs of frequency and level values can be converted into User Correction files using the import function. The external files must have the file extension \*.txt or \*.csv. These file formats are provided e.g. by the Microsoft Excel program. The separators for table columns and for decimal floating-point numerals can be set. In addition, internally created User Correction data can be exported into ASCII files using the export function.

The amplitude can also be linearized automatically by means of a R&S NRP power sensor connected to one of the generator output signals. With the aid of the **Fill with Sensor** function, a table with correction values for external test assemblies can be automatically determined, e.g. for compensating the frequency response of cables. The User Correction list with the correction values acquired by the sensor is generated in the **Edit User Correction List** menu. The correction values can be acquired any time irrespective of the modulation settings of the generator.

Multi level measurements allow to take into account the changing VSWR for the different attenuator settings.

If user correction is activated, the **UCOR** display (User Correction) is shown in the header together with the **Level** display. The RF output level is the sum of both values.

**Level + UCOR = Output level**

If activated, user correction is effective in all operating modes.

## User Correction Menu

The **User Correction** menu is opened either in the **RF/A Mod** function block or using the **[MENU]** key under **RF/A Mod**.

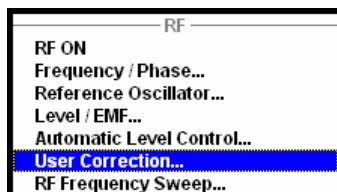

The combined menu Level / EMF / ALC /UCOR provides access to the automatic level control settings in the bottom section. The top sections provide access to the level and attenuator settings, see section "[RF Reference Frequency - Reference Oscillator](#)", page 4.78, and to the automatic level control settings, see section "[Automatic Level Control - ALC](#)", page 4.84.

The menu is used to activate/deactivate user correction, and to create, select and activate the lists.

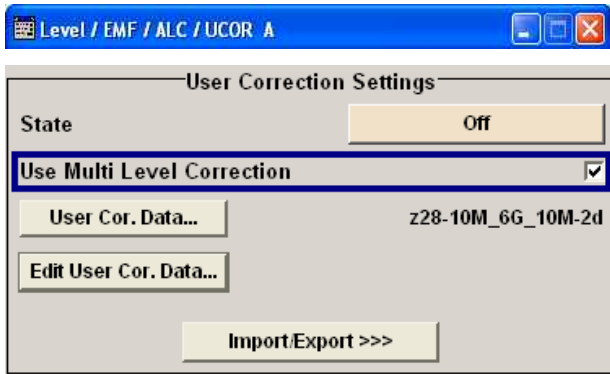

#### State - User Correction

Activates/deactivates user correction.

The **UCOR** status message appears in the frequency and level display.

Remote-control command:

```
SOUR:CORR:STAT ON
```

#### Use Multi Level Correction - User Correction

Only for lists with **Multi Level Correction** measurement data.

Activates the use of the multi level correction data (see "[Filling the Correction List with Power Sensor Measurement Data](#)") if checked. Otherwise the Single Level Correction measurement data is used.

Remote-control command:

```
SOUR:CORR:MLEV:STAT ON
```

#### User Correction Value - User Correction

Indicates the current value for level correction.

Remote-control command:

```
SOUR:CORR:VAL?
```

#### User Cor. Data - User Correction

Calls the **File Select** menu for selecting and creating a list or the **File Manager**.



Remote-control command:

```
MMEM:CDIR 'D:/USER/CSET'
```

```
SOUR:CORR:CSET:CAT?
```

Response:

```
'Ucor1', 'Ucor2'
```

```
SOUR:CORR:CSET:SEL 'Ucor1'
```

```
SOUR:CORR:CSET:DEL 'Ucor2'
```

**Edit User Cor. Data - User Correction**

Calls the editor for editing the selected user correction list. A list consists of any number of frequency/level value pairs. Multi level lists which are filled automatically using the Fill with sensor function consist of nine level columns, one for each attenuator stage (see section "Filling the Correction List with Power Sensor Measurement Data"). The currently selected list is displayed.

**Important:**

Save list only after filling both columns (frequency and level), otherwise the entries are lost.

	Frequency / Hz	Power / dB	Power [1] @ HP/ dB	Power [2] @ 0 dB/ dB	Power [3] @ 5 dB/ dB
1	10 000 000.00	3.00	3.56	3.51	3.52
2	20 000 000.00	3.96	3.52	3.90	3.96
3	30 000 000.00	4.07	3.79	4.07	4.06
4	40 000 000.00	3.70	3.84	3.73	3.70
5	50 000 000.00	3.38	3.56	3.35	3.38
6	60 000 000.00	3.59	3.68	3.58	3.59
7	70 000 000.00	4.04	4.02	4.06	4.04
8	80 000 000.00	4.06	3.90	4.12	4.15
9	90 000 000.00	3.88	3.58	3.82	3.88
10	100 000 000.00	3.64	3.84	3.68	3.63
11	110 000 000.00	3.79	4.26	3.85	3.79
12	120 000 000.00	4.17	4.03	4.07	4.16
13	130 000 000.00	4.36	3.58	4.27	4.35
14	140 000 000.00	4.18	3.94	4.27	4.18
15	150 000 000.00	3.85	4.48	3.96	3.84
16	160 000 000.00	3.91	4.25	3.80	3.90
17	170 000 000.00	4.29	3.71	4.15	4.28

**Frequency /Hz**

Enters the frequency to which the level correction value applies.

**Note:**

The **Fill..** function allows to automatically enter any number of frequencies with freely selectable range and increment. Using the **Fill With Sensor** function of the **Edit** sub menu requires only the entry of the frequency values. The level values are automatically acquired by the connected power sensor.

Remote-control command:

```
SOUR:CORR:CSET:SEL 'Ucor1'
SOUR:CORR:CSET:DATA:FREQ 100MHz,...
```

**Power / Power[1..9] @ HP..35 dB**

Enters the level correction value to which the specified frequency applies. The values can be entered manually or automatically with the **Fill With Sensor** function (available in the **Edit** sub menu).

Remote-control command:

```
SOUR:CORR:CSET:SEL 'Ucor1'
SOUR:CORR:CSET:DATA:POW 1dB,0.8dB,...
```

**Goto**

Selects row for editing.



If Goto row is selected, a window opens for entering the requested row.

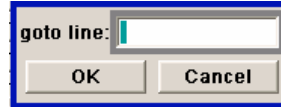

Remote-control command: n.a.  
(it is not possible to change individual positions of the list)

**Edit**

Calls a selection of possible actions described below.

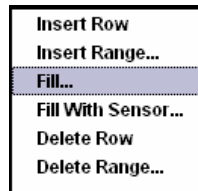
**Insert Row**

Insert a new row before the marked row.

Remote-control command: n.a .

**Insert Range**

Insert new rows before the marked row. The number of rows to be inserted can be defined in an entry window.

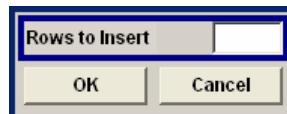

Remote-control command: n.a .

**Fill....**

Opens a sub menu for defining a set of list values to be automatically entered in the ucor list (see section ["Filling the Correction List automatically"](#)).

Remote-control command: n.a.

**Fill With Sensor**

Calls the menu to activate the filling of the user correction list with level values acquired by the selected power sensor (see section ["Filling the Correction List with Power Sensor Measurement Data"](#)).

Remote-control command: n.a.

**Delete Row**

Deletes the marked row.

Remote-control command: n.a .

**Delete Range...** Allows to delete any number of rows starting with the marked row. The number of rows to be deleted can be defined in an entry window.

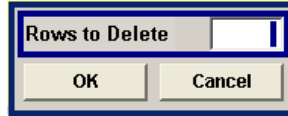

Remote-control command: n.a .

**Save as** Open the file menu to save the list under a new name.

**Important:**

*Save list only after filling both columns (frequency and level), otherwise the entries are lost.*

Each list is saved to the R&S Vector Signal Generator hard disk as a separate file with the file prefix \*.uco. The file name and the directory to which the file is saved are user-selectable.

Remote-control command: -

**Save** The list is saved under its current name.

Remote-control command: -

(the list is automatically saved after the values have been entered)

User correction list can be imported from externally created files or exported into text or CSV-files. The import/export settings are available after clicking the **Import/Export** button.

**Import/Export - User Correction**

Expands the menu with the area for import and export of user correction files.

Externally edited Excel tables with any number of frequency/level value pairs can be imported as text or CSV-files and used for user correction. Multi level lists which are filled automatically using the **Fill with sensor** function consist of nine level columns, one for each attenuator stage (see section "Filling the Correction List with Power Sensor Measurement Data").

On the other hand, internally created user correction list can be exported as text or CSV-files.

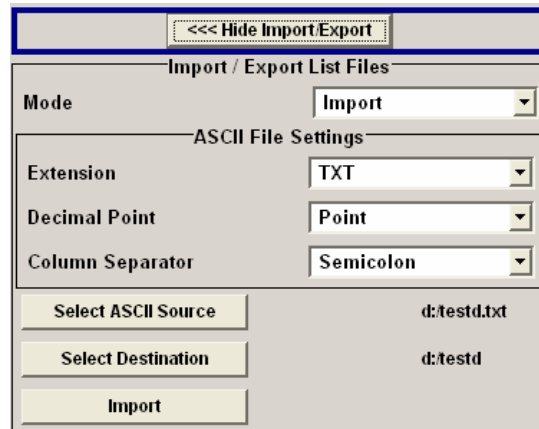

<b>Mode - User Correction</b>	<p>Selects if user correction lists should be imported or exported. The settings offered depend on the selected mode.</p> <p>Remote-control command: SOUR:CORR:DEXC:MODE IMP</p>
<b>Extension - User Correction</b>	<p>Selects the file extension of the ASCII file to be imported or exported. Selection TXT (text file) or CSV (Excel file) is available.</p> <p>Remote-control command: SOUR:CORR:DEXC:AFIL:EXT TXT</p>
<b>Decimal Point - User Correction</b>	<p>Selects the decimal separator used in the ASCII data between '.' (decimal point) and ',' (comma) with floating-point numerals.</p> <p>Remote-control command: SOUR:CORR:DEXC:AFIL:SEP:DEC DOT</p>
<b>Column Separator- User Correction</b>	<p>Selects the separator between the frequency and level column of the ASCII table the user correction list is exported to or imported from.</p> <p>Remote-control command: SOUR:CORR:DEXC:AFIL:SEP:COL TAB</p>
<b>Select ASCII Source / Destination - User Correction</b>	<p>Calls the <b>File Manager</b> for selecting the ASCII file to be imported into a user correction list (source) or the ASCII file the user correction list is exported (destination) in.</p> <p>Remote-control command: SOUR:CORR:DEXC:AFIL:SEL "D:/user/ucor/list1.txt"</p>
<b>Destination / Source - User Correction</b>	<p>Calls the <b>File Manager</b> for selecting the user correction list to be exported (source) into an ASCII file or the destination for the ASCII file to be imported (destination) in.</p> <p>Remote-control command: SOUR:CORR:DEXC:SEL "D:/user/ucor/list1.txt"</p>
<b>Import / Export - User Correction</b>	<p>Starts the export or import of the selected file.</p> <p>When import is selected, the ASCII file is imported as user correction list.</p> <p>When export is selected, the user correction list is exported into the selected ASCII file.</p> <p>Remote-control command: SOUR:CORR:DEXC:EXEC</p>

## Filling the Correction List automatically

The **Fill Table** menu enables you to automatically set the level correction values.

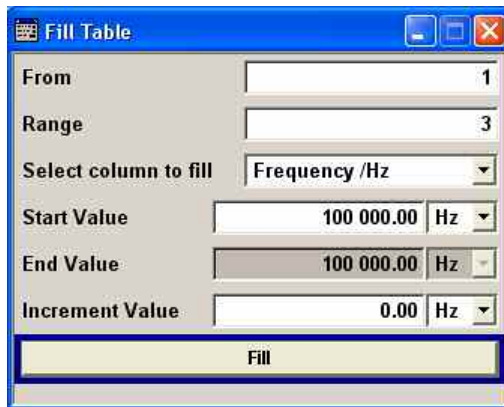

The start line and the number of rows to be filled are defined under **From** and **Range**.

The column to be filled is selected under **Select column to fill**. Depending on the selection here, the default for start, end, and increment value are set. As the settings are interdependent, a change of one parameter may result in the automatic change of one or more of the other parameters.

The filling of the column with the selected value settings is started with button **Fill**.

---

### Note:

*The correction list entries are only computed when the **Fill** button is pressed.*

---

<b>From</b>	Sets the start value of the index range. Remote-control command: n. a.
<b>Range</b>	Sets the range for filling the table. Remote-control command: n. a.
<b>Select column to fill</b>	Selects either the frequency or the level column to be filled with the value defined below. Remote-control command: n. a.
<b>Start value</b>	Sets the start value for the frequency or the level entries. Remote-control command: n. a.
<b>End value</b>	Sets the end value for the frequency or the level entries. Remote-control command: n. a.
<b>With increment</b>	Sets the increment for the frequency or the level entries. Remote-control command: n. a.
<b>Fill</b>	Fills the selected column in the set range with values, starting with the start value and using the set increment. Remote-control command: n. a.



## Filling the Correction List with Power Sensor Measurement Data

The level correction values for the user correction list can be acquired by means of R&S NRP power sensors. The R&S NRP sensors are connected to either the SENSOR connector or to one of the USB interfaces. Configuration of the connection is performed in the **Power Sensor** menu (see "[Power Sensors](#)"). The filling of the ucor list with measurement data is performed in the ucor list editor (see above "[Edit User Cor. Data - User Correction](#)").

In the editor, the frequencies for which the correction values are to be acquired are entered in the frequency column (either manually or by means of the **Fill...** menu).

### **Important:**

*Do not save the list at this point, because the frequency entries are lost as long as there are no entries for the level column also. In the following these entries are automatically acquired by the connected power sensor.*

All level correction values for the given frequency values are measured using the Power sensor and automatically filled in the selected list. The list is automatically stored and recalled again after filling.

The **Fill with Sensor** button of the **Edit User Correction Data** menu opens the associated menu.

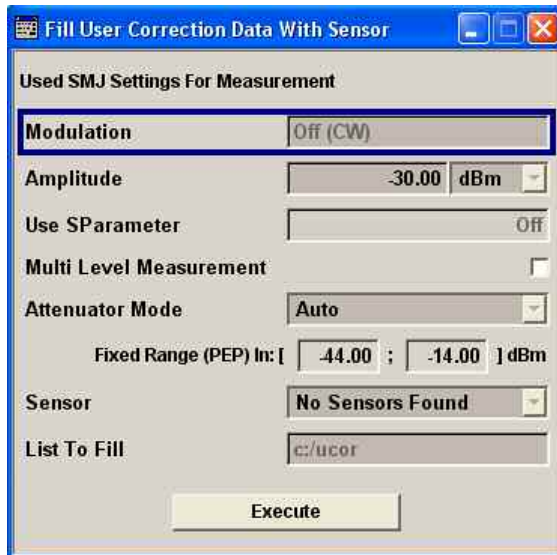

The menu indicates the relevant generator settings.

All settings are read-only, except the **Sensor** and **Multi Level Measurements**.

In case more than one sensor are connected to the instrument, the sensor can be selected in the **Sensor** field of the menu; **Multi Level Correction** can be activated.

The **Execute** button is only enabled if a sensor is detected and the user correction list contains at least one frequency value.

Remote-control command:

```
SOUR:CORR:CSET:DATA:SENS1:POW:SONC
```

(the power sensor used is selected by the suffix in key word SENSE of the command header. Suffix 1 denotes the sensor connected to the SENSOR connector, suffix 2 the sensor connected first to one of the USB interfaces and suffix 3 the sensor connected second to one of the USB interfaces.)

When **Multi Level Correction** is activated, separate measurements are made for the different attenuator settings up to 35 dB. Thus, the changes in VSWR for the different settings are taken into account, the level accuracy increases. For ranges from 40 dB on the changes in VSWR are negligible.

The reference level is set internally and cannot be controlled by the user. The measurement results are entered into additional columns of the User Correction list.

	Frequency / Hz	Power / dB	Power [1] @ HP / dB	Power [2] @ 0 dB / dB	Power [3] @ 5 dB / dB	Power [4] @ dB
1	10 000 000.00	3.53	3.56	3.51	3.52	3.54
2	20 000 000.00	3.96	3.52	3.90	3.96	3.95
3	30 000 000.00	4.07	3.79	4.07	4.06	4.05
4	40 000 000.00	3.70	3.84	3.73	3.70	3.72
5	50 000 000.00	3.38	3.56	3.35	3.38	3.42
6	60 000 000.00	3.59	3.68	3.58	3.59	3.62
7	70 000 000.00	4.04	4.02	4.06	4.04	4.06
8	80 000 000.00	4.15	3.90	4.12	4.15	4.19

The Multi Level Correction measurements are made **in addition** to a Single Level Correction measurement. When the user correction list is activated, it is possible to select which of the measurements is to be used for level correction.

Remote-control command:

```
SOUR:CORR:CSET:DATA:POW:MLEV:STAT ON
SOUR:CORR:CSET:DATA:POW:MLEV3?
```

(the measurement values for the different attenuator settings are retrieved separately. The numeric suffix at MLEV correlates to the index of the column, e.g. suffix 3 denotes the column with the values for attenuator setting 5 dB.)

## Overvoltage Protection

The R&S Vector Signal Generator (all frequency options) is equipped against overloading by an external signal applied to the RF output (starting from serial number 101001).

The overload protection is tripped when the power of the external signal becomes too high. A relay opens and interrupts the connection between the RF output and attenuator. This condition is indicated in the display header by the 'OVERLOAD' status message.

- Reset the overload protection by pressing the **[RF ON/OFF]** key. The RF input is activated when the overload protection is reset.

Remote-control commands:

```
OUTP:PROT:TRIP?
OUTP:PROT:CLE
OUTP:STAT ON
```

## List Mode - List

Similar to a sweep, a series of previously defined frequency and level points is processed in List mode. In contrast to a sweep, however, a list with freely selectable value pairs (frequency and level) can be created. The value range for frequency and level covers the entire configurable value range of the instrument.

---

### Note:

*List mode and sweeps can not be activated simultaneously, they deactivate each other.*

---

The lists can be created in the List Editor. Each list is stored in its own file with the predefined file extension \*. **lsw**. The name of the List file can be freely selected. The files are loaded from the **Lists...** file manager. Externally created tables with pairs of frequency and level values can be converted into List files using the import function. The external files must have the file extension \*.txt or \*.csv. These file formats are provided e.g. by the Microsoft Excel program. The separators for table columns and for decimal floating-point numerals can be set. In addition, internally created List data can be exported into ASCII files using the export function.

The necessary hardware settings are calculated the first time a list is processed. With long dwell times, this calculation can be performed while the list is being processed; the entered dwell times are observed. With very short dwell times, calculation of the hardware settings increases the dwell time for the initial processing cycle; the entered value is only observed from the second processing cycle onwards. In this case a message appears to inform the user that there is a deviation between the current and set dwell times. No further calculations are required after the first run through a list. The current dwell times will definitely no longer deviate from the set dwell times.

The list is processed from the beginning to the end of the list (modes **Auto**, (**External**) **Single**, (**External**) **Step**).

The **List Mode** menu is opened either in the **RF/Ana Mod** function block or using the **[MENU]** key under **RF/Ana Mod**.

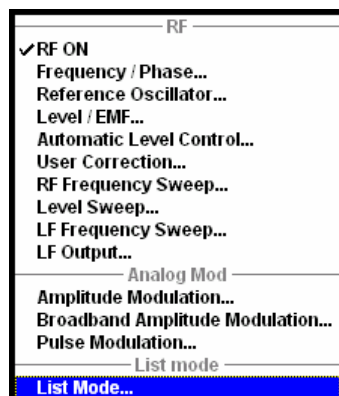

The menu is used to activate/deactivate operating mode List, to create, select and activate the lists, and to select the trigger mode and the dwell time.

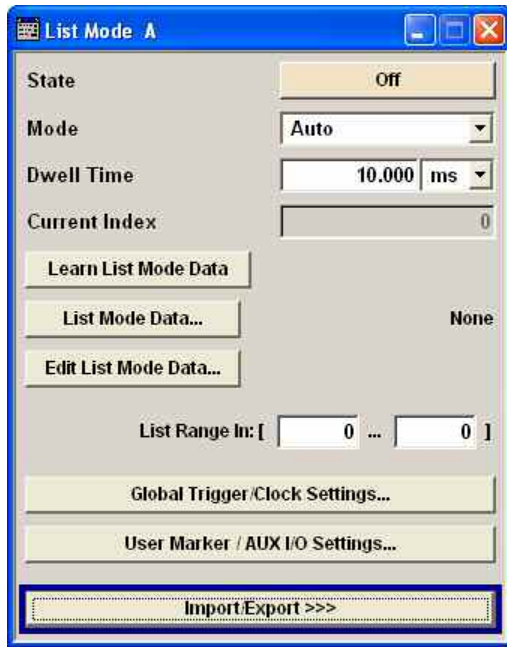

### State - List Mode

Activates/deactivates the List mode. The currently selected list is processed.

In case of a new or modified list, the necessary hardware settings are automatically determined on activation of the list mode. The data determined in this way is stored along with the list and is available whenever the list is used again.

This means that when activating the list mode, the system checks whether any hardware settings are present. If so, the list is started immediately, but if not they are automatically determined (the list is learnt).

A **Learn List Mode Data** button is available for deliberately activating list learning.

---

#### Note:

*Activating the list mode automatically deactivates all sweeps.*

---

Remote-control command:

```
SOUR:FREQ:MODE LIST
```

### Mode - List Mode

Selects the cycle mode of the List mode.

#### Auto

Cycle from the beginning to the end of the list with automatic restart at the beginning. If a different mode was activated prior to the Auto mode, the cycle continues from the beginning of the list. The duration of a list step is determined by the set dwell time.

Remote-control command:

```
SOUR:FREQ:MODE LIST
SOUR:LIST:MODE AUTO
SOUR:LIST:TRIG:SOUR AUTO
```

**Single**

Single cycle from the beginning to the end of the list. If **Single** is selected, the cycle is not started immediately. The **Execute Single** button appears under the **Mode** line. The cycle is started with this button. The duration of a list step is determined by the set dwell time.

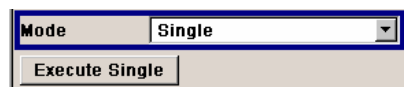

Remote-control command:

```
SOUR:FREQ:MODE LIST
SOUR:LIST:MODE AUTO
SOUR:LIST:TRIG:SOUR SING
SOUR:LIST:TRIG:EXEC
```

**Step**

Manual, step-by-step processing of the list. Activating **Step** stops the current list and the cursor moves to the value displayed for **Current Index**. It is now possible to scroll up and down in the list in discrete steps by varying the index. The duration of a list step is determined by the time between two index entries.



Remote-control command:

```
SOUR:FREQ:MODE LIST
SOUR:LIST:MODE STEP
SOUR:LIST:TRIG:SOUR SING
```

**Extern Single**

Single cycle from the beginning to the end of the list as with **Single**, but started by an external trigger.

The external trigger signal is input at the rear of the instrument.

Remote-control command:

```
SOUR:FREQ:MODE LIST
SOUR:LIST:MODE AUTO
SOUR:LIST:TRIG:SOUR EXT
```

**Extern Step**

Step-by-step cycle using the external trigger signal. Each trigger event starts a single step. The duration of a list step is determined by the time between two trigger events.

The external trigger signal is input at the rear of the instrument.

Remote-control command:

```
SOUR:FREQ:MODE LIST
SOUR:LIST:MODE STEP
SOUR:LIST:TRIG:SOUR EXT
```

**Execute Single - List Mode** Triggers the list manually. This button is available only if **Mode Single** is selected.

Remote-control commands

```
SOUR:FREQ:MODE LIST
SOUR:LIST:MODE AUTO
SOUR:LIST:TRIG:SOUR SING
SOUR:LIST:TRIG:EXEC
```

**Reset - List Mode** Resets the list to the starting point.

Remote-control command:

```
SOUR:LIST:RES
```

**Dwell Time - List Mode** Enters the dwell time. The dwell time determines the duration of a list step in list operating modes **Auto**, **Single** and **Extern Single**. In these modes a complete list is processed either once or continuously.

In list operating modes **Step** and **Extern Step**, the set dwell time does not affect signal generation. In this case, the duration of a list step is determined by the time between two (internal or external) trigger events.

Remote-control command:

```
SOUR:LIST:DWEL 10 ms
```

**Current Index - List Mode** Sets the list index in **Step** mode.

Remote-control command: n.a.

**Blank RF Output (Default ON) - List Mode** Activates/deactivates RF output blanking. If activated, blanking occurs on all frequency changes. If deactivated, blanking is always disabled.

Remote-control command:

```
OUTP:BLAN:LIST:STAT ON
```

**Learn List Mode Data... - List Mode** Starts the determination of the hardware setting for the selected list. The data determined in this way is stored along with the list.

It may be necessary to deliberately activate list learning in the event of greatly altered environmental conditions that require new hardware settings.

If this is not done, a previously learned hardware setting will continue to be used when list mode is switched on (**State = On**). If no setting is available, e.g. when the list is used for the first time, learning is automatically activated.

Remote-control command:

```
SOUR:LIST:LEAR
```

**List Mode Data... - List Mode**

Calls the **File Select** menu for selecting and creating a list or the **File Manager**.



Remote-control command:

```
MMEM:CDIR 'D:/USER/LIST'
SOUR:LIST:CAT?
Response: 'MYLIST', 'LIST1', 'LIST2'
SOUR:LIST:SEL 'LIST2'
SOUR:LIST:DEL 'LIST1'
SOUR:LIST:DEL:ALL
```

**Edit List Mode Data... - List Mode**

Calls the editor for editing the selected list. A list consists of any number of frequency/level value pairs. The currently selected list is displayed.

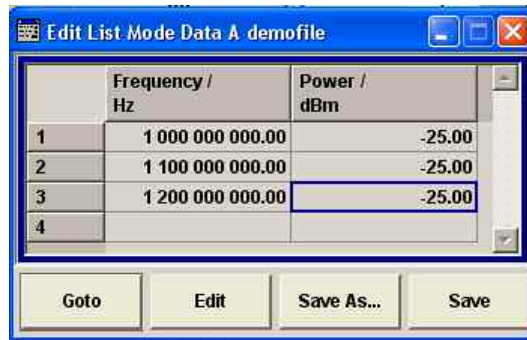

**Frequency /Hz**

Enter the frequency of the frequency/power value pair.

Remote-control command:

```
SOUR:LIST:FREQ 1.4GHz,1.3GHz,1GHz...
```

**Power /dBm**

Enter the level of the frequency/power value pair.

Remote-control command:

```
SOUR:LIST:POW 0dBm, 2dBm,2dBm,3dBm,...
```

**Goto**

Selects row for editing.



If Goto row is selected, a window opens for entering the requested row.

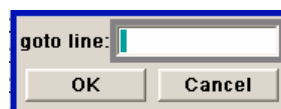

Remote-control command: n.a.

(it is not possible to change individual positions of the list)

**Edit**

Calls a selection of possible actions described below.



Remote-control command: n.a.

**Insert Row**

Inserts a new row before the marked row.

Remote-control command: n.a.

**Insert Range**

Inserts new rows before the marked row. The number of rows to be inserted can be defined in an entry window.

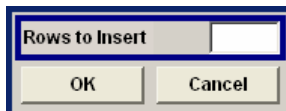

Remote-control command: n.a.

**Fill....**

Opens a sub menu for defining a set of list values to be automatically entered in the List Mode table (see section ["Filling the List Mode Data automatically"](#)).

Remote-control command: n.a.

**Delete Row**

Deletes the marked row.

Remote-control command: n.a.

**Delete Range...**

Allows to delete any number of rows starting with the marked row. The number of rows to be deleted can be defined in an entry window.

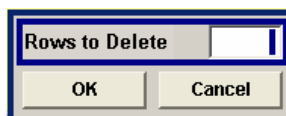

Remote-control command: n.a.

**Save as**

Open the file menu to save the list under a new name.

Each list is saved to the R&S Signal Generator hard disk as a separate file with the file prefix **\*.lsw**. The file name and the directory to which the file is saved are user-selectable.

Remote-control command: n.a.



**Save** The list is saved under its current name.  
 Remote-control command:  
 (the list is saved automatically after the values have been entered)

**List Range In - List Mode** Defines an index range in the current list by setting the start and stop index. Only the values in the selected index range are processed in List mode, all other list entries are ignored.  
 Remote-control command:  
 SOUR:LIST:IND:STAR 15  
 SOUR:LIST:IND:STOP 155

**Global Trigger/Clock Settings - List Mode** Open the **Global Trigger/Clock Settings** menu. This menu is used among other things for setting the polarity of the active slope of an applied instrument trigger

See also section "[Global Trigger/Clock/External Input Settings - Setup-Environment](#)", on page 4.13.

**User Marker AUX I/O Settings - List Mode** Calls the menu for configuring the AUX I/O and user interfaces (see the following section "[User Marker / AUX I/O - Setup-Environment-Global...Settings](#)").

The pin assignment of the AUX I/O interface is shown in the **User Marker - AUX I/O Configuration** menu; the assignment of the USER pins 2...4 and USER 1 BNC connector can be changed.

User correction list can be imported from externally created files or exported into text or CSV-files. The import/export settings are available after clicking the **Import/Export** button.

**Import/Export - List Mode** Expands the menu with the area for import and export of list mode files.

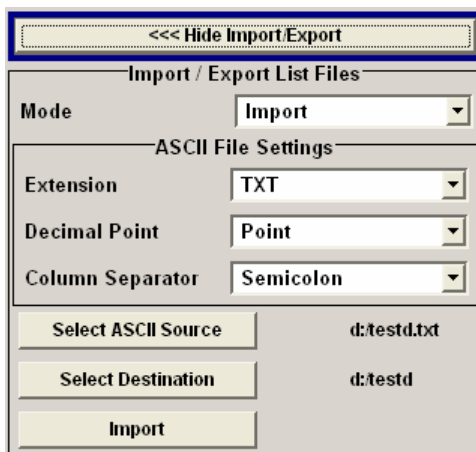

Externally edited Excel tables with frequency/level pairs can be imported as text or CSV-files and used for list mode.

On the other hand, internally created list mode list can be exported as text or CSV-files.

<b>Mode - List Mode</b>	<p>Selects if list mode lists should be imported or exported. The settings offered below depend on the selected mode.</p> <p>Remote-control command: SOUR:LIST:DEXC:MODE IMP</p>
<b>Extension - List Mode</b>	<p>Selects the file extension of the ASCII file to be imported or exported. Selection TXT (text file) or CSV (Excel file) is available.</p> <p>Remote-control command: SOUR:LIST:DEXC:AFIL:EXT TXT</p>
<b>Decimal Point - List Mode</b>	<p>Selects the decimal separator used in the ASCII data between '.' (decimal point) and ',' (comma) with floating-point numerals.</p> <p>Remote-control command: SOUR:LIST:DEXC:AFIL:SEP:DEC DOT</p>
<b>Column Separator- List Mode</b>	<p>Selects the separator between the frequency and level column of the ASCII table.</p> <p>Remote-control command: SOUR:LIST:DEXC:AFIL:SEP:COL TAB</p>
<b>Select ASCII Source / Destination - List Mode</b>	<p>Calls the <b>File Manager</b> for selecting the ASCII file to be imported into a list mode list (source) or the ASCII file the list mode list is exported (destination) in.</p> <p>Remote-control command: SOUR:LIST:DEXC:AFIL:SEL "var/user/list/list1.txt"</p>
<b>Destination / Source - List Mode</b>	<p>Calls the <b>File Manager</b> for selecting the list mode list to be exported (source) into an ASCII file or the destination for the ASCII file to be imported (destination) in.</p> <p>Remote-control command: SOUR:LIST:DEXC:SEL "var/user/ucor/list1.txt"</p>
<b>Import / Export - List Mode</b>	<p>Starts the export or import of the selected file.</p> <p>When import is selected, the ASCII file is imported as list mode list.</p> <p>When export is selected, the list mode list is exported into the selected ASCII file.</p> <p>Remote-control command: SOUR:LIST:DEXC:EXEC</p>

## Filling the List Mode Data automatically

The **Fill List Mode Data** menu enables you to automatically set the values in the List Mode table.

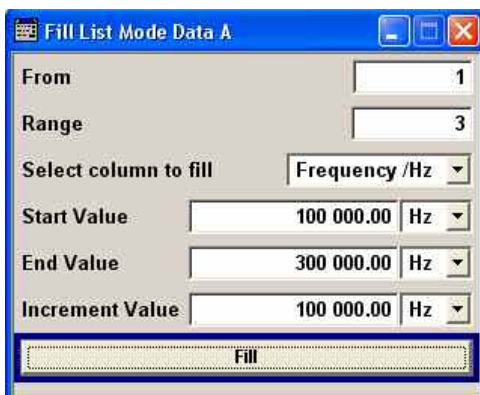

The start line and the number of rows to be filled are defined under **From** and **Range**.

The column to be filled is selected under **Select column to fill**. Depending on the selection here, the default for start, end, and increment value are set. As the settings are interdependent, a change of one parameter may result in the automatic change of one or more of the other parameters.

The filling of the column with the selected value settings is started with button **Fill**.

---

### Note:

*The list entries are only computed when the **Fill** button is pressed.*

---

<b>From</b>	Sets the start value of the index range. Remote-control command: n. a.
<b>Range</b>	Sets the range for filling the table. Remote-control command: n. a.
<b>Select column to fill</b>	Selects either the frequency or the level column to be filled with the value defined below. Remote-control command: n. a.
<b>Start value</b>	Sets the start value for the frequency or the level entries. Remote-control command: n. a.
<b>End value</b>	Sets the end value for the frequency or the level entries. Remote-control command: n. a.
<b>With increment</b>	Sets the increment for the frequency or the level entries. Remote-control command: n. a.
<b>Fill</b>	Fills the selected column in the set range with values, starting with the start value and using the set increment. Remote-control command: n. a.

## Sweep Mode

The R&S Vector Signal Generator offers three different sweep types (frequency sweep, level sweep and LF sweep) to be activated alternatively. Each type has 5 modes which differ with respect to the sweep cycle mode (continuous, individual and step-by-step) and triggering mode (automatic, internal and external).

A phase continuous frequency sweep can be generated after activating the phase continuous mode, see section "[Setting a Phase Continuous Frequency Sweep](#)", on page 4.76.

A sweep is set in five basic steps which are shown below taking a frequency sweep as an example:

1. Set the sweep range (**Start Freq** and **Stop Freq** or **Center Freq** and **Span**).
2. Select linear or logarithmic sweep spacing (**Spacing**).
3. Set the step width (**Step Lin/Log**) and dwell time (**Dwell Time**).
4. Activate the sweep (Mode to Auto, Single, Step or Extern Single, Extern Step).
5. Trigger the sweep, except for Auto mode (Execute Single Sweep, Current Frequency or External Trigger Signal).

---

### Note:

*Sweeps and List mode can not be activated simultaneously, they deactivate each other.*

---

## Frequency Sweep Menu

The **Frequency Sweep** menu is opened either in the **RF/A Mod** function block or in the menu tree of the **[MENU]** key under **RF Signal**.



In the top section of the menu, the RF sweep mode is activated and the sweep mode is selected.

The buttons are used to reset the RF sweep (all sweep modes) or to execute the RF sweep (**Single** mode).

The sweep range, sweep spacing and dwell time are set in the bottom section.

The sweep range of the RF sweep can be entered in two ways, either by entering the **Start** and **Stop** value or by entering the **Center** and **Span**. The two sets of parameters influence each other in the following way:

Start = (Center - Span/2)

Stop = (Center + Span/2)

Center = (Start + Stop)/2

Span = (Stop - Start)

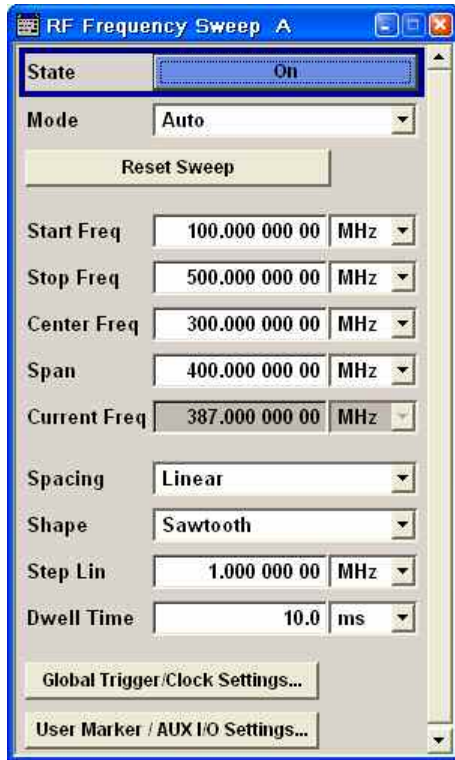

In the top section of the menu, the RF sweep mode is activated and the sweep mode is selected. The buttons are used to reset the RF sweep (all sweep modes) or to execute the RF sweep (**Single** mode).

**State - Frequency Sweep** Activates/deactivates RF sweep mode.

---

**Note:**

*Activating the RF sweep automatically deactivates the list mode, level sweep and LF sweep in the same path.*

---

Remote-control commands:

SOUR:FREQ:MODE SWE

**Mode - Frequency Sweep** Selects the Sweep instrument operating mode and the Sweep mode.

**Auto**

Sets an automatic repeated sweep cycle. If a different sweep mode was activated prior to the **Auto** mode, the cycle continues from the current sweep setting.

Remote-control commands:

SOUR:SWE:FREQ:MODE AUTO

TRIG:FSW:SOUR AUTO

SOUR:FREQ:MODE SWE

<b>Single</b>	<p>Sets a single sweep cycle. The sweep is triggered by the <b>Execute Single Sweep</b> button.</p> <p>If a different sweep mode was activated prior to the <b>Single</b> mode, the current sweep is stopped. The <b>Single</b> sweep always starts at the start frequency when triggered.</p> <p>Remote-control commands: SOUR:SWE:FREQ:MODE AUTO TRIG:FSW:SOUR AUTO SOUR:FREQ:MODE SWE SOUR:SWE:FREQ:EXEC</p>
<b>Step</b>	<p>Sets a step-by-step sweep cycle.</p> <p>If this mode is activated, the cursor moves to the value displayed for <b>Current Freq</b>. Any variation to the <b>Current Freq</b> value triggers a sweep step.</p> <p>If a different sweep mode was activated prior to the <b>Step</b> mode, the current sweep is stopped. The <b>Step</b> sweep starts at the current RF frequency when triggered.</p> <p>The <b>Reset</b> button resets the sweep to the start frequency.</p> <p>Remote-control commands: SOUR:SWE:FREQ:MODE MAN SOUR:FREQ:MODE SWE SOUR:SWE:FREQ:SPAC LIN SOUR:SWE:FREQ:STEP:LIN 0.5E4 SOUR:FREQ:MAN 1GHz</p> <p>(the value entered with command SOUR:SWE:FREQ:STEP:LIN LOG sets the step width. The value entered with command SOUR:FREQ:MAN has no effect, the command only triggers the next sweep step. However, the value has to be in the currently set sweep range (start to stop). In remote control only a step-by-step sweep from start to stop frequency is possible)</p>

<b>Extern Single</b>	<p>Sets a single sweep cycle. The sweep is triggered by an external trigger signal.</p> <p>If a different sweep mode was activated prior to the <b>Extern Single</b> mode, the current sweep is stopped. The <b>Extern Single</b> sweep always starts at the start frequency when triggered.</p> <p>The external trigger signal is input at the rear of the instrument.</p> <p>The <b>Reset</b> button resets the sweep to the start frequency.</p> <p>Remote-control command:  SOUR:SWE:FREQ:MODE AUTO  TRIG:FSW:SOUR EXT  SOUR:FREQ:MODE SWE  (External trigger)</p>
<b>Extern Step</b>	<p>Sets a step-by-step sweep cycle. Each sweep step is triggered by an external trigger signal (trigger source as described under <b>Extern Single</b>).</p> <p>If a different sweep mode was activated prior to the <b>Extern Step</b> mode, the current sweep is stopped. The <b>Extern Step</b> sweep always starts at the start frequency when triggered.</p> <p>The <b>Reset</b> button resets the sweep to the start frequency.</p> <p>Remote-control command:  SOUR:SWE:FREQ:MODE STEP  SOUR:SWE:FREQ:SPAC LIN  SOUR:SWE:FREQ:STEP:LIN 1 MHz  TRIG:FSW:SOUR EXT  SOUR:FREQ:MODE SWE  (External trigger)</p>

The sweep range, sweep spacing and dwell time are set in the bottom section.

<b>Execute Single Sweep - Frequency Sweep</b>	<p>Triggers the sweep manually. A manual sweep can only be triggered if <b>Mode Single</b> is selected.</p> <p>Remote-control commands  SOUR:SWE:FREQ:MODE AUTO  TRIG:FSW:SOUR SING  SOUR:FREQ:MODE SWE  SOUR:SWE:FREQ:EXEC</p>
<b>Reset Sweep - Frequency Sweep</b>	<p>Resets the sweep. The start frequency is set and the next sweep starts from there.</p> <p>Remote-control command:  SWE:RES:ALL</p>
<b>Start Freq - Frequency Sweep</b>	<p>Sets the start frequency.</p> <p>Remote-control command:  SOUR:FREQ:STAR 100MHz</p>

<b>Stop Freq - Frequency Sweep</b>	<p>Sets the stop frequency.</p> <p>Remote-control command: SOUR:FREQ:STOP 500MHz</p>
<b>Center Freq - Frequency Sweep</b>	<p>Sets the center frequency.</p> <p>Remote-control command: SOUR:FREQ:CENT 300MHz</p>
<b>Span - Frequency Sweep</b>	<p>Sets the span.</p> <p>Remote-control command: SOUR:FREQ:SPAN 400MHz</p>
<b>Current Freq - Frequency Sweep</b>	<p>Displays the current frequency.</p> <p>If <b>Step</b> is set, the frequency for the next frequency step of the sweep is entered here.</p> <p>Remote-control command SOUR:FREQ:MAN 300MHz</p>
<b>Spacing - Frequency Sweep</b>	<p>Selects linear or logarithmic sweep spacing.</p> <p>Remote-control command: SOUR:SWE:FREQ:SPAC LIN   LOG</p>
<b>Shape - RF Frequency Sweep</b>	<p>Selects the cycle mode for a sweep sequence (shape) .</p>

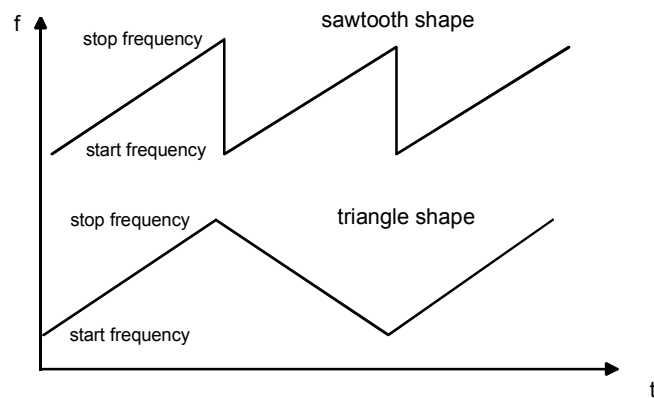

**Sawtooth** One sweep runs from start to stop frequency. Each subsequent sweep starts at the start frequency, i.e. the shape of the sweep sequence resembles a sawtooth.

Remote-control command:  
SOUR:SWE:FREQ:SHAP SAWT

**Triangle** One sweep runs from start to stop frequency and back, i.e. the shape of the sweep resembles a triangle. Each subsequent sweep starts at the start frequency.

Remote-control command:  
SOUR:SWE:FREQ:SHAP TRI



**Step Lin/Log - Frequency Sweep**

Sets the step width for the individual sweep steps. This entry is effective for all sweep modes.

**Step Lin** or **Step Log** is displayed depending on whether **Spacing Lin** or **Log** is selected.

**Step Lin**

With the linear sweep, the step width is a fixed frequency value which is added to the current frequency. The linear step width is entered in Hz.

Remote-control command:

```
SOUR:SWE:FREQ:STEP:LIN 1 MHz
```

**Step Log**

With the logarithmic sweep, the step width is a constant fraction of the current frequency. This fraction is added to the current frequency. The logarithmic step width is entered in %.

Remote-control command:

```
SOUR:SWE:FREQ:STEP:LOG 1 PCT
```

**Dwell Time - Frequency Sweep**

Sets the dwell time. The dwell time determines the duration of the individual sweep steps.

Remote-control command:

```
SOUR:SWE:FREQ:DWEL 10ms
```

**Global Trigger/Clock Settings - Frequency Sweep**

Calls the **Global Trigger/Clock Settings** menu. This menu is used among other things for setting the polarity of the active slope of an applied instrument trigger.

See also section "[Global Trigger/Clock/External Input Settings - Setup-Environment](#)", page 4.13.

**User Marker / AUX I/O - Global Settings**

Calls the menu for configuring the AUX I/O and user interfaces (see the following section "[User Marker / AUX I/O - Setup-Environment-Global...Settings](#)").

The pin assignment of the AUX I/O interface is shown in the **User Marker / AUX I/O Configuration** menu; the assignment of the USER pins 2...4 and USER 1 BNC connector can be changed.

## Level Sweep Menu

The **Level Sweep** menu is opened either in the **RF/A Mod** function block or using the **[MENU]** key under **RF/A Mod**.

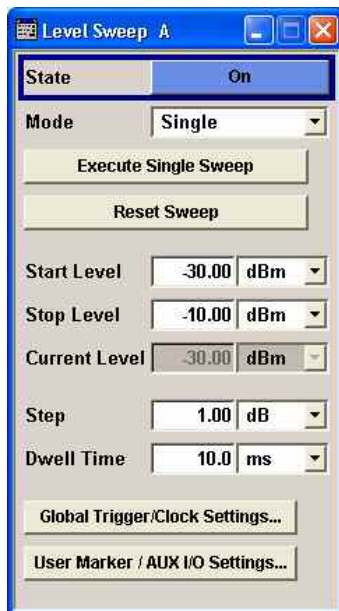
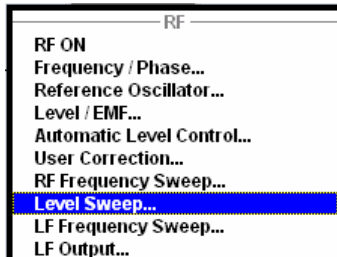

In the top section, the Level Sweep mode is activated and the sweep mode is selected. The buttons are used to reset the level sweep (all sweep modes) or to execute the level sweep (**Single** mode).

The sweep range, sweep spacing and dwell time are set in the bottom section.

In the top section, the Level Sweep mode is activated and the sweep mode is selected. The buttons are used to reset the level sweep (all sweep modes) or to execute the level sweep (**Single** mode).

### State - Level Sweep

Activates Level Sweep mode.

---

#### Note:

*Activating the level sweep automatically deactivates the list mode, RF sweep and LF sweep in the same path.*

---

#### Remote-control commands:

```
SOUR:POW:MODE SWE
SOUR:POW:MODE CW
```

<b>Mode - Level Sweep</b>	<p>Selects the Level Sweep instrument operating mode and the Sweep mode.</p>
<b>Auto</b>	<p>Sets an automatic repeated sweep cycle. If a different sweep mode was activated prior to the <b>Auto</b> mode, the cycle continues from the current sweep setting.</p> <p>Remote-control commands:  SOUR:SWE:POW:MODE AUTO  TRIG:PSW:SOUR AUTO  SOUR:POW:MODE SWE</p>
<b>Single</b>	<p>Sets a single sweep cycle. The sweep is triggered by the <b>Execute Single Sweep</b> button.</p> <p>If a different sweep mode was activated prior to the <b>Single</b> mode, the current sweep is stopped. The <b>Single</b> sweep always starts at the start level.</p> <p>Remote-control commands:  SOUR:SWE:POW:MODE AUTO  TRIG:PSW:SOUR SING  SOUR:POW:MODE SWE  SOUR:SWE:POW:EXEC</p>
<b>Step</b>	<p>Sets a step-by-step sweep cycle.</p> <p>If this mode is activated, the cursor moves to the value displayed for <b>Current Level</b>. Each sweep step is triggered by a variation of the value in the <b>Current Level</b> entry window. The step width is set below at entry field <b>Step</b>.</p> <p>If this mode is activated, the cursor moves to the value displayed for <b>Current Level</b>. If a different sweep mode was activated prior to the <b>Step</b> mode, the current sweep is stopped. The <b>Step</b> sweep starts at the current level value.</p> <p>The <b>Reset</b> button resets the sweep to the start level.</p> <p>Remote-control commands:  SOUR:SWE:POW:MODE MAN  SOUR:SWE:POW:STEP 0.5  SOUR:POW:MODE SWE  SOUR:POW:MAN -16  (the value entered with command  SOUR:SWE:POW:STEP sets the step width. The value entered with command SOUR:POW:MAN has no effect, the command only triggers the next sweep step. However, the value has to be in the sweep range (start to stop value) In remote control only a step-by-step sweep from start to stop level is possible)</p>

<b>Extern Single</b>	<p>Sets a single sweep cycle. The sweep is triggered by an external trigger signal.</p> <p>If a different sweep mode was activated prior to the <b>Extern Single</b> mode, the current sweep is stopped. The <b>Extern Single</b> sweep always starts at the start level.</p> <p>The external trigger signal is input at the rear of the instrument</p> <p>The <b>Reset</b> button stops the sweep and resets it to the start level.</p> <p>Remote-control command:  SOUR:SWE:POW:MODE AUTO  TRIG:PSW:SOUR EXT  SOUR:POW:MODE SWE  (External trigger)</p>
<b>Extern Step</b>	<p>Sets a step-by-step sweep cycle. Each sweep step is triggered by an external trigger signal (trigger source as described under <b>Extern Single</b>). The step width corresponds to the step width of the rotary knob.</p> <p>If a different sweep mode was activated prior to the <b>Extern Step</b> mode, the current sweep is stopped. The <b>Extern Step</b> sweep always starts at the start level.</p> <p>The <b>Reset</b> button stops the sweep and resets it to the start level.</p> <p>Remote-control command:  SOUR:SWE:POW:MODE STEP  SOUR:SWE:POW:STEP 0.5  TRIG:PSW:SOUR EXT  SOUR:POW:MODE SWE  (External trigger)</p>
<b>Reset Sweep - Level Sweep</b>	<p>Resets the sweep. The start level is set and the next sweep starts from there.</p> <p>Remote-control command:  SWE:RES:ALL</p>
<b>Execute Single Sweep - Level Sweep</b>	<p>Triggers the sweep manually. A manual sweep can only be triggered if <b>Mode Single</b> is selected.</p> <p>Remote-control commands  SOUR:SWE:POW:MODE AUTO  TRIG:PSW:SOUR SING  SOUR:POW:MODE SWE  SOUR:SWE:POW:EXEC</p>

The sweep range, sweep spacing and dwell time are set in the bottom section.

<b>Start Level - Level Sweep</b>	<p>Sets the start level.</p> <p>Remote-control command: SOUR:POW:STAR -100</p>
<b>Stop Level - Level Sweep</b>	<p>Sets the stop level.</p> <p>Remote-control command: SOUR:POW:STOP -10</p>
<b>Current Level - Level Sweep</b>	<p>Displays the current level.</p> <p>If <b>Step</b> is set, the level for the next level step of the sweep is entered here.</p> <p>Remote-control command SOUR:POW:MAN -30</p>
<b>Shape - RF Level Sweep</b>	<p>Selects the cycle mode for a sweep sequence (shape) .</p>
	<p><b>Sawtooth</b>      One sweep runs from the start level to the stop level. The subsequent sweep starts at the start level again, i.e. the shape of sweep sequence resembles a sawtooth.</p> <p>Remote-control command : SOUR:SWE:POW:SHAP SAWT</p>
	<p><b>Triangle</b>      One sweep runs from start to stop level and back, i.e. the shape of the sweep resembles a triangle. Each subsequent sweep starts at the start level again.</p> <p>Remote-control command : SOUR:SWE:POW:SHAP TRI</p>
<b>Step - Level Sweep</b>	<p>Sets the step width for the individual sweep steps. This entry is effective for all sweep modes.</p> <p>With the level sweep, the logarithmic step width is a constant fraction of the current level. This fraction is added to the current level. The logarithmic step width is entered in dB.</p> <p>Remote-control command: SOUR:SWE:POW:STEP 3</p>
<b>Dwell Time - Level Sweep</b>	<p>The enter the dwell time. The dwell time determines the duration of the individual sweep steps.</p> <p>Remote-control command: SOUR:SWE:POW:DWEL 10ms</p>

**Global Trigger/Clock Settings - Level Sweep**

Open the **Global Trigger/Clock Settings** menu. This menu is used among other things for setting the polarity of the active slope of an applied instrument trigger

See also section "[Global Trigger/Clock/External Input Settings - Setup-Environment](#)", on page 4.13.

**User Marker / AUX I/O - Global Settings**

Calls the menu for configuring the AUX I/O and user interfaces (see the following section "[User Marker / AUX I/O - Setup-Environment-Global...Settings](#)").

The pin assignment of the AUX I/O interface is shown in the **User Marker / AUX I/O Configuration** menu; the assignment of the USER pins 2...4 and USER 1 BNC connector can be changed.

## LF Frequency Sweep Menu

The **LF Frequency Sweep** menu is opened either in the **RF/A Mod** function block or using the MENU key under **RF/A Mod**.

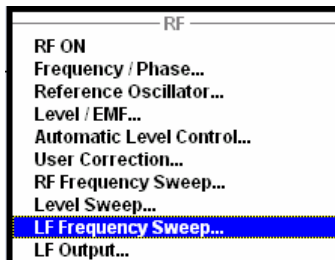

The top sections of the combined menu LF Output / LF Frequency Sweep provide access to the LF Sweep mode settings. The lower section provides access to the LF output settings, see section "[LF Generator and LF Output - LF Output](#)", page 4.125.

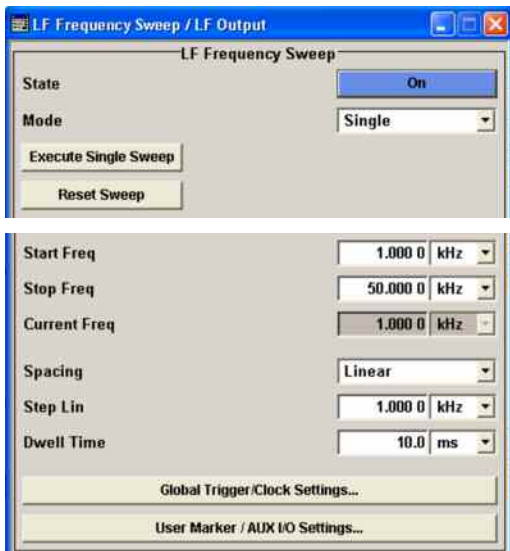

In the top section, the LF Sweep mode is activated and the sweep mode is selected. The buttons are used to reset the LF sweep (all sweep modes) or to execute the LF sweep (**Single** mode).

The sweep range, sweep spacing and dwell time are set in the bottom section.

In the top section, the LF Sweep mode is activated and the sweep mode is selected. The buttons are used to reset the LF sweep (all sweep modes) or to execute the LF sweep (**Single** mode).

**State - LF Sweep**

Activates LF Sweep mode.

**Note:**

*Activating the LF sweep automatically deactivates the list mode, RF sweep and level sweep in the same path.*

## Remote-control commands:

```
SOUR:LFO:FREQ:MODE SWE
```

```
SOUR:LFO:FREQ:MODE CW
```

**Mode - LF Sweep**

Selects the Sweep instrument operating mode and Sweep mode.

**Auto**

Sets an automatic repeated sweep cycle. If a different sweep mode was activated prior to the **Auto** mode, the cycle continues from the current sweep setting.

## Remote-control commands:

```
SOUR:LFO:SWE:FREQ:MODE AUTO
```

```
TRIG0:SWE:SOUR AUTO
```

```
SOUR:LFO:FREQ:MODE SWE
```

**Single**

Sets a single sweep cycle. The sweep is triggered by the **Execute Single Sweep** button.

If a different sweep mode was activated prior to the **Single** mode, the current sweep is stopped. The **Single** sweep always starts at the start frequency.

## Remote-control commands:

```
SOUR:LFO:SWE:FREQ:MODE AUTO
```

```
TRIG0:SWE:SOUR SING
```

```
SOUR:LFO:FREQ:MODE SWE
```

```
SOUR:LFO:SWE:FREQ:EXEC
```

**Step**

Sets a step-by-step sweep cycle. Each sweep step is triggered by a variation of the value in the **Current Freq** entry window.

If this mode is activated, the cursor moves to the value displayed for **Current Freq**. If a different sweep mode was activated prior to the **Step** mode, the current sweep is stopped. The **Step** sweep starts at the current LF frequency.

The **Reset** button resets the sweep to the start frequency.

## Remote-control command:

```
SOUR:LFO:SWE:FREQ:MODE MAN
```

```
SOUR:LFO:FREQ:MODE SWE
```

```
SOUR:LFO:SWE:FREQ:SPAC LIN
```

```
SOUR:LFO:SWE:FREQ:STEP:LIN 1E3
```

```
SOUR:LFO:FREQ:MAN 12 kHz
```

(the value entered with command  
`SOUR:LFO:SWE:FREQ:STEP:LIN|LOG` sets the  
 step width. The value entered with command  
`SOUR:LFO:FREQ:MAN` has no effect, the  
 command only sets the next sweep step. In remote  
 control only a step-by-step sweep from start to stop  
 frequency is possible)

**Extern Single**

Sets a single sweep cycle. The sweep is triggered  
 by an external trigger signal.

If a different sweep mode was activated prior to the  
**Extern Single** mode, the current sweep is  
 stopped. The **Extern Single** sweep always starts  
 at the start frequency.

The external trigger signal is input at the rear of the  
 instrument

Remote-control command:

```
SOUR:LFO:SWE:FREQ:MODE AUTO
TRIG0:SWE:SOUR EXT
SOUR:LFO:FREQ:MODE SWE
(External trigger)
```

**Extern Step**

Sets a step-by-step sweep cycle. Each sweep step  
 is triggered by an external trigger signal (trigger  
 source as described under **Extern Single**). The  
 step width corresponds to the step width set for the  
 rotary knob.

If a different sweep mode was activated prior to the  
**Extern Step** mode, the current sweep is stopped.  
 The **Extern Step** sweep always starts at the LF  
 start frequency.

Remote-control command:

```
SOUR:LFO:SWE:FREQ:MODE STEP
SOUR:LFO:SWE:FREQ:SPAC LIN
SOUR:LFO:SWE:FREQ:STEP LIN 1E3
TRIG0:SWE:SOUR EXT
SOUR:LFO:FREQ:MODE SWE
(External trigger)
```

**Execute Single Sweep - LF Sweep**

Triggers the sweep manually. A manual sweep can only be triggered if  
**Mode Single** is selected.

Remote-control commands

```
SOUR:LFO:SWE:FREQ:MODE AUTO
TRIG0:SWE:SOUR SING
SOUR:LFO:FREQ:MODE SWE
SOUR:LFO:SWE:FREQ:EXEC
```

**Reset Sweep - LF Sweep**

Resets the sweep. The start frequency is set and the next sweep  
 starts from there.

Remote-control command:

```
SWE:RES:ALL
```



The sweep range, sweep spacing and dwell time are set in the bottom section.

<b>Start Freq - LF Sweep</b>	<p>Sets the start frequency.</p> <p>Remote-control command: SOUR:LFO:FREQ:STAR 100kHz</p>
<b>Stop Freq - LF Sweep</b>	<p>Sets the stop frequency.</p> <p>Remote-control command: SOUR:LFO:FREQ:STOP 50kHz</p>
<b>Current Freq - LF Sweep</b>	<p>Displays the current frequency.</p> <p>If <b>Step</b> is set, the frequency for the next frequency step of the sweep is entered here.</p> <p>Remote-control command: SOUR:LFO:FREQ:MAN 15 kHz</p>
<b>Spacing - LF Sweep</b>	<p>Selects linear or logarithmic sweep spacing.</p> <p>Remote-control command: SOUR:LFO:SWE:FREQ:SPAC LIN   LOG</p>
<b>Shape - LF Frequency Sweep</b>	<p>Selects the cycle mode for a sweep sequence (shape) .</p>
	<p><b>Sawtooth</b>      One sweep runs from start to stop frequency. Each subsequent sweep starts at the start frequency, i.e. the shape of the sweep sequence resembles a sawtooth.</p> <p>Remote-control command: SOUR:LFO:SWE:FREQ:SHAP SAWT</p>
	<p><b>Triangle</b>      One sweep runs from start to stop frequency and back, i.e. the shape of the sweep resembles a triangle. Each subsequent sweep starts at the start frequency.</p> <p>Remote-control command: SOUR:LFO:SWE:FREQ:SHAP TRI</p>

- Step Lin/Log - LF Sweep** Sets the step width for the individual sweep steps. This entry is effective for all sweep modes.
- Step Lin** or **Step Log** is displayed depending on whether **Spacing Lin** or **Log** is selected.
- Step Lin** With the linear sweep, the step width is a fixed frequency value which is added to the current frequency. The linear step width is entered in Hz.
- Remote-control command:  
`SOUR:LFO:SWE:FREQ:STEP:LIN 1 kHz`
- Step Log** With the logarithmic sweep, the step width is a constant fraction of the current frequency. This fraction is added to the current frequency. The logarithmic step width is entered in %.
- Remote-control command:  
`SOUR:LFO:SWE:FREQ:STEP:LOG 1 PCT`
- Dwell Time - LF Sweep** Sets the dwell time. The dwell time determines the duration of the individual sweep steps.
- Remote-control command:  
`SOUR:LFO:SWE:FREQ:DWEL 10ms`
- Global Trigger/Clock Settings - LF Sweep** Open the **Global Trigger/Clock Settings** menu. This menu is used among other things for setting the polarity of the active slope of an applied instrument trigger
- See also section "[Global Trigger/Clock/External Input Settings - Setup-Environment](#)", on page 4.13.
- User Marker / AUX I/O - Global Settings** Calls the menu for configuring the AUX I/O and user interfaces (see the following section "[User Marker / AUX I/O - Setup-Environment-Global...Settings](#)").
- The pin assignment of the AUX I/O interface is shown in the **User Marker / AUX I/O Configuration** menu; the assignment of the USER pins 2...4 and USER 1 BNC connector can be changed.

## LF Generator and LF Output - LF Output

The internal LF generator is available as the internal source for the analog modulations AM, FM / PM and Pulse, and also as the signal source for the LF output at the rear of the instrument.

The frequency setting for the LF generator can be made both in the modulation menus and in the LF Output menu.

A change to the frequency of the LF generator automatically has an effect on modulation if the LF generator is selected as the modulation source (i.e. **Internal** is selected as **Source**).

The LF Sweep mode is activated in the **LF Sweep** menu.

### LF Output Menu

The **LF Output** menu is opened either in the **RF/A Mod** function block or using the **MENU** key under **RF/A Mod**.

The combined menu LF Output / LF Frequency Sweep provides access to the LF output configuration in the bottom section. The top sections provide access to the LF Sweep mode settings, see section "[LF Frequency Sweep Menu](#)", page 4.120.

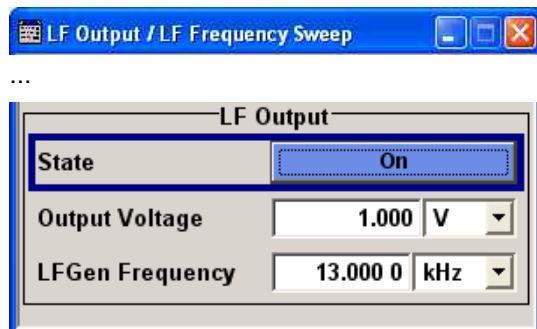

#### State - LF Output

Activates/deactivates the LF output. This setting has no effect on the modulations.

Remote-control command:

SOUR:LFO:STAT ON | OFF

#### Output Voltage - LF Output

Sets the output voltage of the LF output. The entered value determines the peak voltage.

Remote-control command:

SOUR:LFO:VOLT 1 V

#### LF Gen Frequency - LF Output

Sets the frequency of the LF generator. This setting affects all analog modulations which use the LF generator as the internal modulation source.

Remote-control command:

SOUR:LFO:FREQ 1 kHz

# Analog Modulations

The R&S Vector Signal Generator provides the analog modulations amplitude modulation (AM), broadband amplitude modulation (BB-AM) and pulse modulation (Pulse) for the basic unit (R&S SMJ + frequency option R&S SMJ-B10x) without additional equipment options.

The analog modulations frequency modulation (FM) and phase modulation (PhiM) require option R&S SMJ-B20 (FM/PhiM Modulator).

---

**Note:**

*The **MOD ON/OFF** key switches the modulations on and off. Pressing the key again restores the status that was active before the last switch-off. **MOD OFF** is displayed in the info line of the header next to the **Level** field.*

---

Remote-control command:

```
SOUR:MOD:ALL:STAT OFF
```

## Modulation Sources

For amplitude, pulse, frequency and phase modulation the internal and external modulation source can be used. For BB-AM only external modulation sources can be used.

### Internal Modulation Sources

The LF generator is available as internal modulation source. The generator supplies sinusoidal signals in the frequency range 0.1 Hz to 1 MHz (see also the section "[LF Generator and LF Output - LF Output](#)", page 4.125). With pulse modulation, the sinusoidal signal from the LF generator is formed internally into a rectangular signal used to actuate the pulse modulator.

### External Modulation Sources

The EXT MOD input at the rear of the instrument is provided as the external modulation source for amplitude, pulse, frequency and phase modulation. The external signal for broadband amplitude modulation is fed in via the I-input.

The external modulation signal at the EXT MOD input must have a voltage of  $U_s = 1 \text{ V}$  ( $U_{\text{eff}} = 0.707 \text{ V}$ ) in order to achieve the displayed modulation depth and range. The input voltage should not exceed  $1.1 V_s$ , otherwise modulation distortions might occur. With external pulse modulation, the switching point is max. 2.4 V and the voltage at the input should not exceed 5 V. The maximum modulation frequency is 10 MHz for frequency and phase modulation.

## Simultaneous Operation of Several Modulations or Other Operating Modes

The table shows the modulations and operating modes which can be activated simultaneously (+) or which deactivate each other (-).

	AM	FM	PHiM	Pulse	BB-AM	I/Q	DM	ARB
Amplitude modulation (AM)	/	+	+	+	-	-	-	-
Frequency modulation (FM)	+	/	-	+	+	+	+	+
Phase modulation (PHiM)	+	-	/	+	+	+	+	+
Pulse modulation	+	+	+	/	+	+	+	+
Broadband AM (BB-AM)	-	+	+	+	/	-	-	-
Vector modulation (I/Q)	-	+	+	+	-	/	-	-
Digital modulation (DM)	-	+	+	+	-	-	/	-
ARB	-	+	+	+	-	-	-	/

# Amplitude Modulation - AM

An internal or external source can be selected for amplitude modulation. The LF GEN modulation generator is available as the internal source. The I/Q modulator is used for amplitude modulation. The EXT MOD input connector for external feed is at the rear of the instrument. The coupling mode of the input (AC or DC) can be selected.

**Note:**

*It is not possible to use AM simultaneously with broadband AM, I/Q modulation, arbitrary waveform generation, digital modulation and digital standards.  
The AM modulation depth is limited by the maximum peak envelope power (PEP).*

## Amplitude Modulation Menu

The **Amplitude Modulation** menu is opened either in the **RF/A Mod** function block or using the **[MENU]** key under **RF/A Mod**.

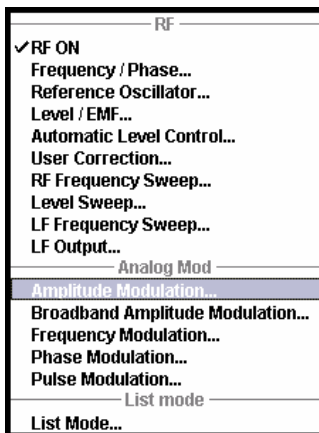

The top section of the combined menu Amplitude Modulation /Broadband AM provides access to the amplitude modulation settings. The lower section provides access to the broadband amplitude modulation settings, see section "[Broadband Amplitude Modulation - BB-AM](#)", page 4.131.



....

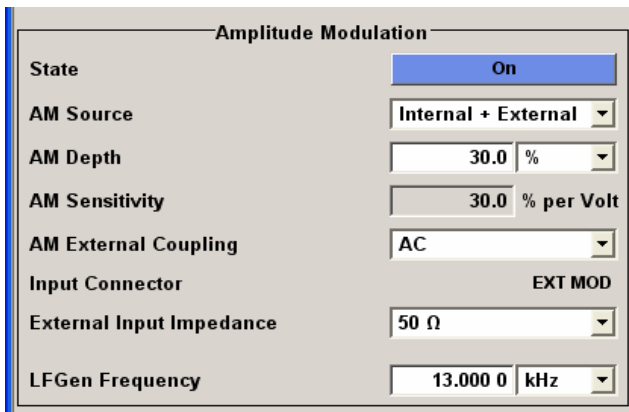

<b>State - AM</b>	<p>Activates/deactivates AM modulation.</p> <p>Activation of AM deactivates BB-AM, I/Q modulation, digital modulation and digital standards.</p> <p>Remote-control command: SOUR:AM:STAT ON</p>
<b>AM Source - AM</b>	<p>Selects the source for the AM signal.</p> <p><b>Internal</b>                Selects the internal LF generator as the source for AM modulation.</p> <p>Remote-control command: SOUR:AM:SOUR INT</p> <p><b>External</b>                Selects the external source. The external signal is input via the EXT MOD connector.</p> <p>Remote-control command: SOUR:AM:SOUR EXT</p> <p><b>Intern + Extern</b>        Selects the internal and external source at the same time.</p> <p>Remote-control command: SOUR:AM:SOUR INT,EXT</p>
<b>AM Depth</b>	<p>Sets the modulation depth in percent.</p> <p>Remote-control command: SOUR:AM:DEPT 20PCT</p>
<b>AM Sensitivity</b>	<p>Displays the input sensitivity of the EXT MOD input in %/V. The display only appears in the case of external modulation.</p> <p>The modulation depth entered under <b>AM Depth</b> is reached with 1 volt modulation of the input.</p> <p>Remote-control command: SOUR:AM:SENS? Response: "30"</p>
<b>AM External Coupling</b>	<p>Selects the coupling mode (AC or DC) for external feed.</p> <hr/> <p><b>Note:</b> <i>Coupling for external feed via input EXT MOD can be set independently for modulations AM, FM and PhiM.</i></p> <hr/> <p>Remote-control command: SOUR:AM:EXT:COUP AC</p>

**AM Input Connector**                      Displays the modulation input. The display only appears in the case of external modulation.

Remote-control command: n.a.

**External Input Impedance**              (Source External only) Selects the impedance for external feed via the EXT MOD input. Selection 50 Ohm and high (>100 kOhm) is available.

---

**Note:**

*This setting affects all analog modulations which use the external modulation source.*

---

Remote-control command:  
SOUR:INP:MOD:IMP G50

**LF Gen Frequency - AM**                      Sets the frequency of the LF generator.  
  
This setting affects all analog modulations which use the LF generator as the internal modulation source..

Remote-control command:  
SOUR:LFO:FREQ 1E3



## Broadband Amplitude Modulation - BB-AM

With broadband amplitude modulation the I/Q modulator is used for amplitude modulation. An external source is always used. The modulation input is the I-input of the I/Q modulator. The sensitivity for broadband amplitude modulation is 0.25V / 100% modulation depth. It is not possible to set a modulation depth for BB-AM.

### Note:

*It is not possible to use BB-AM simultaneously with AM, I/Q modulation, ARB, digital modulation and digital standards.*

*The upper level limit for BB-AM is the same as that for I/Q modulation. PEP is up to 6 dB above the display value, depending on the modulation depth.*

## Broadband Amplitude Modulation Menu

The **Broadband Amplitude Modulation** menu is opened either in the **RF/A Mod** function block or using the **MENU** key under **RF/A Mod**.

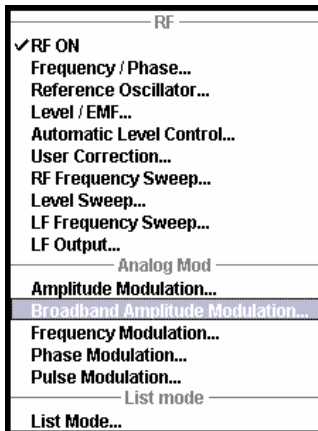

The combined menu Amplitude Modulation /Broadband AM provides access to the Broadband AM configuration in the bottom section. The top section provides access to the amplitude modulation settings, see section "[Amplitude Modulation - AM](#)", page 4.128.



....

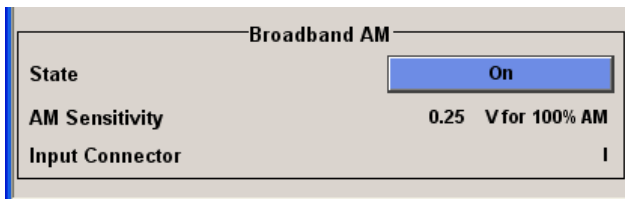

**State - BB-AM**

Activates/deactivates broadband AM modulation. Activation of broadband AM deactivates AM, I/Q modulation, digital modulation and digital standards.

Remote-control command:  
SOUR:AM:BBAN:STAT ON

**AM Sensitivity - BB-AM**

Displays the input sensitivity of the I IN input in V/100% modulation depth. The input sensitivity cannot be influenced in the case of broadband AM since it is not possible to set the range.

Remote-control command:  
SOUR:AM:BBAN:SENS?  
Response: "0.25"

**Input Connector - BB-AM**

Displays the modulation input (I-input connector of the I/Q modulator).

Remote-control command: n.a.

## Pulse Modulation

Pulse modulation is available for the basic unit (R&S SMJ + frequency option R&S SMJ-B10x) without additional equipment options.

An internal or external source can be selected for pulse modulation. A simple rectangular signal with selectable repetition frequency is available as the internal signal. This signal is formed from the sinusoidal signal supplied by the LF generator.

The external signal is input via the EXT MOD connector at the rear of the instrument. The polarity of the external pulse modulation can be selected. If Polarity is set to Normal, the RF level is ON if the level is HIGH at the modulation input.

## Pulse Modulation Menu

The **Pulse Modulation** menu is opened either in the **RF/A Mod** function block or using the **MENU** key under **RF/A Mod**.



The menu differs according to the selected internal or external modulation source.

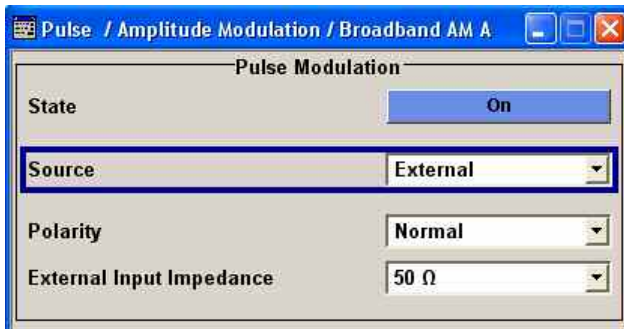

### State - Pulse Modulation

Activates/deactivates pulse modulation. Activation of pulse modulation deactivates ALC and power ramping.

Remote-control command:

SOUR:PULM:STAT ON | OFF

<b>Source - Pulse Modulation</b>	<p>Selects the source for the pulse modulation signal.</p> <p><b>Internal</b>                      Selects the internal source. The LF generator generates a rectangular pulse with the set frequency.</p> <p>                                         Remote-control command: SOUR:PULM:SOUR INT</p> <p><b>External</b>                      Selects the external source. The external modulation signal is input via the EXT MOD connector.</p> <p>                                         Remote-control command: SOUR:PULM:SOUR EXT</p>
<b>LFGGen Frequency - Pulse Modulation</b>	<p>Sets the repetition frequency of the internal signal. This setting affects all analog modulations which use the LF generator as the internal modulation source.</p> <p>Remote-control command: SOUR:LFO:FREQ 20 kHz</p>
<b>Pulse External Input Impedance</b>	<p>(Source External only) Selects the impedance for external feed via the EXT MOD input. Selection 50 Ohm and high (&gt;100 kOhm) is available.</p> <p>This setting affects all analog modulations which use the external modulation source.</p> <p>Remote-control command: SOUR:INP:MOD:IMP G50</p>
<b>Polarity - Pulse Modulation</b>	<p>Selects the polarity of the modulation signal.</p> <p><b>Normal</b>                      The RF signal is ON while the level is HIGH.</p> <p>                                         Remote-control command: SOUR:PULM:POL NORM</p> <p><b>Inverted</b>                      The RF signal is ON while the level is LOW.</p> <p>                                         Remote-control command: SOUR:PULM:POL INV</p>

## Frequency Modulation - FM

Frequency modulation requires option R&S SMJ-B20 (FM/PhiM Modulator).

An internal and/or external source can be selected for frequency modulation. The LF GEN modulation generator is available as the internal source.

The EXT MOD input connector for external feed is at the rear of the instrument. The coupling mode of the input (AC or DC) and 50 Ohm or high (> 10 kOhm) impedance can be selected.

---

**Note:**

*It is not possible to use frequency modulation simultaneously with phase modulation.*

---

### Frequency Modulation Menu

The **Frequency Modulation** menu is opened either in the **RF/A Mod** function block or using the MENU key under **RF/A Mod**.

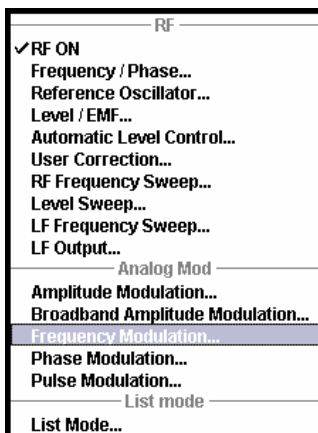

The middle section of the combined menu Pulse/Frequency/Phase Modulation provides access to the frequency modulation settings. The upper section provides access to the pulse modulation settings, see section "[Pulse Modulation](#)", page 4.133, the lower section to phase modulation, see section "[Phase Modulation - PhiM](#)", page 4.139.

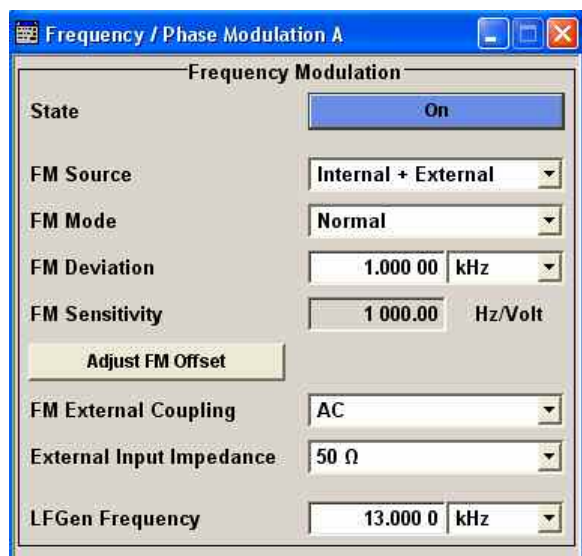

**State - FM**

Activates/deactivates FM modulation.

Activation of FM deactivates phase modulation.

Remote-control command:

```
SOUR:FM:STAT ON
```

**FM Source - FM**

Selects the source for the FM signal.

**Internal**

Selects the internal LF generator as the source for FM modulation.

Remote-control command:

```
SOUR:FM:SOUR INT
```

**External**

Selects the external source. The external signal is input via the EXT MOD connector.

Remote-control command:

```
SOUR:FM:SOUR EXT
```

**Internal + External**

Selects the internal and external source at the same time.

Remote-control command:

```
SOUR:FM:SOUR INT,EXT
```

**FM Mode - FM**

Selects the mode for the frequency modulation.

**Normal**

The maximum range for modulation bandwidth and FM deviation is available.

Remote-control command:

```
SOUR:FM:MODE NORM
```

**FM Deviation - FM**

Sets the modulation depth in Hz.

The maximal deviation depends on the RF frequency set and the selected modulation mode (see data sheet). It is possible to enter a deviation that is too high for a certain RF frequency or to vary the RF frequency to a range in which the deviation can no longer be set. In this case the maximally possible deviation is set and an error message is displayed.

Remote-control command:

SOUR:FM:DEV 10kHz

**FM Sensitivity - FM**

Displays the input sensitivity of the EXT MOD input in Hz/V. The display only appears in the case of external modulation.

The modulation depth entered under **FM Depth** is reached with 1 volt (=  $U_{\text{peak}}$ ) of the input signal.

**Note:**

*The input voltage should not exceed 1.1  $V_p$  otherwise modulation distortions might occur.*

Remote-control command:

SOUR:FM:SENS?

Response: "1E3"

**Adjust FM Offset - FM**

Starts the adjustment for the FM/PhiM modulator. The option is adjusted with respect to DC-offset.

Remote-control command:

CAL:FMOF?

**FM External Coupling - FM**

(Source External only) Selects the coupling mode (AC or DC) for external feed.

**Note:**

*Coupling for external feed via input EXT MOD can be set independently for modulations AM, FM and PhiM.*

**AC**

The d.c. voltage content is separated from the modulation signal.

Remote-control command:

SOUR:FM:EXT:COUP AC

**DC**

The modulation signal is not altered.

Remote-control command:

SOUR:FM:EXT:COUP DC

**External Input Impedance** (Source External only) Selects the impedance for external feed via the EXT MOD input. Selection 50 Ohm and high (>100 kOhm) is available.

---

**Note:**

*This setting affects all analog modulations which use the external modulation source.*

---

Remote-control command:

SOUR:INP:MOD:IMP G50

**LF Gen Frequency - FM** (Source Internal only) Sets the frequency of the LF generator.

This setting affects all analog modulations which use the LF generator as the internal modulation source..

Remote-control command:

SOUR:LFO:FREQ 1E3



## Phase Modulation - PhiM

Phase modulation requires option R&S SMJ-B20 (FM/PhiM Modulator).

### Note:

*It is not possible to use phase modulation simultaneously with frequency modulation.*

An internal and/or external source can be selected for phase modulation. The LF GEN modulation generator is available as the internal source.

The EXT MOD input connector for external feed is at the rear of the instrument. The coupling mode of the input (AC or DC) and the impedance (50 Ohm or < 1kOhm) can be set.

Selection between two modulation modes is possible:

- **High Bandwidth** mode with full setting range for modulation bandwidth and limited PhiM deviation.
- **High Deviation** mode with full setting range for PhiM deviation and a reduced setting range for modulation bandwidth. Phase noise is reduced in the lower modulation frequency range (compared to **High Bandwidth** mode).

## Phase Modulation Menu

The **Phase Modulation** menu is opened either in the **RF/A Mod** function block or using the MENU key under **RF/A Mod**.

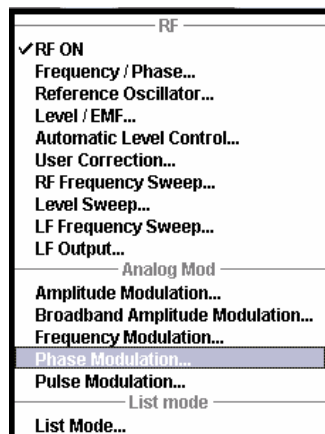

The lower section of the combined menu Pulse/Frequency/Phase Modulation provides access to the phase modulation settings. The upper section provides access to the pulse modulation settings, see section "[Pulse Modulation](#)", page 4.133, the middle section to frequency modulation, see section "[Frequency Modulation - FM](#)", page 4.135.



....

Phase Modulation	
State	<input type="button" value="On"/>
ΦM Source	Internal + External
ΦM Mode	High Bandwidth
ΦM Deviation	1.000 000 rad
ΦM Sensitivity	1.000 000 rad per Volt
ΦM External Coupling	AC
External Input Impedance	50 Ω
LFGen Frequency	13.000 0 kHz

**State - PhiM**

Activates/deactivates PhiM modulation.

Activation of PhiM deactivates frequency modulation.

Remote-control command:

SOUR:PM:STAT ON

**PhiM Source**

Selects the source for the PhiM signal.

**Internal**

Selects the internal LF generator as the source for PhiM modulation.

Remote-control command:

SOUR:PM:SOUR INT

**External**

Selects the external source. The external signal is input via the EXT MOD connector.

Remote-control command:

SOUR:PM:SOUR EXT

**Internal + External**

Selects the internal and external source at the same time.

Remote-control command:

SOUR:PM:SOUR INT,EXT

**PhiM Mode**

Selects the mode for the phase modulation.

**High Bandwidth**

The maximum range for modulation bandwidth is available. However, phase noise is increased for low frequencies. The range for PhiM deviation is limited.

This mode is recommended for high modulation frequencies.

Remote-control command:

SOUR:PM:MODE HBAN

**High Deviation** The maximum range for PhiM deviation is available. Phase noise is improved for low frequencies compared to **High Bandwidth** mode. The range for modulation frequency is limited (see data sheet).

This mode is recommended for low modulation frequencies and/or high PhiM deviation.

Remote-control command:

SOUR:PM:MODE HDEV

### PhiM Deviation

Sets the modulation depth in RAD or degrees.

The maximal deviation depends on the RF frequency set and the selected modulation mode (see data sheet). It is possible to enter a deviation that is too high for a certain RF frequency or to vary the RF frequency to a range in which the deviation can no longer be set. In this case the maximally possible deviation is set and an error message is displayed.

Remote-control command:

SOUR:PM:DEV 10

### PhiM Sensitivity

Displays the input sensitivity of the EXT MOD input in RAD/V. The display only appears in the case of external modulation.

The modulation depth entered under **PhiM Depth** is reached with 1 volt ( $=U_{\text{peak}}$ ) of the input signal.

---

**Note:**

*The input voltage should not exceed  $1.1 V_p$  otherwise modulation distortions might occur.*

---

Remote-control command:

SOUR:PM:SENS?

### PhiM External Coupling

Selects the coupling mode (AC or DC) for external feed.

---

**Note:**

*Coupling for external feed via input EXT MOD can be set independently for modulations AM, FM and PhiM.*

---

#### AC

The d.c. voltage content is separated from the modulation signal.

Remote-control command:

SOUR:PM:EXT:COUP AC

#### DC

The modulation signal is not altered.

Remote-control command:

SOUR:PM:EXT:COUP DC

**External Input Impedance** Selects the impedance for external feed via the EXT MOD input. Selection 50 Ohm and high impedance (>100 kOhm) is available.

---

**Note:**

*This setting affects all analog modulations which use the external modulation source.*

---

Remote-control command:

SOUR:INP:MOD:IMP G50

**LF Gen Frequency - PhiM** (Source Internal only) Sets the frequency of the LF generator.

This setting affects all analog modulations which use the LF generator as the internal modulation source.

Remote-control command:

SOUR:LFO:FREQ 1E3

# I/Q Modulation

## Introduction - I/Q Modulation

The R&S Vector Signal Generator offers I/Q modulation with external analog I/Q signals as well as internal digital signals.

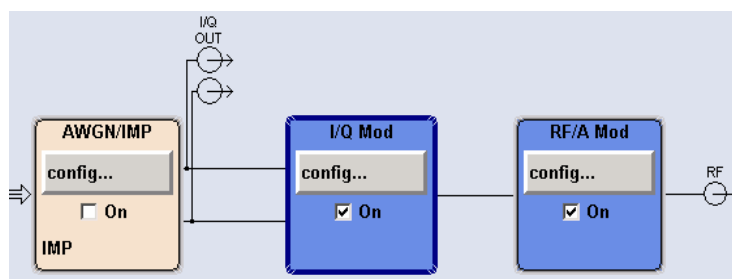

I/Q modulation with an external analog I/Q signal is possible for the basic unit (R&S SMJ with frequency option R&S SMJ-B10x) without additional equipment options. The basic equipment configuration for generating an internal baseband signal includes the options R&S SMJ-B13 (Baseband Main Module) and R&S SMJ-B9/B10/B11 (Unicod and ARB).

The external signal is input via the **I** and **Q** connector and transferred directly to the I/Q modulator (**I/Q Mod** function block).

The internally generated baseband signal is configured in the **Baseband** function block (see the section "[Baseband Signal - Baseband](#)"). Before the signal is fed into the I/Q modulator, noise can be added and/or the signal can be impaired. Impairment at this point along the signal flow is offered to allow a signal to be output at the I/Q-OUT outputs (a signal which, for example, compensates signal distortion in a connected test object (DUT)).

Impairment is integrated in the option R&S SMJ-B13 (Baseband Main Module). The generation of noise requires the option R&S SMJ-K62 (AWGN).

The input signal of the I/Q modulator is selected in the **I/Q Mod** function block (see the following section "[I/Q Modulator - I/Q MOD Function Block](#)", page 4.144).

If the external analog signal is fed into the I/Q modulator, the input signal "**Analog Wideband I/Q In**" must be selected. The maximum RF bandwidth is available (see data sheet).

If the internally generated baseband signal is input, the input signal "**Internal Baseband I/Q In**" must be selected. The RF bandwidth is reduced (see data sheet).

Impairments can also be set in the I/Q Mod menu to allow an externally applied analog I/Q signal to be impaired. An internal baseband signal can thus be impaired both digital (in the Impairment block in the Impairment menu) and analog in the I/Q modulator. If impairments are set in both menus, they superimpose each other in the signal.

# I/Q Modulator - I/Q MOD Function Block

The input signal of the I/Q modulator is selected and the **I/Q Settings** menu opened in the **I/Q Mod** function block.

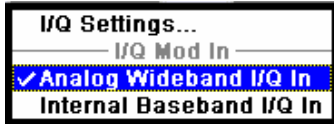

The **I/Q Settings** menu containing the modulation settings is opened in the top section.

The input signal is selected in the **I/Q Mod In** section and also in the **I/Q Settings** menu.

See following section "[I/Q Settings Menu](#)", page 4.144

## I/Q Settings Menu

The menu for setting the I/Q modulation parameters is opened either in the **I/Q Mod** function block or in the menu with the same name which is opened using the **MENU** key.

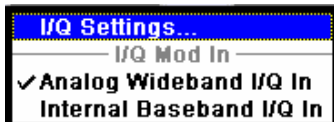

**Notes:**

*It is not possible to use I/Q modulation with an external analog signal (**Analog Wideband I/Q In**) simultaneously with AM, broadband AM, digital modulation and digital standards, noise, arbitrary waveform generation and multi carrier CW.*

*System error correction of the I/Q modulator permits precise and repeatable measurements. The correction routine should be called in the case of temperature fluctuations of several degrees. The routine is called in the **Internal Adjustment** submenu, **SETUP** key - **System** menu .*

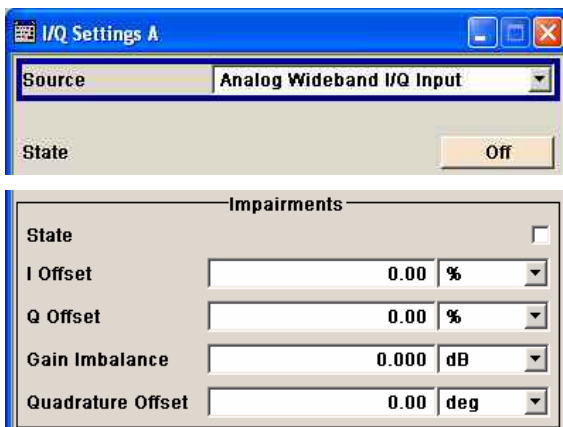

I/Q modulation is activated and the source entered in the top section of the menu

I/Q impairment for specific impairment of the I/Q modulation is set in the **Impairments** section.



I/Q control can be swapped in the lower section of the menu and the optimized settings for wideband modulation signals can be activated.

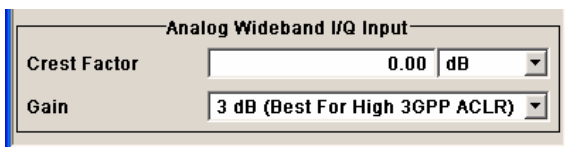

The bottom section of the menu differs depending on the selected input signal (**Analog Wideband I/Q Input** or **Internal Baseband**).

The crest factor is input for the external signal.

The gain is selected for the internal and external signal.

I/Q modulation is activated and the source entered in the top section of the menu.

**IQ Source - I/Q Mod**

Selects the input signal for the I/Q modulator.

**Analog Wideband I/Q In**

Selects an external analog signal as the input signal. The signal must be applied at the inputs I and Q.

Remote-control command:

SOUR:IQ:SOUR ANAL

**Internal Baseband I/Q In**

Selects the internal baseband signal as the input signal. This setting requires the additional equipment options for generating the various baseband signals.

Remote-control command:

SOUR:IQ:SOUR BAS

**State - I/Q Mod**

Activates/deactivates I/Q modulation.

If **Analog Wideband I/Q In** is selected, the I/Q modulator is also deactivated and activated.

If **Internal Baseband I/Q In** is selected, the I/Q modulator is always activated automatically as soon as signal generation is activated in the **Baseband** block. It can, however, be deactivated later, e.g. if only the baseband signal which is output at the I/Q outputs is relevant.

Remote-control command:

SOUR:IQ:STAT ON | OFF

I/Q impairment for specific impairment of the I/Q modulation is set in the **Impairments** section.

**State - Impairments I/Q Mod**

Activates/deactivates I/Q impairment.

If activated, the settings for leakage, I/Q imbalance and quadrature offset become effective.

Whether or not I/Q impairment is activated is indicated in the function block.

**Note:**

*It is advisable to switch automatic level control to the Sample&Hold mode, as otherwise level errors may occur (RF / Ana Mod – Automatic Level Control menu).*

Remote-control command:

SOUR:IQ:IMP:STAT ON | OFF

**Offset - I/Q Mod**

Sets the carrier offset (in percent) of the amplitudes (scaled to the peak envelope power (PEP) for the I and/or Q signal component.

An ideal I/Q modulator suppresses the carrier offset completely (offset = 0 percent). If an offset value is entered for a component, a carrier offset with fixed amplitude is added to the signal. In the diagram, all I values or Q values are offset by a fixed amplitude value depending on the entered percentage.

Effect of offset for the I component:

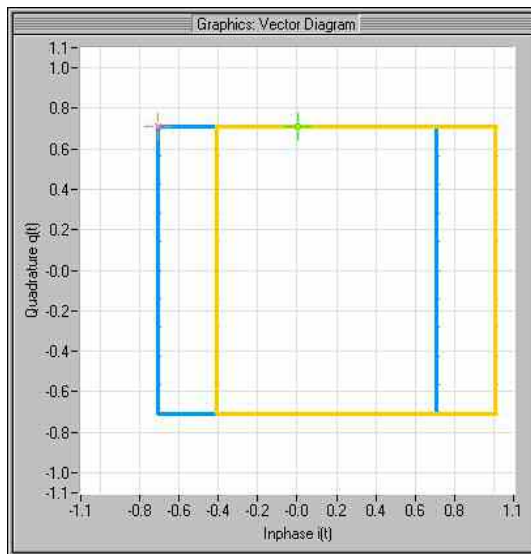



Effect of offset for the Q component:

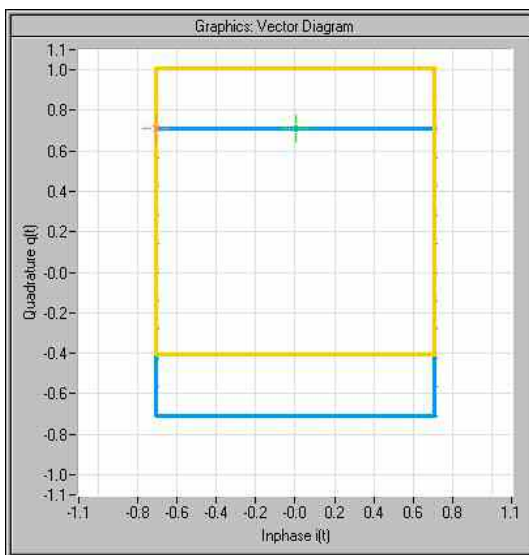

Effect of an identical offset for both signal components:

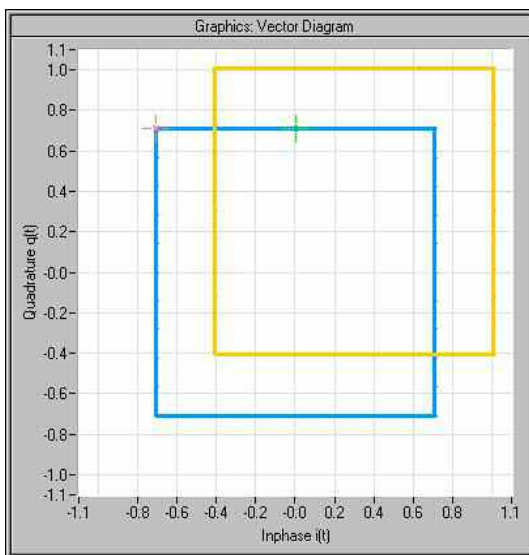

Remote-control command:

SOUR:IQ:IMP:LEAK:I 10PCT

SOUR:IQ:IMP:LEAK:Q 10PCT

**Gain Imbalance - I/Q Mod**

Sets the imbalance of the I and Q vector.

The entry is made in dB (default) or %, where 1 dB offset is roughly 12 % according to the following:

$$\text{Imbalance [dB]} = 20\log ( | \text{Gain}_Q | / | \text{Gain}_I | )$$

An ideal I/Q modulator amplifies the I and Q signal path by exactly the same degree. The imbalance corresponds to the difference in amplification of the I and Q channel and therefore to the difference in amplitude of the signal components. In the vector diagram, the length of the I vector changes relative to the length of the Q vector.

Positive values mean that the Q vector is amplified more than the I vector by the corresponding percentage.

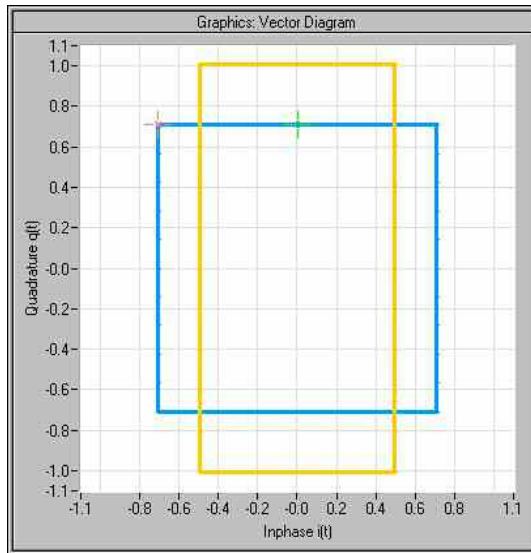

Negative values mean that the I vector is amplified more than the Q vector by the corresponding percentage:

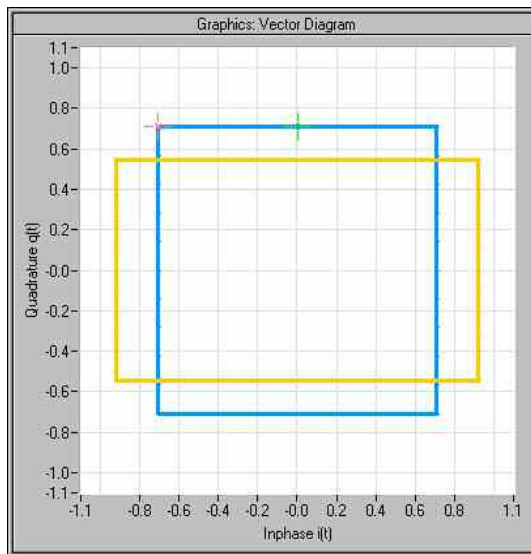

Remote-control command:

SOUR:IQ:IMP:IQR:MAGN -5PCT

**Quadrature Offset - I/Q Mod** Sets the quadrature offset.

An ideal I/Q modulator sets the phase angle to exactly 90 degrees. With a quadrature offset, the phase angle between the I and Q vector deviates from the ideal 90 degrees, the amplitudes of both components are of the same size. In the vector diagram, the quadrature offset causes the coordinate system to shift.

A positive quadrature offset means a phase angle greater than 90 degrees:

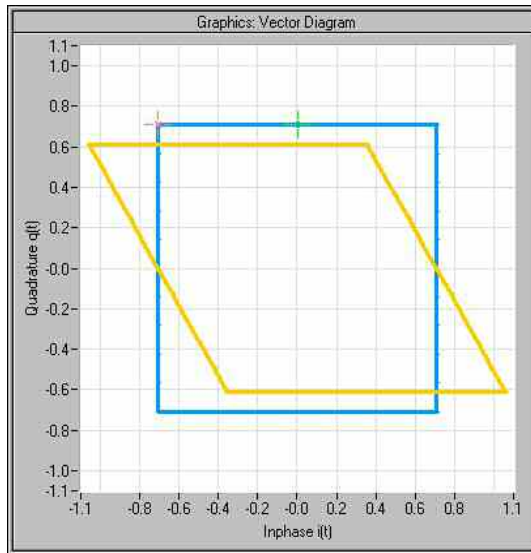

A negative quadrature offset means a phase angle less than 90 degrees:

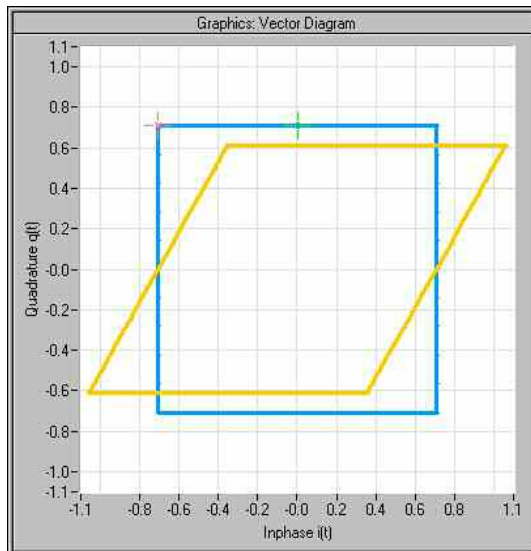

**Remote-control command:**

SOUR:IQ:IMP:QUAD:ANGL 4DEG

The I/Q control can be swapped and the optimized setting for wideband signals can be selected in the middle section of the menu.

### I/Q-Swap - I/Q Mod

Selects normal or swapped I/Q control for an external analog signal. The modulation sidebands are inverted by swapping the I and Q signals.

This parameter enables I/Q modulation to be performed on signals according to IS2000 (cdma2000 standard) and the majority of all other standards. As a result, an I/Q demodulator defined according to IS2000 can also be used for demodulating the generated signals.

The I/Q modulator defined in the IS2000 standard differs from the definition in the R&S Vector Signal Generator. The definition on which the R&S Vector Signal Generator is based is used by virtually all digital communication standards (except IS95 and IS2000).

In the final step, the filtered I/Q signal is modulated to the desired RF in a different way in the I/Q modulator:

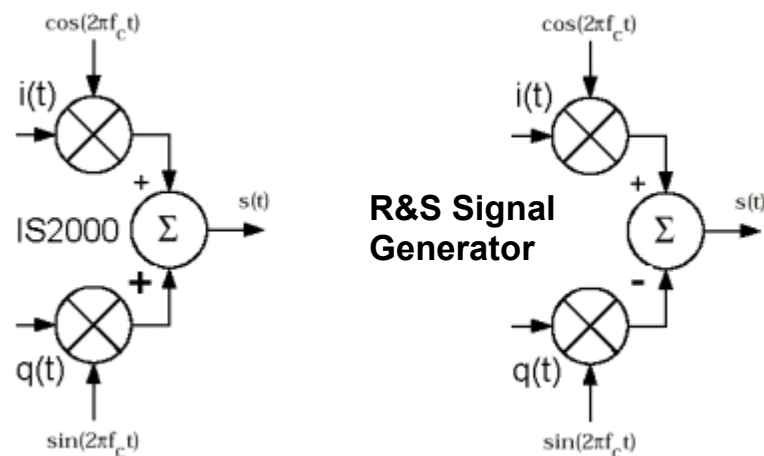

Figure 4-1 Definition of I/Q modulator in IS2000 and R&S Vector Signal Generator

According to IS2000, the RF signal  $s(t)$  is derived from the baseband I/Q signal as follows:

$$s(t) = i(t) \cos(2\pi f_c t) + q(t) \sin(2\pi f_c t)$$

The R&S Vector Signal Generator is based on the following definition:

$$s(t) = i(t) \cos(2\pi f_c t) - q(t) \sin(2\pi f_c t)$$

**I/Q Swap** must now be set to **On** so that an I/Q modulator defined according to IS2000 can cope with the RF signal generated by the R&S Vector Signal Generator.

**Off** I/Q control is normal.  
Remote-control command:  
SOUR:IQ:SWAP:STAT OFF

**On** The I and Q signals are swapped.  
Remote-control command:  
SOUR:IQ:SWAP:STAT ON

**I/Q-Wideband - I/Q Mod** Optimized setting for wideband modulation signals (>5 MHz).

The modulation frequency response is decreased at the expense of poorer harmonic suppression. This is achieved by shifting the switching frequencies of the lowpass filters in the output section.

Remote-control command:  
SOUR:IQ:WBST ON

In the bottom section of the menu the crest factor is input for the external signal and the gain is selected for the internal and external signal (**Analog Wideband I/Q Input** or **Internal Baseband**).

**Crest Factor - I/Q Mod** (Analog Wideband I/Q Input only) Sets the crest factor of the external analog signal.

The crest factor gives the difference in level between the peak envelope power (PEP) and average power value (RMS) in dB.

This value is necessary to allow the correct output power to be generated at the RF output. When the set output power is generated, the R&S Vector Signal Generator uses this value to compensate the average power which is lower compared to the peak power.

The maximum input voltage at the I/Q input is equated to the peak power and is used as the "reference" for setting the level of the output signal. Since the signal does not usually supply the peak power at a constant level and instead supplies a lower average power, the crest factor specifies how many dB have to be added internally so that the correct output power is achieved.

Remote-control command:  
SOUR:IQ:CRES 10

**Baseband Gain-Gain - I/Q Mod**

Optimizes the modulation of the I/Q modulator for any measurement requirement.

The modulation is determined by selecting the gain.

**Note:**

*The remote-control commands to be used depend on the selected I/Q input signal (SOURce:IQ:SOURce ANALog | BASEband). For the Analog Wideband I/Q input signal (SOURce:IQ:SOURce ANALog), the commands of system SOURce:IQ:GAIN are valid. For the internal or external Baseband I/Q input signal (SOURce:IQ:SOURce BASEband), the commands of system SOURce:BB:IQGain are valid.*

**Auto****(digital baseband signal only)**

With this setting, the modulation is automatically optimized for the internally set baseband signal.

Remote-control command:

SOUR:BB:IQG AUTO (digital I/Q signal)

**- 3dB (Low Distortion)**

Activates -3 dB gain. With this setting, signal distortions are minimized.

Remote-control command:

SOUR:IQ:GAIN DBM3 (analog I/Q signal)

SOUR:BB:IQG DBM3 (digital I/Q signal)

**0 dB (Standard)**

Activates 0 dB gain

Remote-control command:

SOUR:IQ:GAIN DB0 (analog I/Q signal)

SOUR:BB:IQG DB0 (digital I/Q signal)

**3 dB (High 3GPP ACLR)**

Activates 3 dB gain. This setting is recommended for 3GPP signals with very high adjacent channel power ratio (ACPR).

Remote-control command:

SOUR:IQ:GAIN DB3 (analog I/Q signal)

SOUR:BB:IQG DB3 (digital I/Q signal)

**6dB (Low Noise)**

Activates 6 dB gain. With this setting, signal noise is minimized.

Remote-control command:

SOUR:IQ:GAIN DB6 (analog I/Q signal)

SOUR:BB:IQG DB6 (digital I/Q signal)

# Impairment of Digital I/Q Signal and Noise Generator - AWGN-IMP Block

The R&S Vector Signal Generator allows the digital I/Q signal to be impaired before it is passed on to the I/Q modulator, and also noise to be added to the signal. The noise generator can also be used to generate a pure noise signal.

These settings are available in the block diagram in the "**AWGN / IMP**" function block as well as in the menu with the same name which is opened using the **[MENU]** key .

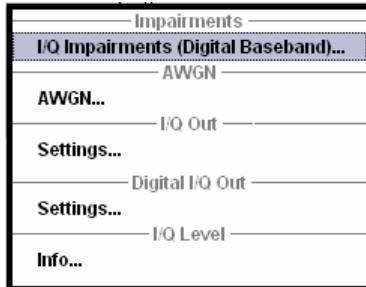

Selecting the menu item **I/Q Impairments (Digital Baseband)...** the I/Q impairment settings dialog opens. This dialog covers the settings for I/Q impairment, like carrier leakage, imbalance and quadrature offset, as well as the settings for correcting signal distortions for the RF output.

With **AWGN...** the AWGN settings dialog opens, containing the settings of the RFI signal generator, noise level configuration and CW interfering parameters.

**Settings...** opens the analog I/Q Output dialog or, in section Digital I/Q Out, the digital I/Q Output dialog, respectively, for setting the parameters of the I/Q output signal.

In case of two-path instruments, the analog I/Q output signal can be assigned either to path A or path B.

**Info...** opens a dialog, displaying information on the baseband signal level.

The equipment options for the basic unit (R&S SMJ with frequency option R&S SMJ-B10x) include the option R&S SMJ-B13 (Baseband Main Module) for **Impairments** and the option R&S SMJ-K62 (Noise Generator) for **AWGN**.

The single ended or differential output (option R&S SMJ-B16, Differential Output) is configured in the **I/Q Out** dialog.

## Introduction - Impairments

Impairment of the digital I/Q signal prior to input into the I/Q modulator can be used, for example, to compensate the distortion of a test object or to check the effect of a disturbed signal on a test object. For this purpose, the I/Q signal can be output at the **I/Q Out** outputs. On the other hand, the I/Q impairments used internally for compensating signal distortion can be deactivated by the I/Q modulator in order to, for example, test its own baseband components.

---

### Note:

*In addition to impairment of the digital I/Q signal, the R&S Vector Signal Generator also allows impairment of the analog signal to be set in the I/Q modulator. The relevant settings are made in the **I/Q Mod** function block (see the section "[I/Q Modulation](#)", on page 4.144).*

---

## Impairment Settings Menu

The **Impairment Settings** menu for setting the digital I/Q impairments is opened either in the **AWGN / IMP** function block or using the **MENU** key under **AWGN / IMP**.

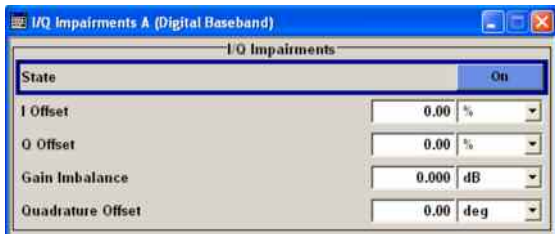
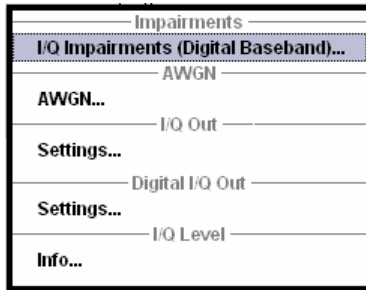

**I/Q impairment** is activated and set in the I/Q Impairments section.



**Internal compensation** of signal distortions of the **RF output** can be activated or deactivated.

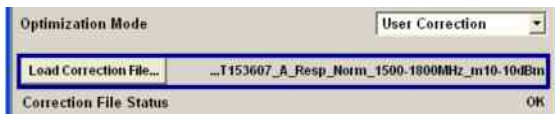

Correction files for **user defined correction of the RF output**, supported by the R&S SMx RF and Baseband Correction Toolkit (option SMx-K63) can be loaded in the lower section of the dialog box.

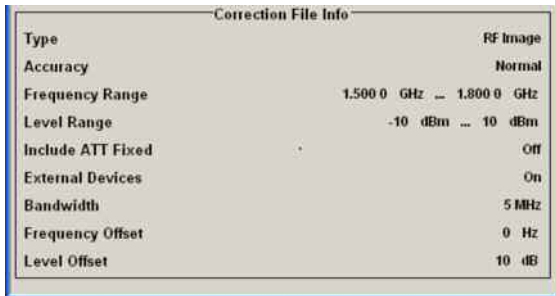

The SMx-K63 File Info section displays header **information** on the loaded **frequency response correction file**.

In the **I/Q Impairments** section the parameters for carrier leakage, imbalance and quadrature offset can be set and I/Q impairment is activated.

**State - Digital Impairments** Activates/deactivates digital I/Q impairment.

When activated, the settings for carrier leakage, I/Q imbalance and quadrature offset become effective.

Internal predistortion for compensating the I/Q modulator is not influenced by this setting.

Remote-control command:

SOUR:BB:IMP:STAT ON



**I/Q Offset - Digital Impairments**

Sets the carrier leakage (in percent) of the amplitudes (scaled to the peak envelope power (PEP)) for the I and/or Q signal component.

An ideal I/Q modulator suppresses the carrier leakage completely (offset = 0 percent). If an offset is entered for a component, a carrier leakage with fixed amplitude is added to the signal. In the diagram, all I values or Q values are offset by a fixed amplitude value depending on the entered percentage.

Effect of offset for the I component:

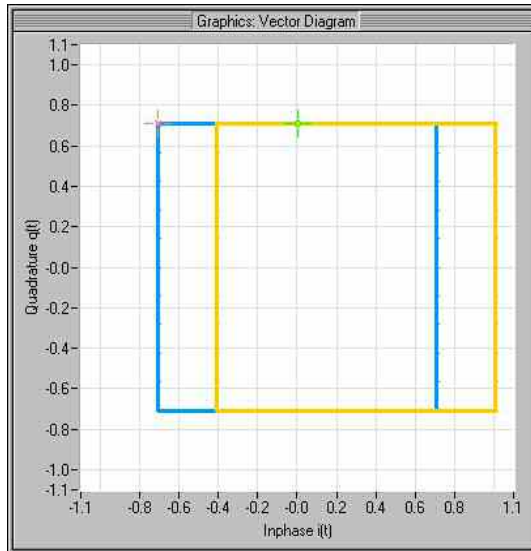

Effect of offset for the Q component:

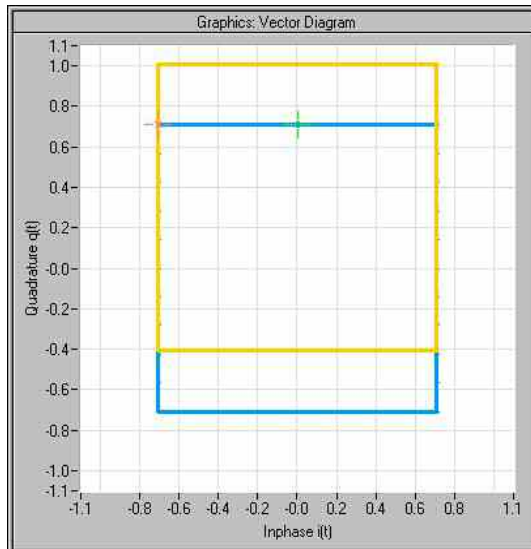

Effect of an identical offsets for both signal components:

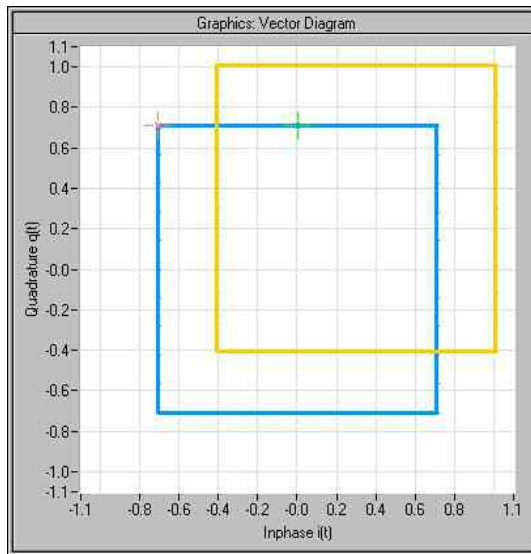

Remote-control commands:

SOUR:BB:IMP:LEAK:I 6PCT

SOUR:BB:IMP:LEAK:Q 6PCT

**Gain Imbalance - Digital Impairments**

Sets the imbalance of the I and Q vector.

The entry is made in dB (default) or %, where 1 dB offset is roughly 12 % according to the following:

$$\text{Imbalance [dB]} = 20\log ( | \text{Gain}_Q | / | \text{Gain}_I | )$$

An ideal I/Q modulator amplifies the I and Q signal path by exactly the same degree. The imbalance corresponds to the difference in amplification of the I and Q channel and therefore to the difference in amplitude of the signal components. In the vector diagram, the length of the I vector changes relative to the length of the Q vector.

Positive values mean that the Q vector is amplified more than the I vector by the corresponding percentage:

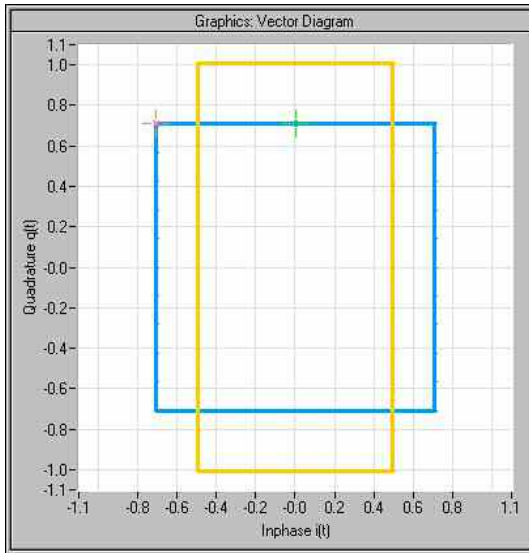

Negative values mean that the I vector is amplified more than the Q vector by the corresponding percentage:

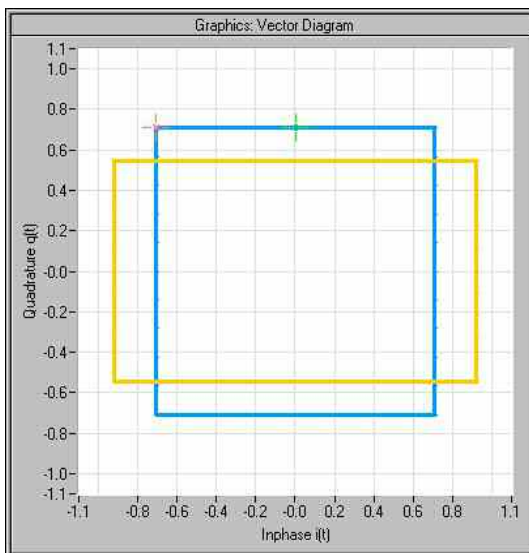

Remote-control command:  
 SOUR:BB:IMP:IQR 0.1

**Quadrature Offset - Digital Impairments**

Sets the quadrature offset.

An ideal I/Q modulator sets the phase angle to exactly 90 degrees. With a quadrature offset, the phase angle between the I and Q vector deviates from the ideal 90 degrees, the amplitudes of both components are of the same size. In the vector diagram, the quadrature offset causes the coordinate system to shift.

A positive quadrature offset means a phase angle greater than 90 degrees:

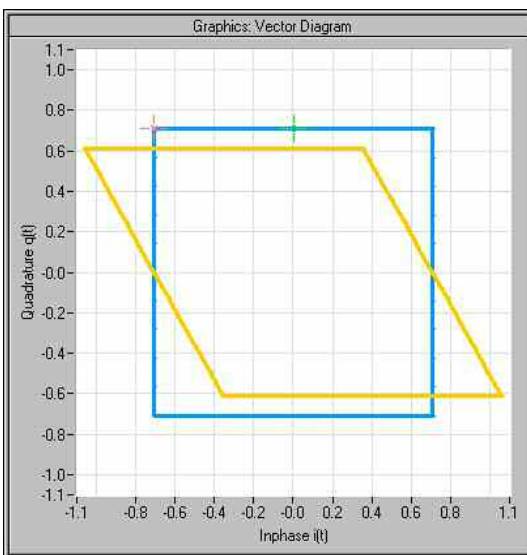

A negative quadrature offset means a phase angle less than 90 degrees:

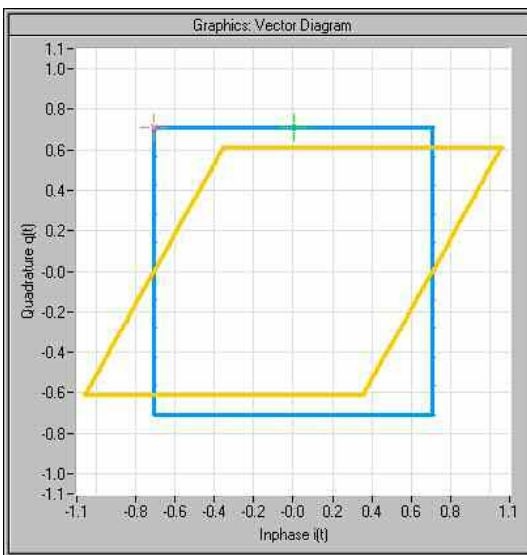

Remote-control command:  
 SOUR:BB:IMP:QUAD:ANGL 5DEG

**Optimize internal IQ-Impairments for RF Output - Digital Impairments**

Activates or deactivates internal compensation of signal distortions of the RF output. Signal distortions can be either optimized for the RF output (active) or for the differential I/Q output (not active).

Remote-control command:  
SOUR:BB:IMP:OPT:STAT ON

**Optimization Mode - Digital Impairments**

Selects the optimization mode.

**Fast**

Optimization is reached by compensation for I/Q skew.

Remote-control command:  
SOUR:BB:IMP:OPT:MODE FAST

**High Quality**

Optimization is reached by compensation for I/Q skew and frequency response correction.

Remote-control command:  
SOUR:BB:IMP:OPT:MODE QHIG

**Introduction - AWGN - Noise Generator**

The noise generator generates an AWGN signal (Additive White Gaussian Noise) in the digital baseband, i.e. the noise power density has a Gaussian distribution and is distributed evenly across the frequency. This noise signal superimposes the (interference-free) useful signal (**Additive Noise** mode). Typical applications for the noise generator are bit-error or block-error measurements, depending on the set C/N ratio.

The Gaussian noise is generated by means of feedback shift registers with subsequent probability transformation. The switching configuration is such that virtually ideal statistical characteristics are achieved:

- I and Q paths are decorrelated from each other.
- The crest factor of 18 dB allows very small probabilities to be realized.
- The period of the noise signal depends on the selected system bandwidth. The relationship of period P to system bandwidth B<sub>sys</sub> is approximated:

$$P \approx 1 \cdot 10^{13} / B_{\text{sys}}$$

This results in periods between 317 years with minimum bandwidth and approximately 2 days with maximum bandwidth.

This results in a period of approximately one month for 3GPP FDD with a bandwidth of 3.84 Mcps, and a period of 427 days for GSM with 270.833 kcps.

Scalable low-pass filters are used to produce a noise level with both a broad dynamic range and a broad bandwidth range (from 1 kHz to 60 MHz).

Apart from the **Additive Noise** mode, there are also the **Noise Only** and the **CW Interferer** mode. In the **Noise Only** mode a pure noise signal is generated and modulated to the carrier. In the **CW Interferer** mode, a sinusoidal signal with an adjustable frequency offset to the baseband signal is generated and added to the baseband signal by means of a counter instead of a shift register.

## AWGN Settings Menu

The **AWGN Settings** menu for setting the noise generator is opened either in the **AWGN / IMP** function block or in the menu tree of the **MENU** key under **AWGN Settings**.

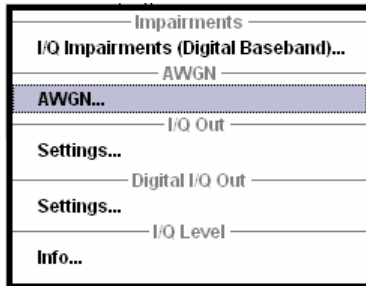

The **AWGN Settings** menu is divided into the following sections.

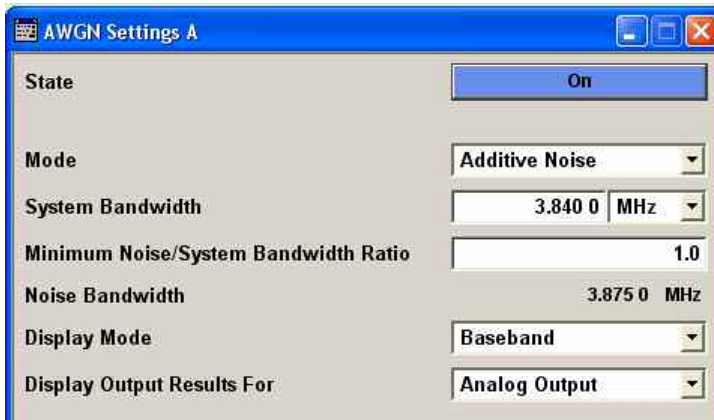

The RFI signal generator is activated, the mode selected and the interfering signal is configured in the top section of the menu.

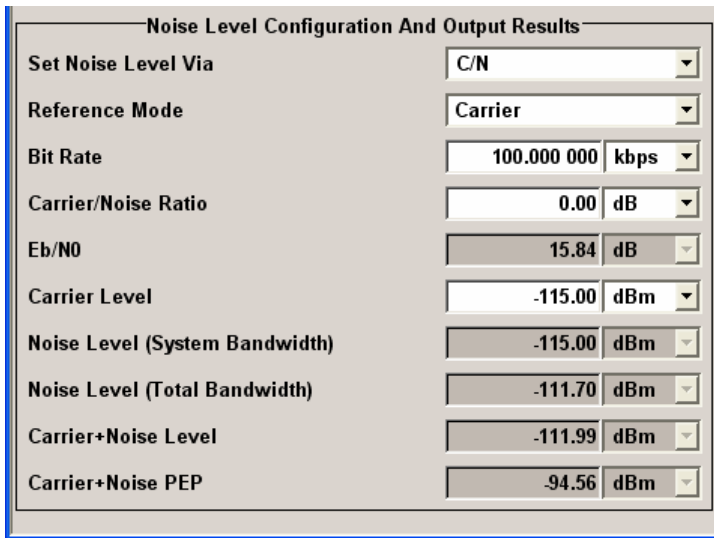

The level of the interfering signal is configured in the **Noise Level Configuration** section.

In **Additive Noise** and **CW interferer** mode, the interfering level can be defined and the resulting total level displayed here.

In **Noise Only** mode, only the noise level can be set here.

The RFI signal generator is activated, the mode selected and the interfering signal is configured in the top section of the menu.

**State - AWGN**

Activates/deactivates the RFI signal generator. The interferer (AWGN or CW interferer, depending on the selected mode) is generated as after the generator is activated.

Remote-control command:

SOUR:AWGN:STAT ON

**Mode - AWGN**

Selects the mode for generating the interfering signal.

**Additive Noise**

The AWGN noise signal with selectable system bandwidth is added to the baseband signal.

Remote-control command:

SOUR:AWGN:MODE ADD

**Noise Only**

The pure AWGN noise signal with selectable system bandwidth is modulated to the carrier. The connection to the baseband is interrupted.

Remote-control command:

SOUR:AWGN:MODE ONLY

**CW Interferer**

A sine with a defined frequency offset is added to the baseband signal. The calculation of  $E_b / N_0$  ratio is omitted.

Remote-control command:

SOUR:AWGN:MODE CW

**System Bandwidth - AWGN** (Additive Noise and Noise Only)

Sets the RF bandwidth to which the set carrier/noise ratio relates.

Within this frequency range, the signal is superimposed with a noise signal whose level corresponds exactly to the set C/N ratio.

**Note:**

*The noise signal is not generated arbitrarily for a particular bandwidth, but instead it is generated in steps. Noise therefore also occurs outside the set system bandwidth.*

Remote-control command:

SOUR:AWGN:BWID 1.23 MHz

**Minimum Noise/System Bandwidth Ratio - AWGN**

(Additive Noise and Noise Only)

Sets the ratio of minimum noise bandwidth to system bandwidth.

The noise signal is not generated arbitrarily for a particular bandwidth, but instead it is generated in steps. Noise therefore also occurs outside the set system bandwidth.

With this parameter the minimum real noise bandwidth can be set as required by some standards. It does not influence the calculation of level from the set C/N ratio in relation to system bandwidth.

The overall bandwidth "System BW x Minimum Noise/System BW Ratio" may not exceed 80 MHz.

Remote-control command:

SOUR:AWGN:BWID:RAT 2

**Noise Bandwidth - AWGN**

(Additive Noise and Noise Only)

Indicates the real noise bandwidth. The value is only indicated for **State On**.

**Note:**

*The noise signal is not generated arbitrarily for a particular bandwidth, but instead it is generated in steps. Noise therefore also occurs outside the set system bandwidth.*

Remote-control command:

SOUR:AWGN:BWID:NOIS?

**Display Mode - AWGN**

Sets the display mode to Baseband or RF.

Remote-control command:

SOUR:AWGN:DISP:MODE RF

**Display Output Results For - AWGN**

(Additive Noise and Noise Only, Display Mode Baseband only)

Selects the display of output results for the analog (DACIF) or the digital (BBOU) signal path.

**Note:**

*This selection field is only available with the option R&S SMx-B18, Baseband Digital I/Q Out. If the instrument is not equipped with this option the parameters of the analog signal path are displayed.*

**Analog Output**

The parameters of the analog signal path are displayed.

Remote-control command:

SOUR:AWGN:DISP:MODE BB

SOUR:AWGN:DISP:ORES ANAL

**Digital Output**

The parameters of the digital signal path are displayed.

Remote-control command:

SOUR:AWGN:DISP:ORES DIG



**Target CW Frequency - AWGN**

Sets the desired frequency of the sine in **CW Interferer** mode.

Remote-control command:

SOUR:AWGN:FREQ:TARG 3.4 MHz

**Resulting CW Frequency - AWGN**

Indication of the actual CW frequency of the sinusoidal signal in **CW Interferer** mode. The actual frequency may differ from the desired frequency, since the resolution is limited to 0.7 Hz.

**Note:**

*The desired frequency constellation can be precisely set with an accuracy of up to 0.01 Hz by selecting a suitable frequency offset of the baseband source (e.g. Custom Dig Mod) and by correcting the RF frequency by the difference between Resulting and Target CW Frequency.*

Remote-control command:

SOUR:AWGN:FREQ:RES?

The interfering signal is configured in the **Noise Level Configuration** section.

**Set Noise Level via - AWGN** (Additive Noise only)

Selects the mode for setting the noise level .

**C/N**

The noise level is set on the basis of the value entered for the carrier/noise ratio.

With digital modulation, the associated  $E_b/N_0$  value is determined and displayed

Remote-control command:

SOUR:AWGN:POW:MODE CN

 **$E_b/N_0$** 

The noise level is set on the basis of the value entered for the ratio of bit energy to noise power density.

The associated C/N value is displayed. The correlation between the two values is as follows:

$$\frac{C}{N} = \frac{E_b}{N_0} \frac{f_{bit}}{B_{sys}}$$

$f_{bit}$  = Bit rate (Symbol rate x Modulation value)

$B_{sys}$  = System bandwidth

With **Custom Dig Mod** signals, the bit rate used for calculation is defined by the selected standard in the **Custom Digital Mod** menu.

With **Digital Standard** signals, the bit rate to be used for calculating the  $E_b/N_0$  can be entered at **Bit Rate**.

Some test cases with the 3GPP base station tests (TS 25.141) specify, for example, E/N settings that apply to channel-coded data or block segments.

Remote-control command:

SOUR:AWGN:POW:MODE EN

**Reference Mode - AWGN**

(Additive Noise and CW Interferer)

Select reference mode if the C/N or  $E_b/N_0$  ratio is changed.**Carrier**

If the C/N value or  $E_b/N_0$  value changes, the carrier level is kept constant and the noise level is adjusted. This is the standard procedure for measuring the bit error rate versus the noise power.

Remote-control command:

SOUR:AWGN:POW:RMOD CARR

**Noise**

If the C/N value or  $E_b/N_0$  value changes, the noise level is kept constant and the carrier level is adjusted.

Some test cases of 3GPP Base Station Tests (TS 25.141) specify, for example, that the noise power be permanently set as a function of the base station power class, whereas the carrier power is variable.

Remote-control command:

SOUR:AWGN:POW:RMOD NOIS

**Bit Rate - AWGN**

(Additive Noise only)

Sets or indicates the bit rate used for converting C/N to  $E_b/N_0$ .**Custom Digital Mod:**

With **Custom Digital Mod** signals, the bit rate used is indicated here. It is defined by the choice of the standard in the **Custom Digital Mod** menu.

**Digital Standard:**

With **Digital Standard** signals, the bit rate used for converting C/N to  $E_b/N_0$  is set here.

When generating a **Digital Standard**, it is thus possible to select which bit rate is to be used for calculating the ratio of bit energy to noise power density, e.g. the bit rate before or after channel coding.

Remote-control command:

SOUR:AWGN:BRAT 3.4E6

**Carrier Noise Ratio - AWGN** (Additive Noise and CW Interferer only)

Sets the carrier/noise ratio.

**Reference Mode Carrier**

This entry determines the RFI power in the **Reference Mode Carrier** and thus the power of the output signal. It does not affect the power of the useful signal, i.e. the carrier power remains constant.

**Reference Mode Noise**

This entry determines the power of the useful signal in the **Reference Mode Noise**, i.e. the carrier power. The RFI power remains constant.

The level of the noise signal which is derived from the entered C/N value is displayed in the menu under **Noise Level**. The value is displayed automatically in the units of the useful signal.

The level of the useful signal is displayed in the menu under **Carrier Level** and can also be changed there. The displayed value corresponds to the value in the **Level** display field.

The level of the output signal is displayed under **Carrier Level + Noise**.

If **Set Noise Level via Eb/N0** is selected, the associated C/N value is displayed here.

Remote-control command:

SOUR:AWGN:CNR 10 dB

**Eb N0 - AWGN**

(Additive Noise only)

Sets the ratio of bit energy to noise power density in **Additive Noise** mode.

**Reference Mode Carrier**

This entry determines for **Reference Mode Carrier** the noise level and therefore also the level of the output signal. It does not affect the level of the useful signal, i.e. the carrier level is kept constant.

**Reference Mode Noise**

This entry determines for **Reference Mode Noise** the level of the useful signal, i.e. the carrier level. the noise level is kept constant.

The level of the noise signal which is derived from the entered Eb/N0 value is displayed under **Noise Level**. The value is displayed automatically in the units of the useful signal.

The level of the useful signal is displayed in the menu under **Carrier Level**. The displayed value corresponds to the value in the **Level** display field.

The level of the output signal is displayed under **Carrier Level + Noise**.

If **Set Noise Level via C/N** is selected, the associated Eb/N<sub>0</sub> value is displayed here.

Remote-control command:

SOUR:AWGN:ENR 10 dB

**Carrier Level - AWGN**

(Additive Noise and CW Interferer)

**Reference Mode Carrier**

Sets the carrier level for **Reference Mode Carrier**. This entry corresponds to the level entered in the **Level** header.

The level of the noise signal which is derived from the entered C/N value is displayed under **Noise Level**. The value is displayed automatically in the units of the useful signal.

**Reference Mode Noise**

Indicates the carrier level which is derived from the entered C/N value for **Reference Mode Noise**. This indication corresponds to the level indicated in the **Level** header.

The noise level can be set under **Noise Level**.

**Note:**

*The peak envelope power (PEP) specified in the header corresponds to the PEP value of the carrier. The PEP value of the overall signal is displayed in the menu under **Carrier +Noise PEP**.*

Remote-control command:

SOUR:AWGN:POW:CARR 10 dBm

**Noise Level (System Bandwidth) - AWGN****Noise Only mode:**

Sets the level of the noise signal.

In this mode, this entry corresponds to the level entered in the **Level** header.

**Additive Noise mode:****Reference Mode Noise**

Sets the level of the noise signal. The level of the carrier is derived from the entered C/N or  $E_b/N_0$  value.

**Reference Mode Carrier**

Displays the level of the noise signal in the system bandwidth. The level of the noise signal is derived from the entered C/N or  $E_b/N_0$  value. The carrier level is entered under **Carrier Level**.

**Note:**

*The noise signal is not generated arbitrarily for a particular bandwidth, but instead it is generated in steps. Noise therefore also occurs outside the set system bandwidth. This means that the total measurable noise level (see below) usually exceeds the value displayed here. Correct measurement of the noise level within the system bandwidth is possible by means of channel power measurement using a signal analyzer.*

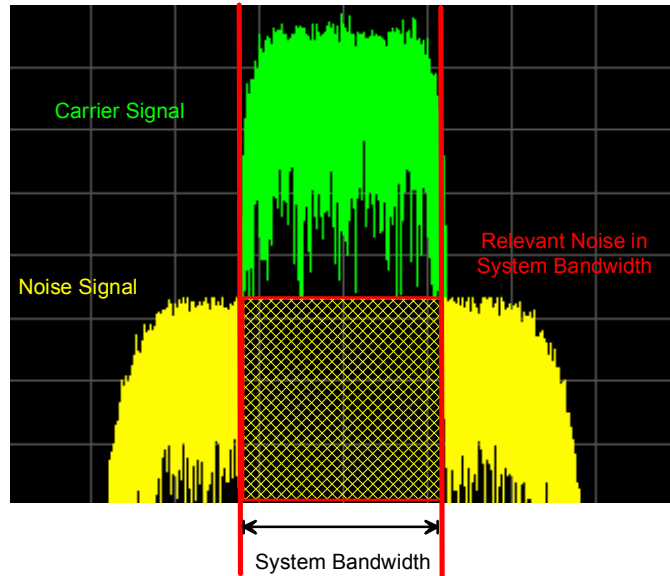

**Additive CW Interferer mode:**

**Reference Mode Noise**

Sets the level of the interfering signal. The level of the carrier is derived from the entered C/N value.

**Reference Mode Carrier**

Displays the level of the interfering signal. The level of the interfering signal is derived from the entered C/N value. The carrier level is entered under **Carrier Level**.

**Remote-control command:**

SOUR:AWGN:POW:NOIS 10 dBm

**Noise Level (Total Bandwidth) - AWGN**

Displays the level of the noise signal in the total bandwidth in **Noise Only** and **Additive Noise** mode:

**Note:**

*The noise signal is not generated arbitrarily for a particular bandwidth, but instead it is generated in steps. Noise therefore also occurs outside the set system bandwidth. This means that the total measurable noise level usually exceeds the value of the noise level in the system bandwidth. Correct measurement of the noise level within the system bandwidth is possible by means of channel power measurement using a signal analyzer.*

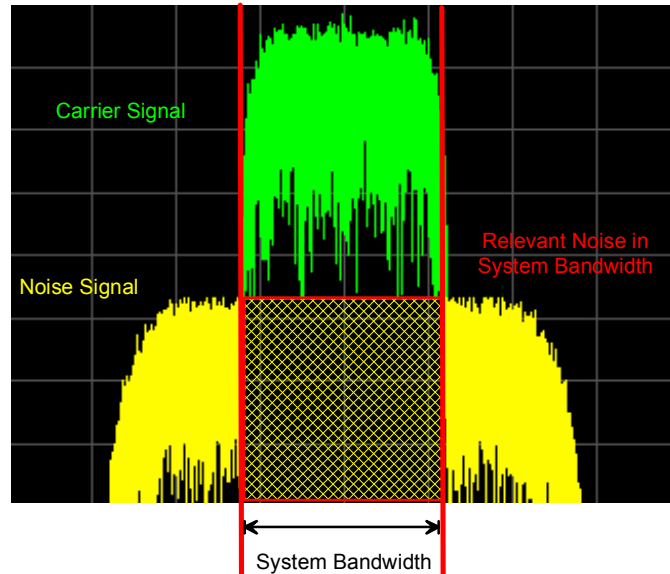

Remote-control command:

SOUR:AWGN:POW:NOIS:TOT?

Response: 19 dB

**Carrier + Noise Level - AWGN**

(Additive Noise and CW Interferer)

Displays the overall level of the noise signal plus useful signal.

Remote-control command:

SOUR:AWGN:POW:SUM?

**Carrier + Noise PEP - AWGN**

(Additive Noise and CW Interferer)

Displays the peak envelope power of the overall signal comprised of noise signal plus useful signal.

**Note:**

*The peak envelope power (PEP) specified in the header corresponds to the PEP value of the carrier.*

Remote-control command:

SOUR:AWGN:POW:SUM:PEP?

## Output of the Baseband Signal - I/Q Out

The R&S Signal Generator provides various outputs of the baseband signal. The digitally modulated signal can either be output directly or converted to an analog I/Q baseband output signal.

The **analog baseband signal** can be output single-ended or differential (non-inverted) at the I/Q output connectors **I OUT / I OUT BAR** and **Q OUT / Q OUT BAR** on the rear panel of the instrument (Option R&S SMJ-B16, Differential Output).

The output of the **digital baseband signal** requires the option R&S SMJ-B18, Digital I/Q Out. The signal is output at the standardized (LVDS) digital I/Q interface on the rear panel. Digital signal output is possible for path A only.

### Note:

To avoid electromagnetic interference (EMI) only the cable R&S SMx-Z6 must be used for the connection to the digital interface BBOU.



The settings dialogs for the analog and digital signal output are available in the block diagram in the "**AWGN / IMP**" function block as well as in the menu with the same name which is opened using the **[MENU]** key.

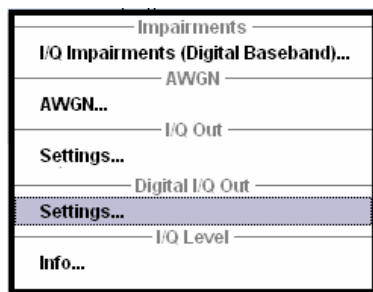
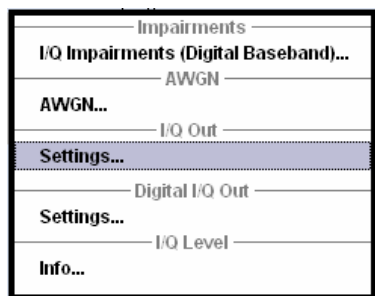

The parameters of the **analog signal** output are configured in the **Analog I/Q Output Settings** dialog (path A and path B). The settings for the **digital signal** output are available in the **Digital I/Q Output Settings** dialog (path A only).

The R&S Signal Generator provides various outputs of the baseband signal. Converted to an analog I/Q baseband signal the digitally modulated signal can be output single-ended or differential (non-inverted).

The settings dialogs for the analog and digital outputs are available in the block diagram in the "**AWGN / IMP**" function block as well as in the menu with the same name which is opened using the **[MENU]** key.

The single ended or differential output (option R&S SMJ-B16, Differential Output) is configured in the **Analog I/Q Output Settings** dialog.

The differential output of the R&S Vector Signal Generator provides symmetrical signals for differential inputs of DUTs without the need of additional external electric network. The operating point of the inputs can be set by a definable DC-voltage (bias). In addition an offset between inverting and non-inverting output can be set to balance a difference of the best operating points.

The equipment options for the basic unit (R&S SMJ with frequency option R&S SMJ-B10x) include the option R&S SMJ-B13 (Baseband Main Module) and the option R&S SMJ-B16 (Differential Output) for I/Q Out...

**Note:**

*Option R&S SMJ-B16 (Differential Outputs) cannot be fitted together with options R&S SMJ-B81 (Rear Panel Connectors), because they use the same connectors.*

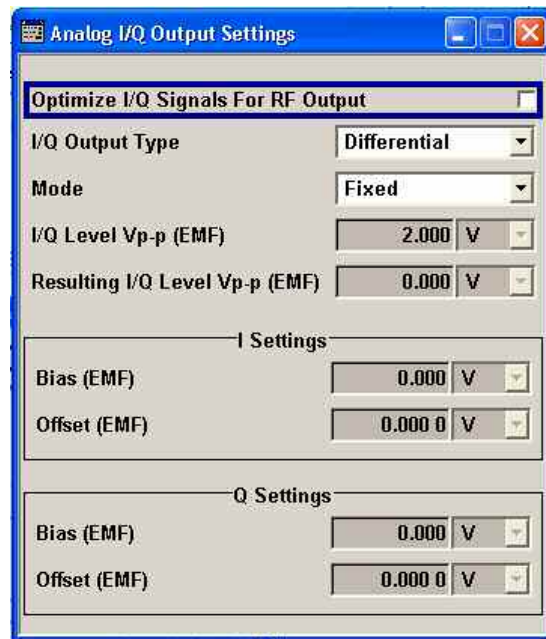
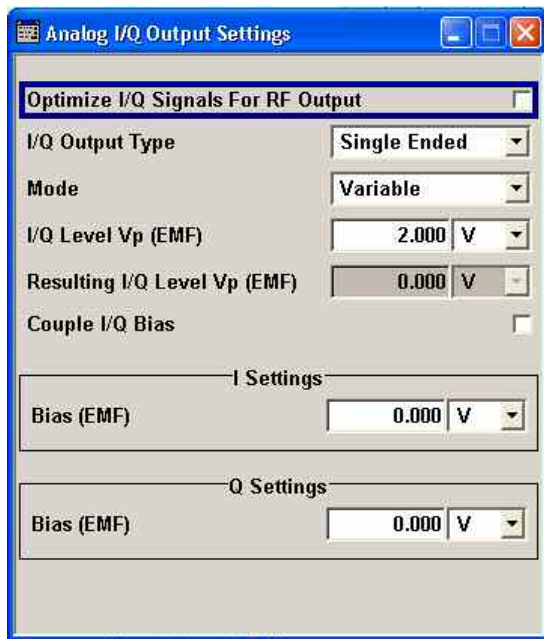

**Optimize IQ-Signals for RF Output - Differential Outputs - IMP Block**

Activates/deactivates optimization of level accuracy and imbalance for RF Output.

Level accuracy and imbalance can be either optimized for RF output (active) or for differential outputs (not active).

Remote-control command:

SOUR:IQ:OUTP:BIAS:OPT:STAT ON

**Output Type - Differential Outputs - IMP Block**

Selects the type of output. The menu changes depending on the selection



**Differential**

Differential output at **I OUT** and **I OUT BAR / Q OUT** and **Q OUT BAR**. The analog I/Q signal components are output at I/Q OUT and I/Q OUT BAR. A bias to set the operating point of DUT can be defined. In addition an offset between inverting and non-inverting output can be set to balance a difference of the best operating points.

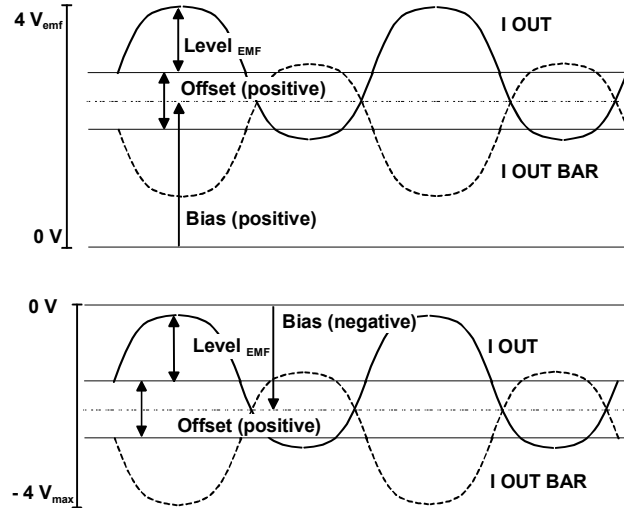

Remote-control command:  
`SOUR:IQ:OUTP:TYPE DIFF`

**Single Ended**

Single-ended output at **I OUT** and **Q OUT**. A bias between I/Q OUT and ground can be defined.

Remote-control command:  
`SOUR:IQ:OUTP:TYPE SING`

**Output Mode - Differential Outputs - IMP Block**

Selects the mode for setting the outputs - independent or together. The menu changes depending on the selection here.

**Fixed**

The settings for the I/Q signal components are fixed and cannot be changed.

**Level Vp-p (EMF) (Single ended) = 1.0 V**

**Level Vp-p (EMF) (Differential) = 2.0 V**

**Bias = 0 V**

**Offset = 0 V**

Remote-control command:  
`SOUR:IQ:OUTP:MODE FIX`

**Variable**

The settings for the I/Q signal components are not fixed and can be modified.

Remote-control command:  
`SOUR:IQ:OUTP:MODE VAR`

**I/Q Level EMF - Differential Outputs - IMP Block** Sets the output voltage for both signal components. Small differences at the inputs can be taken into account via impairment settings (see following section "[Impairment Settings Menu](#)").

**Single ended Output:**

Value range: 20 mV ... 2 V EMF.

The maximum overall output voltage is:

$$(\text{Level EMF} + |\text{Bias}|) \leq 3.7 \text{ V}$$

**Differential Output:**

Value range: 40 mV ... 4 V EMF.

The maximum overall output voltage is:

$$(\text{Level EMF} + |\text{Bias}| + \text{Offset}) \leq 3.7 \text{ V}$$

Remote-control commands:

```
SOUR:IQ:OUTP:LEV 0.1
```

**Resulting I/Q Level EMF - Differential Outputs - IMP Block** Displays the resulting output off-load voltage of both signal components at the rear panel.

Remote-control command:

```
SOUR:IQ:OUT:LEV:RES?
```

**Couple IQ Bias - Differential Outputs - IMP Block**

**Variable output mode only**

Activates/deactivates coupling of bias setting of the I-signal and Q-signal component. For activated coupling, the setting can be made for the I-signal component, it automatically applies to the Q-signal component as well. The fields for setting the Q-signal component are shaded.

Remote-control command:

```
SOUR:IQ:OUTP:BIAS:COUP:STAT ON
```

In menu area **I Settings** and **Q Settings** the bias and offset settings are made.

**Bias - Differential Outputs - IMP Block** (EMF) Sets the bias. A DC voltage is superimposed upon the I or Q signal. The maximum overall voltage (Level EMF + Bias + Offset) is 3.7 volts.

This way, the operating point of a DUT can be set.

Remote-control commands:

```
SOUR:IQ:OUTP:BIAS:I -0.5V
```

```
SOUR:IQ:OUTP:BIAS:Q 0.5V
```

**Offset - Differential Outputs - IMP Block** Sets an offset between the inverting and the non-inverting output. The maximum overall voltage (**Level EMF + Bias + Offset**) is 3.7 Volt. The set value is set half in the positive and half in the negative direction:

A positive offset is set with half of the value in positive direction at the non-inverting outputs, in negative direction at the inverting outputs, respectively.

For example, if a 100.0 mV offset value is set for the I signal component, the output signal at **I OUT** will have a 50.0 mV offset and the output signal at **I OUT Bar** will have a - 50.0 mV offset.

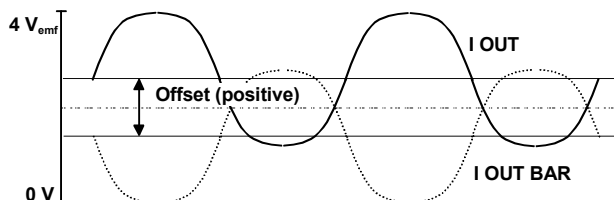

A negative offset is set with half of the value in negative direction at the non-inverting outputs, in positive direction at the inverting outputs, respectively.

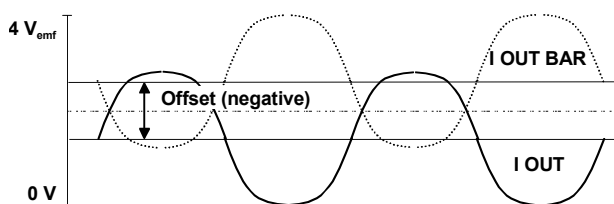

This setting is available only for output type **Differential**.

Remote-control commands:

```
SOUR:IQ:OUTP:OFFS:I 0.01V
```

```
SOUR:IQ:OUTP:OFFS:Q 0V
```

## Digital I/Q Output

The menu item **Settings** in the **Digital I/Q Out** section opens the dialog to select the clock source and set the signal output level. The output of the digital baseband signal is only available with the option R&S SMJ-B18, Digital I/Q Out.

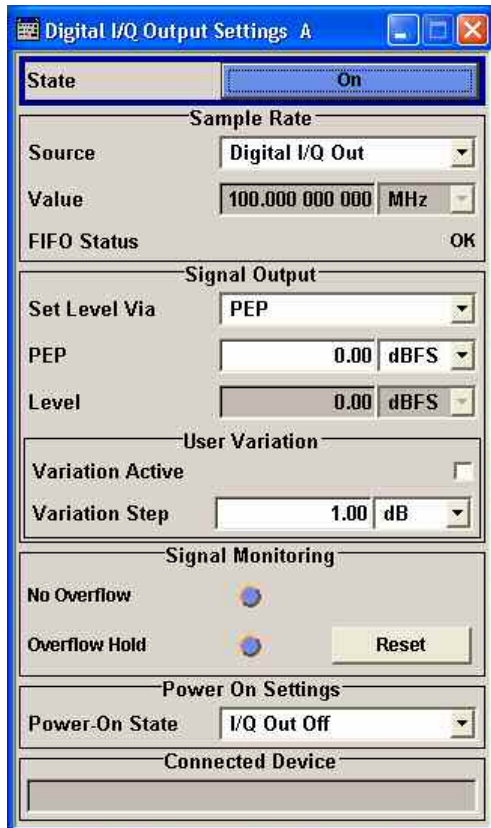

**State - Digital I/Q Output** Switches On/Off the digital I/Q output signals.

**On** Switches on the digital I/Q output signal.

Remote-control command:  
SOUR:IQ:OUTP:DIG:STAT ON

**Off** Switches off the I/Q output signal.

Remote-control command:  
SOUR:IQ:OUTP:DIG:STAT OFF

### EX-I/Q-Box Settings... - Digital I/Q Output

**With a connected R&S EX-IQ-Box only.**

Opens the main settings dialog of the R&S EX-IQ-Box.

Remote-control command: n.a.

In the **Sample Rate** section the sample rate for the digital I/Q output signal can be set and the state of signal transmission is indicated by the FIFO Status.

Sample Rate	
Source	User Defined
Value	100.000 000 000 MHz
FIFO Status	OK

### Sample Rate Source - Digital I/Q Output

Selects the source for the sample rate of the digital I/Q output signal.

#### Note:

*With a connected R&S EX-IQ-Box either the internal clock source (User defined) or an external clock (Digital I/Q In) can be selected in the settings dialog of the R&S EX-IQ-Box. Therefore, the sample rate source is only indicated in this field.*

#### User Defined

The internally generated clock reference signal is used. The sample rate is calculated and displayed in the field **Value**.

Remote-control command:

SOUR:IQ:OUTP:SRAT:SOUR USER

#### Digital I/Q Out

An external clock reference signal is used. The clock signal is directly fed in via pin **CLK2** of the digital output interface (option R&S SMJ-B18, Digital I/Q Out). The sample rate is displayed in the field **Value**.

Remote-control command:

SOUR:IQ:OUTP:SRAT:SOUR DOUT

### Sample Rate Value - Digital I/Q Output

Sets or displays the sample rate of the digital I/Q output signal, depending on the selected Sample Rate Source.

Remote-control command:

SOUR:IQ:OUTP:DIG:SRAT 100 MHZ

### FIFO Status - Digital I/Q Output

Indicates the state of the signal transmission.

#### OK

Resampling is working properly.

#### OFL = Overflow

The external sample rate frequency is too high which causes an overflow in signal transmission.

#### URUN = Underrun

The external sample rate is too low which causes an underrun in signal transmission.

Remote-control command:

SOUR:IQ:OUTP:DIG:SRAT:FIFO:STAT?

The level of the output signal is set in the **Signal Output** section. For entering the value, level type **PEP** or **Level** can be chosen.

Signal Output		
Set Level Via	PEP	
PEP	0.00	dBFS
Level	-4.67	dBFS

### Set Level Via - Digital I/Q Out

Selects the level type (PEP/Level) that is used to set the signal level of the currently selected path. Either the PEP or the Level entry field can be edited.

#### PEP

The signal level is expressed in terms of a peak envelope power value (PEP).

The level entry fields and the corresponding units are displayed in the status bar.

Remote-control command:

```
SOUR:IQ:OUTP:POW:VIA PEP
```

#### Level

The signal level is expressed in terms of a rms value.

The level entry fields and the corresponding units are displayed in the status bar.

Remote-control command:

```
SOUR:IQ:OUTP:POW:VIA LEV
```

### PEP - Digital I/Q Out

The signal level is expressed in terms of a peak envelope power value (PEP).

The level entry fields and the corresponding units are displayed in the status bar. The level display always refers to both signal components ( $\sqrt{I^2+Q^2}$ ).

Remote-control command:

```
SOUR:IQ:OUTP:DIG:POW:PEP -10 DBFS
```

### Level - Digital I/Q Out

The signal level is expressed in terms of a rms level value.

The level entry fields and the corresponding unit are displayed in the status bar. The level display always refers to both signal components ( $\sqrt{I^2+Q^2}$ ).

Remote-control command:

```
SOUR:IQ:OUTP:DIG:POW:LEV -10 DBFS
```

If the level is set using the rotary knob, the step width is defined in the **User Variation** section.

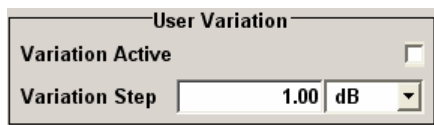

**Variation Active - Digital I/Q Out** Activates the user-defined step width that is used by varying the level value with the rotary knob.

**On** The level value set with the rotary knob is varied using the user-defined step width which is entered under **Variation Step**.

Remote-control command:  
`SOUR:IQ:OUTP:DIG:POW:STEP:MODE USER`

**Off** The level value set with the rotary knob is varied in steps of one unit at the cursor position (standard operating mode).

Remote-control command:  
`SOUR:IQ:OUTP:DIG:POW:STEP:MODE DEC`

**Variation Step - Digital I/Q Out** Sets the user defined step width for entering the level value using the rotary knob. Level variation with this step width must be activated with **Variation Active ON**.

Remote-control command:  
`SOUR:IQ:OUTP:DIG:POW:STEP:INCR 2 dB`

The section **Signal Monitoring** indicates digital signal clipping.



**Overflow - Digital I/Q Out** Indicates that the I/Q output signal is currently clipped. This indication also appears in the block diagram close to the digital I/Q Out connector.

Overflow may occur, e.g. if the level of the output signal, or the noise level (AWGN) are too high.

Remote-control command:  
`SOUR:IQ:OUTP:DIG:OFL:STAT?`

**Overflow Hold - Digital I/Q Out** Indicates an overflow since last reset.  
The overflow hold state can be reset via the **Reset** button next to the LED, or is reset automatically by starting a new signal generation or by setting new values to the output level.

Remote-control command:  
SOUR:IQ:OUTP:DIG:OFL:HOLD:STAT?

**Reset - Digital I/Q Out** Executes a reset of the overflow hold state and LED.

Remote-control command:  
SOUR:IQ:OUTP:DIG:OFL:HOLD:RES

The power on behaviour of the R&S SMJ is set in the **Power On Settings** section.

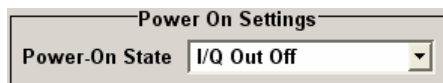

**Power-On State - Digital I/Q Out** Selects the state which the digital I/Q Output is to resume after the instrument is switched on.

**I/Q Out Off** The output is deactivated when the instrument is switched on.

Remote-control command:  
SOUR:IQ:OUTP:DIG:PON OFF

**Previous Setting** When the instrument is switched on the digital I/Q output resumes to the status that was active before the last switch off.

Remote-control command:  
SOUR:IQ:OUTP:DIG:PON UNCH

**Connected Device - Digital I/Q Out** Indicates the ID of an externally connected R&S Instrument or R&S Device.

Remote-control command:  
SOUR:IQ:OUTP:DIG:CDEV?



# I/Q Level - Info...

## Baseband Signal Level

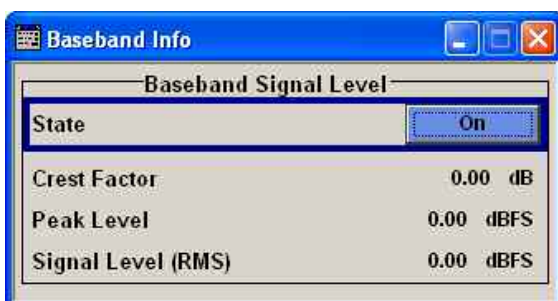
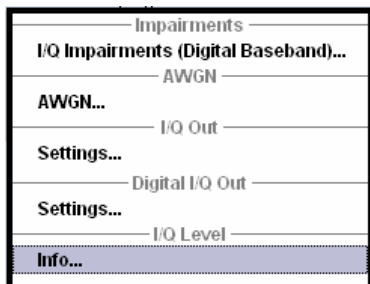

The signal levels and the crest factor of the baseband signal at the I/Q output connectors are indicated in the dialog box **Baseband Signal Level**.

**Note:**

*Up to baseboard version DacBoard 1141.8090.xx the calculated signal levels are displayed. From "DacBoard 1141.8190.02" or higher monitoring the measurement with or without interfering is provided.*

This information is needed by the user, for example, in order to use the I/Q signal externally and to adjust the level correctly there, or to see how the signal is modulated.

**Crest Factor - Digital Impairments**

Indicates the crest factor of the baseband signal.

The crest factor is calculated from the two level parameters as follows:

$$Crest[dB] = \frac{Peak\_Level[dBFs]}{Signal\_Level[dBFs]}$$

Remote-control command:

SOUR:BB:CFAC?

**Peak Level - Digital Impairments**

Indicates the peak level of the baseband signal relative to full scale of 0.5 V (in terms of dB full scale).

Remote-control command:

SOUR:BB:POW:PEAK?

**Signal Level (RMS)- Digital Impairments**

Indicates the rms level of the baseband signal relative to full scale of 0.5 V (in terms of dB full scale).

Remote-control command:

SOUR:BB:POW:RMS?

## Baseband Signal Level Measurement

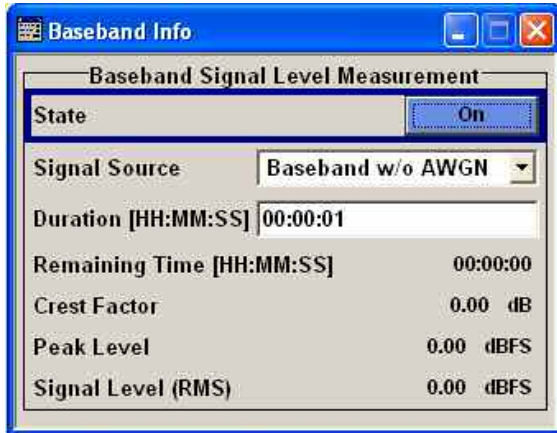

Information on the baseband I/Q signal during measurement is indicated in the dialog box **Baseband Signal Level Measurement**. Level, crest factor and duration of the measurement can be displayed for a I/Q signal either with or without interfering (AWGN).

### Note:

*Monitoring the measurement of the digital I/Q baseband signal requires the baseboard version "DacBoard 1141.8190.02" or higher. Up to baseboard version DacBoard 1141.8090.xx only the calculated signal levels are provided. The currently equipped DacBoard is listed in the dialog **Setup System Hardware Config**, section **Baseband Assembly**.*

**State - Digital Impairments - Measurement** - Activates/deactivates the measurement of the digital I/Q baseband signal.

When activated, information on the peak level, rms level and crest factor are indicated. Additionally the duration of the measurement can be set.

Remote-control command:  
SOUR:BB:MEAS:STAT ON

**Signal Source - Digital Impairments - Measurement**

Selects the signal for the measurement. The signal level and crest factor can be retrieved either from the interference-free digital I/Q baseband signal or the signal superimposed by the noise generator AWGN.

**Baseband w/o AWGN**

Activates the measurement of the interference-free baseband signal.

Remote-control command:  
SOUR:BB:MEAS:SOUR BB

**Baseband with AWGN**

Activates the measurement of the baseband signal after an AWGN noise signal is added.

Remote-control command:  
SOUR:BB:MEAS:SOUR BAWG

**Duration - Digital Impairments - Measurement**

Enters the time for the measurement of the digital I/Q baseband signal in the range of 1 s ... 3 h. The time is to be entered in format "hh:mm:ss".

Remote-control command:  
SOUR:BB:MEAS:DUR "00:15:30"

<b>Remaining Time - Digital Impairments - Measurement</b>	<p>Indicates the remaining time until the measurement of the digital I/Q baseband signal is completed. The time is displayed in format "hh:mm:ss".</p> <p>Remote-control command: SOUR:BB:MEAS:RTIM?</p> <p>Response: "00:15:30"</p>
<b>Crest Factor - Digital Impairments - Measurement</b>	<p>Indicates the crest factor of the baseband signal during measurement.</p> <p>Remote-control command: SOUR:BB:MEAS:CFAC?</p>
<b>Peak Level - Digital Impairments - Measurement</b>	<p>Indicates the peak level of the baseband signal relative to full scale of 0.5 V (in terms of dB full scale) during measurement.</p> <p>Remote-control command: SOUR:BB:MEAS:POW:PEAK?</p>
<b>Signal Level (RMS)- Digital Impairments - Measurement</b>	<p>Indicates the rms level of the baseband signal relative to full scale of 0.5 V (in terms of dB full scale) during measurement.</p> <p>Remote-control command: SOUR:BB:MEAS:POW:RMS?</p>



# Baseband Signal - Baseband

## Introduction - Baseband Signal

The R&S Signal Generator provides you with the ability to generate digital modulation signals in accordance with the definitions in the digital standards or with user-definable characteristics. Signals are generated in realtime or from a data store with the aid of external and internal data. You can also load externally computed modulation signals into the R&S Signal Generator in the form of waveform files.

Several digital standards are provided, plus digital modulation with user-definable signal characteristics, generation of waveforms with the aid of the Arbitrary Waveform Generator and generation of multi carrier CW signals with the aid of Multi Carrier CW.

The settings for digital modulation can be accessed in the block diagram via the "**Baseband**" function block or with the aid of the **[MENU]** key.

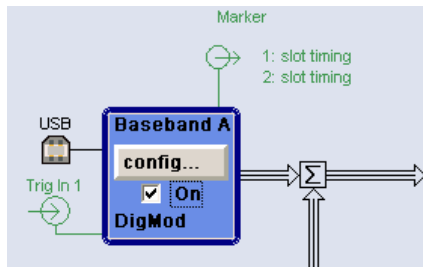

The equipment layout for generating the internal, digital modulation signals includes the options Baseband Main Module (B13) and one of the options Baseband Generator (B9/B10/B11). The three Baseband Generator options feature different ARB memory sizes (see data sheet). Apart from the memory size, however, the options offer the same functionality, either one can be installed.

In addition, the appropriate option is required for the digital standards. These options are specified in the description of the respective standard.

In the subsequent signal route the baseband signals can be frequency-shifted, detuned or loaded with noise (see sections "Menu Impairment Settings" and "Noise generator - AWGN").

## Signal Routing and Frequency Shifting

In the case of two-path instruments, signal routing, frequency offset and path gain definition are defined at the topmost menu level in the **Baseband** block or by using the **MENU** button under **Baseband**.

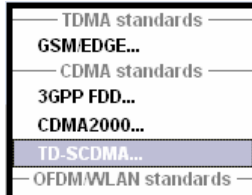

The upper part of the **Baseband** menu is used for selecting digital standards, digital modulation and waveform generation. These menus are described in the respective chapters relating to the modulation systems.

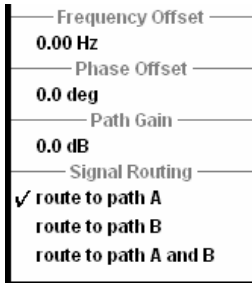

The lower part of the **Baseband** menu can be used to define a frequency offset, a path gain, a phase offset, and the signal routing for two-path instruments.

The **Frequency Offset** section is used to enter the frequency offset.

### Frequency Offset - Baseband

Enters the frequency offset for the baseband signal.

The offset affects the signal on the **Baseband block** output. It shifts the useful baseband signal in the center frequency.

#### Note:

*For sample rates of exactly 100 MHz (Mode **Digital Input (Native 100 MHz)**) it is not possible to enter a frequency offset. The digital signal is fed into the signal path directly and not routed to the resampler where the frequency offset takes place. This type of entry is also prohibited if the noise generator (AWGN block) is on.*

The complex I/Q bandwidth of the shifted useful signal must not exceed 80 MHz in total. The following applies:

$$f_{\text{offset}} - \frac{f_{\text{use}}}{2} \geq -80/2 \text{ MHz} \quad \text{and} \quad f_{\text{offset}} + \frac{f_{\text{use}}}{2} \leq +80/2 \text{ MHz}$$

$f_{\text{use}}$  = the complex useful bandwidth of the I/Q signal before the offset.

$f_{\text{offset}}$  = frequency offset.

The following graph illustrates the setting range for the frequency offset.

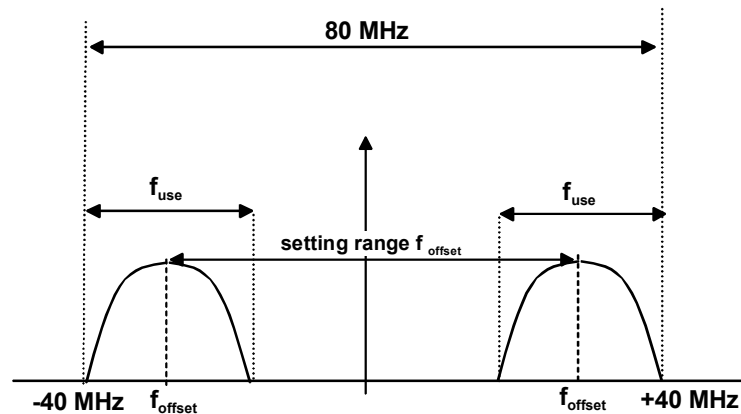

### Example:

3GPP FDD signal (chip rate 3.84 Mcps, root-cosine filter 0.22).

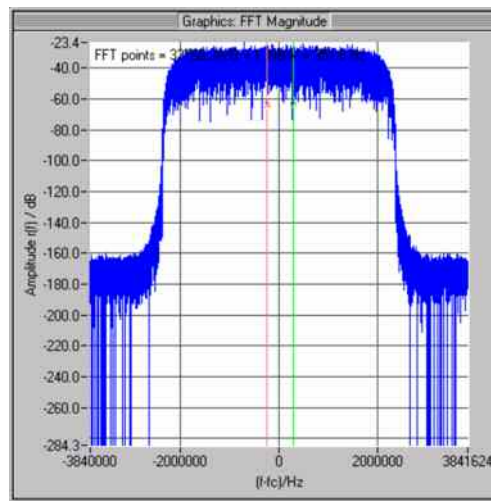

The complex useful bandwidth of a signal which has been filtered using a root-cosine filter with roll off  $\alpha$  is calculated as follows:

$$f_{use} = (1 + \alpha) * f_{symbol}$$

$f_{symbol}$  = the symbol rate or chip rate of the signal.

In the example the complex useful bandwidth is calculated as follows:

$$F_{use} = (1 + 0.22) * 3.84 \text{ MHz} = 4.6848 \text{ MHz.}$$

So as to comply with the condition requiring a maximum I/Q bandwidth of 40 MHz, the valid range of values for the frequency offset is then:

$$-40\text{MHz} + \frac{4.6848 \text{ MHz}}{2} \leq f_{offset} \leq 40\text{MHz} - \frac{4.6848 \text{ MHz}}{2} =$$

$$-35.3152\text{MHz} \leq f_{offset} \leq 35.3152\text{MHz}$$

In the case of ARB signals, the output clock rate can be used for estimating the maximum I/Q bandwidth of the waveform.

Remote-control command:

SOUR:BB:FOFF 2MHZ

The **Path Gain** section is used to enter the relative path gain.

#### Path Gain - Baseband

Enters the path gain for the baseband signal of the selected path compared to the baseband signal of the other path and/or of the external baseband input.

The gain affects the signal on the **Baseband block** output.

The **Path Gains** of the different baseband sources (Baseband A and Baseband B) define the relative gain of the associated signals. The real gain depends on the following parameters along with the set path gain:

- Signal characteristics, in particular the crest factor
- Number of baseband sources

The sum baseband signal can be verified in the spectrum display in the **Graphics** block.

Remote-control command:

SOUR:BB:PGA 2 dB

The **Signal Routing** section is used to define the signal route for two-path instruments.

#### Signal Routing - Baseband

Selects the signal route for the baseband signal of a two-path instrument. The following table shows the combination of signal routes allowed for two-path instruments.

**Route to path A** The baseband signal is introduced into path A. The signals from both paths are summed if necessary.

Remote-control command:

SOUR:BB:ROUT A

**Route to path B** The baseband signal is introduced into path B. The signals from both paths are summed if necessary.

Remote-control commands:

SOUR:BB:ROUT B

**Route to path A and B** The baseband signal is introduced into path A and path B. The signals from both paths are summed if necessary.

Remote-control command:

SOUR:BB:ROUT AB



## Data and Signal Sources in Baseband

This section describes the common characteristics of the signals used for generating the baseband signal for all standards, including for example all listed data sources. The selection in the digital menus at any given time depends on the parameter and standard concerned and is clear from the selection list offered in the menu. The external data sources may therefore not be available in certain cases.

Characteristics which are uniquely specific to particular standards are described in relation to the menu concerned.

The following input signals are used when digital modulation signals are being generated:

- Modulation data
- Clock signals
- Control signals

The input signals can be both internally generated and supplied from an external source. The internally generated data and clock signals are output not only on the DATA and Clock connectors but also on the corresponding pins of the AUX I/O interface.

Likewise control signals and also trigger signals for triggering signal generation in the R&S Signal Generator can be internally generated or supplied from an external source.

Up to four marker output signals for synchronizing external instruments can be user-defined.

Externally computed waveform files can be loaded via one of the computer interfaces (USB - memory stick, or Ethernet interface - network drive) or via the IEC bus in the instrument and generated with the aid of the Arbitrary Waveform Generator (ARB, see section "[Arbitrary Waveform Generator ARB](#)", page 4.235). Internally the **Multi Carrier CW** menu for defining multi carrier waveforms is available (see "[Multi Carrier Continuous Wave](#)").

### Internal PRBS Data and Data Patterns

PRBS generators deliver pseudo-random binary sequences of differing length and duration. They are known as maximum length sequences, and are generated with the aid of ring shift registers with feedback points determined by the polynomial.

By way of example, the diagram below shows a 9-bit generator with feedback to registers 4 and 0 (output).

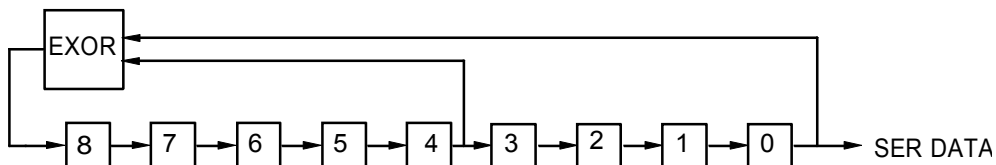
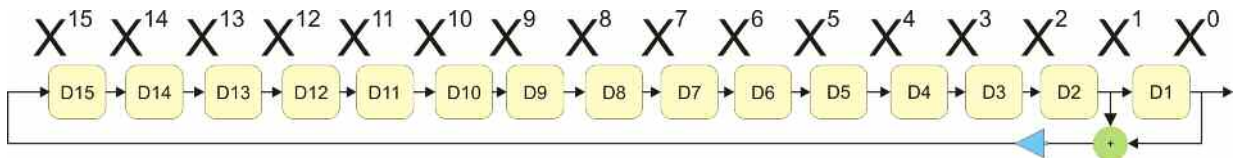

Fig. 4-1 9-bit PRBS generator

**Note:**

*For PRBS15 and PRBS23, a CCITT V.52-compliant data inversion is performed in the feedback path automatically as shown below:*



The pseudo-random sequence from a PRBS generator is uniquely defined by the register number and the feedback. The following table describes all the available PRBS generators:

Table 4-1 PRBS generators

PRBS generator	Length in bits	Feedback to	Menu selection
9-bit	$2^9 - 1 = 511$	Registers 4, 0	PRBS 9
11-bit	$2^{11} - 1 = 2047$	Registers 2, 0	PRBS 11
16-bit	$2^{16} - 1 = 65535$	Registers 5, 3, 2, 0	PRBS 16
20-bit	$2^{20} - 1 = 1048575$	Registers 3, 0	PRBS 20
21-bit	$2^{21} - 1 = 2097151$	Registers 2, 0	PRBS 21

The **Data Source** selection for PRBS data from the menus is **PN09**, ....

Simple data patterns such as binary 0 strings or 1 strings can also be used as internal modulation data. The **Data Source** selection from the menus is **ALL 0**, **ALL 1**. A variable bit string with a maximum length of 64 bits can be entered in an input field by selecting **Pattern**.

### Internal Modulation Data from Lists

Internal modulation data can be generated and stored in the form of binary lists. A separate file is created for each list and held on the R&S Signal Generator hard disk. The file name can be defined by the user.

The **Data Source** selection from the menus is **Data List**. When this menu item is chosen the **Select Data List** button appears; this opens the file-selection window for data lists. A list can be created and edited in the **Data List Editor**, which is accessed from the menu via the **List Management** or **Data List Management** button.

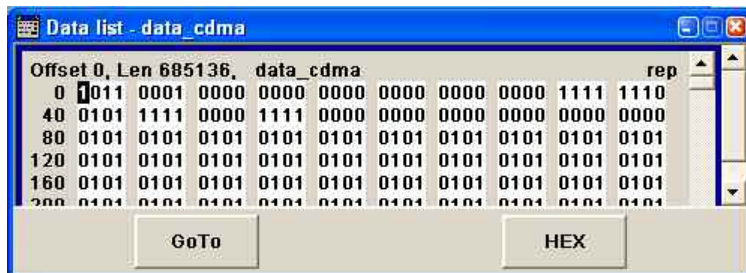

The maximum length of a data list is determined by the size of the data list memory (see data sheet). There is no restriction on the number of lists that can be stored.

## External Synchronous Modulation Data

### External Serial Modulation Data via the DATA Connector

For **Custom Digital Modulation**, serial modulation data can be supplied bit-by-bit via the DATA connector. The **Data Source** selection from the menu is **Extern Serial**.



In the case of modulation modes with more than 1 bit/symbol, the most significant bit (MSB) must be fed in first (MSB first).

The clock reference (symbol clock) used to read in the data can be either internal or external.

External serial data is output on the PARDATA pins of the AUX I/O interface as parallel data LSB-justified.

The maximum data rate for serial data processing can be found in the data sheet.

### External Parallel Modulation Data via the AUX I/O Interface

For **Custom Digital Modulation**, parallel data can be supplied symbol-by-symbol via the AUX I/O interface (D0 – D9). The **Data Source** selection from the menu is **Extern Parallel**.



In the case of modulation modes with fewer than 10 bits/symbol, the data must be applied LSB-justified. In the case of 8-PSK modulation for example (3 bits/symbol) only data lines D0, D1 and D2 are used.

The clock reference (symbol clock) used to read in the data can be either internal or external.

External parallel data is output on the DATA connector serially. However, there is a maximum data rate above which serial data processing becomes impossible and the DATA connector becomes high-impedance. The maximum data rate for parallel data processing is shown in the data sheet.

## Clock Signals

The clock reference used for generating the timing pulse can be either internal or external (**Clock Source** selection from the menu: **Internal / External**).

### Internal clock reference



When the internal clock reference is selected, the clock signals generated by the R&S Signal Generator are output on the following connectors:

CLOCK (front panel)	Bit clock
CLOCK OUT (rear panel)	Choice of bit clock or symbol clock
BITCLK (AUX I/O interface, rear panel)	Bit clock
SYMBCLK (AUX I/O interface, rear panel)	Symbol clock

The clock output signals are assigned in the menu sequence **Setup-Environment - Global Trigger/Clock/External Inputs - USER Marker /AUX I/O Settings**.

### External clock reference



When the external clock reference is selected, it is always supplied via the CLOCK connector on the front panel. The internal clocks synchronized to it are output on the following connectors:

CLOCK OUT (rear panel)	Choice of bit clock or symbol clock
BITCLK (AUX I/O interface, rear panel)	Bit clock
SYMBCLK (AUX I/O interface, rear panel)	Symbol clock

The active edge of the external clock signal on the CLOCK input is selectable (menu **Setup-System-Global Trigger/Clock/External Inputs**). Internally the rising edge is always taken as the active edge. The active rising edge of the internal clocks is therefore synchronized with either the rising or the falling edge of the external clock reference. A symbol clock can be supplied externally or, if internally generated or externally asynchronous data is being fed in, a multiple of a symbol clock can be supplied.

In order for the clock synthesizer on the R&S Signal Generator to be synchronized correctly, the external clock reference must first be applied and the correct symbol rate must then be set. Until this has been done the external clock source must not be selected (**Clock Source External**).

---

#### Note:

*The symbol rate set must not deviate from the symbol rate of the external signal by more than 2% (see also data sheet).*

---

The synchronization of data signals and clock signals for the various data sources and clock sources is described in the following section.

## Synchronizing Data Signals and Clock Signals

When selecting data signals and clock signals, the following operating modes are possible:

- Internal clock and internal data
- Internal clock and external synchronous data
- External clock and external synchronous data
- External clock and either internal data or external asynchronous data

### Internal Clock and Internal Data

When internal data is selected, this data is output in serial mode on the DATA connector or in parallel mode on the PARADATA pins of the AUX I/O interface (**Custom Digital Modulation**).

In modulation modes with fewer than 10 bits/symbol, the parallel data is output LSB-justified. In the case of 8-PSK modulation for example (3 bits/symbol) only data lines D0, D1 and D2 are used.

In the following example, the diagram shows the output signals of an 8-PSK modulation (3 bits per symbol) on the serial DATA interface. The positive edge of the clock is always used when outputting data. The data source is a data list with 15 bits = 001 010 100 101 110 (5 symbols).

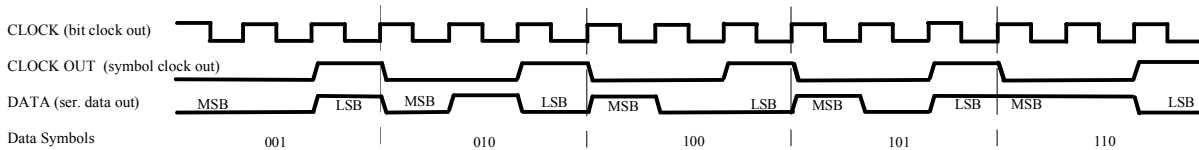

Fig. 4-2 Output signal on the serial data interface and clock output signals on the AUX I/O interface

There is a maximum data rate above which serial data processing becomes impossible. This data rate can be found in the data sheet. If the rate is exceeded the DATA connector becomes high-impedance, and the output on the CLOCK connector is the symbol clock instead of the bit clock.

In the following example, the diagram shows the output signals of an 8-PSK modulation (3 bits per symbol) on the parallel interface. The data source is a data list with 15 bits = 001 010 100 101 110 (5 symbols).

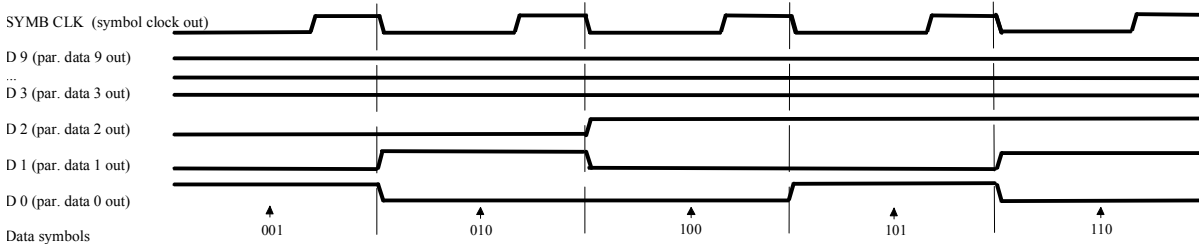

Fig. 4-3 Data and clock output signals on the parallel AUX I/O interface

In order for parallel external data to be retrieved correctly the rising edge of the symbol clock must be used, since the timing between the falling edge of the symbol clock and the data switch on the parallel interface is undefined.

## Internal Clock and External Synchronous Data

### External serial data

When serial data for **Custom Digital Modulation** is being fed in via the DATA connector on the front panel, the symbol clock acts as a scanning pulse (strobe) so as to mark the least significant bit in a symbol.

The clock signals are output on the CLOCK and CLOCK OUT connectors (front panel and rear panel respectively, choice of bit clock or symbol clock on the latter) and on the BITCLK or SYMBCLK pins on the AUX I/O interface. Optimum timing is achieved from using the output signal on the CLOCK connector on the front panel. The setup and hold times (see following diagram,  $t_{\text{setup}}$  and  $t_{\text{hold}}$ ) that must be maintained in the R&S Signal Generator to ensure that the serial data is accepted correctly can be found in the data sheet.

The following diagram illustrates the timing ratios between data and clock when serial data is being supplied from an external source and the internal clock source is being used.

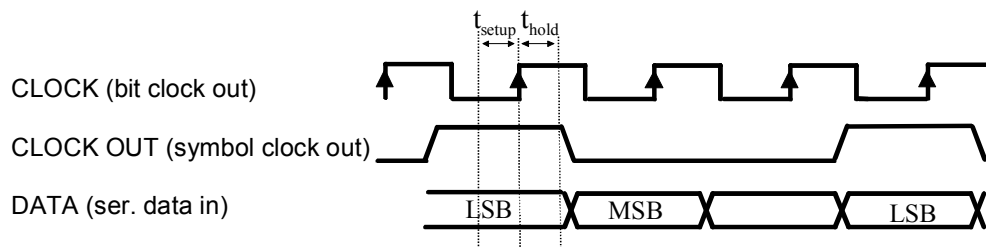

Fig. 4-4 External serial data and the clock signals which are output (bit clock and symbol clock). The setup time ( $t_{\text{setup}}$ ) and hold time ( $t_{\text{hold}}$ ) can be found in the data sheet.

### External parallel data

When parallel data for **Custom Digital Modulation** is being fed in via the AUX I/O interface (D0 – D9), the internal symbol clock is used.

The symbol clock is output on the CLOCK OUT connector (rear panel, choice of bit clock or symbol clock) and on the SYMBCLK pin on the AUX I/O interface. Optimum timing is achieved by using the symbol clock on the SYMBCLK pin on the AUX I/O interface. The setup and hold times (see following diagram,  $t_{\text{setup}}$  and  $t_{\text{hold}}$ ) that must be maintained in the R&S Signal Generator to ensure that the serial data is accepted correctly can be found in the data sheet.

The following diagram illustrates the timing ratios between data and clock when parallel data is being supplied from an external source and the internal clock source is being used.

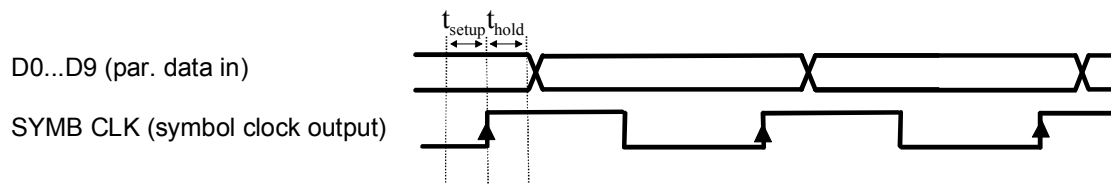

Fig. 4-5 External parallel data, internal clock signal and the clock signal that is output on the AUX I/O interface. The setup time ( $t_{\text{setup}}$ ) and hold time ( $t_{\text{hold}}$ ) can be found in the data sheet.

**External Clock and External Synchronous Data**

When synchronous modulation data is being fed in from an external source for **Custom Digital Modulation**, clock generation in the R&S Signal Generator can be synchronized on the rising or falling edge of an external symbol clock. The clock reference is supplied on the CLOCK connector (front panel).

The clock signals generated as a result are output on the CLOCK OUT connector (rear panel, choice of bit clock or symbol clock) and on the BITCLK or SYMBCLK pins on the AUX I/O interface.

**External serial data**

The following diagram illustrates the timing ratios between data and clock when serial data is being supplied from an external source and an external reference clock is being used.

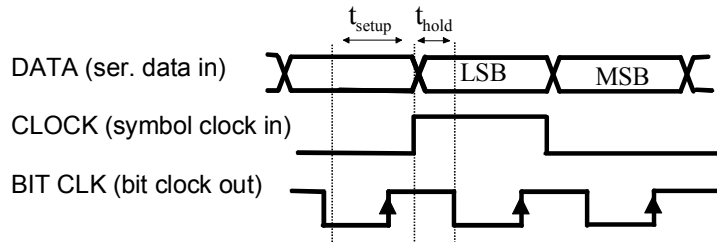

Fig. 4-6 External serial data and external symbol clock - 3 bits/symbol with high and low active **symbol clock** for marking the LSB. The data and the symbol clock must change state simultaneously. The setup time ( $t_{setup}$ ) and hold time ( $t_{hold}$ ) can be found in the data sheet.

A bit clock is generated from the externally supplied symbol clock and is used for reading the serial data into the R&S Signal Generator. The active edge of this bit clock is located ahead of the symbol clock.

**External parallel data**

The following diagram illustrates the timing ratios between data and clock when parallel data is being supplied from an external source and an external reference clock is being used.

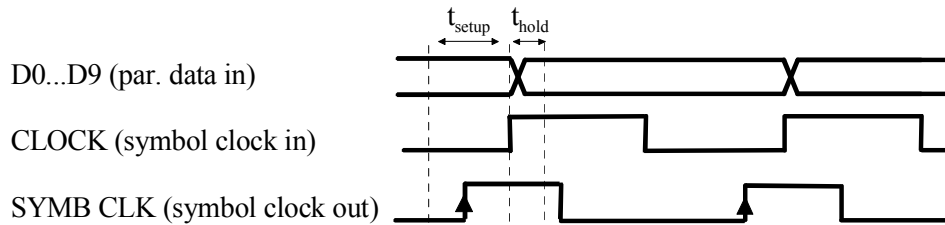

Fig. 4-7 External parallel data with high and low active external symbol clock. The setup time ( $t_{setup}$ ) and hold time ( $t_{hold}$ ) can be found in the data sheet.

The R&S Signal Generator uses the externally supplied symbol clock to generate an internal symbol clock that defines the sampling points at which the parallel data is read into the R&S Signal Generator. These sampling points are also located a little ahead of the external symbol clock.

## External Clock and Internal or External Asynchronous Data

If the modulation data is generated internally or supplied asynchronously from an external source, clock generation in the R&S Vector Signal Generator can be synchronized on an external symbol clock, or a multiple thereof, which is fed in on the CLOCK connector (front panel). Synchronization can be based on the rising edge or falling edge according to choice. The maximum permissible multiple symbol clock can be found in the data sheet.

## Control Signals

The following control signals are processed in the R&S Signal Generator:

- **Burst Gate** and **Level Attenuation** for power ramping
- **CW** for controlling the CW (continuous wave) mode  
The **CW** signal turns off digital modulation. The RF signal is output in unmodulated form. In case of standards in which it is possible to switch between different modulation modes, the signal is output only and cannot be supplied from an external source. In such cases it indicates the modulation mode internally (standard GSM: signal high (1) = modulation mode GMSK and signal low (0) = modulation mode 8PSK EDGE).

The CW control signal is generated internally and fed to the AUX I/O interface. The control signals for power ramping can be provided externally for **Custom Digital Modulation** only. When generated internally the signals are output on the AUX I/O interface.

A dedicated internal **Control Data Editor** is provided for defining the control signals. This editor with its intuitive graphical interface can be used to define and save control signals. Definition by generating or editing a binary list is no longer necessary (though it is still possible via the IEC bus).

A separate file with the file extension \*.dm\_iqc is created for each defined control signal and held on the R&S Signal Generator hard disk.

If the **Component Data Editor** is used, the **Control Data Editor** is integrated with it. The defined control data is not held separately, but stored with the data structure. This applies both to signals of the Data Editor Realtime and the Data Editor Offline.

## Power Ramping and Level Attenuation

In TDMA radio networks it is necessary to control the RF output signal envelope synchronously for the purpose of digital modulation. The signals **Burst Gate** and **Lev Att** are used for this. These signals are internally generated. In case of **Custom Digital Modulation** they can also be supplied from an external source via the AUX I/O interface.

When power ramping is enabled, a ramp is generated whenever there is a data switch on the **Burst** signal (from high to low or low to high). The steepness of this ramp can be adjusted. Power ramping is enabled and configured in the **Power Ramp Control** submenu.

The **Lev\_Att** signal is used to control a defined level attenuation. If level attenuation is enabled, the modulation signal level is attenuated by a defined value if the **Lev Att** signal is high. The level attenuation value is defined in the **Power Ramp Control** menu. For the **GSM/EDGE** standard a maximum of 7 different level attenuation values can be defined and allocated separately to the 8 slots quite independently of one another. Level attenuation is enabled either in the **Power Ramp Control** menu (Custom Digital Modulation) or in the Burst Editor (GSM/EDGE).



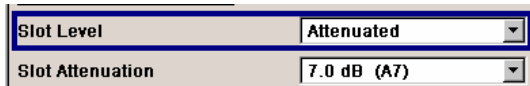

Level attenuation enables to simulate radio stations located at various distances.

The diagram below shows an example of how the power ramping signals work.

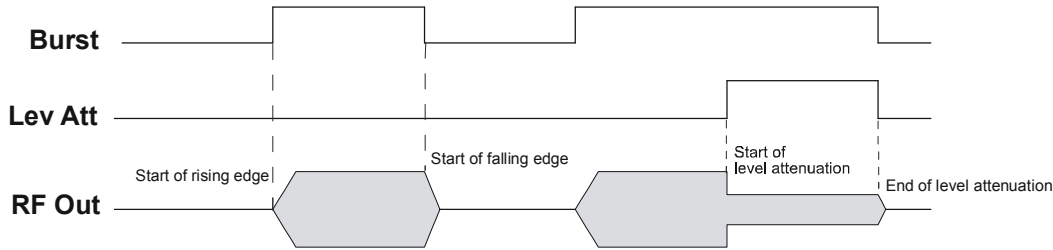

Fig. 4-8 Signal behavior when power ramping is enabled. The **Burst** Gate signal defines the start of the rising and falling edges of the envelope, and the **Lev Att** signal defines the start and end of level attenuation. The level attenuation value is defined in the **Power Ramp Control** menu.

## Trigger Signals

In the R&S Signal Generator, trigger signals are internally generated or externally supplied signals which start signal generation at a particular point in time.

Signal generation can also take place without triggering, in which case the signal is then generated in full after modulation is powered up. A trigger event either has no effect on signal generation (menu setting **Trigger Mode Auto**) or triggers a signal restart (menu setting **Trigger Mode Retrigger**).

If signal generation is triggered, the signal is continuously generated after the first trigger. In the **Armed\_Auto** mode, a further trigger event has no effect. In the **Armed\_Retrigger** mode, every additional trigger event triggers a restart of the signal. In both cases, triggering can be reset to the initial state (**armed**), i.e. signal generation is stopped and the instrument waits for the next trigger to start signal generation anew.

The status of signal generation (**Running** or **Stopped**) is displayed for all trigger modes in the corresponding trigger menu of the digital standard currently switched on. The signal generation status particularly with an external trigger can thus be checked.

Internal and external trigger sources are available for triggering.

- Internally, triggering is carried out manually by pressing the **Execute Trigger** button (menu selection **Internal**).
- External trigger signals can be fed in via the TRIGGER 1 and 2 connectors on the front and rear panels (menu selection **External**).

The effect of a restarted trigger signal in the **Retrigger** trigger mode can be suppressed for a definable number of symbols (menu setting (**External**) **Trigger Inhibit**). By this means the trigger can be suppressed for a definable number of frames, for example in the course of base station tests, and yet the signal can still be generated synchronously. In each frame the base station generates a trigger which would cause a signal generation restart every time but for the suppression.

**Example:** Entering 1000 samples means that after a trigger event, any subsequent trigger signal is ignored for the space of 1000 samples.

## Marker Output Signals

The R&S Signal Generator generates user-definable marker output signals which can be used to synchronize external instruments. By this means a slot clock or frame clock can be set, for instance, or the start of a particular modulation symbol can be marked.

Four marker outputs are available. The outputs for markers 1 to 3 are defined, but marker 4 can be placed on one of the USER outputs according to choice.

### Path A

Markers 1/2	MARKER 1 / 2 BNC connectors on the front panel
Marker 3	MARKER 3 pin of the AUX I/O connector on the rear panel
Marker 4	USER1 BNC connector or USER2/3/4 pins of the AUX I/O connector on the rear panel according to choice

# Digital Modulation - Custom Digital Modulation

## Introduction - Custom Digital Modulation

The R&S Signal Generator can generate digital modulation signals with user-definable characteristics. Baseband filtering and the symbol rate can be set within wide limits.

The equipment layout for generating the digital modulation signals includes the options Baseband Main Module (B13) and Baseband Generator (B9/B10/B11).

When modulation is ON, a two-part level indication is shown in the header section of the display. This displays both the average power (LEVEL) and the peak envelope power (PEP) of the modulated output signal.



The difference between PEP and LEVEL depends on the modulation type and the filtering: Both values are pre-measured internally so that the displayed values match the true values in the signal. When external signals are used, they are replaced by PRBS data during pre-measurement.

## Modulation Types - Custom Digital Mod

The available predefined modulation types are ASK (amplitude shift keying), FSK (frequency shift keying), PSK (phase shift keying) and QAM (quadrature amplitude modulation). Additionally, a user defined modulation mapping can be applied (see ["User Mapping"](#)).

The actual modulation procedure is described by mapping, which assigns I and Q values (PSK and QAM) or frequency shifts (FSK) to every modulation symbol that occurs. This is represented graphically in the constellation diagrams.

The mapping for the selected modulation type is displayed in the **More...** submenu in the **Modulation** menu section (see ["More - Modulation Type - Digital Modulation"](#), page 4.213)

The QAM procedures 16QAM, 32QAM, 64QAM have been produced in accordance with ETSI standard ETS 300429 for digital video broadcasting (DVB). The QAM procedures 256QAM and 1024QAM are not specified in this standard, but have been produced according to the same basic principles.

In the case of all FSK procedures, the user can set the symbol rate  $f_{\text{SYMB}}$  up to a maximum value (see data sheet). If MSK is selected, the frequency deviation (**FSK deviation**) cannot be set since it is permanently set to  $\frac{1}{4}$  of the symbol rate.

Table 4-1 Modulation type and associated mapping

**PSK**

**BPSK**  
1 bit per symbol

SOUR:BB:DM:FORM BPSK

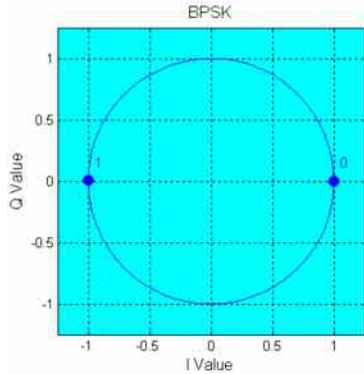

**QPSK EDGE**  
2 bits per symbol  
3pi/4 rotation

SOUR:BB:DM:FORM QEDGE

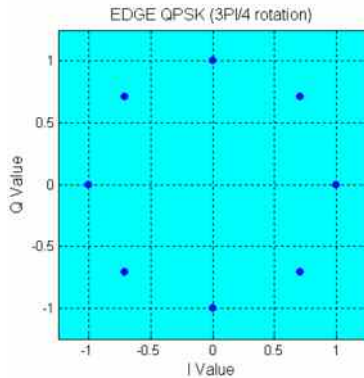

**pi/2-DBPSK**  
1 bit per symbol  
Differential coding, pi/2 rotation

SOUR:BB:DM:FORM P2DB

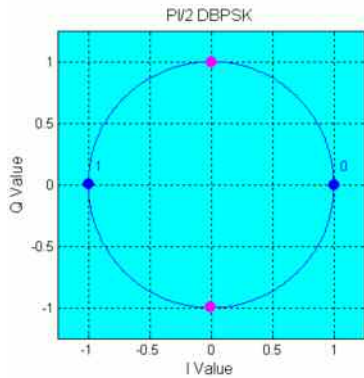

**QPSK**  
2 bits per symbol

SOUR:BB:DM:FORM QPSK

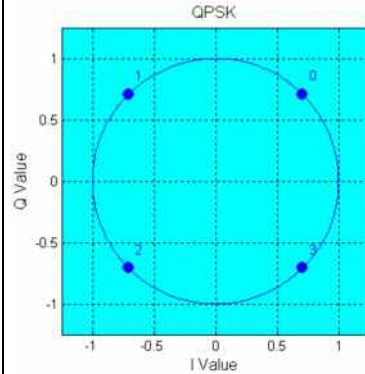

**OQPSK**  
2 bits per symbol  
Q offset

SOUR:BB:DM:FORM OQPSK

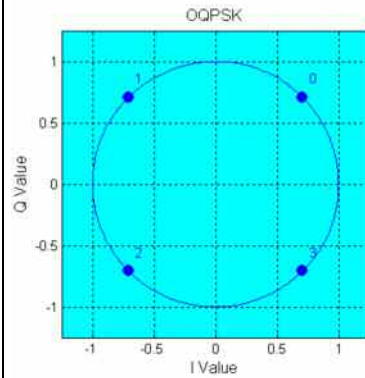

**pi/4-DQPSK**  
2 bits per symbol  
Differential coding, pi/4 rotation

SOUR:BB:DM:FORM P4DQ

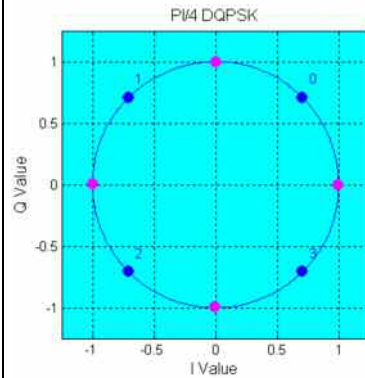

**QPSK 45° Offset**  
2 bits per symbol  
45° rotation

SOUR:BB:DM:FORM QPSK45

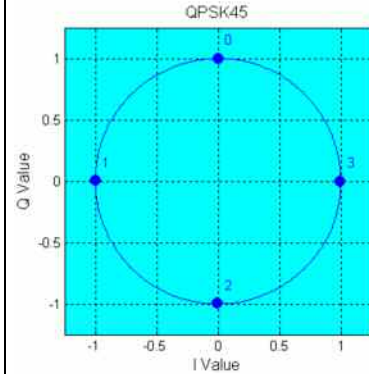

**pi/4-QPSK**  
2 bits per symbol  
pi/4 rotation

SOUR:BB:DM:FORM P4QP



**pi/8-D8PSK**  
3 bits per symbol  
Differential coding, pi/8 rotation

SOUR:BB:DM:FORM P8D8

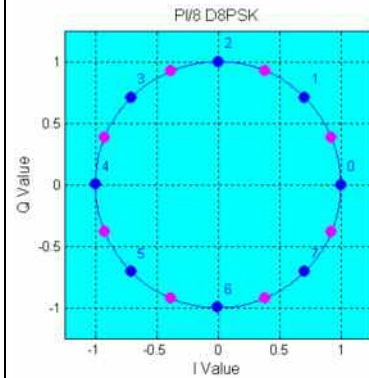

8PSK

3 bits per symbol

SOUR:BB:DM:FORM PSK8

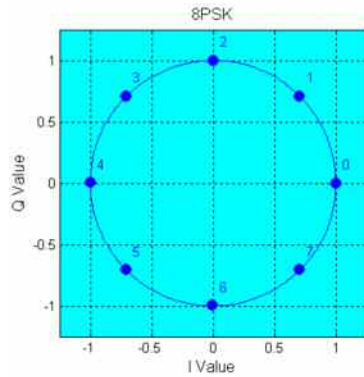

8PSK EDGE (3pi/8 8PSK)

3 bits per symbol  
Edge coding, 3pi/8 rotation

SOUR:BB:DM:FORM P8ED

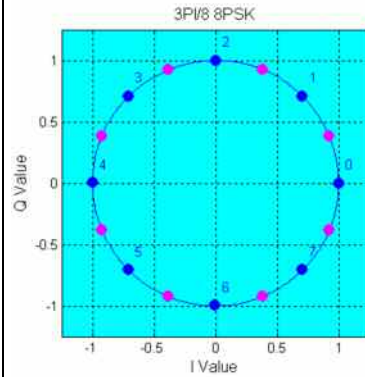

QAM

16QAM

4 bits per symbol

SOUR:BB:DM:FORM QAM16

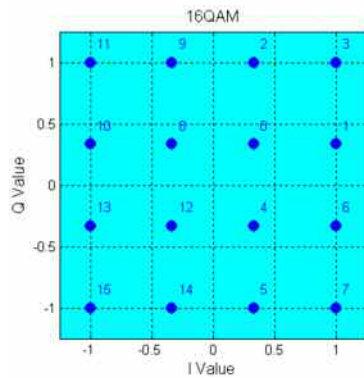

16QAM EDGE

4 bits per symbol, pi/4 rotation

SOUR:BB:DM:FORM QAM16EDGE

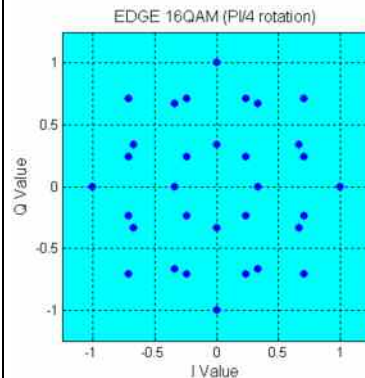

32QAM

5 bits per symbol

SOUR:BB:DM:FORM QAM32

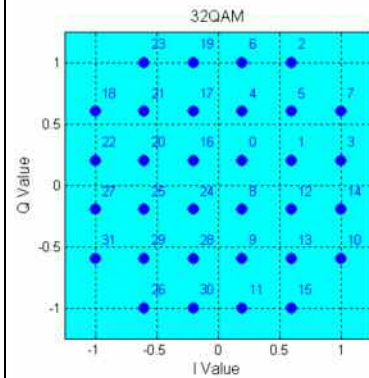

32QAM EDGE

5 bits per symbol, -pi/4 rotation

SOUR:BB:DM:FORM QAM32EDGE

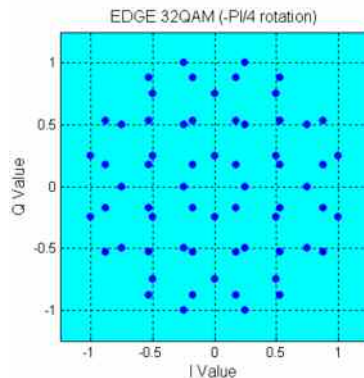

64QAM

6 bits per symbol

SOUR:BB:DM:FORM QAM64

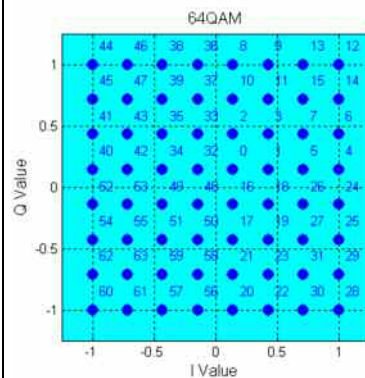

128QAM

7 bits per symbol

SOUR:BB:DM:FORM QAM128

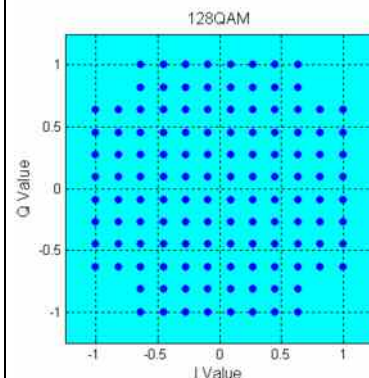

256QAM

8 bits per symbol

SOUR:BB:DM:FORM QAM256

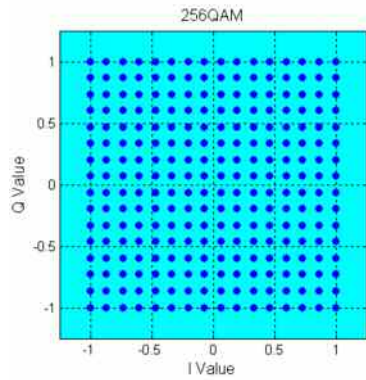

1024QAM

10 bits per symbol

SOUR:BB:DM:FORM QAM1024

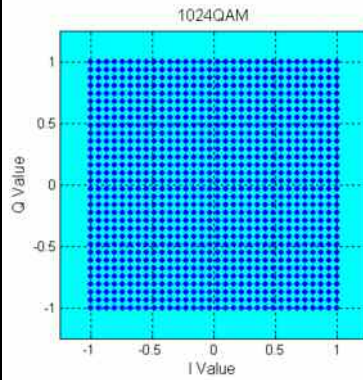

FSK

**Note:**

*In addition to the following FSK modulations, a variable FSK modulation with definable deviation per symbol is available.*

MSK

1 bit per symbol  
FSK deviation

SOUR:BB:DM:FORM MSK  
SOUR:BB:DM:FSK:DEV 0.1 MHz

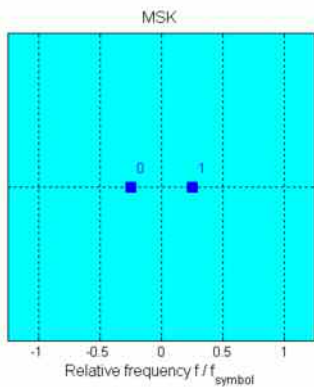

2FSK

1 bit per symbol

SOUR:BB:DM:FORM FSK2

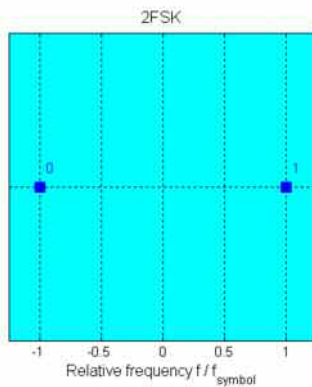

4FSK

2 bits per symbol

SOUR:BB:DM:FORM FSK4

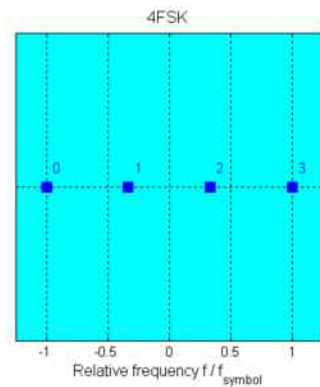

## User Mapping

A user defined modulation mapping file can also be selected as modulation mapping source. The user modulation mapping file must have extension \*.vam and can be created with the R&S mapping wizard. The mapping wizard (mapwiz) is a tool from Rohde & Schwarz designed for editing modulation schemes (e.g. QPSK, 32QAM). Its main purpose is the assignment of logical symbol numbers to constellation points and the selection of modulation specific parameters.

Beyond this it supports the creation of nearly any arbitrarily chosen constellation diagram. The output of mapwiz is a mapping file (\*.vam) that can be imported on a Rohde & Schwarz Signal Generator SMx with option SMx-B9/B10/B11.

The program was developed on a 32-bit Microsoft Windows platform under MATLAB.

For more information, refer to the description "Introduction to "mapwiz" Mapping Editor" on the Rohde&Schwarz Internet page.

## Coding - Custom Digital Mod

Modulation symbols are coded directly before I and Q values or frequency shifts are assigned. Coding is thus directly related to modulation methods, which is the reason why codings are not freely combinable with modulation methods. The following table shows which of the coding combinations are available and defines the modulation types for which the various coding procedures can be used.

In the notation used below  $a_n$  denotes the n-th input symbol and  $b_n$  denotes the correspondingly coded output symbol. Individual bits in the symbols from the LSB (least significant bit) to the MSB (most significant bit) are denoted by  $a_{0n}$ ,  $a_{1n}$  and so on. The same applies to the output symbols.

Table 4-1 Permissible coding combinations for modulation symbols and modulation type

	OFF	Differ- ence	Phase differ- ence	Differ- ence + Gray	Gray	GSM	NADC, PDC, PHS, TETRA, APCO25 (PSK), PWT	TFDS/ TETRA	INMARSAT, ICO, WCDMA 3GPP, cdma2000	VDL	APCO25 (FSK)
ASK	X	X		X	X						
BPSK	X	X		X	X						
$\pi/2$ DBPSK	X				X						
QPSK	X	X		X	X				X		
QPSK $45^\circ$ Offset	X	X		X	X				X		
$\pi/4$ QPSK	X	X			X						
$\pi/4$ DQPSK	X				X		X	X			
8PSK	X	X		X	X					X	
8PSK_EDGE	X										
$\pi/8$ D8PSK	X				X						
MSK	X	X		X	X	X					
2FSK	X	X		X	X	X					
4FSK	X	X		X	X						X
16QAM	X	X	X	X	X						
32QAM	X	X	X	X	X						
64QAM	X	X	X	X	X						
256QAM	X	X	X	X	X						
1024QAM	X	X	X	X	X						



**Modulation type  $\pi/4$ DQPSK**

With differential coding switched on at the same time, a constellation diagram is obtained for  $\pi/4$ DQPSK which is similar to that obtained for 8PSK. Phase shifts are however assigned to the individual modulation symbols. The following tables show the assignment of modulation symbols to phase shifts of the I/Q vector in relation to the selected coding.

Table 4-1 Phase shifts for  $\pi/4$ DQPSK

Modulation symbol (binary indication: MSB, LSB)	$a_n$	00	01	10	11
Phase shifts without coding		+ 45°	+135°	- 135°	-45°
Phase shifts with coding NADC, PDC, PHS, TETRA or APCO25 (PSK)		+ 45°	+135°	-45°	- 135°
Phase shifts with coding TFTS		- 135°	+135°	-45°	+ 45°

**Coding algorithms**

Common coding types are listed in the following table.

Table 4-1 Coding algorithms

Coding	Coding algorithm	Applicable for K bit/symbol
NONE	$b_n = a_n$	k = 1...8
Differential	$b_n = (a_n + b_{n-1}) \text{ modulo } 2^k$	k = 1...7
Differential + Gray	Gray coding with additional differential coding	k = 1...7
GSM	$dc_n = \text{not}(d_n \text{ exor } d_{n-1})$	k = 1

**Example 1:** Differential coding for QPSK modulation with K = 2 bit/symbol

Decimal display; value range for modulation symbols

$$a_n \in \{0; 1; 2; 3\}$$

Recursive coding is defined as follows:  $b_n = (a_n + b_{n-1}) \text{ modulo } 4$ .

Depending on the state of a preceding modulation symbol  $b_{n-1}$  the coded modulation symbol  $b_n$  is obtained for example from modulation symbol  $a_n = 2$  as follows:

$a_n = 2$	$b_{n-1}$	$b_n$
	0	2
	1	3
	2	0
	3	1

By means of differential coding, the assignment between modulation symbols and phase differences shown in the following table is generated:

Modulation symbol $a_n$ (binary, MSB, LSB)	00	01	10	11
Phase difference	0°	90°	180°	270°



**Example 2:** Gray and differential coding for 8PSK modulation

First, a gray coding is performed according to the gray code. Afterwards, a differential coding is performed according to the recursive coding algorithm quoted above. The assignment between modulation symbols and phase differences shown in the following table is generated:

<b>Modulation symbol <math>a_n</math> (binary, MSB, LSB)</b>	000	001	010	011	100	101	110	111
<b>Phase difference</b>	0°	45°	135°	90°	270°	315°	225°	180°

**Differential coding according to VDL** can be used for modulation types with 3 bits/symbol, e.g. 8PSK.

Table 4-1 Differential coding according to VDL

<b>Modulation symbol <math>d_n</math> (binary, MSB, LSB)</b>	000	001	010	011	100	101	110	111
<b>Phase difference</b>	0°	45°	135°	90°	315°	270°	180°	225°

**Phase differential coding** INMARSAT and PHASE DIFF correspond to system standards Inmarsat-M and DVB according to ETS 300 429. The INMARSAT coding can generally be used for modulation types with 2 bits/symbol, such as QPSK. It uses the following algorithm.

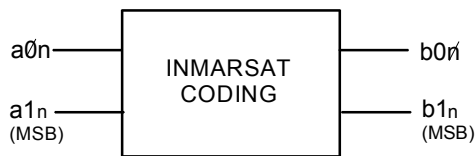

$$b_{1n} = [\text{NOT } (a_{1n} \text{ EXOR } a_{0n}) \text{ AND } (a_{1n} \text{ EXOR } b_{1(n-1)})] \text{ OR } [(a_{1n} \text{ EXOR } a_{0n}) \text{ AND } (a_{1n} \text{ EXOR } b_{0(n-1)})]$$

$$b_{0n} = [\text{NOT } (a_{1n} \text{ EXOR } a_{0n}) \text{ AND } (a_{0n} \text{ EXOR } b_{0(n-1)})] \text{ OR } [(a_{1n} \text{ EXOR } a_{0(n-1)}) \text{ AND } (a_{0n} \text{ EXOR } b_{1(n-1)})]$$

## Baseband Filter - Custom Digital Mod

The R&S Signal Generator offers a wide selection of predefined baseband filters. The filter characteristic for the selected filter is displayed in the **More...** submenu in the **Filter** menu section (see "More - Filter - Digital Modulation", page 4.215). Additionally, a user defined filter can be selected (see "User filter").

The following table shows the filters that are available, together with the associated parameters and IEC bus commands. The filter characteristic is displayed in graphical form.

Table 4-2 Baseband filter

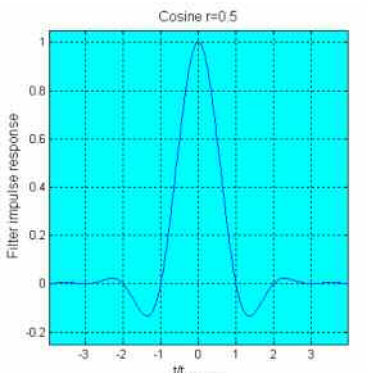
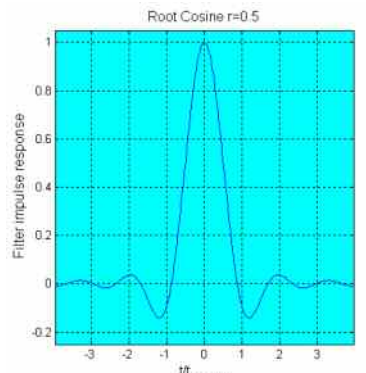
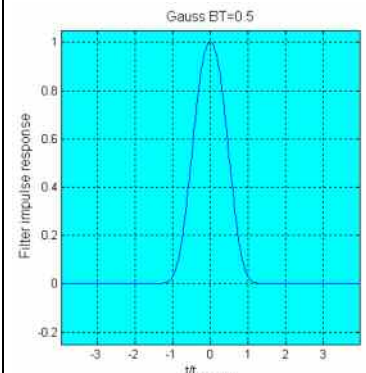
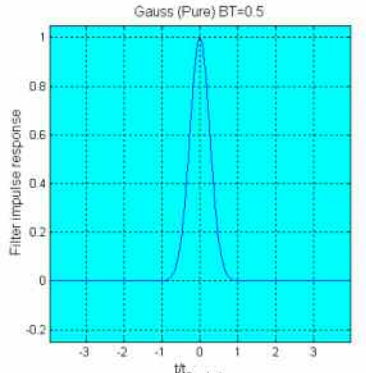
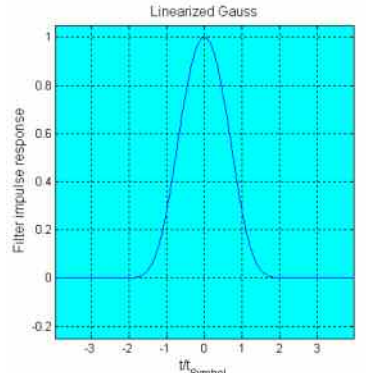
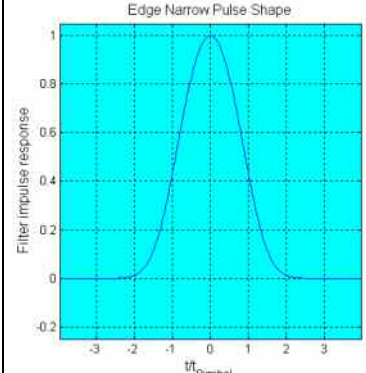
<p><b>Cosine</b> Roll Off Factor</p> <p>SOUR:BB:DM:FILT:TYPE COS SOUR:BB:DM:FILT:PAR: COS 0.99</p> 	<p><b>Root Cosine (<math>\sqrt{\cos}</math>)</b> Roll Off Factor</p> <p>SOUR:BB:DM:FILT:TYPE RCOS SOUR:BB:DM:FILT:PAR:RCOS 0.99</p> 	<p><b>Gauss (FSK)</b> B x T</p> <p>SOUR:BB:DM:FILT:TYPE GAUS SOUR:BB:DM:FILT:PAR:GAUS 2.5</p> 
<p><b>Pure Gauss</b> B x T</p> <p>SOUR:BB:DM:FILT:TYPE PGA SOUR:BB:DM:FILT:PAR:PGA 2.5</p> 	<p><b>Gauss Linearized</b></p> <p>SOUR:BB:DM:FILT:TYPE LGA</p> 	<p><b>Edge Narrow Pulse Shape</b></p> <p>SOUR:BB:DM:FILT:TYPE ENPShape</p> 

Edge Wide Pulse Shape

SOUR:BB:DM:FILT:TYPE EWPSHape

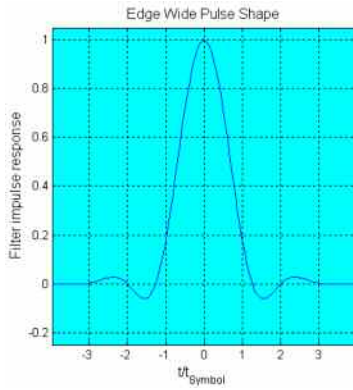

cdmaOne + Equalizer

SOUR:BB:DM:FILT:TYPE COE

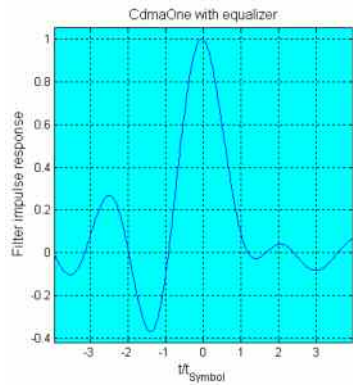

APCO25

Roll Off Factor

SOUR:BB:DM:FILT:TYPE APCO25  
SOUR:BB:DM:FILT:PAR:APC 0.5

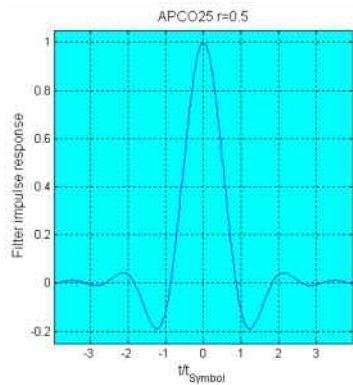

cdmaOne

SOUR:BB:DM:FILT:TYPE CONE

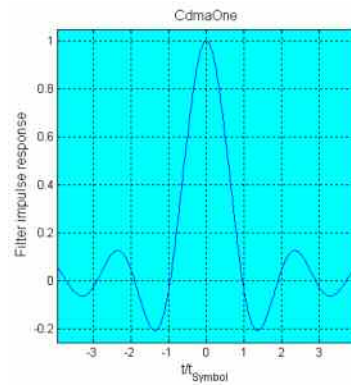

cdmaOne 705 kHz + Equalizer

SOUR:BB:DM:FILT:TYPE COFE

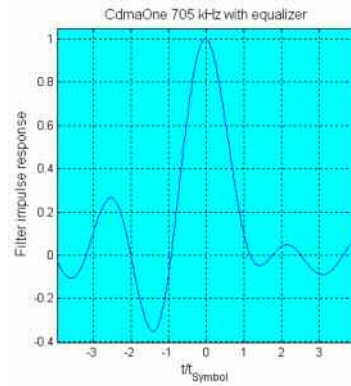

Split Phase

BxT

SOUR:BB:DM:FILT:TYPE SPH  
SOUR:BB:DM:FILT:PAR:SPH 0.15

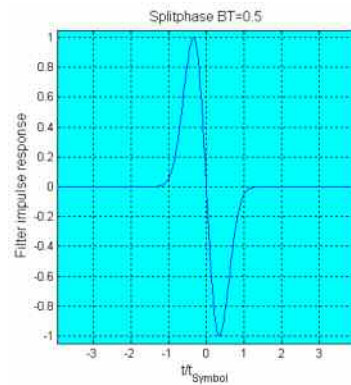

cdmaOne 705 kHz

SOUR:BB:DM:FILT:TYPE COF705

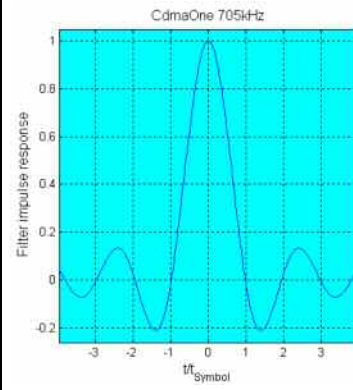

cdma2000 3X

SOUR:BB:DM:FILT:TYPE DM3x

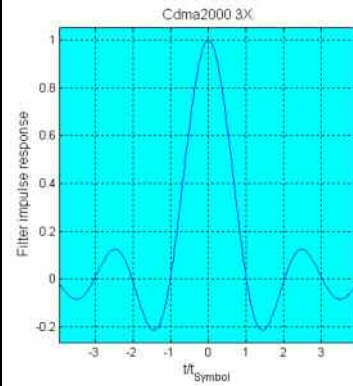

Rectangular

SOUR:BB:DM:FILT:TYPE RECT

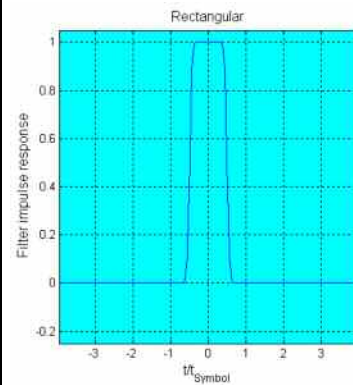

## Lowpass

SOUR:BB:DM:FILT:TYPE LPASS

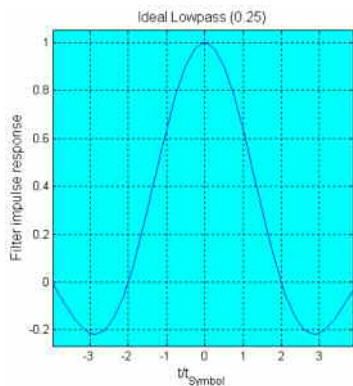

## Dirac

SOUR:BB:DM:FILT:TYPE DIRac

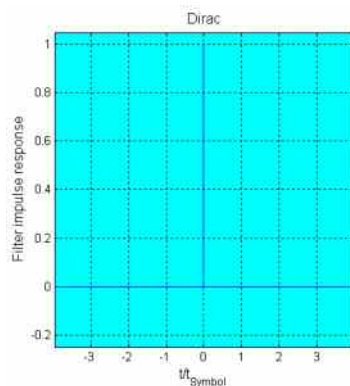

## User filter

The user filter file must have extension **\*.vaf** and can be created with the R&S filter wizard.

The filter wizard (filtwiz) is a tool from Rohde & Schwarz designed for creating filter files that can be imported on a R&S Signal Generator. Its main purpose is the conversion of user-defined finite impulse response (FIR) filters into the filter format (\*.vaf).

Beyond this filt wiz provides designs for standard filters (e.g. Root Raised Cosine, Gaussian) as well as a tool to automatically derive a receiver filter from a given transmitter filter with respect to the Nyquist condition for zero intersymbol interference (ISI).

The program was developed on a 32-bit Microsoft Windows platform under MATLAB.

For more information, refer to the description "Introduction to "filtwiz" Filter Editor" on the Rohde&Schwarz Internet page.

## Conflicting Settings - Custom Digital Mod

Having selected a modulation procedure, not every combination is possible when selecting the settings for the modulation parameters **Symbol Rate** and **Coding**. These restrictions inevitably give rise to conflicting settings if a parameter is changed and leads to a prohibited combination.

A conflicting setting is indicated by a message on the Info line in the display. The R&S Signal Generator displays the setting entered by the user, but the modulation signal actually generated does not correspond to this display. A conflict of settings can be triggered if the user changes a parameter inappropriately. The message disappears as soon as a conflict-free setting is entered. A list of the possible settings conflicts and messages in digital modulation can be found in chapter 9 "[Error messages](#)".

# Custom Digital Mod Menu

The menu for setting digital modulation can be opened either in the **Baseband** block or in the menu tree under Baseband.

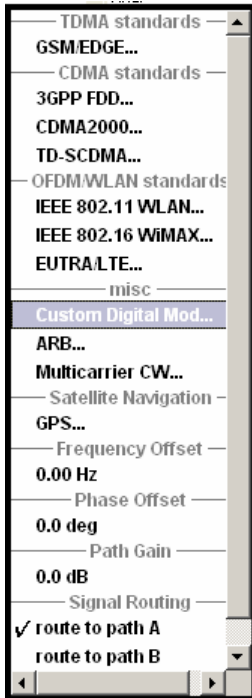

The **Custom Digital Modulation** menu enables direct selection of the data source, standard, symbol rate, coding, modulation type and filter. All other settings are entered in submenus which are called via **More** buttons.



The upper part of the menu is used for powering up digital modulation as well as for calling the default settings and user-defined standards.

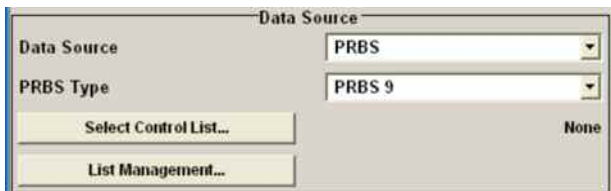

The data source is selected and set in the **Data Source** section.

The **List Management** button opens a submenu for calling the data editor and the file manager.



The middle part of the menu is used for selecting the standard, the symbol rate and the coding.



The modulation type is set in the **Modulation** section. The **More** button opens a submenu that displays the mapping for the selected modulation. This submenu can also be used to enable switching an RF signal between modulated and unmodulated.

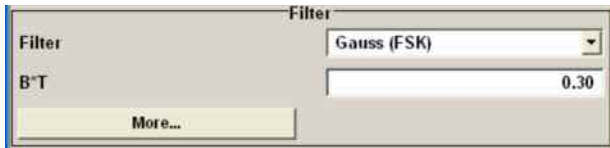

The filter is set in the **Filter** section.

The **More** button opens a submenu where the filter characteristic of the selected filter is displayed.



The buttons in the lower part of the menu open submenus for power ramping and for configuring triggers and clocks.

In each case the current setting is displayed next to the button.

## Custom Digital Modulation Main Menu

The upper part of the menu is used for powering up digital modulation as well as for calling the default settings and user-defined standards.

**State - Digital Modulation** Enables/disables digital modulation.

Switching on digital modulation turns off all the other digital standards (in case of two-path instruments, this affects the same path).

The digital modulation is generated in realtime (no precalculated signal), and therefore all parameter changes (in the ON state) directly affect the output signal.

Remote-control command:

SOUR:BB:DM:STAT ON

**Set To Default - Digital Modulation**

Calls default settings. The values are shown in the following table.

Remote-control command:

SOUR:BB:DM:PRES

Parameter	Value
State	Not affected by Set to Default
Data Source	PRBS 9
Standard	GSM
Symbol Rate	270.833 ksymb/s
Coding	GSM
Modulation Type	MSK
Filter	Gauss (FSK)
Filter Parameter BxT	0.3
Power Ramp Control	
Attenuation	15 dB
Ramp Time	1 sym
Ramp Function	Cosine
Fall Delay	0
Rise Delay	0
Source	Internal

Parameter	Value
State	Off
Trigger	
Mode	Auto
Source	Internal
Ext. Delay	0
Ext. Inhibit	0
Clock	
Source	Internal
Mode	Symbol

**Save/Recall - Digital Modulation**

Calls the **Save/Recall** menu.

From the **Save/Recall** menu the **File Select** windows for saving and recalling the complete settings in the **Custom Digital Modulation** menu can be called.

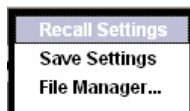

The Digital Modulation Settings are stored as files with the predefined file extension **\*.dm**. The file name and the directory they are stored in are user-definable.

The complete settings in the **Custom Digital Modulation** menu are saved and recalled.

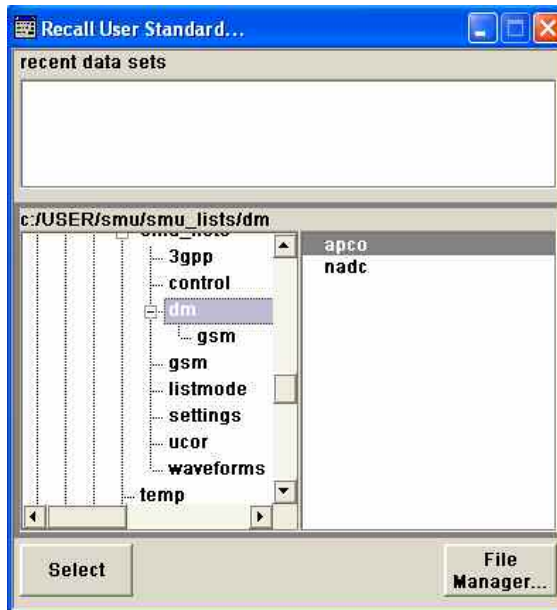

Remote-control commands:

```
MMEM:MDIR 'F:\gen\dig_mod\sett'
```

```
SOUR:BB:DM:SETT:CAT?
SOUR:BB:DM:SETT:DEL
SOUR:BB:DM:SETT:LOAD
SOUR:BB:DM:SETT:STOR
```



The data source is selected and set in the **Data Source** section. The parameters offered depend on the data source selected. The **More** button opens a submenu for calling the data editor and the file manager.

**Data Source - Digital Modulation**

Selects the data source (see also section "Data and Signal Sources in Baseband", page 4.186).

You may choose from the following data sources:

**All 0** 0 data or 1 data is internally generated.

**All 1** Remote-control command:  
SOUR:BB:DM:SOUR ONE | ZERO

**PRBS** PRBS data in accordance with the IUT-T with period lengths between  $2^9-1$  and  $2^{23}-1$  are internally generated.

**PRBS Type**

The length is selected in the **PRBS Type** input box.



Remote-control commands:  
SOUR:BB:DM:SOUR PRBS  
SOUR:BB:DM:PRBS 9|11|15|16|20|21|23

**Pattern**

A user-definable bit pattern with a maximum length of 64 bits is internally generated.

**Pattern**

The bit pattern is defined in the **Pattern** input box.

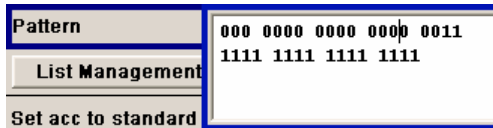

Remote-control command:  
SOUR:BB:DM:SOUR PATT  
SOUR:BB:DM:PATT #H77550,17

**Data List**

Data lists will be used.

**...Select Data**

Data lists can be generated internally in the data editor or externally.

Data lists are selected in the **File Select** window, which is called by means of the **Select Data** button.

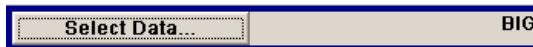

The **File Manager** is used to transmit external data lists to the R&S Signal Generator, and can be called within every File Select window by means of the **File Manager** button.

Remote-control command:  
SOUR:BB:DM:SOUR DLIS  
SOUR:BB:DM:DLIS:SEL "d\_list1"

**External Serial**

External serial data is supplied via the DATA connector.

Remote-control command:  
SOUR:BB:DM:SOUR SER



**External Parallel (AUX I/O)** External parallel data is supplied externally via the PARDATA pins on the AUX I/O interface.  
 Remote-control command:  
 SOUR:BB:DM:SOUR PAR

**List Management - Digital Modulation**

Calls the menu for managing data and control lists (see section "List Management - Digital Modulation Menu", page 4.217).



Remote-control command: n.a.

The middle part of the menu is used for selecting the standard, the symbol rate and the coding.

**Set acc. to Standard - Digital Modulation**

Selects a standard.  
 After selection, modulation parameters **Modulation Type**, **Symbol Rate**, **Filter** and **Coding** are automatically set in accordance with the standard.

If one of these parameters is subsequently altered, the display changes to User. The User setting can be saved to a file so that it can be recalled at some later time (**Save/Recall User...** button).

The following table shows the standards that are available, together with the associated settings of the modulation parameters.

Remote-control command:  
 SOUR:BB:DM:STAN PDC

Table 4-3 Standards - Custom Digital Modulation

Standard	Modulation	Symbol Rate	Filter	Coding	Parameter for IEC command
Bluetooth	2FSK, Deviation 160.0 kHz	1.0 Msym/s	Gauss, B*T = 0,5	OFF	BLUetooth
DECT	2FSK, Deviation 288.0 kHz	1.152 Msym/s	Gauss, B*T = 0,5	OFF	DECT
ETC (ARIB STD T55)	ASK, ASK Depth 100%	1.024 Msym/s	Split Phase, B*T = 2.0	OFF	ETC
GSM	MSK	270.833333 ksym/s	Gauss, B*T = 0.3	GSM	GSM
GSM EDGE	8PSK EDGE (3pi/8 8PSK)	270.833333 ksym/s	Gauss linear	OFF	GSMEdge
NADC	pi/4 DQPSK	24.3 ksym/s	SQR COS, $\alpha = 0.35$	NADC	NADC
PDC	pi/4 DQPSK	21.0 ksym/s	SQR COS, $\alpha = 0.50$	PDC	PDC
PHS	pi/4 DQPSK	192.0 ksym/s	SQR COS, $\alpha = 0.50$	PHS	PHS
TETRA	pi/4 DQPSK	18.0 ksym/s	SQR, $\alpha = 0.35$	TETRA	TETRa
WCDMA 3GPP	QPSK 45° Offset	3.84 Msym/s	SQR, $\alpha = 0.22$	WCDMA 3GPP	W3GPP
TD-SCDMA	QPSK 45° Offset	1.28 Msym/s	WCDMA 0.22	OFF	TCSCdma
cdma2000 Forward	QPSK	1.2288 Msym/s	cdmaOne + Equalizer	cdma2000	CFORward
cdma2000 Reverse	Offset QPSK	1.2288 Msym/s	cdmaOne	cdma2000	CREVerse
Worldspace	QPSK	1.84 Msym/s	SQR COS, $\alpha = 0.40$	OFF	WORLdspace
TFTS	pi/4 DQPSK	22.1 ksym/s	SQR COS, $\alpha = 0.40$	TFTS/ TETRA	TFTS

**Save/Recall User - Digital Modulation**

Calls the **Save/Recall User** menu.

From the **Save/Recall** menu the **File Select** windows for saving and recalling user-defined standards and the **File Manager** can be called.

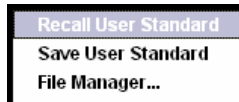

User standards are stored as files with the predefined file extension **\*.dm\_stu**. The file name and the directory they are stored in are user-definable.

**Remote-control commands:**

MMEM:MDIR 'F:\gen\gen\_lists\dm'

SOUR:BB:DM:STAN:ULIS:CAT?  
 SOUR:BB:DM:STAN:ULIS:DEL  
 SOUR:BB:DM:STAN:ULIS:LOAD  
 SOUR:BB:DM:STAN:ULIS:STOR

**Symbol Rate - Digital Modulation**

Selects the symbol rate.

The value range is dependent on the selected modulation type.

When the modulation type changes, the range is automatically redefined. If the set symbol rate is outside this range, an error message is generated and the maximum value for the newly chosen modulation type is automatically set.

Remote-control command:

```
SOUR:BB:DM:SRAT 15 MHz
```

**Coding - Digital Modulation**

Selects the coding (see section "[Coding - Custom Digital Mod](#)", page 4.200).

The menu offers only the coding settings that are permissible for the chosen modulation type. The other coding methods are grayed out.

If the system is subsequently switched to a modulation type for which the selected coding is not available, coding is automatically set to OFF.

Remote-control command:

```
SOUR:BB:DM:COD
```

The modulation type is set in the **Modulation** section. The parameters offered depend on what is currently selected. The **More...** button opens a submenu for displaying the user-defined mapping.

**Modulation Type - Digital Modulation**

Selects a modulation type.

The associated symbol mapping is displayed in the **More...** submenu (see also table [Modulation type and associated mapping](#), page 4.197).

If the coding that is set is not possible with the chosen modulation type, **coding** is set to **Off**.

You may choose from the following:

ASK, the PSK modulations BPSK, QPSK, QPSK 45° Offset, OQPSK, QPSK EDGE, pi/4-QPSK, pi/2-DBPSK, pi/4-DQPSK, pi/8-D8PSK, 8PSK, 8PSK EDGE, the QAM modulations 16QAM to 1024QAM, 16QAM EDGE, 32QAM EDGE and the FSK modulations MSK, 2FSK, 4FSK, as well as Variable FSK.

For selection "Variable FSK", the deviation of each symbol can be set in the **More...** submenu.

Remote-control command:

```
SOUR:BB:DM:FORM ASK
```

**Load User Mapping - Digital Modulation**

Selects user defined mapping table. This opens the **Select List File User Mapping** window in which the mapping table can be selected (see "[User Mapping](#)").

The button is only available if modulation type **USER** is selected.

Remote-control command:

```
SOUR:BB:DM:FORM USER
SOUR:BB:DM:MLIS:SEL "d_mod_list1"
```

The button **File Manager** calls the **File Manager** menu. The **File Manager** menu is used to display and delete files.

Remote-control command:

```
MMEM:MDIR 'F:\gen\gen_lists\dm'
SOUR:BB:DM:MLIS:CAT?
SOUR:BB:DM:MLIS:DEL m_list1
```

**ASK Depth - Digital Modulation**

Sets the modulation depth for ASK modulation.

Remote-control command:  
 SOUR:BB:DM:ASK:DEPT 100 PCT

**FSK Deviation - Digital Modulation**

Sets the frequency deviation for FSK modulation. The range of values depends on the chosen symbol rate (see data sheet).

Whenever **MSK** is selected, the deviation corresponds to 1/4 of the symbol rate and cannot be set.

Remote-control command:  
 SOUR:BB:DM:FSK:DEV 5 Hz

**More - Modulation Type - Digital Modulation**

Calls the submenu which displays the mapping of the currently selected modulation type and the digital modulation delay in the case of an external data source.

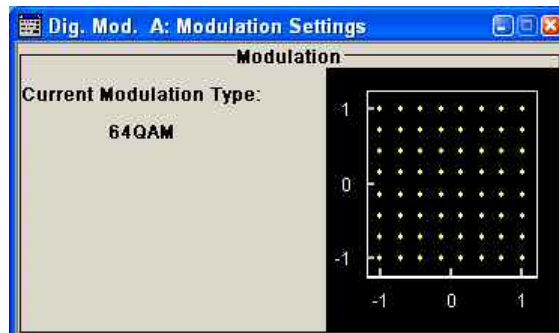

The **Modulation - CW Switching** section can be used to enable switching signal between modulated and unmodulated.

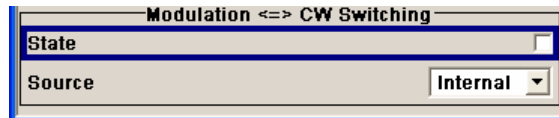

In case of selection **Variable FSK**, the FSK type and the deviation for each symbols is set in the **Variable FSK** section.

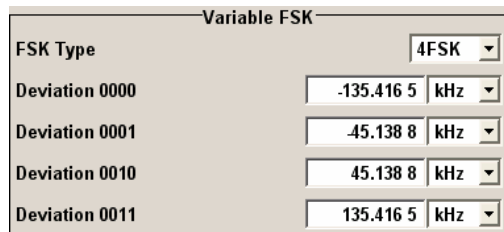

**FSK Type - Digital Modulation****(Variable FSK only)**

Selects the FSK modulation type for selection **Variable FSK**.

You may choose from 4FSK, 8FSK and 16FSK.

Remote-control command:

```
SOUR:BB:DM:FSK:VAR:TYPE FSK8
```

**Deviation xxxx - Digital Modulation****(Variable FSK only)**

Set the deviation of the associated symbol. The number of symbols depends on the selected modulation type. The value of each symbol is indicated in binary format.

Remote-control command:

```
SOUR:BB:DM:FSK:VAR:SYMB2:DEV 13E3
```

**Modulation Delay - Digital Modulation****(Data Source ext serial and ext parallel only)**

Displays the digital modulation delay from the data input to the I/Q output.

The value is displayed only if an external synchronous data source is selected. In this case the value represents the delay between the active clock edge for data and the corresponding peak I/Q value (associated with this data item) on the I/Q connectors.

Remote-control command:

```
SOUR:BB:DM:MDEL?
```

**Current Modulation Type - Digital Modulation**

Displays the currently selected modulation type together with its associated mapping.

Remote-control command: n.a.

The **Modulation ⇄ CW Switching** section is used to enable switching between modulated and unmodulated.

**State Mod - CW - Digital Modulation**

Enables switching between a modulated and an unmodulated signal.

Switching is carried out by a control signal (CW) that is defined internally in the control list or supplied from an external source via a user-defined input.

Remote-control command:

```
SOUR:BB:DM:SWIT:SOUR INT
SOUR:BB:DM:CLIS:SEL 'CLIST1'
SOUR:BB:DM:SWIT:STAT ON
SOUR:BB:DM:SWIT:SOUR EXT
SOUR:BB:DM:SWIT:STAT ON
```

**Source Mod - CW - Digital Modulation** Selects the CW control signal for switching between a modulated and an unmodulated signal.

**Internal** The CW signal in the control list is used for the control. The internal signal can be output on one of the user interfaces.

Remote-control command:  
SOUR:BB:DM:SWIT:SOUR INT

**External** The control signal on the CW pin of the AUX I/O connector is used (for two path instruments path A and B).

Remote-control command:  
SOUR:BB:DM:SWIT:SOUR EXT

**Filter - Digital Modulation** Selects the baseband filter (see also section "[Baseband Filter - Custom Digital Mod](#)", page 4.203).

Remote-control command:  
SOUR:BB:DM:FILT:TYPE COS

The filter is set in the **Filter** section.

**Filter Parameter - Digital Modulation** Sets the filter parameter.

The filter parameter offered (Roll Off Factor or B x T) depends on the currently selected filter type.

Remote-control commands:  
SOUR:BB:DM:FILT:PAR:APCO25 0.2  
SOUR:BB:DM:FILT:PAR:COS 0.35  
SOUR:BB:DM:FILT:PAR:GAUS 0.5  
SOUR:BB:DM:FILT:PAR:PGA 0.5  
SOUR:BB:DM:FILT:PAR:RCOS 0.35  
SOUR:BB:DM:FILT:PAR:SPH 2  
SOUR:BB:DM:FILT:PAR?

**Cut Off Frequency Factor - Digital Modulation** **(This feature is available for filter parameter Lowpass only.)**

Sets the value for the cut off frequency factor. The cut off frequency of the lowpass filter can be adjusted to reach spectrum mask requirements.

Remote-control command:  
SOUR:BB:DM:FILT:PAR:LPAS 0.5

**More - Filter - Digital Modulation**

Calls the menu for displaying the filter characteristic of the currently selected filter.

**Load User Filter- Filter - Digital Modulation**

Calls the menu **Select List File User Filter** for selecting a user-defined filter file with extension \*.vaf (see ["User filter"](#)). The button is only available if filter type **USER** is selected.

Remote-control command:

```
SOUR:BB:DM:FILT:TYPE USER
SOUR:BB:DM:FLIS:SEL user_filter3
```

The button **File Manager** calls the **File Manager** menu. The **File Manager** menu is used to display and delete files.

Remote-control command:

```
MMEM:MDIR 'F:\gen\gen_lists\dm'
SOUR:BB:DM:FLIS:CAT?
SOUR:BB:DM:FLIS:DEL user_filter3
```

**Current Filter Response**

Displays the filter characteristic of the currently selected filter.

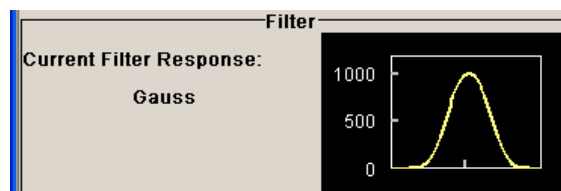

Remote-control command: n.a.

The lower part of the **Custom Digital Modulation** menu is used for setting triggers and clocks, as well as for power ramp settings.

**Power Ramp Control - Digital Modulation**

Calls the power ramp control menu (see section ["Power Ramp Control - Digital Modulation Menu"](#), page 4.226).

Remote-control command: n.a.

**Trigger/Marker - Digital Modulation**

Calls the **Trigger/Marker/Clock** menu. The **Trigger/Marker/Clock** menu is used to select the trigger source, set the time delay on an external trigger signal and configure the marker output signals (see section ["Trigger/Marker/Clock - Custom Digital Modulation Menu"](#), page 4.228).

Remote-control command: n.a.

**Execute Trigger - Digital Modulation**

Executes trigger manually. A manual trigger can be executed only when an internal trigger source and a trigger mode other than Auto have been selected.

Remote-control commands:

```
SOUR:BB:DM:TRIG:SOUR INT
SOUR:BB:DM:SEQ RETR
SOUR:BB:DM:TRIG:EXEC
```

**Clock - Digital Modulation** Calls the **Trigger/Marker/Clock** menu. The **Trigger/Marker/Clock** menu is used to select the clock source (see section "[Trigger/Marker/Clock - Custom Digital Modulation Menu](#)", page 4.228).  
Remote-control command: n.a.

## List Management - Digital Modulation Menu

The **List Management** menu is called from the **Digital Modulation** main menu.

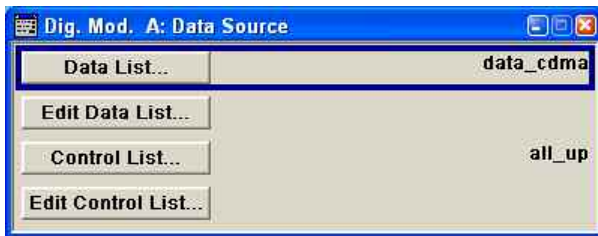

The data and control lists are selected and created in the **File Select** menu which is called up by means of the **Data List...** and **Control List...** buttons.



The **File Manager** is used to copy, rename and delete files and to create directories (see also Chapter 3, section "[File Management](#)")

To ensure that the selected data or control list is used for generating the digital signal, the list must be selected as the data source:

Data	Parameter	Selection
Digital data	Source:	DList
Marker	Marker Mode:	CList
Control signals CW, Level Attenuation and Burst Gate	Source	Internal

The data editor is called using the **Edit Data List...** and **Edit Control List...** buttons. The contents of the selected list are displayed. Operating the list editors is described in Chapter 3, section "[List Editors](#)".



**Select Data/Control List - Digital Modulation**

Selects data/control list. This opens the **File Select** window in which the data/control list can be selected.

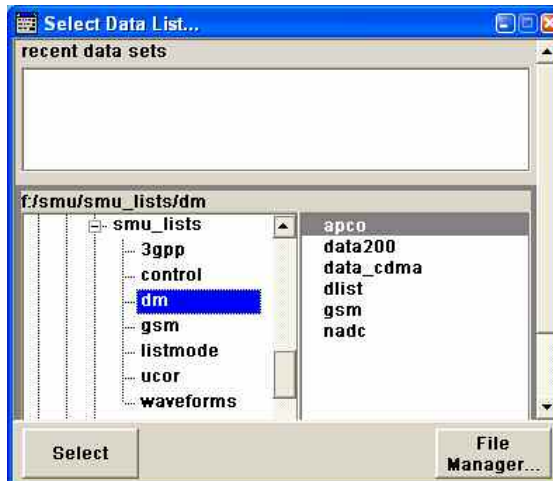

Remote-control commands:

SOUR:BB:DM:DLIS:SEL "d\_list1"

SOUR:BB:DM:CLIS:SEL "c\_list3"

**Create Data/Control List - Digital Modulation**

Creates new data/control list. This opens the **File Select** window in which the data/control list can be created.

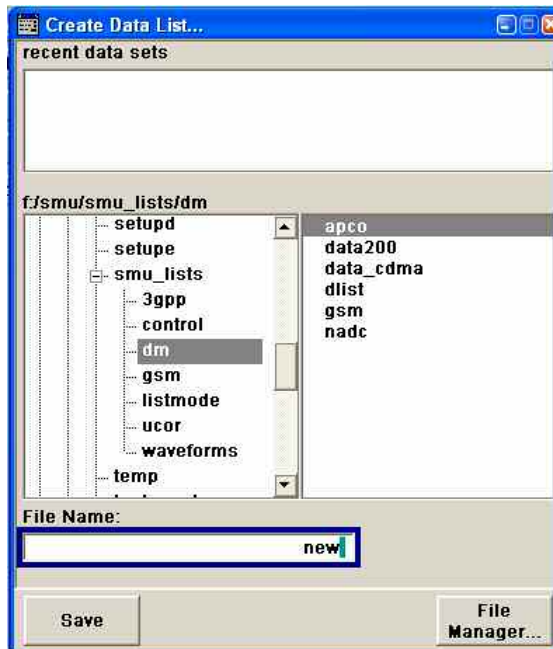

The file name has to be entered in field **File Name:**. The new list contains no data, it can be edited in the list editor.

Remote-control commands:

SOUR:BB:DM:DLIS:SEL "d\_list1"

SOUR:BB:DM:CLIS:SEL "c\_list3"

**File Manager - Digital Modulation**

Calls the **File Manager**.

The File Manager is used to copy, delete and rename files and to create new directories.



Remote-control commands:

```
SOUR:BB:DM:DLIS:SEL "d_list1"  
SOUR:BB:DM:DLIS:COPY "D_list2"  
SOUR:BB:DM:DLIS:DEL "c_list1"  
SOUR:BB:DM:CLIS:SEL "c_list3"  
SOUR:BB:DM:CLIS:COPY "c_list2"  
SOUR:BB:DM:CLIS:DEL "c_list1"  
MME:MDIR "D:\user\new"
```

## Data List Editor - Digital Modulation

The **Data List Editor** for editing the selected data list is called up in the **Data/Control List Management** submenu of the **Digital Modulation** main menu by means of the **Edit Data List...** button. Chapter 3, Section "*List Editor*" describes how to use the editor.

A list of binary values with a maximum length of 2<sup>31</sup> bits can be entered in the **Data Editor**. This value corresponds to a file size of approx. 268 Mbyte.

To increase readability, the bits are displayed in groups of four. The current cursor position, the length of the list and the list file name are displayed above the list. The offset starts with the value 0 which corresponds to the bit position on the left side of the first row, i.e. the beginning of the list. On the left edge of the editor, the last three offset positions are specified at the beginning of the row.

An existing list can be edited in the insert or overwrite mode.

Remote-control commands:

```
SOUR:BB:DM:DLIS:SEL "d_list1"
SOUR:BB:DM:DLIS:DATA 1,1,0,1,0,1,0,1,1,1,1,0,0,0
SOUR:BB:DM:DLIS:DATA:APP 1,1,0,1,0,1,0,1,1,1,1,0,0,0
```

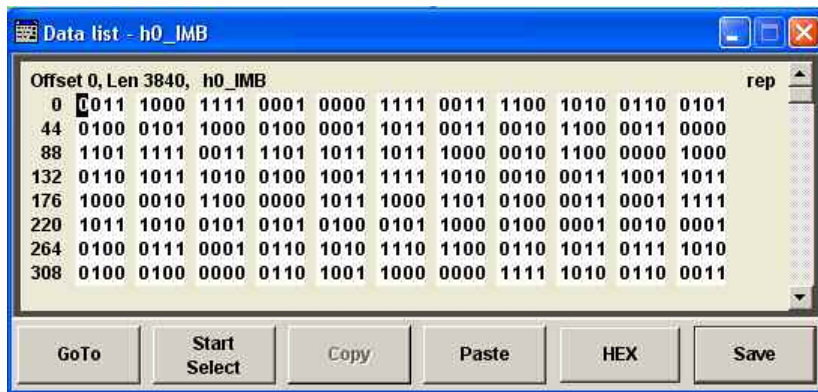

### GoTo - Digital Modulation

Opens the entry window for the bit position. The cursor marks the bit at the selected position.

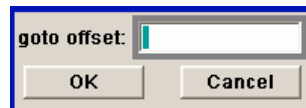

Remote-control command: n.a.

### Start Select - Digital Modulation

Defines the current cursor position as the start position for the range to be marked. The stop position is defined by entering an offset under **GoTo**.

When a start position has been activated, the button will be re-labelled to **Undo Select**. When the button is clicked now, the selected range will be deactivated.

Remote-control command: n.a.

**Copy - Digital Modulation** Copies the selected values.  
Remote-control command: n.a.

**Cut - Digital Modulation** Cuts the selected values.  
Remote-control command: n.a.

**Paste - Digital Modulation** Pastes the values that have been copied or cut before.  
Remote-control command: n.a.

**Hex - Digital Modulation** Switchover to hexadecimal display.

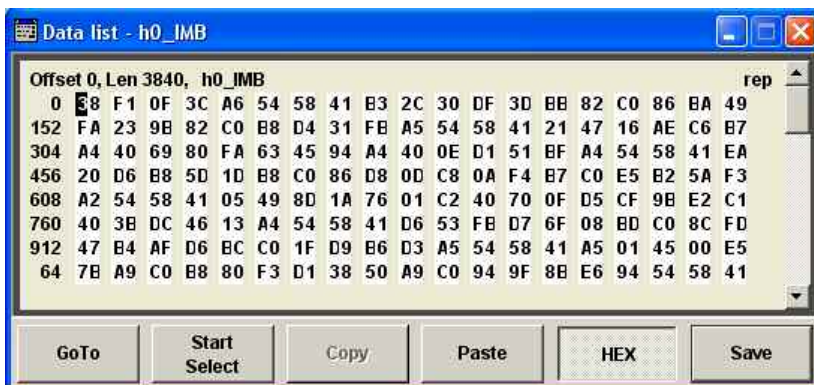

Each four bits are displayed as a hexadecimal value: To increase readability, the hexadecimal values in turn are displayed in pairs of two. The hex functions are automatically assigned to the numeric keys at the front panel.

Remote-control command: n.a.

**Save (Data List) - Digital Modulation** Saves the changes made to the Data List file selected for editing.

Remote-control command: n.a.

## Control and Marker List Editor - Digital Modulation

The **Control and Marker List Editor** for editing the selected control list is called up in the **Data/Control List Management** submenu of the **Digital Modulation** main menu by means of the **Edit Control List...** button.



The four available marker signals and the CW, Hop, Burst Gate and Level Attenuation control signals can be defined in the **Control and Marker List Editor**.

### Note:

*The marker signals defined in the Control and Marker List Editor are activated by selecting the Marker mode "**CList**" in the **Trigger/Marker/Clock menu**.*

*The control signals have to be activated by selecting an "**Internal**" Source in the respective setting menu, e.g. the **Power Ramp Control** menu for the Burst Gate and Level Attenuation control signals.*

The configuration of the currently selected control list is displayed. This list is either selected in the **File Select** menu (**Data/Control List Management** submenu by means of the **Control List...** button) or via

Remote-control commands:

```
SOUR:BB:DM:CLIS:SEL "c_list3"
SOUR:BB:DM:CLIS:DATA 0,8,8,8,8,8,8,0,0,0,...
```

The available marker/control signals are color-coded. In the left **Configure Control Signal** section, each individual signal is assigned a colour; a check in the check box shows the marker for which the "**CList**" marker type has been selected and the control signal for which the "**Internal**" source has been selected.

In the **Select Ramp to Edit** section the signal characteristics are graphically displayed. The scaling of the x-axis is always adapted to the overall length of the control list to provide constant overview of all defined ramps.

The ramps can be assigned the exact bit position in the signal by means of

- The bit scale below the marker/control signal characteristic.
- The display of the current cursor position in the **Cursor** menu section if the cursor marks the ramp.

The ramps can be set either graphically in the **Select Ramp to Edit** section or in the table of the **Positions <Signal>** section in the lower right corner. To make the setting easy, a selection of preset ramp characteristics is offered in the **Preset Ramp <Signal>** section.

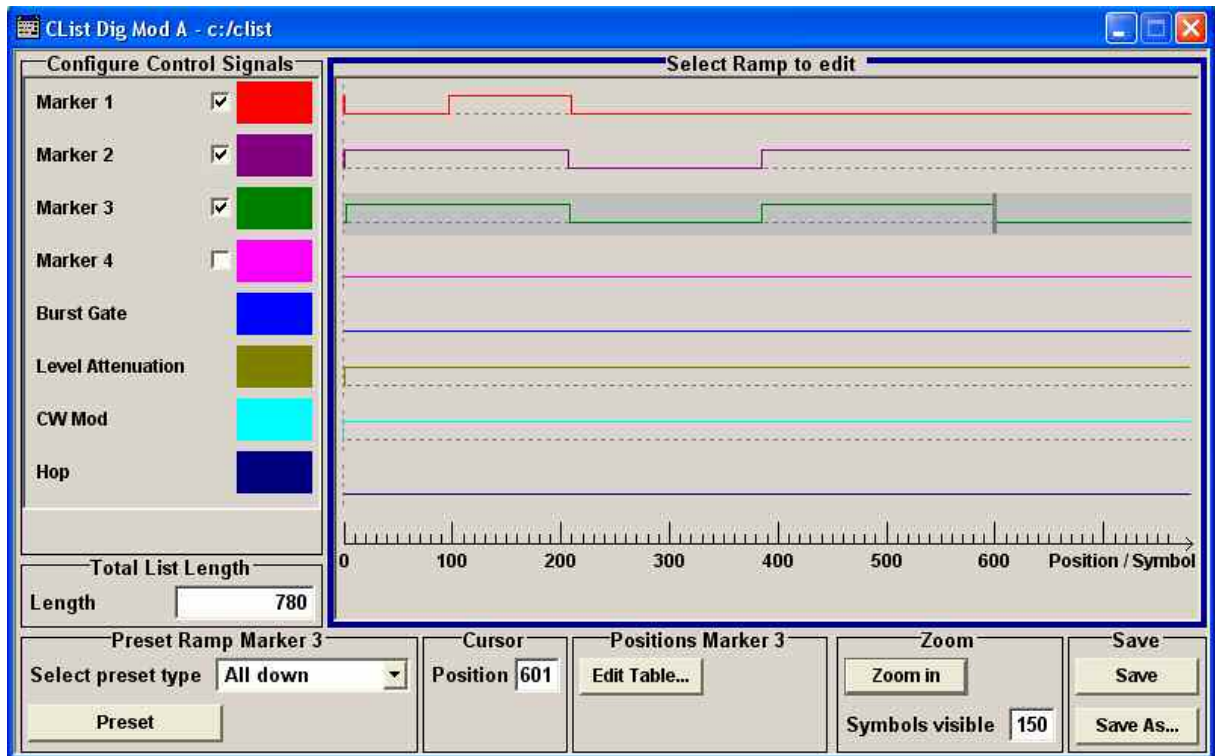

### Configure Control Signal - Digital Modulation

Displays the colour the marker/control signal has been assigned.

Displays whether the "CList" marker type has been selected in the Trigger/Marker/Clock menu for this marker.

Displays whether the "Internal" source has been selected for this control signal in the individual setting menu. Burst Gate and Level Attenuation are set in the **Power Ramping** submenu, CW in the **Modulation** submenu.

The source "CList/Internal" for the individual marker/control signal can be selected here as well and will then be used in the associated menus.

Remote-control command: n.a.

### Select Ramp to Edit - Digital Modulation

Graphically edit marker/control signals.

For this purpose, the cursor is set to the position where a ramp is required. The ramp is generated by pressing Enter (e.g. clicking on the rotary knob). Any number of ramps can be defined per marker. Each of the generated ramp positions will be saved even if the definition of another ramp produces a low/low or high/high transition. These ramps are displayed as dashed lines.

Existing ramps can be shifted after the cursor has been placed on the ramp and Enter has been pressed - it then changes colour twice. The ramp is shifted by using the cursor keys or the rotary knob. The new position is determined by pressing Enter again.

Ramps can be deleted by means of the `BACK-SPACE` key after the cursor has been placed on the ramp.

Chapter 3 describes how to operate the control and marker list editor in detail.

Remote-control command: n.a.

**Total List Length - Digital Modulation**

Enters the length of the definition range of the control list in bits. The starting value is always bit 0. The entire definition range is displayed, i.e. the bit scale is adapted to the entry.

With very long control lists, the displayed area can be zoomed to approx. 300 bits around the current cursor position (**Zoom in** button).

The preset functions set the ramp in the center of the currently selected area.

If the definition range is decreased, the ramps outside the range are lost.

When used, the control list is always repeated over the length of the definition range if the length of the data list exceeds the length of the control list.

Remote-control command: n.a.

**Preset Ramp - Digital Modulation**

Activates presetting for the ramp characteristic of the selected control signal. The presetting is selected with **Select Preset Type** and activated by means of the **Preset** button.

Remote-control command: n.a.

You can select from:

- |                     |                                                                                                                                                                                                                  |
|---------------------|------------------------------------------------------------------------------------------------------------------------------------------------------------------------------------------------------------------|
| <b>All Up</b>       | The marker/control signal is continuously high.                                                                                                                                                                  |
| <b>All Down</b>     | The marker/control signal is continuously low.                                                                                                                                                                   |
| <b>Ramp Up</b>      | The marker/control signal contains a ramp from low to high. The ramp is shifted to the center of the displayed signal area and can subsequently be shifted as required.                                          |
| <b>Ramp Down</b>    | The marker/control signal contains a ramp from high to low. The ramp is shifted to the center of the displayed signal area and can subsequently be shifted as required.                                          |
| <b>Ramp Up/Down</b> | The marker/control signal contains a ramp from low to high and from high to low. The ramps are symmetrically shifted around the center of the displayed signal area and can subsequently be shifted as required. |
| <b>Ramp Down/Up</b> | The marker/control signal contains a ramp from high to low and from low to high. The ramps are symmetrically shifted around the center of the displayed signal area and can subsequently be shifted as required. |

**Cursor Position - Digital Modulation**

Enters the cursor position.

In the graphic display, the cursor is positioned according to the entry.

Vice versa, graphically shifting the cursor will change the displayed value.

If the entered value exceeds the selected length of the definition range, the length is adjusted automatically.

Remote-control command: n.a.

**Positions Control Signal - Digital Modulation**

Opens table by using the **Edit Table ...** button.

The ramps of the selected signal can be edited in the table. When the table is opened, the current configuration of the selected marker/control signal is displayed.

	Ramp Positions	Ramp State
1	20	High
2	50	Low
3	66	High
4	71	Low
5	81	High
6	223	Low
7		Low

The bit position is specified in the **Ramp Position** column, the high or low signal status in the **Ramp State** column. At the end of the list, there is always a blank row for entering new values.

The changes are accepted in the graphic display after pressing the **Accept** button.

Remote-control command: n.a.

**Zoom - Digital Modulation**

Zooms the displayed area of the control list. The designation of the button changes from **Zoom in** to **Zoom out**.

With very long control lists, the displayed area can be zoomed to approx. 300 bits around the current cursor position.

Ramps outside the displayed area are not lost by zooming.

Parameter Symbols visible sets the symbols to be displayed.

Remote-control command: n.a.

**Save/Save As - Digital Modulation**

Pressing the **Save** button sves the changes made to the CList file selected for editing.

Selecting the **Save As** button creates a new control list.

This opens the **Create Lists Files Which Name?** window in which the control list can be created.

The file name has to be entered in field **File Name**.

Remote-control command: n.a.



## Power Ramp Control - Digital Modulation Menu

The Power Ramp Control menu is accessed via the **Digital Modulation** main menu.

The menu is used to set the power ramping. Control signals **Burst** and **Lev\_Att** are used to control power ramping (see also section "[Power Ramping and Level Attenuation](#)", page 4.193).

---

**Note:**

*Power ramping is possible up to a symbol rate of 5 MHz. If a higher symbol rate is set, power ramping is automatically switched off and an error message is output.*

---

**State - Power Ramp Control - Digital Modulation**

Enables/disables power ramping.

Remote-control command:

SOUR:BB:DM:PRAM:STAT ON

**Source - Power Ramp Control - Digital Modulation**

Enters the source for the power ramp control signals.

**Internal**

The control signals in the internal control list are used for control purposes.

The signals are output on the LEV\_ATT and BURST pin on the AUX I/O interface (in case of two-path instruments, path A).

In the case of two-path instruments, the path B signal can be placed on one of the USER interfaces.

Remote-control command:

SOUR:BB:DM:PRAM:SOUR INT

**External Digital**

The control signal is fed in via the AUX I/O interface.

For two-path instruments, path A = LEV-ATT pin, path B = user-definable USER pin or USER connector.

Remote-control command:

SOUR:BB:DM:PRAM:SOUR EXT

**Ramp Function - Digital Modulation**

Enters the form of the transmitted power, i.e. the shape of the rising and falling edges during power ramp control.

**Linear**

The transmitted power rises and falls linear fashion.

Remote-control command:

SOUR:BB:DM:PRAM:SHAP LIN

**Cosine**

The transmitted power rises and falls with a cosine-shaped edge. This gives rise to a more favorable spectrum than the **Linear** setting.

Remote-control command:

SOUR:BB:DM:PRAM:SHAP COS

<b>Ramp Time - Digital Modulation</b>	<p>Enters the power ramping rise time and fall time for a burst. The setting is expressed in symbols.</p> <p>Remote-control command: SOUR:BB:DM:PRAM:TIME 2.5</p>
<b>Rise Delay - Power Ramp Control - Digital Modulation</b>	<p>Sets the offset in the rising edge of the envelope at the start of a burst. A positive value gives rise to a delay (see figure, the envelope length decreases) and a negative value causes an advance (the envelope length increases). The setting is expressed in symbols.</p> <p>Remote-control command: SOUR:BB:DM:PRAM:RDEL -1</p>
<b>Fall Delay - Power Ramp Control - Digital Modulation</b>	<p>Sets the offset in the falling edge of the envelope at the end of a burst. A positive value gives rise to a delay (see figure, the envelope length increases) and a negative value causes an advance (the envelope length decreases). The setting is expressed in symbols.</p> <p>Remote-control command: SOUR:BB:DM:PRAM:FDEL -1</p>
<b>Attenuation - Power Ramp Control - Digital Modulation</b>	<p>Sets the level attenuation relative to the average level for the signal ranges in which the level is set to <b>attenuated</b> (LEV_ATT control signal).</p> <p>The LEV_ATT control signal is defined in the <b>Control Data Editor</b> or supplied via the LEV_ATT pin on the AUX I/O interface.</p> <p>In case of two-path instruments, the LEV_ATT control signal is supplied via the LEV_ATT pin for path A or via a user-defined USER pin for path B.</p> <p>Remote-control command: SOUR:BB:DM:PRAM:ATT 15 dB</p>
<b>Baseband Only - Power Ramp Control - Digital Modulation</b>	<p><b>(For SMx instruments only)</b></p> <p>Restricts power ramping to the baseband signal.</p>
<b>Off</b>	<p>Level attenuation is effected via the attenuator stages in the RF section; only the remaining part is attenuated in the baseband. The signal is issued at the RF output with the defined level values.</p> <p>Remote-control command: SOUR:BB:DM:PRAM:BBON OFF</p>
<b>On</b>	<p>Level attenuation is effected in the baseband only.</p> <p>This setting is mandatory in the following cases: When only the baseband signal is issued at the I/Q outputs. It is thus ensured that, with power ramping active, this signal is output with the defined level values.</p> <p>In case of two-path instruments, when a baseband signal is applied to two RF paths. The RF paths having separate frequency and level settings, the remaining attenuation to be effected in the baseband would have to be different for the two paths and is therefore not possible.</p> <p>Remote-control command: SOUR:BB:DM:PRAM:BBON ON</p>

## Trigger/Marker/Clock - Custom Digital Modulation Menu

The Trigger menu is accessed via the **Digital Modulation** main menu.



The Trigger In section is where the trigger for the modulation signal is set. Various parameters will be provided for the settings, depending on which trigger source - internal or external - is selected. The current status of signal generation (Running or Stopped) is indicated for all trigger modes.



The Reconfigure Marker section is where the marker signals at the MARKER output connectors are configured.

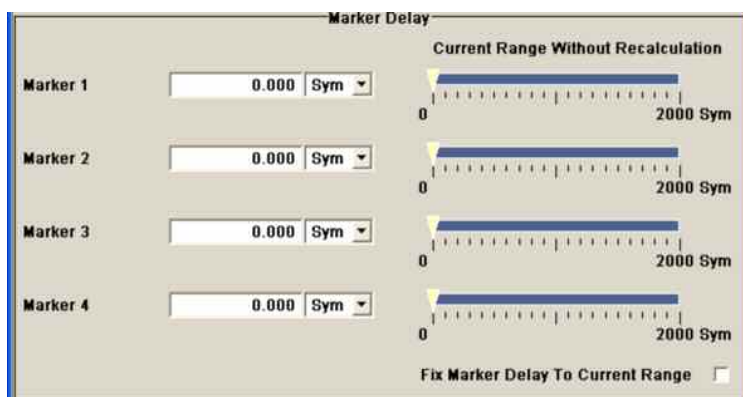

The Marker Delay section is where a marker signal delay can be defined, either without restriction or restricted to the dynamic section, i.e. the section in which it is possible to make settings without restarting signal and marker generation.



The Clock Settings section is where the clock source is selected and - in the case of an external source - the clock type.

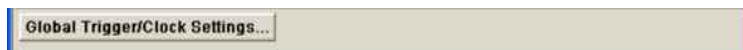

The Global Trigger/Clock Settings button leads to a submenu for general trigger, clock and external input settings.

The **Trigger In** section is used to configure the trigger signal for the digital modulation. The current status of signal generation is indicated for all trigger modes.

### Trigger Mode - Digital Modulation

Selects trigger mode.

<b>Auto</b>	<p>The digital modulation signal is generated continuously.</p> <p>Remote-control command: SOUR:BB:DM:SEQ AUTO</p>
<b>Retrigger</b>	<p>The digital modulation signal is generated continuously. A trigger event (internal with <b>Execute Trigger</b> or external) causes a restart.</p> <p>Remote-control command: SOUR:BB:DM:SEQ RETR</p>
<b>Armed_Auto</b>	<p>The digital modulation signal is generated only when a trigger event occurs. Then the digital modulation signal is generated continuously.</p> <p>Button <b>Arm</b> stops signal generation. A subsequent trigger event (internal with <b>Execute Trigger</b> or external) causes a restart.</p> <p>Remote-control command: SOUR:BB:DM:SEQ AAUT</p>
<b>Armed_Retrigger</b>	<p>The digital modulation signal is generated only when a trigger event occurs. Then the signal is generated continuously. Every subsequent trigger event (internal with <b>Execute Trigger</b> or external) causes a restart.</p> <p>The button <b>Arm</b> stops signal generation. A subsequent trigger event (internal with <b>Execute Trigger</b> or external) causes a restart.</p> <p>Remote-control command: SOUR:BB:DM:SEQ ARET</p>
<b>Single</b>	<p>The digital modulation signal is generated only when a trigger event occurs. Then the signal is generated once to the length specified at <b>Signal Duration</b>. Every subsequent trigger event (internal with <b>Execute Trigger</b> or external) causes a restart.</p> <p>Remote-control command: SOUR:BB:DM:SEQ SING</p>

### Trigger Signal Duration - Digital Modulation

Enters the length of the signal sequence to be output in the **Single** trigger mode. The input is to be expressed in symbols.

Remote-control commands:  
SOUR:BB:DM:TRIG:SLEN 200

<b>Running - Stopped - Digital Modulation</b>	<p>Displays the status of signal generation for all trigger modes. This display appears only when Custom Dig Mod is enabled (<b>State On</b>).</p> <p>Remote-control command:  <code>SOUR:BB:DM:TRIG:RMOD?</code>                  Response: <code>RUN</code> or <code>STOP</code></p> <p><b>Running</b>            The digital modulation signal is generated; a trigger was (internally or externally) initiated in triggered mode.</p> <p style="padding-left: 100px;">If <code>Armed_Auto</code> and <code>Armed_Retrigger</code> have been selected, generation of signals can be stopped with the <b>Arm</b> button. A new trigger (internally with <b>Execute Trigger</b> or externally) causes a restart.</p> <p><b>Stopped</b>            The signal is not generated, and the instrument waits for a trigger event (internal or external).</p>
<b>Arm - Digital Modulation</b>	<p>Stops signal generation. This button appears only with <b>Running</b> signal generation in the <b>Armed_Auto</b> and <b>Armed_Retrigger</b> trigger modes.</p> <p>Signal generation can be restarted by a new trigger (internally with <b>Execute Trigger</b> or externally).</p> <p>Remote-control command:  <code>SOUR:BB:DM:TRIG:ARM:EXEC</code></p>
<b>Execute Trigger - Digital Modulation</b>	<p>Executes trigger manually. A manual trigger can be executed only when an internal trigger source and a trigger mode other than <b>Auto</b> have been selected.</p> <p>Remote-control commands:  <code>SOUR:BB:DM:TRIG:SOUR INT</code>  <code>SOUR:BB:DM:SEQ RETR</code>  <code>SOUR:BB:DM:TRIG:EXEC</code></p>
<b>Trigger Source - Digital Modulation</b>	<p>Selects trigger source.</p> <p><b>Internal</b>            The trigger event is executed by <b>Execute Trigger</b>. As a precondition a trigger mode other than <b>Auto</b> must be selected.</p> <p style="padding-left: 100px;">Remote-control command:  <code>SOUR:BB:DM:TRIG:SOUR INT</code></p> <p><b>Internal (Baseband A/B)</b>    The trigger event is executed by the trigger signal from the second path (two-path instruments only).</p> <p style="padding-left: 100px;">Remote-control command:  <code>SOUR:BB:DM:TRIG:SOUR OBAS</code></p> <p><b>External (TRIGGER 1/2)</b>    The trigger event is executed with the aid of the active edge of an external trigger signal. The trigger signal is supplied via the TRIGGER 1 or TRIGGER 2 connector.</p> <p style="padding-left: 100px;">The polarity, the trigger threshold and the input impedance of the TRIGGER input can be set in the <b>Global Trigger Settings</b> menu.</p> <p style="padding-left: 100px;">Remote-control command:  <code>SOUR:BB:DM:TRIG:SOUR BEXT</code></p>

**Trigger Delay - Digital Modulation**

Sets trigger signal delay in symbols on external triggering or, in case of two-path instruments, on internal triggering via the second path.

This enables the R&S Signal Generator to be synchronized with the device under test or other external devices.

**Note:**

*For two path instruments, the delay can be set separately for each of the two paths.*

Remote-control command:

```
SOUR:BB:DM:TRIG:EXT:DEL 3
SOUR:BB:DM:TRIG:OBAS:DEL 3
```

**Trigger Inhibit - Digital Modulation**

Sets the duration for inhibiting a new trigger event subsequent to triggering. The input is to be expressed in symbols.

In the **Retrigger** mode every trigger signal causes signal generation to restart. This restart is inhibited for the specified number of samples.

This parameter is only available on external triggering or, in case of two-path instruments, on internal triggering via the second path.

**Note:**

*For two-path instruments, the trigger inhibit can be set separately for each of the two paths.*

Remote-control command:

```
SOUR:BB:DM:TRIG:EXT:INH 0
SOUR:BB:DM:TRIG:OBAS:INH 0
```

The marker output signal for synchronizing external instruments is configured in the **Marker Settings** section **Reconfigure Marker**.

**Marker x - Digital Modulation**

Selects a marker signal for the associated MARKER output.

**CList**

A marker signal that is defined in the selected control list is generated.

Remote-control commands:

```
SOUR:BB:DM:TRIG:OUTP1:MODE CLIS
SOUR:BB:DM:CLIS:SEL 'control_dm'
```

**Pulse**

A regular marker signal is generated. The clock frequency is defined by entering a divider. The frequency is derived by dividing the sample rate by the divider. The input box for the divider opens when **Pulse** is selected, and the resulting pulse frequency is displayed below it.

Divider	<input type="text" value="8.00"/>
Frequency	33.854 17 kHz

Remote-control commands:

```
SOUR:BB:DM:TRIG:OUTP1:MODE PULS
SOUR:BB:DM:TRIG:OUTP1:PULS:DIV 4
SOUR:BB:DM:TRIG:OUTP1:PULS:FREQ?
```

**Pattern**

A marker signal that is defined by a bit pattern is generated. The pattern has a maximum length of 32 bits and is defined in an input field which opens when **pattern** is selected.

Remote-control commands:

```
SOUR:BB:DM:TRIG:OUTP1:MODE PATT
SOUR:BB:DM:TRIG:OUTP1:PATT #B1111,4
```

**ON/OFF ratio**

A regular marker signal that is defined by an ON/OFF ratio is generated. A period lasts one ON and OFF cycle.

Start of signal

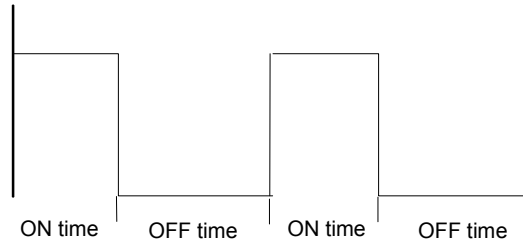

The ON time and OFF time are each expressed as a number of symbols and are set in an input field which opens when **ON/OFF ratio** is selected.

On Time  Sym   
 Off Time  Sym

Remote-control commands:

```
SOUR:BB:DM:TRIG:OUTP1:MODE RAT
SOUR:BB:DM:TRIG:OUTP1:OFFT 20
SOUR:BB:DM:TRIG:OUTP1:ONT 20
```

The **Marker Delay** section can be used to set a delay for the markers.

**Marker x Delay - Digital Modulation**

Enters the delay between the marker signal at the marker outputs and the start of the signal.

The input is expressed as a number of symbols.

If the setting "**Fix marker delay to dynamic range**" is enabled, the setting range is restricted to the dynamic range. In this range the delay of the marker signals can be set without restarting the marker and signal.

The allocation of marker signals to the outputs is described in the section "[Marker Output Signals](#)", page 4.195.

Remote-control command:

```
SOUR:BB:DM:TRIG:OUTP2:DEL 20
```

**Current Range without Recalculation - Digital Modulation**

Displays the dynamic range within which the delay of the marker signals can be set without restarting the marker and signal.

The delay can be defined by moving the setting mark.

Remote-control command:

SOUR:BB:DM:TRIG:OUTP:DEL:MAX?

SOUR:BB:DM:TRIG:OUTP:DEL:MIN?

**Fix marker delay to current range - Digital Modulation**

Restricts the marker delay setting range to the dynamic range. In this range the delay can be set without restarting the marker and signal.

Remote-control command:

SOUR:BB:DM:TRIG:OUTP:DEL:FIX ON

The clock source is selected in the **Clock Settings** section.

**Clock Source - Digital Modulation**

Selects the clock source (also see section "[Clock Signals](#)", page 4.189).

**Internal**

The internal clock reference is used.

Remote-control command:

SOUR:BB:DM:CLOC:SOUR INT

**External**

The external clock reference is fed in as the symbol clock or a multiple thereof via the CLOCK connector.

The chip rate must be correctly set to an accuracy of  $\pm 2\%$  (see data sheet).

The polarity of the clock input can be changed with the aid of **Global Trigger/Clock/External Input Settings**.

In the case of two-path instruments, this selection applies to path A.

Remote-control command:

SOUR:BB:DM:CLOC:SOUR EXT

**Clock Mode - Digital Modulation**

Enters the type of externally supplied clock.

**Symbol**

A symbol clock is supplied via the CLOCK connector.

Remote-control command:

SOUR:BB:DM:CLOC:MODE SYMB



**Multiple Symbol** A multiple of the symbol clock is supplied via the CLOCK connector, the symbol clock is derived internally from this.

The **Multiplier** window provided allows the multiplication factor to be entered.

---

**Note:**

*This setting is not possible if the serial or parallel external data source is selected.*

---

Remote-control command:

SOUR:BB:DM:CLOC:MODE MSYM

SOUR:BB:DM:CLOC:MULT 4

**Bit** A bit clock is supplied via the CLOCK connector; the symbol clock is derived internally from this.

---

**Note:**

*This setting is not possible if the serial or parallel external data source is selected.*

---

Remote-control command:

SOUR:BB:DM:CLOC:MODE BIT

**Symbol Clock Multiplier - Digital Modulation**

Enters the multiplication factor for clock type **Multiple**.

Remote-control command:

SOUR:BB:DM:CLOC:MULT 4

**Measured External Clock - Digital Modulation**

Displays the measured frequency of the external clock signal. This enables the user to permanently monitor the frequency of the externally introduced clock.

This information is displayed only if the external clock source has been selected.

Remote-control command:

CLOC:INP:FREQ?

**Global Trigger/Clock/Input Settings - Digital Modulation**

Calls the **Global Trigger/Clock/Input Settings** menu. This menu is used among other things for setting the trigger threshold, the input impedance and the polarity of the clock and trigger inputs. In the case of two-path instruments, these settings are valid for both paths. The parameters in this menu affect all digital modulations and standards, and are described in the section "[Global Trigger/Clock/Input Settings - Setup - Environment](#)".

# Arbitrary Waveform Generator ARB

## Introduction – ARB

---

**Note:**

*The Arbitrary Waveform Generator is not part of the signal generation software WinIQSIM2. However, WinIQSIM2 allows to create multi carrier and multi segment waveform files, see section "Create Multi Segment Waveforms - ARB Menu", page 4.257 and "Create Multi Carrier Waveforms - ARB Menu", page 4.263.*

---

The Arbitrary Waveform Generator is an I/Q modulation source forming an integral part of the R&S Signal Generator. It can be used to output any externally calculated modulation signals or internally generated multi carrier signals.

The Arbitrary Waveform Generator is incorporated in the Baseband Generator (B9/B10/B11) option. The Baseband Main Module (B13) option is also required. The three Baseband Generator options feature different ARB memory sizes (see data sheet). Apart from the memory size, however, the three options offer the same functionality, either one can be installed.

In the case of two-path instruments, at least one further Baseband Generator option is needed for waveform output in the second path. Using this option a waveform can be read in on path B and then either routed via path A or added to the signal on path A with a frequency offset that can be set.

Waveform files can be loaded into the instrument via one of the computer interfaces (USB - memory stick, or Ethernet interface - network drive) or via the IEC bus.



A Windows software package **WinIQSIM2** is available for generating external waveform files on a PC.

It is included among the items and services supplied with the Baseband Generator (B9/B10/B11) option. With effect from version 4.10 and higher, this software defines waveforms in a format which fully exploits the extended functionality of the R&S Signal Generator (e.g. 16-bit resolution, extended memory capacity).

It is also possible to transfer signals that have been calculated using a mathematical program such as Matlab (see also Application Note 1MA28, IQWizard - I/Q Signal Measurement and Conversion, which can be obtained by visiting the Rohde&Schwarz web site at <http://www.rohde-schwarz.com>).

The R&S Signal Generator can actually generate ARB waveforms internally. These files are created and saved in the **ARB** menu.

It is possible to use either predefined or subsequently defined markers that are sent to the marker outputs in synchronicity with the I/Q output signals. The markers have to be selected in the menu and a delay can be selected by the user (see "Trigger/Marker/Clock - ARB MOD Menu", page 4.248).

Multi segment waveforms consisting of a combination of multiple waveforms can be defined in order to enable rapid alternation between different waveforms with differing test signals. Such waveforms can be used in test systems, for example. Each segment represents a completely independent waveform that is output with its own marker and clock settings. The entire multi segment waveform is loaded into memory. The segment intended to be output at any given moment can be selected by the user. It is therefore possible to alternate between the individual waveform segments without experiencing any delay due to the loading operation.

If very high switchover speeds are required, the test signals can be continuously scrolled through with the aid of an external trigger. For this purpose the segments must have a common sample rate. If the combined waveforms have different sample rates, they can be adapted to a common sample rate by resampling. By the same procedure the instantaneous amplitude of the various waveforms can be scaled to a common rms level.

Typical applications for the multi segment mode are described in the section "[Typical Applications for Multi Segment Waveforms - ARB Menu](#)", page 4.262.

Multi carrier waveforms consisting of up to 32 carriers modulated by user-selectable baseband signals can be created in order to simulate complex multi carrier scenarios with different baseband signals (e.g. CDMA2000 or 3GPP FDD).

The ARB has been produced in the form of an interpolating ARB generator. The resampler operates in such a way that a modulation signal with a sample rate of less than 100 MHz is interpolated on the 100-MHz sample rate and then used as output.

The sample rate must satisfy the following condition:

$$\text{Sample rate} \times 0.31 \geq \text{modulation bandwidth}$$

In the case of digital modulation: Sample rate = symbol rate (or chip rate) x oversampling

The value for the necessary oversampling is then calculated as follows:

$$\text{Oversampling} \geq \frac{\text{modulation bandwidth}}{\text{symbol (chip)rate} \times 0.31}$$

**Example:**

For the WCDMA digital standard with baseband filter  $\sqrt{\cos}$ ,  $\alpha = 0.22$  the following value is therefore calculated for the necessary oversampling:

$$\text{Modulation bandwidth} = \frac{(1 + \alpha)}{2} = 0.61, \text{Oversampling} \geq \frac{0.61}{0.31} = 1.97.$$

A modulation signal with a sample rate of exactly 100 MHz is passed directly to the Analog/Digital converter. The bandwidth is limited to 40 MHz by the lowpass filter only.

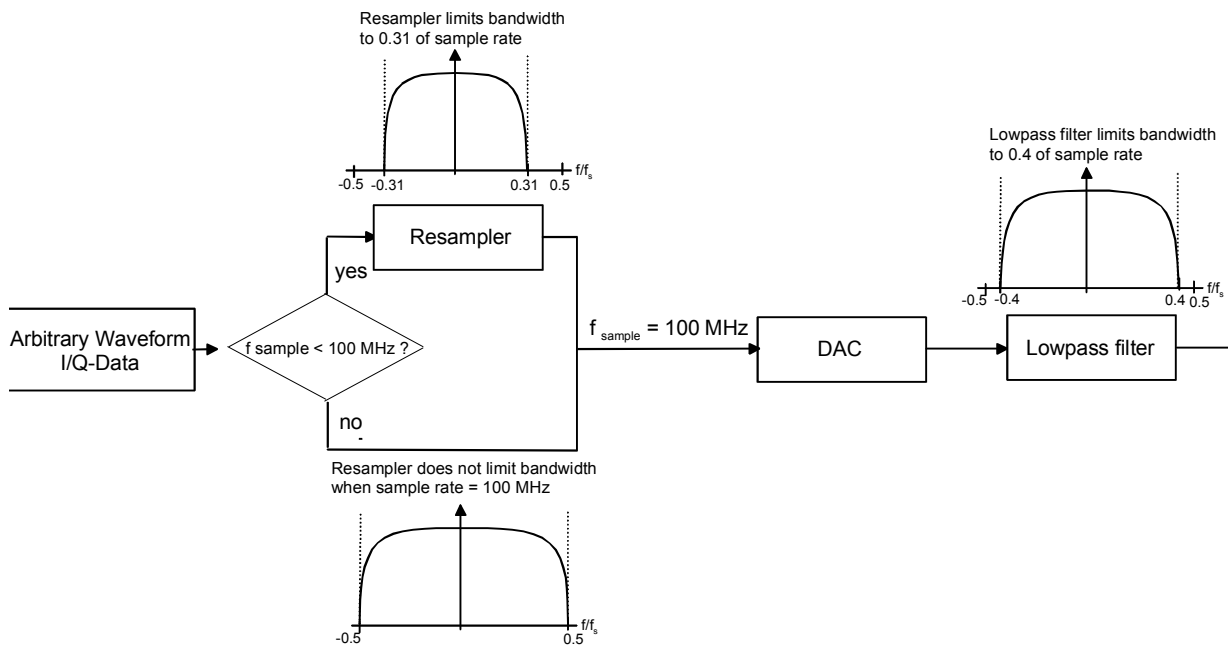

The reduced oversampling means that the signal duration is increased when the number of sample values is constant. Accordingly it is the case that when the duration is constant there is a reduction in the required number of sample values. In conventional ARB generators the minimum oversampling is normally held at 4. It therefore follows that with the above WCDMA system parameters and oversampling of 4 for the generation of a waveform with 10 frames (38 400 chips each) 1.5 Msamples are needed. The same waveform needs 740 ksamples in the R&S Signal Generator due to the lower oversampling of 1.97.

Modulation signals generated with the aid of the **WinIQSIM2** software can be optimized by selecting whole number oversampling or by defining a target sample rate, with the aim of achieving optimum exploitation of the maximum possible useful bandwidth, reducing the length of the waveform or obtaining the most extensive possible useful signal in the memory, according to need. Thus at the default target sample rate of 100 MHz, the maximum bandwidth of 40 MHz is available (see above, Signals with a sample rate of exactly 100 MHz).

Modulation signals can be generated without marker signals, whenever the marker functionality can be directly provided by the R&S Signal Generator, thus increasing the maximum waveform length.

The resolution for the I/Q data is 16 bits (16 bits I, 16 bits Q) and there are 4 bits available for the markers. I/Q data and marker data are located in separate memory areas of the SDRAM and can be independently configured (for example the same output clock but different periods).

A memory size of 256 MB (B10) yields a maximum waveform length of 56 MSamples (36 bits for I,Q and 4 markers = 4.5 bytes;  $256/4.5 \approx 56$  MSamples). The maximum waveform length increases to 64 MSamples if the internal hardware markers are used, in this case the complete memory is available for I/Q data (B11 = 16 MSamples).

The minimum length of a waveform is 512 samples. If a waveform is shorter than this, it is automatically repeated until it reaches the minimum length.

# ARB Menu

**Note:**

The Arbitrary Waveform Generator is available for R&S SMx and R&S AMU instruments and is not part of the signal generation software WinIQSIM2.

The menu for setting the ARB can be opened either in the **Baseband** block or by using the MENU key under **Baseband**.

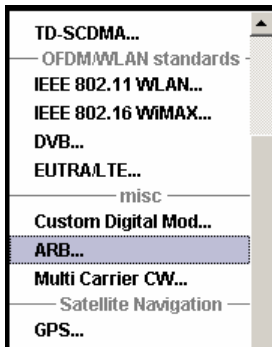

The **ARB** menu is divided into an upper and a lower general part together with a **Marker** section.

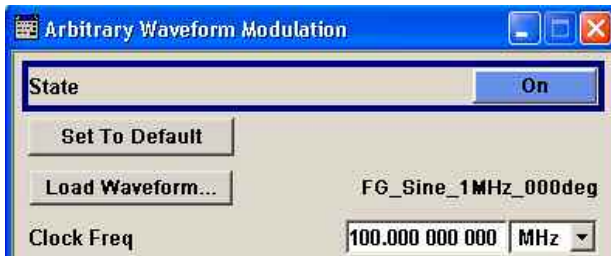

The upper part of the menu is used for powering up, selecting and configuring ARB modulation.

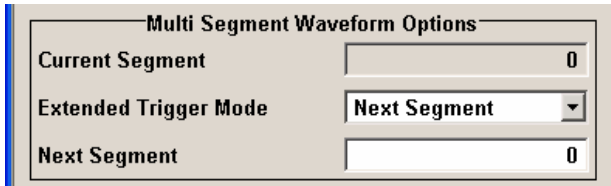

The section **Multi Segment Waveform Options** is only indicated if a multi segment waveform is loaded. In this part, the segment to be output is selected.



The buttons in the lower part of the menu open submenus for setting triggers and clocks, for configuring a sinusoidal test signal and for calculating a multi segment waveform or a multi carrier waveform.

## ARB MOD Main Menu

The upper part of the menu is used for powering up, selecting and configuring ARB modulation.

### State - ARB

Enables/disables ARB modulation.

Switching on this standard turns off all the other digital standards and digital modulation types (in case of two-path instruments, this affects the same path).

The output is based on the waveform file that is loaded. The name of the waveform file is displayed next to **Load Waveform**.

If a multi segment waveform is loaded the section **Multi Segment Waveform Options** is indicated. In this section, the segment to be output is selected.

If no waveform file is loaded, ARB modulation cannot be powered up. **None** will be displayed next to **Load Waveform**. An error message asks the user to load a waveform file:

**No waveform file loaded. ARB MOD state remains off. Please select a waveform file to load, before switching ARB MOD state on.**

Remote-control command:

SOUR:BB:ARB:STAT ON

### Set To Default - ARB

Calls default settings. The values are shown in the following table.

Remote-control commands:

SOUR:BB:ARB:PRES

Parameter	Value
State	Off
Trigger	
Mode	Auto
Source	Internal
Ext. Delay	0
Ext. Inhibit	0
Trigger Signal	
Mode	Auto
Source	Internal
External Delay	0
Inhibit	0
Marker Signal	
State	Off
CH. 1 Mode	Restart
CH. 2 Mode	Restart
CH. 3 Mode	Restart
CH. 4 Mode	Restart
Shift in Samples	0
Pulse Frequency	1 kHz
Pattern	'0'
ON/OFF ratio	1.1

Parameter	Value
Clock	
Frequency	1 MHz
Source	Intern
Delay	0
Sine Signal	
Frequency	1 kHz
Samples per Period	100
Phase Offset	90 DEG

**Load Waveform - ARB**

Calls the **File Select** menu for loading the waveform file.

The files last used are listed in the **Recent Data Sets** section. The directory can be selected from the center left section. All waveform files (file extension \*.vv) available from the selected directory are listed on the right side. The file info (tag contents and multi segment state) for the selected file is displayed below the file section.

The **Select...** button selects the marked file. This file is loaded when the ARB modulation is enabled (**State On**).

The **File Manager...** button leads to the file manager (see chapter 3).

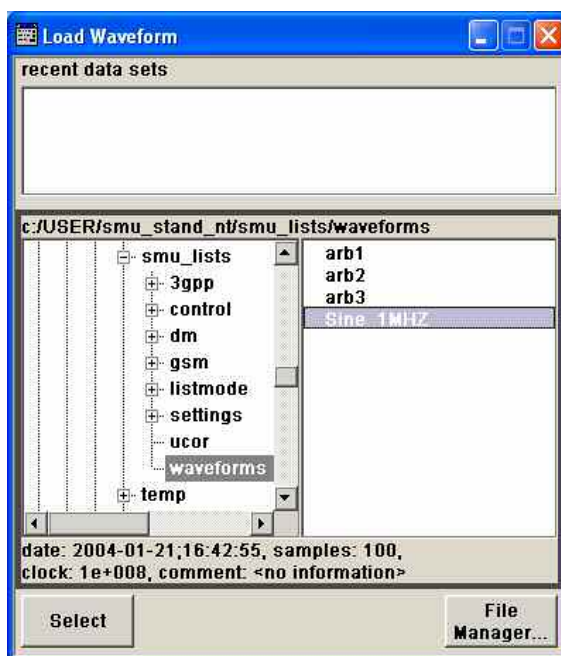

Remote-control command:

Example for a file in the default directory:

SOUR:BB:ARB:WAV:SEL 'Wave1'

Example for a file in a different directory:

SOUR:BB:ARB:WAV:SEL 'd:\user\wave\Wave1.vv'

**Clock Frequency - ARB**

Displays or enters the ARB output clock rate.

When the waveform file is loaded, this value is automatically set to the clock rate defined in the file (Clock tag). The user can subsequently alter the value if necessary.

When intending to work with an external clock source, the frequency to be applied must be entered here.

Remote-control command:

SOUR:BB:ARB:CLOC 10 MHz

The section **Multi Segment Waveform Options** of the menu is only displayed if a multi segment waveform is loaded.

**Current Segment - ARB**

Indication of the waveform segment that is currently output.

Remote-control command:

SOUR:BB:ARB:WSEG?

**Extended Trigger Mode - Multi Waveform ARB**

Sets the extended trigger mode in the case of a multi segment waveform.. Extended trigger mode defines how the switch between segments will take place:

When **Same Segment** and **Next Segment** are selected, the current segment ceases to be output as soon as a new segment is entered in **Next Segment**, and the new segment starts to be output after a system-imposed signal gap.

The following figure shows an example of the transition from a sinewave signal segment to a sawtooth segment (I channel, above) in the case of external triggering (below).

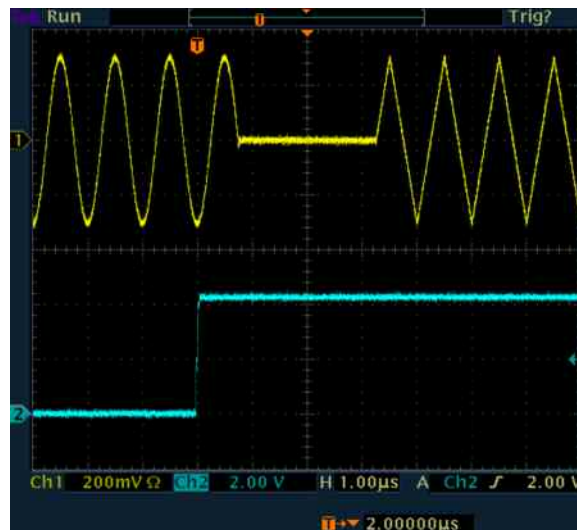

When **Next Segment Seamless** is selected and a new segment is entered in **Next Segment**, the new segment is not output until the whole of the current segment has been output (wrap around). In this case the signal transition is seamless (see **Next Segment Seamless**). A seamless switchover is only possible in the case of segments that have the same sample rate.



The following figure shows an example of the seamless transition from a sinewave signal segment to a sawtooth segment (I channel, above) in the case of external triggering (below).

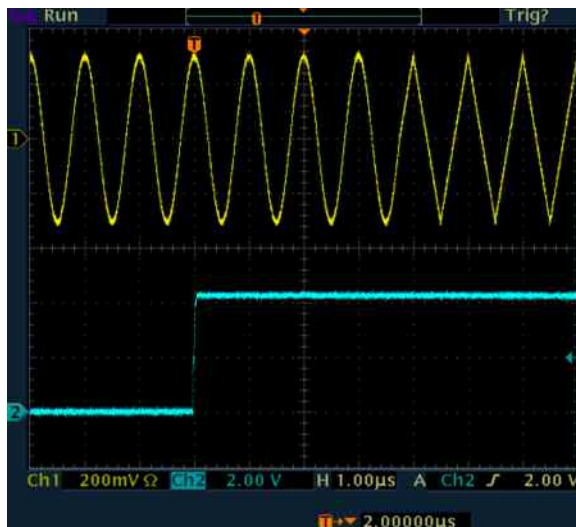

Extended trigger mode also defines the sequence in which segments will be output:

When **Internal Trigger Source** is selected it is possible to switch to any other segment by changing the entry in **Next Segment**. By selecting **Extended Trigger Mode** it is possible to define whether the new segment is generated immediately or only after the previous segment has been fully generated (wrap around).

Likewise when **External Trigger Source** is selected it is possible to switch to any other segment by changing the entry in **Next Segment**. It is also possible to scroll sequentially to the next available segment in the waveform by activating a trigger. The segment currently being output is displayed at **Current Segment**. The next trigger event after the last segment causes the first segment to be output again. By selecting **Extended Trigger Mode** it is possible to define whether the new segment is generated immediately or only after the previous segment has been fully output (wrap around).

When a multi segment waveform is loaded, generation of the signal starts at the segment defined in **Next Segment**.

The trigger settings in the **Trigger, Marker, Clock** submenu are similarly active. The possible combinations for the two trigger modes are specified in detail in the parameter description below.

**Same Segment** Depending on the trigger setting, the currently selected segment is continuously output either immediately or after a trigger event.

Signal generation takes place differently according to the trigger selected in the Trigger menu:

In the case of **Trigger = Auto**, output starts at once and the segment is generated continuously. Trigger events are ignored.

If the segment is changed in **Next Segment**, output of the current segment is stopped and the new segment is output immediately, following a system-imposed signal gap (see above).

In the case of **Trigger = Armed\_Auto**, output starts after the first trigger event. The segment is then generated continuously. Further trigger events are ignored.

If the segment is changed in **Next Segment**, signal output is stopped and the new segment is not output until a trigger occurs.

In the case of **Trigger = Retrigger**, output starts at once and the segment is generated continuously, a trigger event causes a restart.

If the segment is changed in **Next Segment**, output of the current segment is stopped and the new segment is output immediately, following a system-imposed signal gap (see above).

In the case of **Trigger = Armed\_Retrigger**, output starts after the first trigger event. The segment is then generated continuously. Further trigger events cause a restart.

If the segment is changed in **Next Segment**, signal output is stopped and the new segment is not output until a trigger occurs.

In the case of **Trigger = Single**, output starts after the first trigger event. The segment is then generated once. Further trigger events cause a restart.

If the segment is changed in **Next Segment**, signal output is not stopped. The new segment is not output until a trigger occurs.

Remote-control command:  
SOUR:BB:ARB:TRIG:SMOD SAME

**Next Segment** Depending on the trigger setting, the segment selected under **Next Segment** is output either immediately or after a trigger event.

In the case of **internal Trigger = Auto**, output starts at once and the segment is generated continuously. Trigger events are ignored.

If the segment is changed in **Next Segment**, output of the current segment is stopped and the new segment is output immediately, following a system-imposed signal gap (see above).

In the case of **internal Trigger = Armed\_Auto**, output starts after the first trigger event. The segment is then generated continuously. Further trigger events are ignored.

If the segment is changed in **Next Segment**, signal output is stopped and the new segment is not output until a trigger occurs.

In the case of **internal Trigger = Single**, output starts after the first trigger event. The segment is then generated once. Further trigger events cause a restart.

If the segment is changed in **Next Segment**, signal output is not stopped. The new segment is not output until a trigger occurs.

In the case of **External Trigger = Auto**, output starts at once and the segment is generated continuously. Each trigger event switches over to outputting the next segment. In this case there is a system-imposed signal gap (see above). The segment currently being output is displayed at **Current Segment**. The next trigger event after the last segment causes the first segment to be output again.

If the segment is changed in **Next Segment**, output of the current segment is stopped and the new segment is output immediately, following a system-imposed signal gap (see above).

In the case of **External Trigger = Armed\_Auto**, output starts after the first trigger event. The segment is then generated continuously. Each trigger event switches over to outputting the next segment. In this case there is a system-imposed signal gap (see above). The segment currently being output is displayed at **Current Segment**. The next trigger event after the last segment causes the first segment to be output again.

If the segment is changed in **Next Segment**, signal output is stopped and the new segment is not output until a trigger occurs.

In the case of **External Trigger = Single**, output starts after the first trigger event. The segment is then generated once. Each trigger event switches over to outputting the next segment once. The segment currently being output is displayed at **Current Segment**. The next trigger event after the last segment causes the first segment to be output again.

If the segment is changed in **Next Segment**, signal output is not stopped. The new segment is not output until a trigger occurs.

The remaining trigger modes (**Retrigger** and **Armed\_Retrigger**) are not available.

Remote-control command:

```
SOUR:BB:ARB:TRIG:SMOD NEXT
```

### Next Segment Seamless

The segment selected under **Next Segment** is output.

This mode is only available if all segments have the same sample rate.

In the case of **Internal Trigger = Auto**, output starts at once and the segment is generated continuously. Trigger events are ignored.

If the segment is changed in **Next Segment**, the new segment is output seamlessly after the output of the current segment is complete.

In the case of **internal Trigger = Armed\_Auto**, output starts after the first trigger event. The segment is then generated continuously. Further trigger events are ignored.

If the segment is changed in **Next Segment**, signal output is stopped and the new segment is not output until a trigger occurs.

In the case of **External Trigger = Auto**, output starts at once and the segment is generated continuously.

Each trigger event switches over to outputting the next segment once the output of the current segment has been completed. In each case segment currently being output is displayed at **Current Segment**. The next trigger event after the last segment causes the first segment to be output again.

If the segment is changed in **Next Segment**, the new segment is output seamlessly after the output of the current segment is complete.

In the case of **External Trigger = Armed\_Auto**, output starts after the first trigger event. The segment is then generated continuously. Each trigger event switches over to outputting the next segment once the output of the current segment has been completed. The segment currently being output is displayed at **Current Segment**. The next trigger event after the last segment causes the first segment to be output again.

If the segment is changed in **Next Segment**, signal output is stopped and the new segment is not output until a trigger occurs.

The remaining trigger modes (**Retrigger**, **Armed\_Retrigger** and **Single**) are not available.

Remote-control command:

```
SOUR:BB:ARB:TRIG:SMOD NSE
```

### Next Segment - ARB

Selects the waveform segment to be output next. It determines the start segment when switching on the ARB.

For an **internal trigger source**, switchover to any segment is performed by changing the entry at **Next Segment**. Depending on the selected **Extended Trigger Mode** the new segment is output either at once or only after the complete output (wrap around) of the previous segment.

For an **external trigger source**, switchover to any segment is also performed by changing the entry at **Next Segment**. In addition, consecutive switchover to the next segment is performed on the occurrence of each trigger event. The currently output segment is indicated at **Current Segment**. When the last segment of the multi segment waveform has been output, the sequence starts again with the output of the first segment after the next trigger event.. Depending on the selected **Extended Trigger Mode** the new segment is output either at once or only after the complete output (wrap around) of the previous segment.

Remote-control command:

```
SOUR:BB:ARB:WSEG:NEXT 1
```

The lower part of the menu is used for setting triggers and clocks, as well as for file management. A simple sinewave signal can also be output for test purposes.

### Trigger/Marker - ARB

Calls the Trigger and Marker menu.

This menu is used to select the trigger source, set the time delay on an external trigger signal and configure the marker output signals (see section "[Trigger/Marker/Clock - ARB MOD Menu](#)", page 4.248).

Remote-control command: n.a.

---

<b>Execute Trigger - ARB</b>	<p>Executes trigger manually. A manual trigger can be executed only when an internal trigger source and a trigger mode other than Auto are selected.</p> <p>Remote-control commands: SOUR:BB:ARB:TRIG:SOUR INT SOUR:BB:ARB:SEQ RETR SOUR:BB:ARB:TRIG:EXEC</p>
<b>Clock - ARB</b>	<p>Calls the Clock menu. The Clock menu is used to select the clock source (see section "<a href="#">Trigger/Marker/Clock - ARB MOD Menu</a>", page 4.248).</p> <p>Remote-control command: n.a.</p>
<b>Sine Testsignals - ARB</b>	<p>Calls the menu for generating sinusoidal test signals (see section "<a href="#">Sine Test Signals - ARB MOD Menu</a>" page 4.255).</p> <p>Remote-control command: n.a.</p>
<b>Multi Segment - ARB</b>	<p>Calls the menu for calculating multi segment waveforms (see section "<a href="#">Create Multi Segment Waveforms - ARB Menu</a>" page 4.257).</p> <p>Remote-control command: n.a.</p>
<b>Multi Carrier - ARB</b>	<p>Calls the menu for calculating multi carrier waveforms (see section "<a href="#">Create Multi Carrier Waveforms - ARB Menu</a>" page 4.263).</p> <p>Remote-control command: n.a.</p>

## Trigger/Marker/Clock - ARB MOD Menu

The **Trigger/Marker/Clock** menu is used to enter settings for triggers and markers, and to select the clock source. The menu offers internal triggering as well as the two external trigger inputs TRIGGER 1 and 2, and in the case of two-path instruments, it also offers internal triggering by the second path.

The Trigger menu is accessed via the **ARB MOD** main menu.

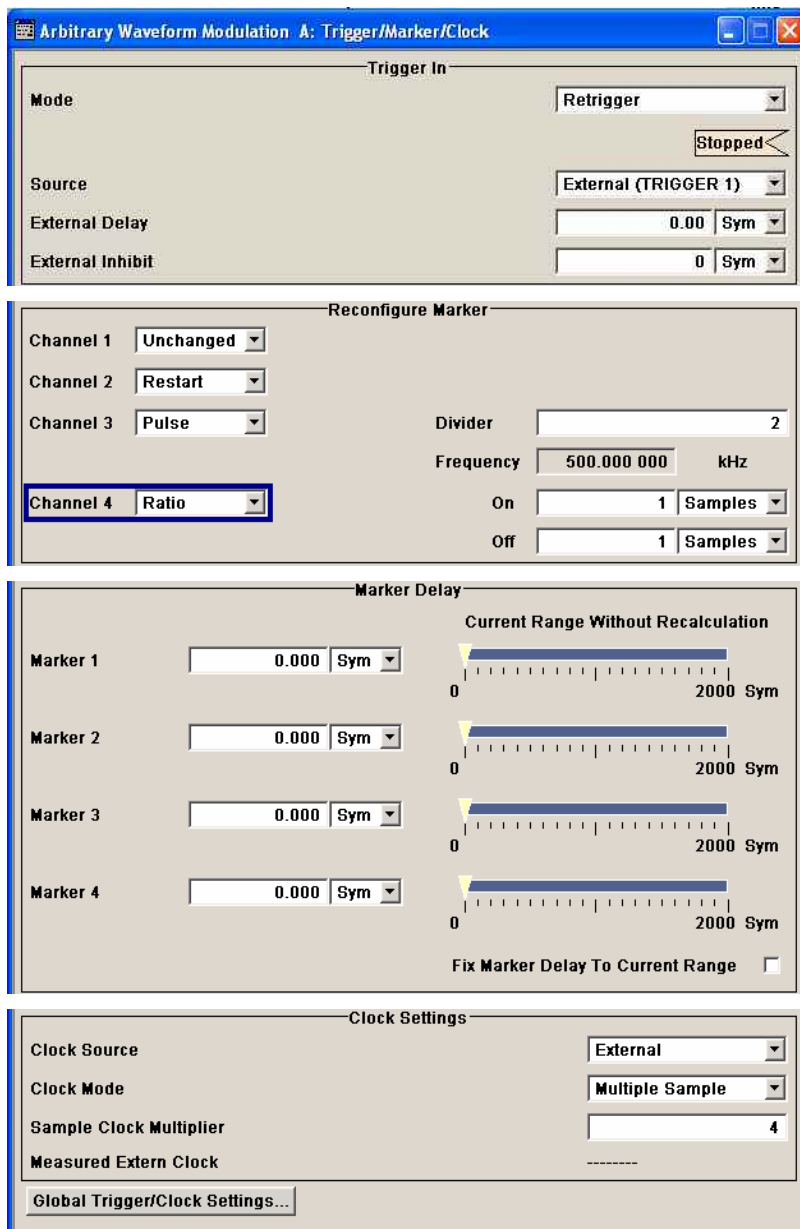

The **Trigger In** section is where the trigger for the waveform is set. Various parameters will be provided for the settings, depending on which trigger source - internal or external - is selected. The current status of signal output (**Running** or **Stopped**) is indicated for all trigger modes.

In the **Marker Mode** section markers can be defined in addition to the marker settings already defined in the waveform file.

The **Marker Delay** section is where a marker signal delay can be defined, either without restriction or restricted to the dynamic section, i.e., the section in which it is possible to make settings without restarting signal and marker output.

The **Clock Settings** section is where the clock source is selected and - in the case of an external source - the clock type.

The **Global Trigger/Clock Settings** button leads to a submenu for general trigger, clock and external input settings.

The **Trigger In** section is used to configure the trigger signal for the ARB modulation. The current status of waveform output is indicated for all trigger modes.

**Trigger Mode - ARB**

Selects trigger mode.

For multi segment waveforms, signal output is determined by the Extended Trigger Mode also (see main menu)

**Auto** The waveform or segment is output continuously. Signal output starts immediately when ARB modulation is enabled, trigger events are ignored.

Remote-control command:  
SOUR:BB:ARB:SEQ AUTO

**Retrigger** The waveform output continuously. Signal output starts immediately when ARB modulation is enabled, a trigger event (internal or external) causes a restart.

Remote-control command:  
SOUR:BB:ARB:SEQ RETR

**Armed\_Auto** The waveform is output only when a trigger event occurs. Then the waveform is output continuously. Subsequent trigger events are ignored

Button **Arm** stops waveform output. A subsequent trigger event (internal with **Execute Trigger** or external) causes a restart.

Remote-control command:  
SOUR:BB:ARB:SEQ AAUT

**Armed\_Retrigger** The waveform is output only when a trigger event occurs. Then the waveform is output continuously. Every subsequent trigger event (internal with **Execute Trigger** or external) causes a restart.

Button **Arm** stops waveform output. A subsequent trigger event (internal with **Execute Trigger** or external) causes a restart.

Remote-control command:  
SOUR:BB:ARB:SEQ ARET

**Single** The waveform is output only when a trigger event occurs. Then the waveform is output once in the length specified in **Signal Duration**.

Every subsequent trigger event (internal with **Execute Trigger** or external) causes a restart.

Remote-control command:  
SOUR:BB:ARB:SEQ SING



**Signal Duration Unit - ARB** Defines the unit for the entry of the length of the signal sequence to be output in the **Single** trigger mode. Available units are samples or sequence length (SL).

Remote-control commands:  
SOUR:BB:ARB:TRIG:SLUN SAMP

**Signal Duration - ARB** Enters the length of the signal sequence to be output in the **Single** trigger mode. The unit of the entry is defined under **Signal Duration Unit**. It is possible to output deliberately just part of the waveform, an exact sequence of the waveform, or a defined number of repetitions of the waveform.

Remote-control commands:  
SOUR:BB:ARB:TRIG:SLEN 2

**Running - Stopped - ARB** Displays the status of waveform output for all trigger modes.

Remote-control command:  
SOUR:BB:ARB:TRIG:RMOD?  
Response: RUN or STOP

**Running** The waveform is output; a trigger was (internally or externally) initiated in triggered mode.

For selection **Armed\_Auto** and **Armed\_Retrigger** waveform output can be stopped with the **Arm** button. A subsequent trigger event (internal with **Execute Trigger** or external) causes a restart.

**Stopped** The Waveform output is stopped. The instrument waits for an internal or external trigger event to restart. ARB modulation is disabled (**State Off**).

**Arm - ARB** Stops waveform output. This button appears only with **Running** signal output in the **Armed\_Auto** and **Armed\_Retrigger** trigger modes.

Signal output can be restarted by a new trigger (internally with **Execute Trigger** or externally).

Remote-control command:  
SOUR:BB:ARB:TRIG:ARM:EXEC

**Execute Trigger - ARB** Executes trigger manually. A manual trigger can be executed only when an internal trigger source and a trigger mode other than Auto have been selected.

Remote-control commands:  
SOUR:BB:ARB:TRIG:SOUR INT  
SOUR:BB:ARB:SEQ RETR  
SOUR:BB:ARB:TRIG:EXEC

**Trigger Source - ARB**

Selects trigger source.

**Internal**

The trigger event is executed by **Execute Trigger**. As a precondition a trigger mode other than **Auto** must be selected.

Remote-control command:

SOUR:BB:ARB:TRIG:SOUR INT

**Internal  
(Baseband A/B)**

The trigger event is executed by the trigger signal from the second path (two-path instruments only), depending on their setting. This makes it possible for instance to start the two paths synchronously or with a defined delay.

Remote-control command:

SOUR:BB:ARB:TRIG:SOUR OBAS

**External  
(TRIGGER 1|2)**

The trigger event is executed with the aid of the active edge of an external trigger signal. The trigger signal is supplied via the TRIGGER 1 or TRIGGER 2 connector.

The polarity, the trigger threshold and the input impedance of the TRIGGER input can be set in the **Global Trigger Settings** menu.

**Note:**

*For multi segment waveforms, an external trigger source can be used for cyclical output of the segments. Each trigger event starts the output of the next segment. After the last segment, the first segment is output again.*

Remote-control command:

SOUR:BB:ARB:TRIG:SOUR EXT | BEXT

**Trigger Delay - ARB**

Sets trigger signal delay in samples on external triggering or, in case of two-path instruments, on internal triggering via the second path.

This enables the R&S Signal Generator to be synchronized with the device under test or other external devices.

**Note:**

*For two-path instruments, the delay can be set separately for each of the two paths.*

Remote-control command:

SOUR:BB:ARB:TRIG:EXT:DEL 0

SOUR:BB:ARB:TRIG:OBAS:DEL 0

**Trigger Inhibit - ARB**

Sets the duration for inhibiting a new trigger event subsequent to triggering. The input is to be expressed in samples.

In the **Retrigger** mode, every trigger signal causes signal output to restart. This restart is inhibited for the specified number of samples:

This parameter is only available on external triggering or, in case of two-path instruments, on internal triggering via the second path.

**Note:**

*For two-path instruments, the trigger inhibit can be set separately for each of the two paths.*

Remote-control command:

SOUR:BB:ARB:TRIG:EXT:INH 0

SOUR:BB:ARB:TRIG:OBAS:INH 0

In the **Marker Mode** section markers can be defined in addition to the marker settings already defined in the waveform file.

**Marker x - ARB**

Selects a marker signal on the MARKER outputs.

**Note:**

*The marker trace in the waveform file remains unchanged in any case. It is not overwritten, even if something else than **Unchanged** has been selected.*

**Unchanged**

The marker signal remains unchanged as defined in the waveform file.

Remote-control command:

SOUR:BB:ARB:TRIG:OUTP1:MODE UNCH

**Restart**

A brief marker signal is generated at the start of the waveform or segment.

Remote-control command:

SOUR:BB:ARB:TRIG:OUTP1:MODE REST

**Pulse**

A regular marker signal is generated. The pulse frequency is defined by entering a divider. The frequency is derived by dividing the sample rate by the divider. The input box for the divider opens when **Pulse** is selected, and the resulting pulse frequency is displayed below it.

The precision of the frequency setting depends on the sampling rate. The maximum pulse frequency is equal to half of the sampling rate.

Divider	<input type="text" value="2"/>
Frequency	500.000 000 kHz

Remote-control command:

SOUR:BB:ARB:TRIG:OUTP1:MODE PULS

SOUR:BB:ARB:TRIG:OUTP1:PULS:DIV 4

SOUR:BB:ARB:TRIG:OUTP1:PFR?

**Pattern**

A marker signal that is defined by a bit pattern is generated. The pattern has a maximum length of 32 bits and is defined in an input field which opens when **pattern** is selected.

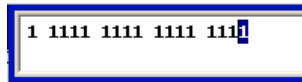

The pattern bits switch the marker signal to high and low state.

Remote-control command:

```
SOUR:BB:ARB:TRIG:OUTP1:MODE PATT
SOUR:BB:ARB:TRIG:OUTP1:PATT #B11001,5
```

**ON/OFF ratio**

A regular marker signal that is defined by an ON/OFF ratio is generated. A period lasts one ON and OFF cycle.

Start of signal

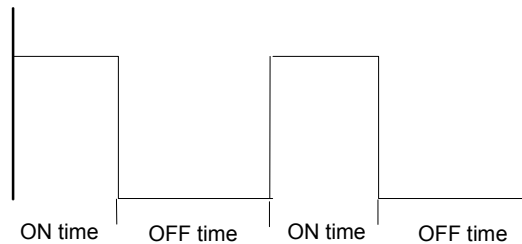

The ON time and OFF time are each expressed as a number of samples and are set in an input field which opens when **ON/OFF ratio** is selected.

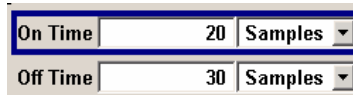

Remote-control command:

```
SOUR:BB:ARB:TRIG:OUTP1:MODE RAT
SOUR:BB:ARB:TRIG:OUTP1:OFFT 30
SOUR:BB:ARB:TRIG:OUTP1:ONT 20
```

The delays for the marker output signals are entered in the **Marker Delay** section.

**Marker x Delay - ARB**

Enters the delay between the marker signal at the marker outputs and the start of the signal.

The input is expressed as a number of samples. If the setting "**Fix marker delay to dynamic range**" is enabled, the setting range is restricted to the dynamic range. In this range the delay of the marker signals during signal output can be set without restarting the marker and signal.

Remote-control command:

```
SOUR:BB:ARB:TRIG:OUTP2:DEL 2
```

<b>Current Range without Recalculation - ARB</b>	<p>Displays the dynamic range within which the delay of the marker signals can be set without restarting the marker and signal.</p> <p>Remote-control command:  <code>SOUR:BB:ARB:TRIG:OUTP2:DEL:MAX?</code>  <code>SOUR:BB:ARB:TRIG:OUTP2:DEL:MIN?</code></p>
<b>Fix marker delay to current range - ARB</b>	<p>Restricts the marker delay setting range to the dynamic range. In this range the delay can be set without restarting the marker and signal.</p> <p>Remote-control command:  <code>SOUR:BB:ARB:TRIG:OUTP:DEL:FIX ON</code></p>
<p>The <b>Clock Settings</b> section is used to select the clock source.</p>	
<b>Clock Source - ARB</b>	<p>Selects the clock source (also see section "<a href="#">Clock Signals</a>", page 4.189).</p>
<b>Internal</b>	<p>The internal clock reference is used to generate the sample clock.</p> <p>Remote-control command:  <code>SOUR:BB:ARB:CLOC:SOUR INT</code></p>
<b>External</b>	<p>The external clock reference is fed in as the sample clock or a multiple thereof via the CLOCK connector.</p> <p>The polarity of the clock input can be changed with the aid of Global Trigger/Clock Settings.</p> <p>In the case of two-path instruments, this selection applies to path A.</p> <p>Remote-control command:  <code>SOUR:BB:ARB:CLOC:SOUR EXT</code></p>
<b>Clock Mode - ARB</b>	<p>Enters the type of externally supplied clock.</p>
<b>Sample</b>	<p>A sample clock is supplied via the CLOCK connector.</p> <p>Remote-control command:  <code>SOUR:BB:ARB:CLOC:MODE SAMP</code></p>
<b>Multiple</b>	<p>A multiple of the sample clock is supplied via the CLOCK connector; the sample clock is derived internally from this.</p> <p>The <b>Multiplier</b> window provided allows the multiplication factor to be entered.</p> <p>Remote-control command:  <code>SOUR:BB:ARB:CLOC:MODE MSAM</code></p>
<b>Sample Clock Multiplier - ARB</b>	<p>Enters the multiplication factor for clock type <b>Multiple</b>.</p> <p>Remote-control command:  <code>SOUR:BB:ARB:CLOC:MULT 4</code></p>

**Measured External Clock - ARB** (External Clock Source only) Indicates the measured frequency of the external clock signal. Thus, screening of the external clock is possible.

The frequency is only indicated when external clock source is selected.

Remote-control command:

CLOC:INP:FREQ?

**Global Trigger/Clock/Input Settings - ARB** Calls the **Global Trigger/Clock/Input Settings** menu. This menu is used among other things for setting the trigger threshold, the input impedance and the polarity of the clock and trigger inputs.

In the case of two-path instruments these settings are valid for both paths.

The parameters in this menu affect all digital modulations and standards, and are described in the section "[Global Trigger/Clock/Input Settings – Setup -Environment](#)".

## Sine Test Signals - ARB MOD Menu

The **Sine Test Signals** menu is accessed via the **ARB MOD** main menu.

The menu can be used to configure a sinusoidal test signal. A sine wave is always generated on the I path, and optionally a sine wave of the same frequency but phase-shifted can be generated on the Q path.

The signal actually set is displayed in graphical form in the center of the menu.

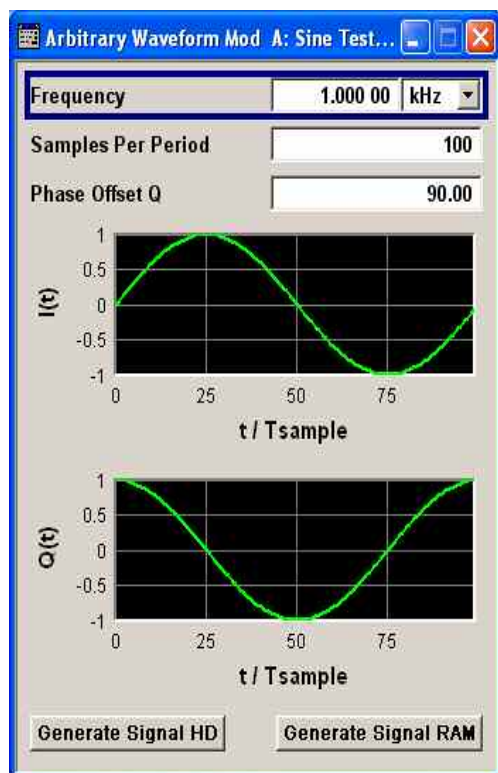

---

<b>Frequency - ARB</b>	Enters the frequency of the test signal. Remote-control command: SOUR:BB:ARB:TSIG:SINE:FREQ 2 MHz
<b>Samples per Period - ARB</b>	Enters the number of sample values required from the sine wave per period. The resulting clock rate must not exceed the maximum ARB clock rate (100 MHz). The number of sample values is automatically restricted by reference to the set frequency. Remote-control command: SOUR:BB:ARB:TSIG:SINE:SAMP 35
<b>Phase Offset Q - ARB</b>	Enters the phase offset of the sinewave signal on the Q channel relative to the sinewave signal on the I channel. Remote-control command: SOUR:BB:ARB:TSIG:SINE:PHAS 75DEG
<b>Generate Signal HD - ARB</b>	Generates a signal and saves it to a file. The File Select window opens automatically and the signal can be stored as a waveform file. Remote-control command: SOUR:BB:ARB:TSIG:SINE:CRE:NAM 'sine_test'
<b>Generate Signal RAM - ARB</b>	Generates a signal and uses it as output straight away. Remote-control command: SOUR:BB:ARB:TSIG:SINE:CRE

## Create Multi Segment Waveforms - ARB Menu

The **Multi Segment...** menu is accessed via the **ARB** main menu.

The menu can be used to create a multi segment waveform from existing waveforms and save it under its own name. As with normal waveforms, the file extension is **\*.wv**. Information on whether a file is a multi segment waveform is displayed in the File menu with the tag information when a waveform is loaded.

If the combined waveforms have different sample rates, they can be adapted to a common sample rate by resampling. By the same procedure the instantaneous amplitude of the various waveforms can be scaled to a common rms level.

The configuration of a multi segment waveform, that is to say details of how it is made up from different waveforms, the level and clock rate settings, and the file name, can be saved separately in a list. The file extension is **\*.inf\_mswv**. This method can be used to create any number of configurations as a basis for defining further multi segment waveforms.

Example for the creation of a multi segment waveform file.

1. Create empty list (**New List**)
2. Append two or more waveform files (**Append** or **Insert**)
3. Set level and clock mode (**Level** and **Clock**)
4. Enter file name (**Output File**)
5. Save configuration (**Save List**)
6. Save multi segment waveform (**Create** or **Create and Load**)

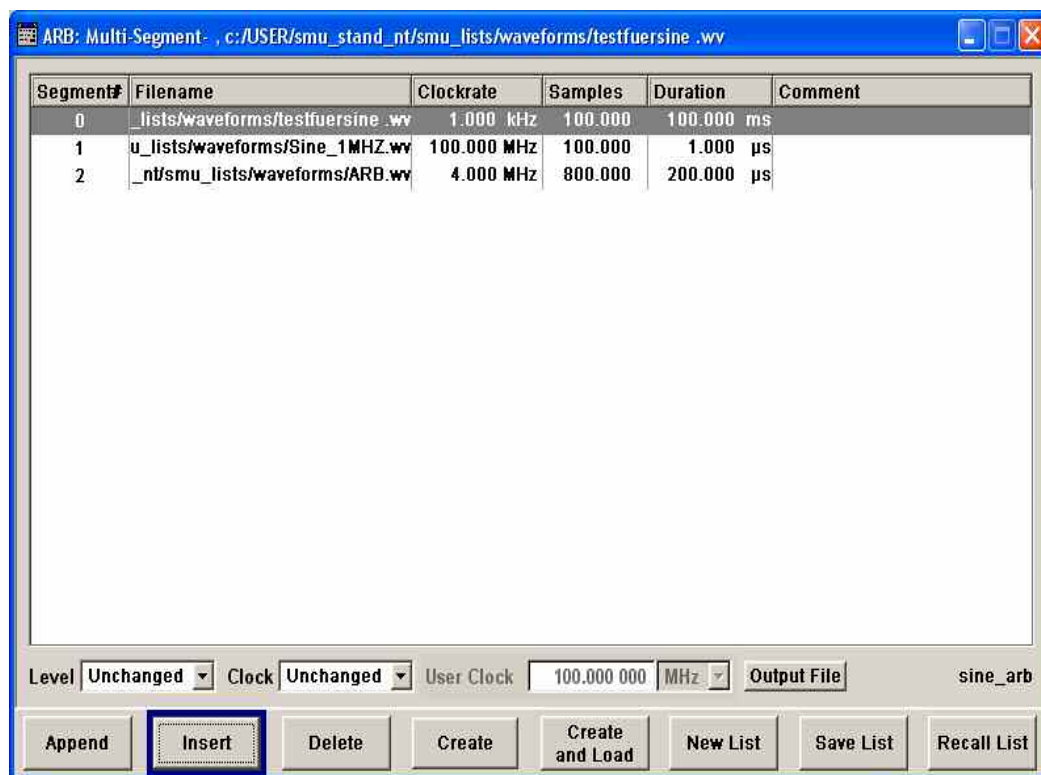



**Multi Segment Table - Multi Segment ARB** The table lists the individual waveforms (segments) of the selected multi segment waveform. The information about the segments is taken from the tags of the corresponding waveform files.

<b>Segment#</b>	<p>Indication of segment index. The segment index is used to select the segment to be output.</p> <p>The segment index also defines the sequence of the output during external triggering in the <b>Next Segment</b> or <b>Next Segment Seamless</b> trigger modes.</p> <p>Remote-control command: n.a.</p>
<b>File Name</b>	<p>Indication of the path and waveform file name of the segment.</p> <p>Remote-control command: n.a.</p>
<b>Clock Rate</b>	<p>Indication of the clock rate of the segment.</p> <p>The polarity of the clock input can be changed with the aid of <b>Global Trigger/Clock Settings</b>.</p> <p>Remote-control command: n.a.</p>
<b>Duration</b>	<p>Indication of the segment duration.</p> <p>Remote-control command: n.a.</p>
<b>Samples</b>	<p>Indication of the number of samples in the segment.</p> <p>Remote-control command: n.a.</p>
<b>Comment</b>	<p>Indication of the comment on the segment</p> <p>Remote-control command: n.a.</p>

**Level - Multi Segment ARB** Defines the level mode for the multi segment waveform.

<b>Unchanged</b>	<p>Segments are output exactly as defined in the files. The <b>Level</b> display applies only to the segment with the highest rms value. In some circumstances the remaining segments are output at a lower level than that displayed.</p> <p>Remote-control command: SOUR:BB:ARB:CONF:LEV:MODE UNCH</p>
<b>Equal RMS</b>	<p>Segments are output so that all segments have the same rms value. The <b>Level</b> display applies to all segments.</p> <p>Remote-control command: SOUR:BB:ARB:CONF:LEV:MODE ERMS</p>

<b>Clock - Multi Segment ARB</b>	Selects the clock rate mode for the multi segment waveform.
<b>Unchanged</b>	<p>A segment is output with the clock rate defined in the file.</p> <p>If segments have different clock rates, extended trigger mode <b>Next Segment</b> allows internal segment switchovers only (<b>Internal</b> trigger source).</p> <p>Extended trigger mode <b>Next Segment Seamless</b> can only be selected if all segments have the same clock rate.</p> <p>Remote-control command:  <code>SOUR:BB:ARB:WSEG:CONF:CLOC:MODE UNCH</code></p>
<b>Highest</b>	<p>All segments are output at the highest available clock rate.</p> <p>This mode provides very short switchover times between segments.</p> <p>The time for calculating the multi segment waveform is increased since the individual segments have to be resampled.</p> <p>Remote-control command:  <code>SOUR:BB:ARB:WSEG:CONF:CLOC:MODE HIGH</code></p>
<b>User</b>	<p>All segments are output at the clock rate defined in <b>User Clock</b>.</p> <p>This mode provides very short switchover times between segments.</p> <p>The time for calculating the multi segment waveform is increased since the individual segments have to be resampled.</p> <p>Remote-control command:  <code>SOUR:BB:ARB:WSEG:CONF:CLOC:MODE USER</code></p>
<b>User Clock - Multi Segment ARB</b>	<p>Defines the sample rate used for multi segment waveform output in case of Clock Mode <b>User</b>.</p> <p>Remote-control command:  <code>SOUR:BB:ARB:WSEG:CONF:CLOC 50MHz</code></p>
<b>Output file - Multi Segment ARB</b>	<p>Opens the <b>File</b> menu, where the file name of the multi segment waveform which has to be calculated can be entered.</p> <p>The multi segment waveform is saved under this name by clicking the <b>Create</b> or <b>Create and Load</b> button.</p> <p>A name must also be entered here before the list can be saved as a configuration file (<b>Save List</b>). In this case the name is needed for internal storage procedures. It is entered as the default name for the multi segment waveform file when loading the list.</p> <p>Remote-control command:  <code>SOUR:BB:ARB:WSEG:CONF:OFIL "Multi1"</code></p>

<b>Append - Multi Segment ARB</b>	<p>Opens the file menu to enter the file name of the waveform file to be appended.</p> <p>Remote-control command:  <code>SOUR:BB:ARB:WSEG:CONF:SEGM:APP 'arb2'</code></p>
<b>Insert - Multi Segment ARB</b>	<p>Opens the file menu to enter the file name of the waveform file to be inserted. The new waveform is inserted above the marked line.</p> <p>Remote-control command: n.a.</p>
<b>Delete- Multi Segment ARB</b>	<p>Deletes the selected segment.</p> <p>Remote-control command: n.a.</p>
<b>Create- Multi Segment ARB</b>	<p>Creates a new multi segment waveform using the current table entries.</p> <p>This multi segment waveform is saved with the file name specified in <b>Output File</b>. If no file name is specified, the File Manager opens so that the file name can be entered. As with normal waveforms, the file extension is <b>*.wv</b>.</p> <p>Depending on the configuration of the multi segment waveform, calculation may take some time. A panel with a progress bar and an <b>Abort</b> button appears during creating of the multi segment waveform.</p> <p>Remote-control command:  <code>SOUR:BB:ARB:WSEG:CRE "conf_16"</code></p> <p>(in remote control the configuration file to be used for the creation of the multi segment waveform is defined with the command:  <code>SOUR:BB:ARB:WSEG:CRE or SOUR:BB:ARB:WSEG:CLO.</code></p> <p>The file name of the waveform file is always determined with the command:  <code>SOUR:BB:ARB:WSEG:CONF:OFIL 'wv_name')</code></p>
<b>Create and Load- Multi Segment ARB</b>	<p>Creates a new multi segment waveform using the current table entries.</p> <p>This multi segment waveform is saved with the file name specified in <b>Output File</b>. If no file name is specified, the File Manager opens so that the file name can be entered. As with normal waveforms, the file extension is <b>*.wv</b>.</p> <p>Depending on the configuration of the multi segment waveform, calculation may take some time.</p> <p>Following this the <b>Create Multi Segment Waveform File</b> submenu is closed and the new multi segment waveform is loaded. The digital standard <b>ARB</b> is activated and the first segment of the waveform is output in accordance with the trigger settings.</p> <p>Remote-control command:  <code>SOUR:BB:ARB:WSEG:CLO "conf_16"</code></p> <p>(in remote control the configuration file to be used for the creation of the multi segment waveform is defined with command:  <code>SOUR:BB:ARB:WSEG:CRE or SOUR:BB:ARB:WSEG:CLO.</code></p> <p>The file name of the waveform file is always determined with the command:  <code>SOUR:BB:ARB:WSEG:CONF:OFIL 'wv_name')</code></p>

**New List- Multi Segment  
ARB**

Deletes all entries of the table. A new configuration table is created.

Remote-control command:

```
SOUR:BB:ARB:WSEG:CONF:SEL "new_mseg"
```

**Save List- Multi Segment  
ARB**

Saves the current entries of the table in a configuration file, including the level mode, clock mode and output file name settings.

The file name is entered in the **File** menu. Configuration files have the file extension **\*.inf\_mswv**. They can be used later as the basis for further multi segment waveforms.

Before a multi segment configuration file can be saved, a file name must be entered in **Output File**, since this is saved with the configuration file for internal purposes. This file name is also used as the default name for the multi segment waveform when loading the configuration file.

Remote-control command: n.a.

(in remote control the configuration file to be used for the creation of the multi segment waveform is defined with the command:

```
SOUR:BB:ARB:WSEG:CRE or SOUR:BB:ARB:WSEG:CLO.
```

The file name of the waveform file is always determined with the command:

```
SOUR:BB:ARB:WSEG:CONF:OFIL 'wv_name')
```

**Recall List- Multi Segment  
ARB**

Opens the file menu to select the configuration file to be edited.

Remote-control command:

```
SOUR:BB:ARB:WSEG:CONF:SEL "multi_seg2"
```

## Typical Applications for Multi Segment Waveforms - ARB Menu

### High Speed Switchovers

To test DUTs/chips using different test signals at high throughput requires extremely fast switchovers (for instance when testing ATE devices during manufacture). The following settings enable switching times of approx. 5  $\mu$ s and the test signals are scrolled through with the aid of an external trigger signal.

**Trigger Mode = Auto**

**Trigger Source = External Trigger 1 or 2**

If the waveforms have different sample rates:

**Clock Mode = Highest or User** (when creating the waveform in the Multi Segment Editor)

### Flexible Dynamic Switchovers

When testing DUTs using different test signals, it may be necessary to switch dynamically and flexibly between any of the test signals, for instance depending on the outcome of the previous test. When using remote control via an external computer, the following settings enable switching times of approx. 20 ms for segments with the same sample rate and approx. 200 ms for segments with different sample rates.

**Extended Trigger Mode = Next Segment**

**Trigger Mode = Auto**

**Trigger Source = Internal**

### Flexible Dynamic Switchovers without Signal Interruptions

Testing receivers requires a continuous output of different test signals without interrupting the signal. The test signals then produce a complex total signal with no signal gaps on switchover. Control procedures can use a simulated back channel of the receiver (trigger line or remote control).

Switching times depend on the length of the segment currently being output, since switchover to the next segment does not take place until the current segment comes to an end.

**Extended Trigger Mode = Next Segment Seamless**

**Trigger Mode = Auto**

**Trigger Source = Internal or External**

If the waveforms have different sample rates:

**Clock Mode = Highest or User** (when creating the waveform in the Multi Segment Editor)

## Create Multi Carrier Waveforms - ARB Menu

The **Multi Carrier...** menu is accessed via the **ARB** main menu.

The menu can be used to create a multi carrier waveform and save it under its own name. As with normal waveforms, the file extension is \*.**wv**. Information on clock rate, number of samples and creation day is displayed in the File menu when a waveform is loaded.

Multi carrier waveforms of up to 32 modulated carriers can be configured. The carriers are equally spaced and centered toward the RF frequency or baseband DC line, respectively. The carrier spacing is adjustable within the total available baseband bandwidth of 80 MHz. Each carrier can be separately defined in terms of power, phase and modulated input signal. Optionally, crest factor optimization can be applied.

Thus, multi carrier waveforms can be very easily configured as broadband test signals and used for such purposes as transmitter or receiver tests. In addition. Even complex multi carrier scenarios composed of signals from different digital standards can be created and used for these tests.

Example for the creation of a multi carrier waveform file.

1. Configure general settings
2. Configure carrier table
3. Enter file name of multi carrier waveform (**Output File**)
4. Save and load multi carrier waveform (**Create** or **Create and Load**)

## ARB Multi Carrier Submenu

The **Multi Carrier** submenu is divided into the following sections.



The upper part of the menu is used for calling the default settings and saving and recalling the submenu settings.

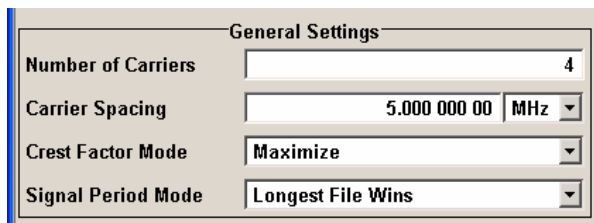

The **General Settings** section is used to configure the main multi carrier waveform.



The buttons in the middle part of the menu open submenus for defining the carrier table. The carrier settings can be checked in the graphical **Carrier Graph...** submenu.

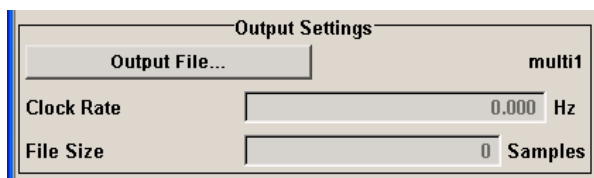

The **Output Settings** section indicates the name, the size and the clock rate of the multi carrier waveform (after calculation).

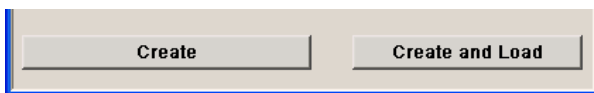

The buttons in the lower part of the menu activate creation and optionally loading of multi carrier waveform files into the main ARB menu.

The upper part of the menu is used for calling the default settings and saving and recalling existing ARB multi carrier submenu settings.

**Set to Default - ARB Multi Carrier** Calls default settings. The values are shown in the following table.

Remote-control command:  
 SOUR:BB:ARB:M CAR: PRES

Parameter	Value
General Settings	
Number of Carriers	1
Carrier Spacing	0 MHz
Crest Factor Mode	Off
Signal Period Mode	Longest file wins

**Save/Recall Frame - ARB Multi Carrier** Calls the **Save/Recall** menu.

From the **Save/Recall** menu the **File Select** windows for saving and recalling the configurations of the ARB **Multi Carrier** submenu and the **File Manager** can be called.

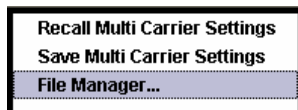

Remote-control command:  
 MMEM:MDIR 'F:\gen\gen\_lists\dm'  
 SOUR:BB:ARB:M CAR: SETT: CAT?  
 SOUR:BB:ARB:M CAR: SETT: LOAD 'M\_carr1'  
 SOUR:BB:ARB:M CAR: SETT: STOR 'M\_carr2'

The **General Settings** section is used to configure the Multi Carrier signal.

**Number of Carriers - ARB Multi Carrier** Sets the number of carriers for the multi carrier waveform.

By default the multi carrier table lists 1 carrier. A maximum of 32 carriers can be configured and activated.

When the number of carriers is increased, the multi carrier table is extended by adding further lines at the end of the table. If these carrier already have been defined before, the settings are preset according to the former settings. Otherwise the parameters are preset with the default values.

Remote-control command:  
 SOUR:BB:ARB:M CAR: CARR: COUN 22

**Carrier Spacing - ARB Multi Carrier** Sets the frequency spacing between adjacent carriers of the multi carrier waveform.

The carriers are arranged symmetrically around the RF carrier.

The maximum carrier spacing is limited to

$$\text{Carrier spacing} = \text{Total baseband bandwidth} / (\text{Number of carriers} - 1);$$

The total baseband bandwidth is 80 MHz.

**Note:**

*In order to avoid wrap-around problems, the effective **Carrier Spacing** might be slightly modified. The **Carrier Spacing** is rounded in that way that the carrier closest to the shows no phase jump assuming that the carrier is unmodulated.*

*For odd number of carriers:*

$$\text{RoundedCarrierSpacing} = 1 / \text{OutputSignalDuration} * \text{round}(\text{CarrierSpacing} * \text{OutputSignalDuration});$$

*For even number of carriers:*

$$\text{RoundedCarrierSpacing} = 2 / \text{OutputSignalDuration} * \text{round}(0.5 * \text{CarrierSpacing} * \text{OutputSignalDuration}).$$

Remote-control command:

SOUR:BB:ARB:MCAR:CARR:SPAC 10 kHz

**Crest Factor Mode - ARB Multi Carrier** Selects the mode for optimizing the crest factor by calculating the carrier phases.

The crest factor represents the ratio of the peak voltage value to the rms voltage value. The higher the crest factor and resulting dynamics of a signal, the greater the requirement for a power amplifier fed by the signal to be linear.

The following modes are available:

**Off** There is no automatic setting for minimizing or maximizing the crest factor. The **Phase** setting as defined in the carrier table is in use.

Remote-control command:

SOUR:BB:ARB:MCAR:CFAC:MODE OFF

**Minimize** The crest factor is minimized by internally calculating optimized carrier phases. The Phase setting displayed in the carrier table is invalid.

Remote-control command:

SOUR:BB:ARB:MCAR:CFAC:MODE MIN

**Maximize** The crest factor is maximized by internally calculating optimized carrier phases. The Phase setting displayed in the carrier table is invalid.

Remote-control command:

SOUR:BB:ARB:MCAR:CFAC:MODE MAX



**Signal Period Mode - ARB Multi Carrier**

Selects the mode for calculating the resulting signal period of the multi carrier waveform. The carrier table provides an information button to obtain sample rate and file length data of each carrier.

The resulting period is always calculated for all carriers in the carrier table irrespective of their state (ON/OFF).

**Note:**

*Wrap-around and timing problems may occur when I/Q signals of different length are used. Thus, demodulation of a carrier may be difficult or even impossible. It is therefore recommended to consider the timing already when creating the input I/Q files or to adjust the signal duration to the carrier which is subsequently demodulated (in this case, the other carriers are for interfering the signal only). These problems do not arise with signals of the same standard (e.g. 3GPP).*

The following modes are available:

**Longest File Wins**

The resulting signal period is defined by the longest I/Q file in the carrier table. Shorter I/Q files are periodically repeated.

Remote-control command:

SOUR:BB:ARB:M CAR:TIME:MODE LONG

**Shortest File Wins**

The resulting signal period is defined by the shortest I/Q file in the carrier table. Only the first part of longer I/Q files is used.

Remote-control command:

SOUR:BB:ARB:M CAR:TIME:MODE SHOR

**User**

The signal period can be set by the user in the **Signal Period** field. Shorter I/Q files are repeated periodically, and only the first part of longer I/Q files is used.

Remote-control command:

SOUR:BB:ARB:M CAR:TIME:MODE USER

**Signal Period - ARB Multi Carrier**

Sets the signal period in Signal Duration Mode **User**. Shorter I/Q files are repeated periodically, and only the first part of longer I/Q files is used.

Remote-control command:

SOUR:BB:ARB:M CAR:TIME 1s

The buttons in the middle part of the menu open submenus for defining the carrier table. The carrier settings can be checked in the graphical **Carrier Graph** submenu. The **Carrier Table Assistant** section can be used to set a selectable carrier range.

**Carrier Table Submenu - ARB Multi Carrier**

Calls the table for configuring individual carriers. A selectable carrier range can be set with the aid of the optional **Carrier Table Assistant**. The multi carrier configuration can be checked with the aid of the **Carrier Graph**.

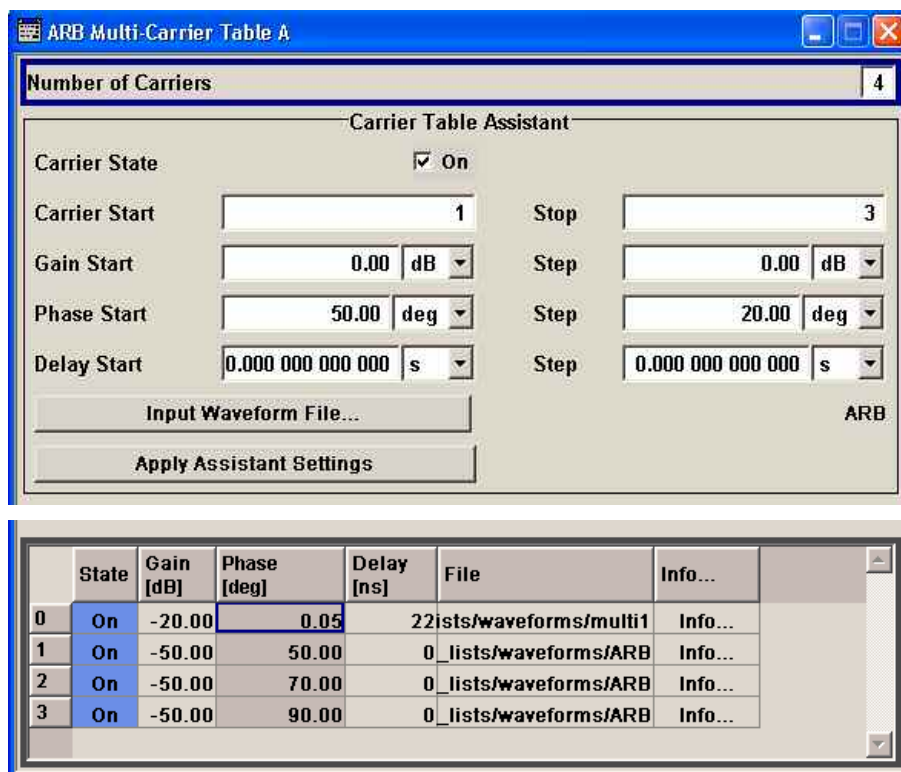

The **Carrier Table Assistant** serves as an optional mean to quickly set up a multi carrier scenario within a specified carrier range.

#### Number of Carriers - ARB Multi Carrier

Defines the number of carriers of the multi carrier waveform.

This parameter is identical to that in the **General Setting** section.

Remote-control command:

```
SOUR:BB:ARB:MCAR:COUN 22
```

#### Carrier State - ARB Multi Carrier

Switches the carriers in the range **Carrier Start** to **Carrier Stop** on/off.

Remote-control command

```
SOUR:BB:ARB:MCAR:EDIT:CARR:STAT ON
```

#### Carrier Start - ARB Multi Carrier

Defines the start index of the carrier range to which the assistant settings are intended to apply.

Remote-control command:

```
SOUR:BB:ARB:MCAR:EDIT:CARR:STAR 2
```

#### Carrier Stop - ARB Multi Carrier

Defines the stop index of the carrier range to which the assistant settings are intended to apply.

Remote-control command:

```
SOUR:BB:ARB:MCAR:CARR:CARR:STOP 20
```

#### Gain Start - ARB Multi Carrier

Sets the gain of the carrier marked by **Carrier Start**.

Remote-control command:

```
SOUR:BB:ARB:MCAR:EDIT:CARR:POW 0 dB
```

<b>Gain Step - ARB Multi Carrier</b>	<p>Sets the step width that is used to increment the gain</p> <p>The resulting carrier gain in the carrier table equals:</p> $\text{GainStart} + n * \text{Gain Step}$ <p>where n ranges from 0 to (Carrier Stop - Carrier Start).</p> <p>Remote-control command:</p> <pre>SOUR:BB:ARB:MCAR:EDIT:CARR:POW:STEP -0.2 dB</pre>
<b>Phase Start - ARB Multi Carrier</b>	<p>Sets the phase of the carrier marked by <b>Carrier Start</b>.</p> <p>Remote-control command:</p> <pre>SOUR:BB:ARB:MCAR:EDIT:CARR:PHAS 0</pre>
<b>Phase Step - ARB Multi Carrier</b>	<p>Sets the step width that is used to increment the phase.</p> <p>The resulting phase in the carrier table equals:</p> $\text{PhaseStart} + n * \text{PhaseStep}$ <p>where n ranges from 0 to (Carrier Stop – Carrier Start)</p> <p>Remote-control command:</p> <pre>SOUR:BB:ARB:MCAR:EDIT:CARR:PHAS:STEP 1DEG</pre>
<b>Delay Start - ARB Multi Carrier</b>	<p>Sets the delay of the carrier marked by <b>Carrier Start</b>.</p> <p>Remote-control command:</p> <pre>SOUR:BB:ARB:MCAR:EDIT:CARR:DEL 0</pre>
<b>Delay Step - ARB Multi Carrier</b>	<p>Sets the step width that is used to increment the delay</p> <p>The resulting delay in the carrier table equals:</p> $\text{DelayStart} + n * \text{DelayStep}$ <p>where n ranges from 0 to (Carrier Stop – Carrier Start).</p> <p>Remote-control command:</p> <pre>SOUR:BB:ARB:MCAR:EDIT:CARR:DEL:STEP 10us</pre>
<b>Input Waveform File - ARB Multi Carrier</b>	<p>Calls the <b>File</b> menu for selecting the inputfile with the I/Q signal to be modulated onto all carriers of the selected carrier range.</p> <p>Remote-control command:</p> <pre>SOUR:BB:ARB:MCAR:EDIT:CARR:FILE "iq_test"</pre>
<b>Apply Assistant Settings - ARB Multi Carrier</b>	<p>Transfer the assistant settings to the carrier table.</p> <p>Remote-control command:</p> <pre>SOUR:BB:ARB:MCAR:EDIT:CARR:EXEC</pre>

**Carrier Table - ARB Multi Carrier**

The table displays the settings of all available carriers. Previously applied assistant settings can be further refined. The number of lines corresponds to the number of carriers.

**Note:**

*The phase/deg settings are only valid if optimization of the crest factor is disabled (Crest Factor Mode = Off).*

No.	State	Gain [dB]	Phase [deg]	Delay [ns]	File	Info...
0	On	-20.00	0.05	22	ists/waveforms/multi1	Info...
1	On	-50.00	50.00	0	_lists/waveforms/ARB	Info...
2	On	-50.00	70.00	0	_lists/waveforms/ARB	Info...
3	On	-50.00	90.00	0	_lists/waveforms/ARB	Info...

**No.** Indicates the carrier index ranging from 0 to (number of carriers -1).

Remote-control command:  
 - individual carriers can be set using the commands:  
 SOUR:BB:ARB:MCAR:CARR: . .  
 by specifying the index in the parameter.

**State** Switches On/Off a carrier.

Remote-control command:  
 SOUR:BB:ARB:MCAR:CARR2:STAT ON

**Gain** Sets the gain of a carrier.

Remote-control command:  
 SOUR:BB:ARB:MCAR:CARR2:POW -30dB

**Phase** Sets the starting phase of a carrier.

Remote-control command:  
 SOUR:BB:ARB:MCAR:CARR2:PHAS 0DEG

**Delay** Sets the starting delay of a carrier.

Remote-control command:  
 SOUR:BB:ARB:MCAR:CARR2:DEL 2US

**File** Calls the **File** menu for selecting the input file with the I/Q signal to be modulated onto the carrier.

Remote-control command:  
 SOUR:BB:ARB:MCAR:CARR2:FILE "iq\_test"

**Info** Indicates the sample rate, number of I/Q value pairs (number of samples), and the resulting signal period of the selected I/Q input file.

Remote-control command: n.a.

**Carrier Graph - ARB Multi Carrier**

Calls a graphical representation of the current multi carrier configuration in the frequency domain.

The height of the bars corresponds to the chosen gain of each individual carrier. The bandwidth of the carriers signals is indicated by the width of the bars.

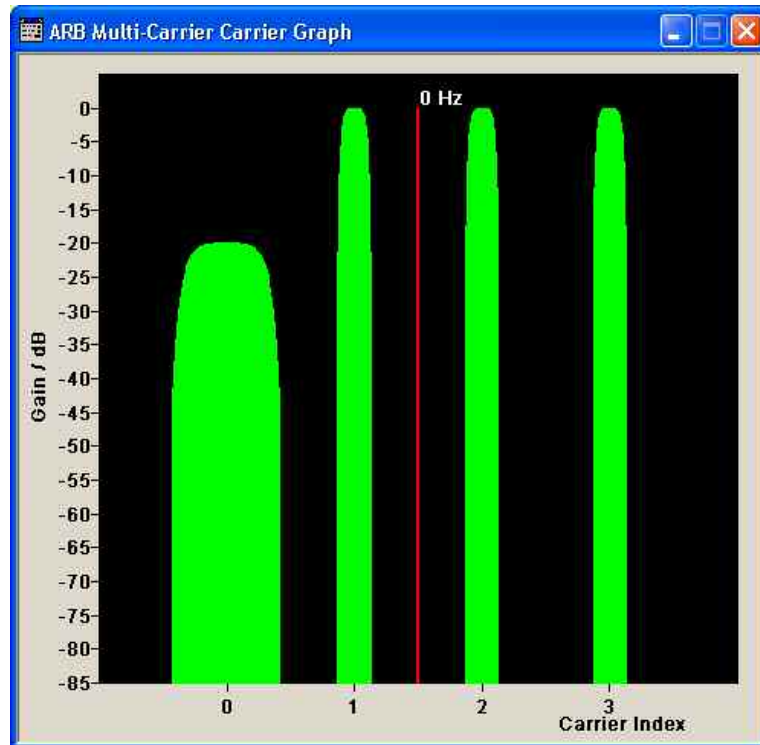

The **Output Settings** section in the multi carrier main menu indicates the name, the size and the clock rate of the currently calculated multi carrier output file.

**File - ARB Multi Carrier**

Opens the **File** menu, where the output file name of the multi carrier waveform which has to be calculated can be entered.

The multi carrier waveform is calculated and saved under this name by clicking the **Create** or **Create and Load** button.

Remote-control command:

```
SOUR:BB:ARB:WCAR:OFIL "Multi1"
```

**Clock Rate - ARB Multi Carrier**

Displays the resulting sample rate at which the multi carrier waveform is output by the arbitrary waveform generator. The output clock rate depends on the number of carriers, carrier spacing and input sample rate of the leftmost or rightmost carriers.

Remote-control command

```
SOUR:BB:ARB:MCAR:CLOC?
```

<b>File Size - ARB Multi Carrier</b>	<p>Displays the resulting number of samples of the multi carrier waveform.</p> <p>Remote-control command: SOUR:BB:ARB:MCA: SAMP?</p>
<b>Create - ARB Multi Carrier</b>	<p>Creates a new multi carrier waveform defined by the multi carrier table and General Setting entries.</p> <p>This multi carrier waveform is saved with the file name specified in <b>Output File</b>. If no file name is specified, the File Manager opens so that the file name can be entered. As with normal waveforms, the file extension is <b>*.wv</b>.</p> <p>Depending on the configuration of the multi carrier waveform, calculation may take some time. A panel with a progress bar and an <b>Abort</b> button appears during the calculation process.</p> <p>Remote-control command: SOUR:BB:ARB:MCA: CRE (in remote control the file name of the multi carrier waveform file is determined with command: SOUR:BB:ARB:MCA: OFIL 'wv_name')</p>
<b>Create and Load - ARB Multi Carrier</b>	<p>Creates a new multi carrier waveform defined by the multi carrier table and General Setting entries and loads it subsequently in the <b>ARB</b> main menu.</p> <p>This multi carrier waveform is saved with the file name specified in <b>Output File</b>. If no file name is specified, the File Manager opens so that the file name can be entered. As with normal waveforms, the file extension is <b>*.wv</b>.</p> <p>Depending on the configuration of the multi carrier waveform, calculation may take some time. A panel with a progress bar and an <b>Abort</b> button appears during the calculation process.</p> <p>Remote-control command: SOUR:BB:ARB:MCA: CLO (in remote control the file name of the waveform file is determined with command: SOUR:BB:ARB:MCA: OFIL 'wv_name')</p>

## Typical Applications for Multi Carrier Waveforms - ARB Menu

High Power Amplifiers of multi carrier base stations face increased requirements in terms of linearity and acceptable intermodulation performance. A standard transmitter test might be quickly setup by the following instructions.

- Load a standardized 3GPP downlink test model, e.g. **Test Model 1\_16**; Set State to **ON**
- Create a 3GPP Testmodel ARB file by activating **Generate Waveform File**.
- Setup a multi carrier scenario with 4 carriers and a carrier spacing of 5 MHz.
- Apply the input file containing the previously generated 3GPP testmodel to all 4 carriers.

## Contents Chapter 5 - Remote Control - Basics

<b>5 Remote Control - Basics .....</b>	<b>5.1</b>
Introduction - Remote Control Basics.....	5.1
Getting Started .....	5.2
Switchover to Remote Control.....	5.3
Remote Control via IEC/IEEE Bus .....	5.4
Remote Control via LAN Interface.....	5.5
LXI - LAN eXtensions for Instruments.....	5.10
Remote Control via USB Interface .....	5.15
Interface and Device Messages .....	5.16
Interface Messages .....	5.16
Device Messages (Commands and Device Responses).....	5.16
SCPI Command Structure and Syntax.....	5.18
Structure of a Command Line .....	5.20
Responses to Queries.....	5.21
Parameters .....	5.21
Overview of Syntax Elements .....	5.23
Instrument Model and Command Processing.....	5.24
Input Unit .....	5.24
Command Recognition.....	5.25
Data Base and Instrument Hardware.....	5.25
Status Reporting System.....	5.26
Output Unit .....	5.26
Command Sequence and Command Synchronization .....	5.27
Status Reporting System.....	5.30
Overview of the Status Register.....	5.30
Status Byte (STB) and Service Request Enable Register (SRE) ...	5.31
IST-Flag and Parallel Poll Enable Register (PPE) .....	5.31
Event Status Register (ESR) and Event Status Enable Register (ESE).....	5.32
Application of the Status Reporting System.....	5.33
Reset Values of the Status Reporting Systems .....	5.35





# 5 Remote Control - Basics

## Introduction - Remote Control Basics

This chapter provides:

- ◆ Instructions on how to set up the instrument for remote control operation.
- ◆ A general introduction to remote control of programmable instruments. This includes the description of the command structure and syntax according to the SCPI standard, the description of command execution and of the status registers.

The remote control commands of the instrument are described in detail after each related Instrument Function section. In addition, the description of each menu parameter is linked to the related remote control command.

In chapter 6, all remote control functions are described in detail. The subsystems are listed by alphabetical order according to SCPI. All commands and their parameters are listed by alphabetical order in the command list at the end of chapter 6. A list is provided for users of the R&S Signal Generator, which shows all commands that are compatible with the command set of the R&S Signal Generator SMIQ.

The instrument is equipped with the following interfaces for remote control:

- ◆ IEC/IEEE bus interface according to standard IEC 625.1/IEEE 488.2
- ◆ LAN interface: the network card uses 10/100/1000Mbps Ethernet IEEE 802.3u; the protocol is based on the VXI-11 standard.
- ◆ USB interface: The type B interface (device USB) is used for remote control.

The connectors are located at the rear of the instrument and permit a connection to a controller for remote control either via GPIB, via a local area network (LAN) or USB interface. The remote control interfaces and their interface functions are described in chapter 8.

A VISA installation on the controller is a prerequisite for remote control over LAN or USB interface. VISA is a standardized software interface library providing input and output functions to communicate with instruments. For more information about VISA refer to the user documentation. SCPI (**S**tandard **C**ommands for **P**rogrammable **I**nstruments) commands - messages - are used for remote control. Commands that are not taken from the SCPI standard follow the SCPI syntax rules. The instrument supports the SCPI version 1999. The SCPI standard is based on standard IEEE 488.2 and aims at the standardization of instrument control commands, error handling and the status registers. The tutorial "Automatic Measurement Control – A tutorial on SCPI and IEEE 488.2" from John M. Pieper (R&S order number 0002.3536.00) offers detailed information on concepts and definitions of SCPI.

This section assumes basic knowledge of programming and operation of the controller. A description of the interface commands can be obtained from the relevant manuals.

The requirements that the SCPI standard places on command syntax, error handling and configuration of the status registers are explained in detail in the following sections. Tables provide a fast overview of the bit assignment in the status registers. The tables are supplemented by a comprehensive description of the status registers.

The program examples for IEC/IEEE-bus programming are all written in VISUAL BASIC. A condition for programming in VISUAL BASIC is that the modules NIGLOBAL (Niglobal.bas) and VBIB32 (Vbib\_32.bas) are added to the projects.

**Note:**

Manual operation is designed for maximum possible operating convenience. In contrast, the priority of remote control is the "predictability" of the device status. Therefore, control programs should always define an initial device status (e.g. with the command \*RST) and then implement the required settings.

Drivers for the generator, e.g. IVI-COM and LabVIEW drivers, are available in the download area of the R&S product website (<http://www.rohde-schwarz.com/product/SMU200A>).

## Getting Started

The short and simple operating sequence given below permits fast putting into operation of the instrument and setting of its basic functions. As a prerequisite, the IEC/IEEE-bus address, which is factory-set to 28, must not have been changed.

- ◆ Connect instrument and controller using IEC/IEEE-bus cable and switch them on.
- ◆ Write and start the following program on the controller:

CALL IBFIND("DEV1", generator%)	'Open port to the instrument
CALL IBPAD(generator%, 28)	'Inform controller about instrument address
CALL IBWRT(generator%, "*RST;*CLS")	'Reset instrument
CALL IBWRT(generator%, "IQ:OUTP:STAT ON")	'Switch on the analog I/Q outputs
CALL IBWRT(generator%, "BB:DM:FORM FSK2")	'Set modulation type to FSK2
CALL IBWRT(generator%, "BB:DM:STAT ON")	'Switch on digital modulation

The set modulation signal is now applied at the analog I/Q-output of the instrument.

- ◆ To return to manual operation, press the LOCAL key at the front panel.

## Switchover to Remote Control

On power-on, the instrument is always in the manual operating state and can be operated via the front panel controls or via mouse and external keyboard.

In case of remote control via the IEC/IEEE bus, the instrument is set to remote control (REMOTE status) by means of an addressed command.

With remote control via Ethernet, remote control is not automatically set by means of a command. The instrument must be explicitly set to the REMOTE state, e.g. by sending the interface command **&GTR** (go to remote).

In the REMOTE state, instrument control from the front panel or via mouse and keyboard is disabled. Menus can be opened, however, e.g. to verify settings. Buttons and setting fields are displayed in gray and cannot be activated. REMOTE is displayed in the status line.

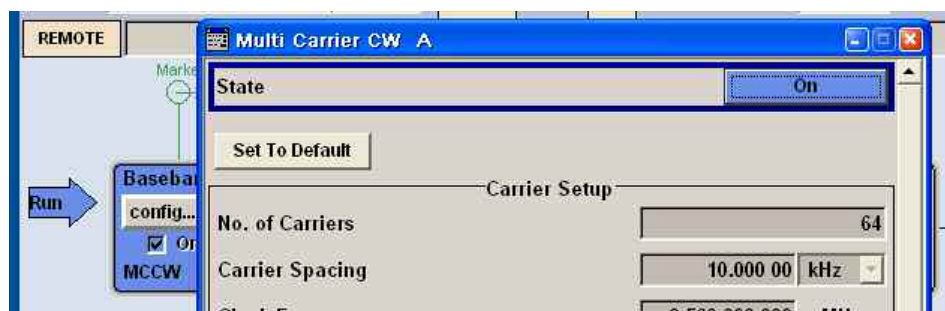

The instrument remains in the REMOTE mode until local control is selected with one of the following ways:

- manually with the **LOCAL** key on the front panel
- with the interface command **&GTL** via the remote-control interface
- manually with the Local button in the menu **Remote Control Channels**.

Switching from manual operation to remote control and vice versa does not affect the remaining instrument settings.

In the remote control mode, the front-panel keys and an external mouse or keyboard that may be connected can be disabled with command `:SYST:KLOC ON`. Menus cannot be opened in this case and switchover from remote control to manual operation is only possible by means of a remote-control command. Inadvertent switchover with the **LOCAL** key is not possible in this case.

Operation of the **LOCAL** key alone can be disabled with interface command **&LLO**.

## Remote Control via IEC/IEEE Bus

To be able to control the instrument via the IEC/IEEE bus, instrument and controller must be linked by an IEC/IEEE-bus cable. An IEC/IEEE-bus card, the card drivers and the program libraries for the programming language used must be provided in the controller.

The controller must address the instrument with the set IEC/IEEE-bus address. The IEC/IEEE bus address of the instrument is factory-set to 28. It can be changed manually in the **Environment - GPIB** menu or via IEC/IEEE bus with command `SYSTem:COMMunicate:GPIB: ADDRess`. Addresses 0 to 30 are permissible.

**Manually:**

**Setup - Remote - GPIB ...**



**Via IEC/IEEE bus:**

<code>CALL IBFIND("DEV1", generator%)</code>	'Open port to the instrument
<code>CALL IBPAD(generator%, 28)</code>	'Inform controller about old address
<code>CALL IBWRT(generator%, "SYST:COMM:GPIB:ADDR 18")</code>	'Set instrument to new address
<code>CALL IBPAD(generator%, 18)</code>	'Inform controller about new address

Sending the first command starts remote control operation.

Return to manual operation is possible via the front panel or the IEC/IEEE bus.

**Manually:**

- Press the **LOCAL** key.

---

### Notes:

*Before the transition, command processing must be completed as otherwise transition to remote control is performed immediately.*

*The **LOCAL** key can be disabled by the interface message `&LLO` (see chapter 8, section "[IEC/IEEE-Bus Interface Functions](#)") in order to prevent unintentional transition. In this case, transition to manual mode is only possible via the IEC/IEEE bus.*

*The **LOCAL** key can be enabled again by deactivating the `REN` line of the IEC/IEEE bus (see chapter 8, section "[IEC/IEEE Bus Interface](#)").*

---

**Via IEC/IEEE bus:**

...

`CALL IBLOC(generator%)` 'Set instrument to manual operation

...

## Remote Control via LAN Interface

For remote control via a network, the PC and the instrument must be connected via the LAN interface to a common network with TCP/IP network protocol.

Software for instrument control and the VISA program library must be installed on the controller.

Instrument control is via the VXI-11 standard protocol.

Only the IP address or the computer name (host name) is required for link setup. The IP address/computer name is part of the "visa resource string" used by the programs for identification and control of the instrument. The visa resource string has the form:

**TCPIP::ipaddr::inst0::INSTR**

**ipaddr** has to be replaced by the IP address or the computer name of the instrument.

For instance, if the instrument has the IP address 192.1.2.3, TCPIP::192.1.2.3::inst0::INSTR is the valid resource string. Specification of **inst0** in the resource string is optional. In this example, also TCPIP::192.1.2.3::INSTR is therefore a valid resource string.

A visa resource string with computer name could be TCPIP::RSSM1::INSTR, for instance.

**TCPIP** designates the network protocol used and **INSTR** indicates that the VXI-11 protocol is used.

---

*Note:*

*The visa resource string is indicated in the Setup-Remote -Ethernet menu.*

---

If several instruments are connected to the network, each instrument has its own IP address and associated resource string. The controller identifies these instruments by means of the resource string. In the example below, the program 'Measurement & Automation Explorer' from National Instruments is used for setting up an Ethernet remote-control link. Link setup with this program is easy and first tests can be performed. The R&S Signal Generator is preconfigured for networks using DHCP (dynamic host configuration protocol). If this configuration is used, the computer name must be entered at the position of the IP address. It is also possible to assign a fixed IP address to the instrument (see chapter 1, section "[Connection to the Network](#)").

**Setting up Control of the R&S Signal Generator in the 'Measurement & Automation Control' Program.**

1. Start program on the controller
2. Open the **Create new** menu with the right mouse key.

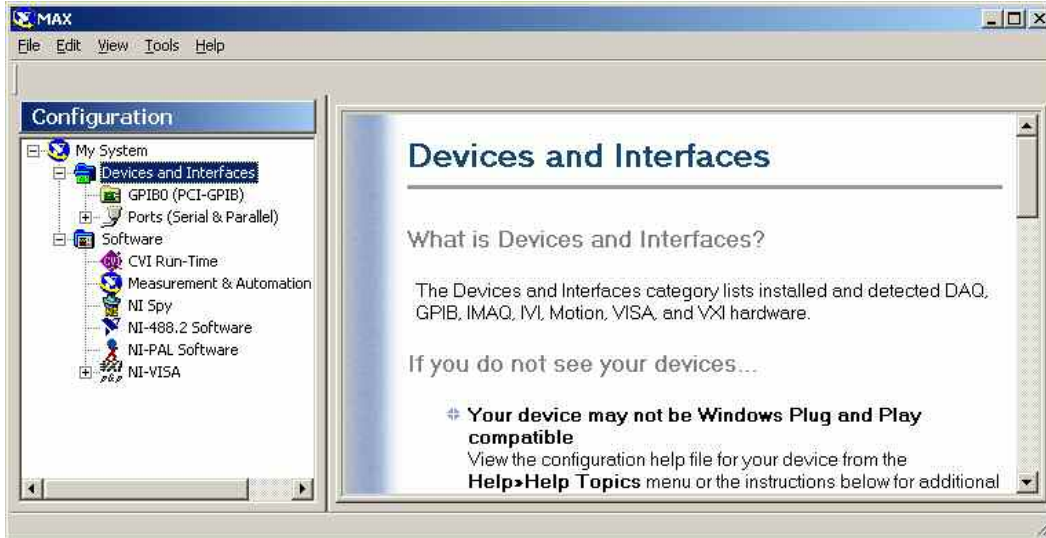

3. Select **TCP/IP Resource** and open the next page of the **Create new** menu with the right mouse key.



4. Enter the IP address of the R&S Signal Generator and select **VXI-11 Instrument** (the computer name may be entered instead).

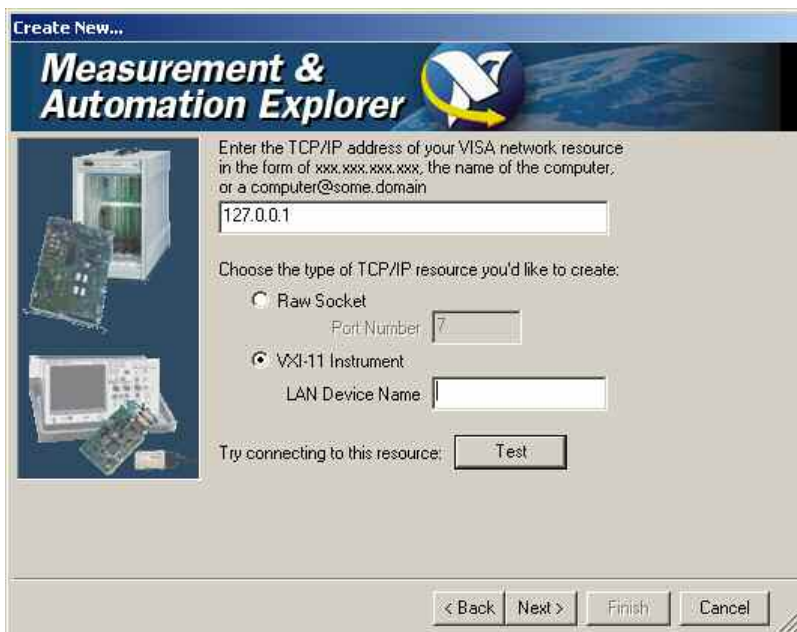

5. Press the **Test** button

A message indicates whether the link to the R&S Signal Generator can be set up or not. If a connection cannot be set up, check whether the controller and the instrument are connected to the network (network cable) and switched on. Correct spelling of the IP address or the computer name can also be checked. For further error location, inform the network administrator. In large networks, specification of additional addresses may be required for link setup, e.g. gateway and subnet mask, which are known to the network administrator.

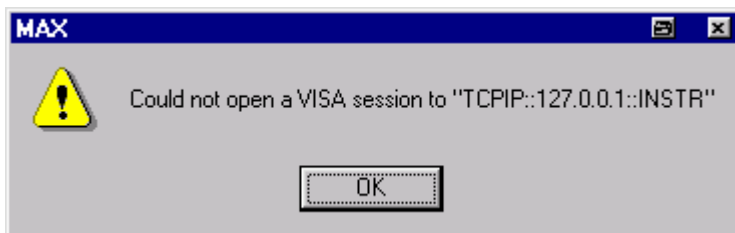
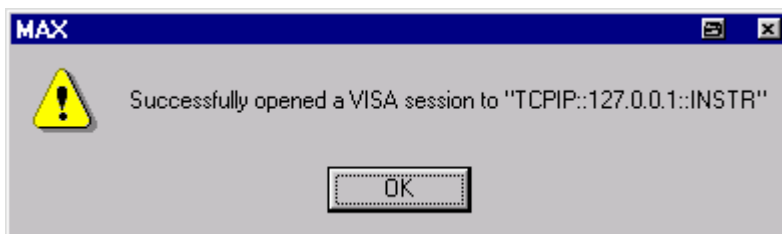



- Press the **Next** button. An alias name for the instrument can be entered in the next window. This name must not be mistaken for the computer name. It is only used for instrument identification within the program and displayed in the menu as an option in case of an Ethernet link.

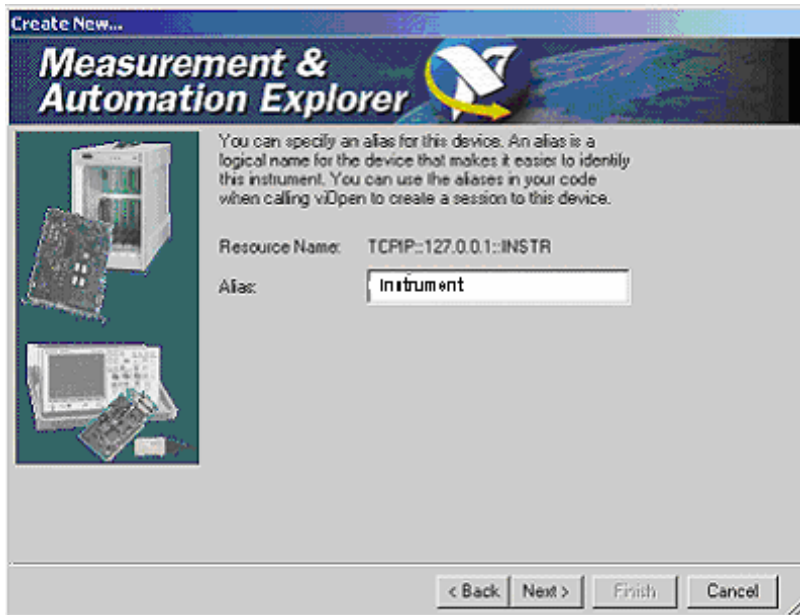

- Press **Next** and then the **Finish** button.  
The instrument is now registered in the program and can be addressed via the resource string or alias name.





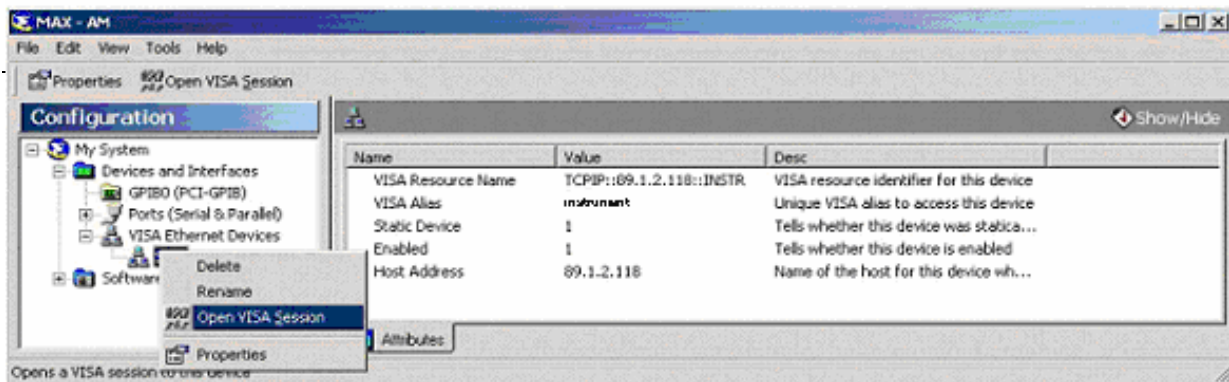

- On the **viWrite** tab under **Basic I/O**, commands can be sent to the instrument; instrument responses are displayed on the **viRead** tab (for further program operation refer to the online help of the program).

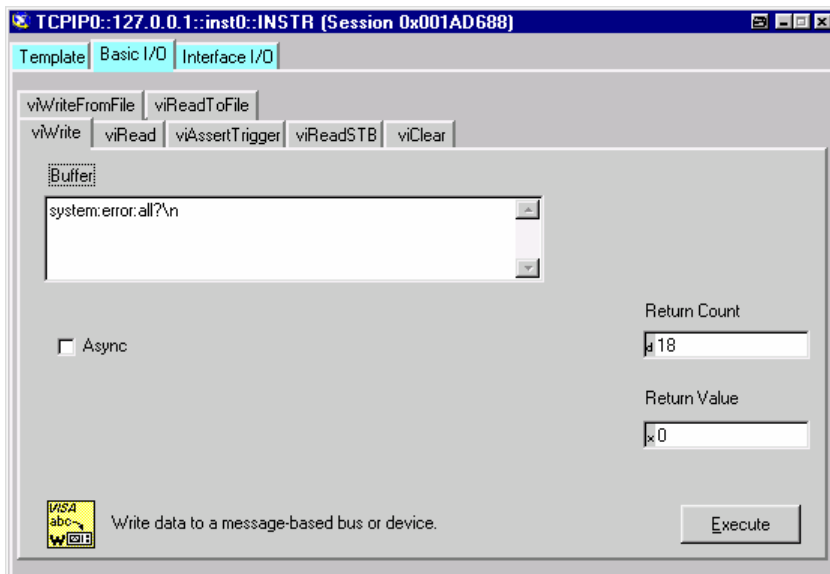

Return to manual operation is possible via the front panel or the LAN interface.

**Manually:**

- Press the **LOCAL** key.

*Notes:*

The **LOCAL** key can be disabled by the universal command **&LLO** (see chapter 8, section **VXI-11 Interface Messages**) in order to prevent unintentional transition. In this case, transition to manual mode is only possible via remote control.

The **LOCAL** key can be enabled again by the interface message **&NREN** (see chapter 8, section **VXI-11 Interface Messages**).

**Via IEC/IEEE bus:**

...

CALL IBLOC(generator%) 'Set instrument to manual operation

...

## LXI - LAN eXtensions for Instruments

LAN eXtensions for Instrumentation (LXI) is an instrumentation platform for measuring instruments and test systems that is based on standard Ethernet technology. LXI is intended to be the LAN-based successor to GPIB, combining the advantages of Ethernet with the simplicity and familiarity of GPIB. Like GPIB, LXI determines and standardizes the way the instrument behaves in a LAN. The LXI implementation by the R&S Signal Generators allows you to change certain LAN settings, to reset the LAN connection as well as function for easy instrument identification.

### LXI classes and LXI functionality

LXI-compliant instruments are divided into three classes, A, B and C, with the functionality of the classes hierarchically based one upon the other:

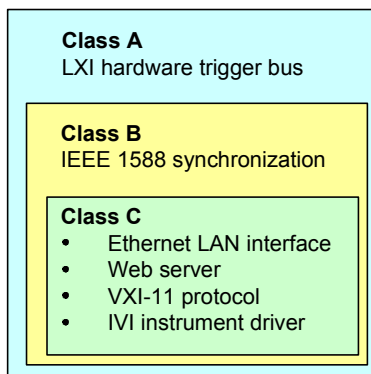

- ◆ **Class C** instruments are characterized by a common LAN implementation, including an ICMP ping responder for diagnostics. The instruments can be configured via a web browser; a LAN Configuration Initialize (LCI) mechanism resets the LAN configuration. The LXI class C instruments shall also support automatic detection in a LAN via the VXI-11 discovery protocol and programming by means of IVI drivers.
- ◆ **Class B** adds IEEE 1588 Precision Time Protocol (PTP) and peer-to-peer communication to the base class. IEEE 1588 allows all instruments on the same network to automatically synchronize to the most accurate clock available and then provide time stamps or time-based synchronization signals to all instruments with exceptional accuracy.
- ◆ **Class A** instruments are additionally equipped with the eight-channel hardware trigger bus (LVDS interface) defined in the LXI standard.

Instruments of classes A and B can generate and receive software triggers via LAN messages and communicate with each other without involving the controller.

The R&S Signal Generator complies with LXI class C and provides an Integrated **LXI Status** dialog for LXI status indication and reset of the LAN configuration (LAN Configuration Initialize, LCI).

---

#### Note:

For information about the LXI standard refer to the LXI website at <http://www.lxistandard.org>. See also "News from Rohde & Schwarz, article 2006/II - 190".

---

## LXI Browser Interface

The instrument's LXI browser interface works correctly with all W3C compliant browsers. To open the **Instrument Home Page** (welcome page), type the instrument's computer name (host name) or IP address in the address field of the browser on your PC, e.g <http://10.111.10.19>.

### Note:

*Do not add the missing zeros in the IP address, while opening the Instrument Home Page.*

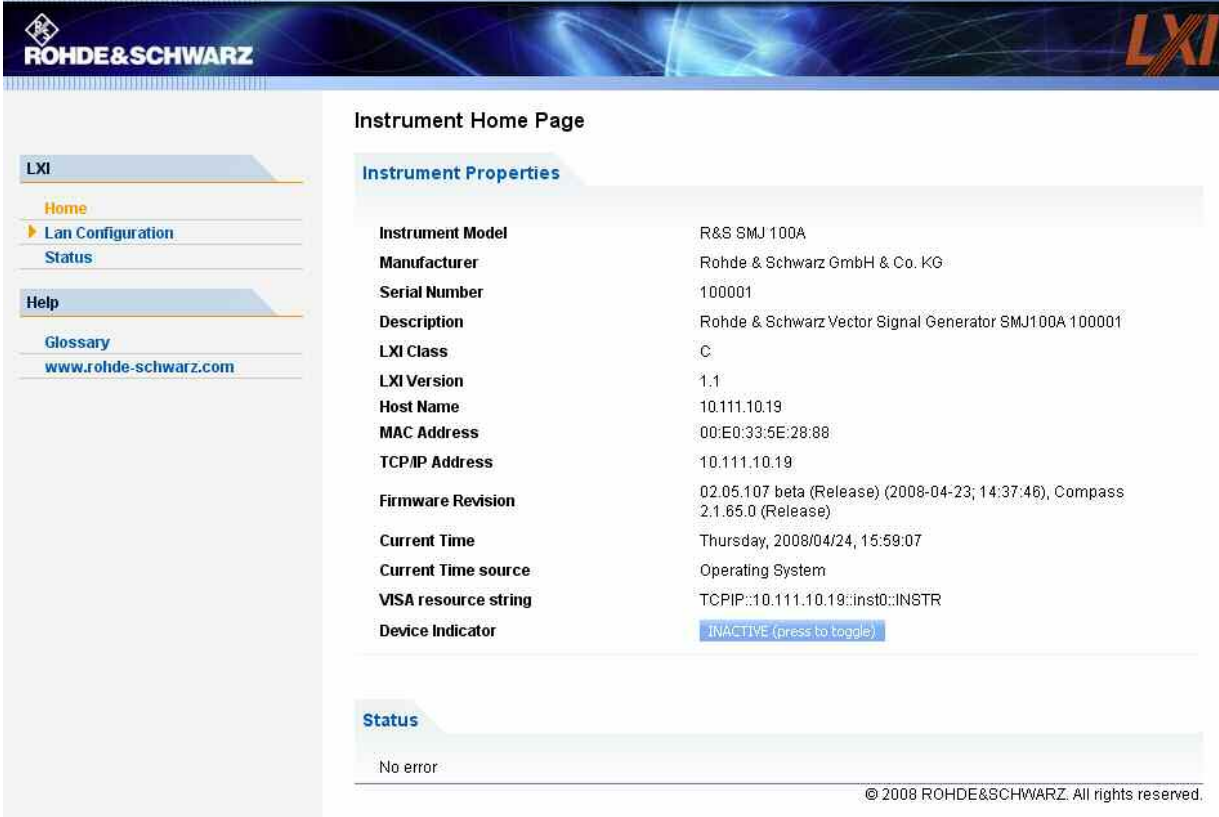

The screenshot displays the LXI browser interface for an R&S SMJ100A instrument. The interface includes a navigation menu on the left and a main content area with the following sections:

- Instrument Home Page**
  - Instrument Properties**

Instrument Model	R&S SMJ 100A
Manufacturer	Rohde & Schwarz GmbH & Co. KG
Serial Number	100001
Description	Rohde & Schwarz Vector Signal Generator SMJ100A 100001
LXI Class	C
LXI Version	1.1
Host Name	10.111.10.19
MAC Address	00:E0:33:5E:28:88
TCP/IP Address	10.111.10.19
Firmware Revision	02.05.107 beta (Release) (2008-04-23; 14:37:46), Compass 2.1.65.0 (Release)
Current Time	Thursday, 2008/04/24, 15:59:07
Current Time source	Operating System
VISA resource string	TCP/IP::10.111.10.19::inst0::INSTR
Device Indicator	<input type="button" value="INACTIVE (press to toggle)"/>
  - Status**

No error

© 2008 ROHDE&SCHWARZ. All rights reserved.

**Instrument Home Page - LXI Browser Interface** The instrument home page displays the device information required by the LXI standard including the VISA resource string in read-only format.

Pressing the button **Inactive (press to toggle)** button causes a LAN Status indicator on the instrument's home page to flash (if active).

ACTIVE (press to toggle)



A green LXI status symbol on the instrument's home page indicates that a LAN connection has been established; a red LED indicates that no LAN cable is connected.

The status of the LAN connection is also indicated by the LAN Status indicator in the LXI Status dialogbox.

For further information, see chapter 4, section "[LXI Status - Setup-Remote](#)".

The **Device Indicator** setting is not password-protected.

**LAN Configuration - LXI Browser Interface** Opens the **LAN Configuration** page.

**Status - LXI Browser Interface** Displays information about the LXI status of the instrument.

**LXI Glossary - LXI Browser Interface** Opens a document with a glossary of terms related to the LXI standard.

## LAN Configuration - LXI Browser Interface

The **LAN Configuration** web page displays all mandatory LAN parameters and allows their modification.

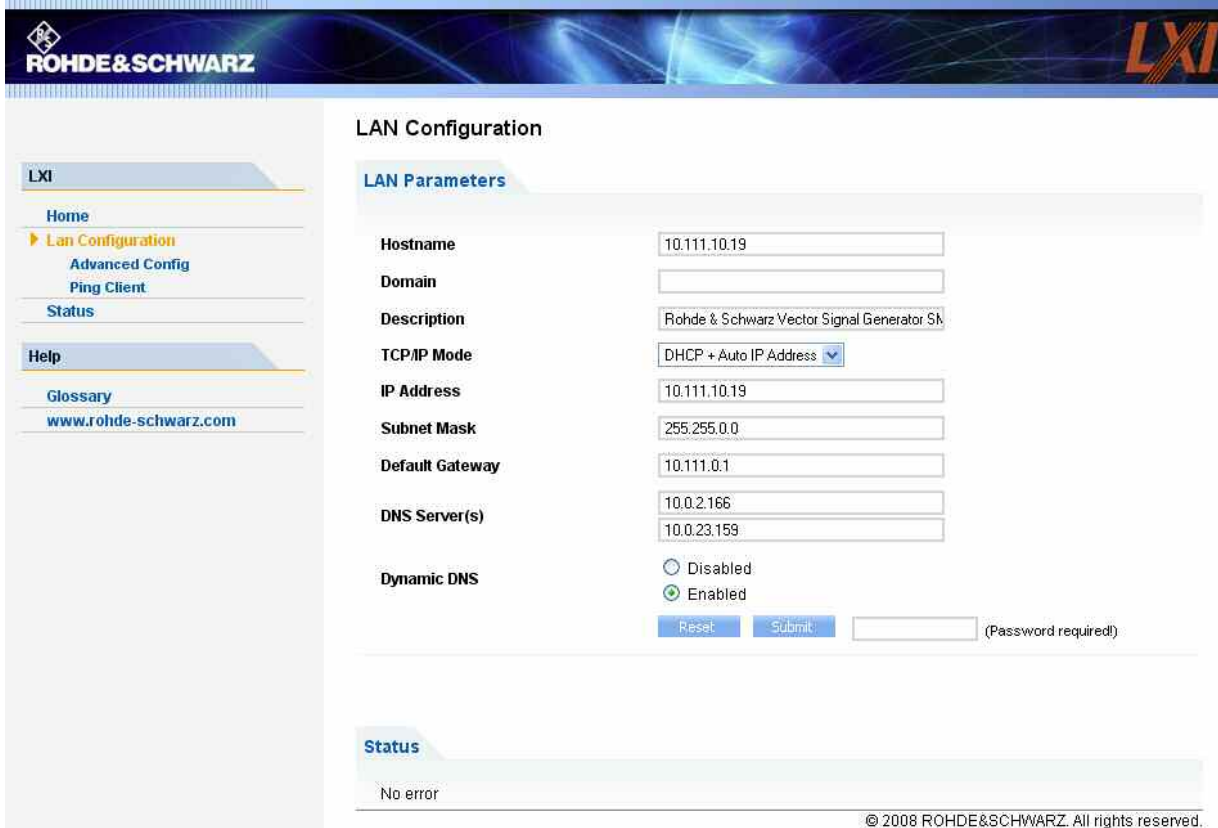

**LAN Configuration**

**LAN Parameters**

Hostname: 10.111.10.19

Domain:

Description: Rohde & Schwarz Vector Signal Generator S

TCP/IP Mode: DHCP + Auto IP Address

IP Address: 10.111.10.19

Subnet Mask: 255.255.0.0

Default Gateway: 10.111.0.1

DNS Server(s): 10.0.2.166  
10.0.23.159

Dynamic DNS:  Disabled  Enabled

Reset Submit (Password required!)

**Status**

No error

© 2008 ROHDE&SCHWARZ. All rights reserved.

## TCP/IP Mode - LXI Browser Interface

Controls how the IP address for the instrument gets assigned.

### Note:

*Changing the LAN configuration is password-protected. The password reads `LxiWebIfc` (notice upper and lower case characters).*

*This password cannot be changed in the current firmware version.*

In **Static IP Address** configuration mode, the static IP address, subnet mask, and default gateway are used to configure the LAN.

The automatic configuration mode (**DHCP + Auto IP Address**) uses DHCP server or Dynamic Link Local Addressing (Automatic IP) to obtain the instrument IP address.

## Advanced Configuration - LXI Browser Interface

**Advanced Configuration** menu provides LAN settings that are not declared mandatory by the LXI standard.

### Negotiation - LXI Browser Interface

Provides different Ethernet speed and duplex mode settings. In general, the *Auto Detect* mode is sufficient.

### ICMP Ping - LXI Browser Interface

Enables/disables the ping. The parameter must be enabled to use the ping utility.

### VXI-11 Discovery - LXI Browser Interface

VXI-11 is the protocol that is used for discovery of the instrument in the LAN. According to the standard, LXI devices must use VXI-11 to provide a discovery mechanism; other additional discovery mechanisms are permitted.

## Ping - LXI Browser Interface

Ping is a utility that verifies the connection between the LXI-compliant instrument and another device. The ping command uses the ICMP echo request and echo reply packets to determine whether the LAN connection is functional. Ping is useful for diagnosing IP network or router failures.

The ping utility is not password-protected. To initiate a ping between the LXI-compliant instrument and a second connected device,

1. Enable **ICMP Ping** on the **Advanced LAN Configuration** page (enabled after an LAN Reset).
2. Enter the IP address of the second device without the ping command and without any further parameters into the **Destination Address** field (e.g. *10.111.10.19*).
3. Click **Submit**.



## Remote Control via USB Interface

The PC and the instrument must be connected via the USB type B interface. An USB connection requires the VISA library to be installed. VISA will detect and configure the generator automatically when the USB connection is established. No entry of an address string and no separate driver installation is necessary.

The used USB address string is:

USB::::<product Id>::::INSTR

### Example:

"USB::0x0AAD::0x0046::100001::INSTR", where:

the first block 0x0AAD is the vendor Id for Rohde&Schwarz,

the second block is the product Id for the R&S Signal Generator

and the third block is the individual serial number on the rear panel of the instrument.



## Interface and Device Messages

The messages transferred via the data lines of the IEC/IEEE-bus (see chapter 8, section "[IEC/IEEE Bus Interface](#)") or via a TCP/IP network can be divided into two groups:

- - interface messages and
- - device messages.

### Interface Messages

Interface messages are transferred on the data lines of the IEC/IEEE bus, the ATN control line being active. They are used for communication between controller and instrument and can only be sent by a computer which has the function of an IEC/IEEE bus controller.

Interface commands can be further subdivided into

- **universal commands**
- **addressed commands**

Universal commands act on all devices connected to the IEC/IEEE-bus without previous addressing, addressed commands only act on devices previously addressed as listeners. The interface messages relevant to the instrument are listed in chapter 8, section "[IEC/IEEE Bus Interface](#)".

If an Ethernet connection is present, signalling via a hardware control line is not required. The IEC/IEEE-bus interface commands are emulated (see chapter 8, section "[LAN Connector](#)").

### Device Messages (Commands and Device Responses)

Device messages are transferred on the data lines of the IEC/IEEE-bus, the "ATN" control line not being active. ASCII character set is used.

If an Ethernet connection is present, signalling via a hardware control line is not required.

The device messages are equal for the different interfaces (IEC/IEEE bus and Ethernet). A distinction is made according to the direction in which they are sent:

**Commands** (Program Messages) are messages the controller sends to the instrument. They operate the device functions and request information.

The commands are subdivided according to two criteria:

1. According to the effect they have on the instrument:

**Setting commands** cause instrument settings such as a reset of the instrument or setting the frequency.

**Queries** cause data to be provided for output on the IEC/IEEE bus, e.g. for identification of the device or polling a parameter value. Queries are formed by directly appending a question mark to the header.



2. According to their definition in standard IEEE 488.2 and SCPI:

**Common commands** are exactly defined as to their function and notation in standard IEEE 488.2. They refer to functions such as management of the standardized status registers, reset and selftest.

**Instrument control commands** refer to functions depending on the features of the instrument such as frequency setting. A majority of these commands has also been standardized by the SCPI committee. Device-specific extensions following the SCPI rules are permitted by the standard.

**Device responses** (Response Messages and Service Request) are messages the instrument sends to the controller after a query. They can contain measurement results, instrument settings and information on the instrument status (cf. section "[Responses to Queries](#)", page 5.21).

Structure and syntax of the device messages are described in the following section.

# SCPI Command Structure and Syntax

The commands consist of a so-called header and, in most cases, one or more parameters. The header and parameter are separated by a "white space" (ASCII code 0 to 9, 11 to 32 decimal, e.g. blank). The headers may consist of several key words. Queries are formed by directly appending a question mark to the header.

**Note:**

*The commands used in the following examples are not in every case implemented in the instrument.*

**Common Commands** Common commands consist of a header preceded by an asterisk "\*" and one or more parameters, if any.

- Examples:**
- \*RST            RESET, resets the device
  - \*ESE 253        EVENT STATUS ENABLE, sets the bits of the event status enable register
  - \*ESR?            EVENT STATUS QUERY, queries the contents of the event status register.

**Instrument control commands**

Hierarchy: Instrument control commands are of hierarchical structure (see figure below). The different levels are represented by combined headers. Headers of the highest level (root level) have only one key word. This key word denotes a complete command system

**Example:** :SOURce

This key word denotes the command system SOURce.

For commands of lower levels, the complete path has to be specified, starting on the left with the highest level, the individual key words being separated by a colon ":".

**Example:** SOURce:BB:DM:FORMat QPSK  
'selects the QPSK format for of digital modulation.

This command lies in the fourth level of the SOURce.

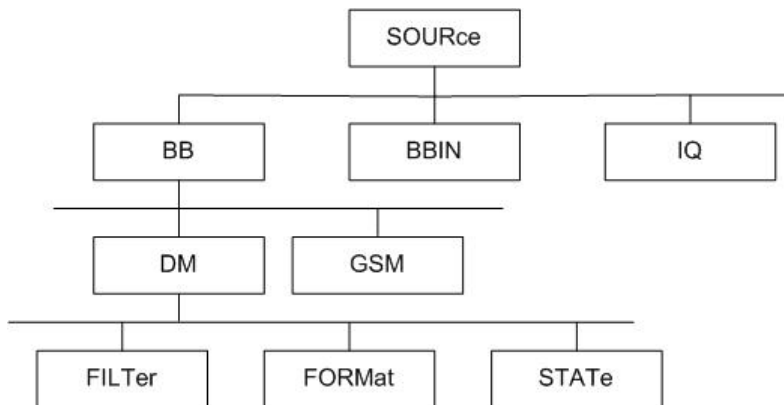

Figure 5-1 Example for the tree structure of the SCPI command systems; the SOURce system

**Multiple key words** Some key words occur on several levels within one command system. Their effect depends on the structure of the command, i. e. on the position in the command header they are inserted in.

**Example:** `SOURce:BB:DM:STATe ON`

This command contains key word `STATe` in the fourth command level. It switches digital modulation on.

`SOURce:BB:DM:PRAMp:STATe ON`

This command contains key word `STATe` in the fifth command level. It switches power ramping on.

**Optional key words:** Some command systems permit certain key words to be optionally inserted into the header or omitted. These key words are marked by square brackets in this manual. The full command length must be recognized by the instrument for reasons of compatibility with the SCPI standard. Some commands are considerably shortened by omitting optional key words.

**Example:** `[SOURce:]BB:DM:PRAMp[:STATe] ON`

This command switches power ramping on. The following command has the same effect:

`BB:DM:PRAMp ON`

---

**Note:**

*An optional key word must not be omitted if its effect is specified in detail by a numeric suffix. In the R&S Signal Generator, this for instance applies to the keyword `SOURce` which can be omitted for path A = `SOURce1` but must be specified for path B = `SOURce2`.*

---

**Long and short form:** The key words feature a long form and a short form. Either the short form or the long form can be entered, other abbreviations are not permitted.

**Example:** `STATus:QUEStionable:ENABle 1`  $\equiv$  `STAT:QUES:ENAB 1`

---

**Note:**

*Upper-case and lower-case notation only serves to distinguish the two forms in the manual, the instrument itself does not distinguish upper-case and lower-case letters.*

---

**Parameters:** Parameters must be separated from the header by a "white space". If several parameters are specified in a command, they are separated by a comma ",". A few queries permit the parameters `MINimum`, `MAXimum` and `DEFault` to be entered. For a description of the types of parameter, refer to section [Parameters](#), page 5.21 .

**Example:** `SOURce:IQ:OUTPut:BIAS:Q? MAXimum`

Response: 2.7

This query requests the maximal value (2.7 V) for the amplifier bias of the Q signal component.

**Numeric suffix:** If a device features several functions or features of the same kind, e.g. several inputs, the desired function can be selected by a suffix added to the command. Entries without suffix are interpreted like entries with the suffix 1. Optional keywords must be specified if they select a function with the suffix.

**Example:** `SOURce2:BB:DM:STATe ON`

This command activates digital modulation for path B. The keyword `SOURce` must be specified in the command. For path A, the keyword is optional and can be omitted.

---

**Note:**

*In case of remote control, suffix counting may differ from the numbers of the corresponding selection used in manual operation. SCPI prescribes that suffix counting starts with 1. Suffix 1 is the default state and used when no specific suffix is specified.*

*Some standards define a fixed numbering, starting with 0. With GSM, for instance, slots are counted from 0 to 7. In the case of remote control, the slots are selected with the suffixes 1 to 8.*

*If the numbering differs in manual operation and remote control, it is indicated with the respective command.*

---

## Structure of a Command Line

A command line may consist of one or several commands. It is terminated by an EOI together with the last data byte.

Several commands in a command line must be separated by a semicolon ";". If the next command belongs to a different command system, the semicolon is followed by a colon ":". A colon ":" at the beginning of a command marks the root node of the command tree.

**Example:** `":SOURce:BB:IMPairment:IQRatio 4PCT; :SOURce:IQ:OUTPut:TYPE DIFF"`

This command line contains two commands. The first command is part of the `IMPairment` system and is used to set the imbalance for the digital I/Q channels. The second command is part of the `OUTPut` system and sets the analog output type to `DIFFerential`.

If the successive commands belong to the same system, having one or several levels in common, the command line can be abbreviated. To this end, the second command after the semicolon starts with the level that lies below the common levels (see also [Figure 0-1](#)). The colon following the semicolon must be omitted in this case.

**Example:** `"SOURce:BB:IMP:IQRatio 4PCT;:SOURce:BB:IMP:STATe ON"`

This command line is represented in its full length and contains two commands separated from each other by the semicolon. Both commands are part of the `SOURce` command system, subsystem `BB` and subsystem `IMPairment`, i.e. they have three common levels. The first command sets the imbalance for the digital I/Q channels. The second command enables the impairment values.

When abbreviating the command line, the second command begins with the level below `SOURce:BB:IMPairment`. The colon after the semicolon is omitted.

The abbreviated form of the command line reads as follows:

`"SOURce:BB:IMP:IQRatio 4PCT; STATe ON"`

## Responses to Queries

A query is defined for each setting command unless explicitly specified otherwise. It is formed by adding a question mark to the associated setting command. According to SCPI, the responses to queries are partly subject to stricter rules than in standard IEEE 488.2.

1. The requested parameter value is transmitted without command header.

**Example:** "SOURCE:BB:DM:FORMat?" Answer: BPSK

2. Maximum values, minimum values and all further quantities, which are requested via a special text parameter are returned as numerical values

**Example:** "SOURCE:IQ:OUTPut:BIAS:Q? MAXimum" Answer: 2.7

3. Boolean values are returned as 0 (for OFF) and 1 (for ON).

**Example:** "SOURCE:IQ:OUTPut:STATE?" Answer (for ON): ON or 1

4. Text (character data) is returned in a short form

**Example:** "SOURCE:BB:DM:FILTer:TYPE?" Answer (for COSine): COS

## Parameters

Most commands require a parameter to be specified. The parameters must be separated from the header by a "white space". Permissible parameters are numerical values, Boolean parameters, text, character strings and block data. The type of parameter required for the respective command and the permissible range of values are specified in the command description.

**Numerical values** Numerical values can be entered in any form, i.e. with sign, decimal point and exponent. Values exceeding the resolution of the instrument are rounded up or down. The mantissa may comprise up to 255 characters, the values must be in the value range  $-9.9E37$  to  $9.9E37$ . The exponent is introduced by an "E" or "e". Entry of the exponent alone is not allowed.

**Units** In the case of physical quantities, the unit can be entered. Permissible unit prefixes are G (giga), MA (mega), MOHM and MHZ (also permissible), K (kilo), M (milli), U (micro) and N (nano). If the unit is missing, the basic unit is used.

**Example:**

SOUR:BB:MCCW:CARR:SPAC 1MHZ = SOUR:BB:MCCW:CARR:SPAC 1E6

Some settings allow relative values to be stated in percent. According to SCPI, this unit is represented by the PCT string.

**Example:**

:SOURCE:BB:IMPairment:IQRatio 4PCT

**Special numeric values** The texts MINimum, MAXimum, DEFault, UP and DOWN are interpreted as special numerical values.

In the case of a query, the associated numerical value is provided.

**Example:**

Setting command:

:SOURCE:IQ:OUTPut:BIAS:Q MAXimum

Query:

:SOURCE:IQ:OUTPut:BIAS:Q? Answer: 2.7

MIN/MAX	MINimum and MAXimum denote the minimum and maximum value
DEF	DEFault denotes a preset value. This value conforms to the default setting, as it is called by the *RST command.
UP/DOWN	UP, DOWN increases or reduces the numerical value by one step. The step width can be specified via an allocated step command for each parameter which can be set via UP, DOWN.
INF/NINF	INFinity, Negative INFinity (NINF) represent the numerical values -9.9E37 or 9.9E37, respectively. INF and NINF are only sent as device responses.
NAN	Not A Number (NAN) represents the value 9.91E37. NAN is only sent as device response. This value is not defined. Possible causes are division by zero, subtraction or addition of infinite and the representation of missing values.

**Boolean Parameters** Boolean parameters represent two states. The ON state (logically true) is represented by ON or a numerical value unequal to 0. The OFF state (logically untrue) is represented by OFF or the numerical value 0. ON or OFF is returned by a query.

**Example:**

Setting command:

:SOURce:IQ:OUTPut:STATE ON

Query:

:SOURce:IQ:OUTPut:STATE? Answer: 1

**Text** Text parameters observe the syntax rules for key words, i.e. they can be entered using a short or long form. Like any parameter, they have to be separated from the header by a white space. In the case of a query, the short form of the text is provided.

**Example:**

Setting command:

:SOURce:BB:DM:CLOCK:MODE SYMBOL

Query:

:SOURce:BB:DM:CLOCK:MODE? Answer: SYMB

**Strings** Strings must always be entered within quotation marks (' or ").

**Example:**

```
DIAGnostic:MEASure:POINT?      'DIAG_UNICOD_INT_ROUT' or
                                "DIAG_UNICOD_INT_ROUT"
```

**Block data** Block data are a transmission format which is suitable for the transmission of large amounts of data. A command using a block data parameter with definite length has the following structure:

**Example:** MMEMemory:DATA test\_file.wv, #45168xxxxxxxx

Test\_file.wv denotes the name of the file to which the data are written. The comma is followed by the binary data block. The hash symbol # introduces the data block. The next number indicates how many of the following digits describe the length of the data block. In the example the 4 following digits indicate the length to be 5168 bytes. The data bytes follow. During the transmission of these data bytes all End or other control signs are ignored until all bytes are transmitted.

The format of the binary files within the block depends on the IEC/IEEE-bus command

SOURce:LIST:FREQuency|:POWer (R&S SMx only)

SOURce:CORRection:CSET:DATA:FREQuency|:POWer (R&S SMx only)

SOURce:BB:MCCW:CARRier:LIST:PHASe |:POWer

use the IEEE-754 format for double precision floating point numbers. Each number is represented by 8 bytes.

**Example:**

a# = 125.345678E6

b# = 127.876543E6

```
CALL IBWRT(generator%, "SOURce:BB:MCCW:CARRier:LIST:PHASe
#216" + MKD$(a#) + MKD$(b#))
```

- #' in the command string introduces the binary block,
- 2' indicates that 2 digits specifying the length will follow next,
- 16' is the length of the binary block (in bytes), here: 2 double precision floating point number with 8 bytes each.
- The actual binary data follow now. As the function IBWRT requires a text string, MKD\$ is used for the type conversion.

The following ASCII format has the same effect:

```
CALL IBWRT(generator%, "SOURce:BB:MCCW:CARRier:LIST:PHASe
125.345678E6, 127.876543E6")
```

## Overview of Syntax Elements

The following survey offers an overview of the syntax elements.

- : The colon separates the key words of a command. In a command line the separating semicolon marks the uppermost command level.
- ; The semicolon separates two commands of a command line. It does not alter the path.
- , The comma separates several parameters of a command.
- ? The question mark forms a query.
- \* The asterisk marks a common command.
- " Quotation marks introduce a string and terminate it.
- # The hash symbol # introduces binary, octal, hexadecimal and block data.

Binary: #B10110

Octal: #O7612

Hexa: #HF3A7

Block: #21312

A "white space" (ASCII-Code 0 to 9, 11 to 32 decimal, e.g. blank) separates header and parameter.

## Instrument Model and Command Processing

The block diagram in the figure below shows how SCPI commands are serviced in the instrument. The individual components work independently and simultaneously. They communicate with each other by means of so-called "messages".

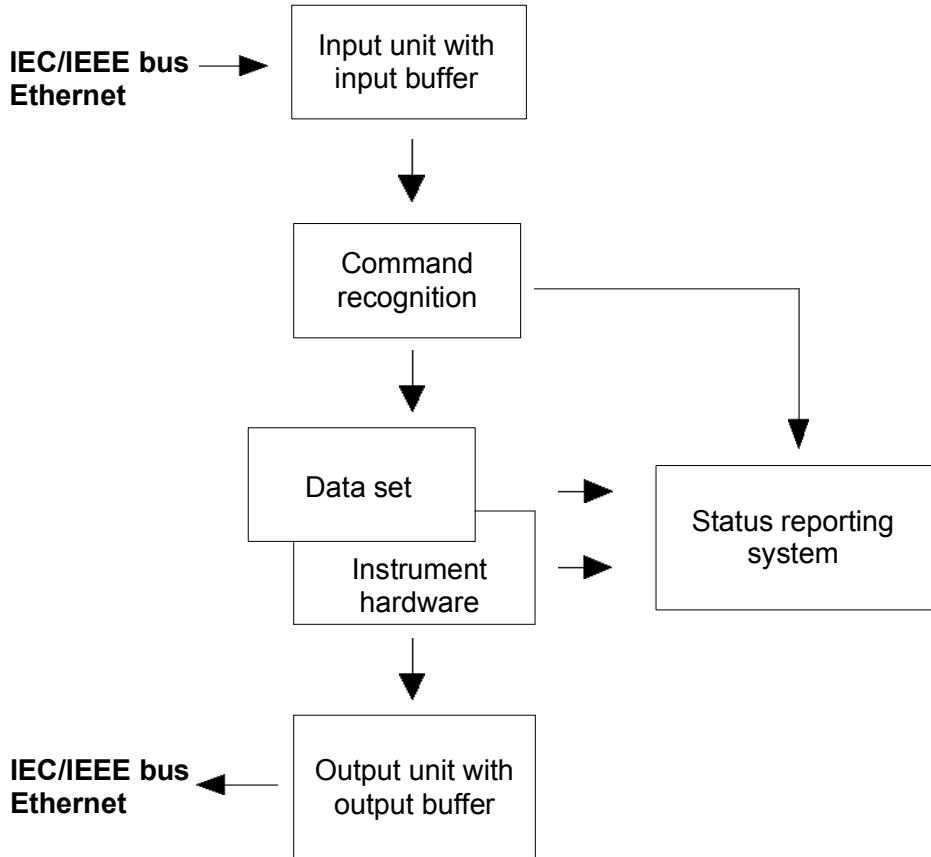

Figure 5-2 Instrument model in the case of remote control via IEC/IEEE bus or TCP/IP network

### Input Unit

The input unit receives commands character by character from the IEC/IEEE bus or via the Ethernet and collects them in the input buffer. The input unit sends a message to the command recognition as soon as the input buffer is full or as soon as it receives a delimiter, <PROGRAM MESSAGE TERMINATOR>, as defined in IEEE 488.2, or the interface message DCL.

If the input buffer is full, the traffic is stopped and the data received up to then is processed. Subsequently the traffic is continued. If, however, the buffer is not yet full when receiving the delimiter, the input unit can already receive the next command during command recognition and execution. The receipt of a DCL clears the input buffer and immediately initiates a message to the command recognition.



## Command Recognition

The command recognition analyses the data received from the input unit. It proceeds in the order in which it receives the data. Only a DCL is serviced with priority, a GET (Group Execute Trigger), e.g., is only executed after the commands received before. Each recognized command is immediately transmitted to the data set but not executed immediately.

The command recognition detects syntax errors in the commands and transfers them to the status reporting system. The rest of a command line after a syntax error is analyzed further if possible and serviced. After the syntax test, the value range of the parameter is checked, if required.

If the command recognition detects a delimiter or a DCL, it also requests the data set to perform the necessary instrument hardware settings. Subsequently it is immediately prepared to process further commands. This means that new commands can already be serviced while the hardware is still being set ("overlapping execution").

## Data Base and Instrument Hardware

The expression "instrument hardware" denotes the part of the instrument fulfilling the actual instrument function - signal generation etc. The controller is not included. The term "database" denotes a database that manages all the parameters and associated settings required for setting the instrument hardware. Setting commands lead to an alteration in the data set. The data set management enters the new values (e.g. power) into the data set, however, only passes them on to the hardware when requested by the command recognition. As this is only ever effected at the end of a command line, the order of the setting commands in the command line is not relevant.

The data are only checked for their compatibility among each other and with the instrument hardware immediately before they are transmitted to the instrument hardware. If the detection is made that execution is not possible, an "execution error" is signaled to the status reporting system. All alterations of the data set are canceled, the instrument hardware is not reset. Due to the delayed checking and hardware setting, however, impermissible instrument states can be set for a short period of time within one command line without this leading to an error message. At the end of the command line, however, a permissible instrument state must have been reached again.

### Example:

With **Custom Digital Modulation**, the settable FSK deviation depends on the set symbol rate (in case of FSK modulation). The R&S Signal Generator responds as follows:

Assuming the set symbol rate is 100 ksymb/s, i.e. the permissible value range for FSK deviation is 1 kHz to 150 kHz. A deviation of 300 kHz should be set. To do so, the symbol rate has to be changed to 150 ksymb/s. The following commands are sent:

1. All commands in one program message:

```
:SOUR:BB:DM:FORM FSK2; :SOUR:BB:DM:FSK:DEV 300kHz; :SOUR:BB:DM:SRAT  
150kHz
```

This command line yields the desired setting. Since a valid state is obtained at the end of the program message, no error message is issued.

2. Each command in a separate program message:

```
:SOUR:BB:DM:FORM FSK2
:SOUR:BB:DM:FSK:DEV 300kHz
:SOUR:BB:DM:SRAT 150kHz
```

The command for setting the FSK deviation is rejected and an execution error is generated. At the time when this command is processed, the previous setting of the symbol rate (100 ksymb) is still valid, i.e. the value for the FSK deviation is outside the permissible value range. The two other commands are set.

3. The two first commands in one program message, the third command in a separate program message.

```
:SOUR:BB:DM:FORM FSK2; :SOUR:BB:DM:FSK:DEV 300kHz
:SOUR:BB:DM:SRAT 150kHz
```

The command for setting the FSK deviation is rejected and an execution error is generated. At the time when this command is processed, the previous setting of the symbol rate (100 ksymb) is still valid, i.e. the value for the FSK deviation is outside the permissible value range. The two other commands are executed.

This example shows that it is advisable to send interdependent commands in one program message as in this case the sequence in which they are sent is irrelevant.

For further examples on command sequence see section "[Command Sequence and Command Synchronization](#)", on page 5.27.

Before passing on the data to the hardware, the settling bit in the `STATUS:OPERation` register is set (see section [Status Reporting System](#), page 5.30. The hardware executes the settings and resets the bit again as soon as the new state has settled. This fact can be used to synchronize command servicing.

Queries induce the data set management to send the desired data to the output unit.

## Status Reporting System

The status reporting system collects information on the instrument state and makes it available to the output unit on request. The exact structure and function are described in section "[Status Reporting System](#)", page 5.30.

## Output Unit

The output unit collects the information requested by the controller, which it receives from the data set management. It processes it according to the SCPI rules and makes it available in the output buffer. If the instrument is addressed as a talker without the output buffer containing data or awaiting data from the data set management, the output unit sends the error message "Query UNTERMINATED" to the status reporting system. No data are sent on the IEC/IEEE bus or via the Ethernet, the controller waits until it has reached its time limit. This behavior is specified by SCPI.

## Command Sequence and Command Synchronization

IEEE 488.2 defines a distinction between overlapped and sequential commands:

- ◆ An overlapped command is one which does not automatically finish executing before the next command starts executing. Overlapped commands allow the program to do other tasks while being executed.
- ◆ A sequential command is one which always finishes before the next command starts executing. Sequential commands are not implemented in the generator, however the execution time of most commands is so short that they act as sequential commands when sent in different command lines.

If a particular device action can be performed only after the execution of a previous overlapped command, the controller must know when the overlapped command has finished. The necessary interaction between the controller and the test instrument is called command synchronization.

### Example 1: Overlapped command followed by non-conflicting commands

Suppose that the generator is switched on to provide a real time test signal that requires some calculation time. At the same time some settings for the configuration of a different signal are made which do not interact with the generated signal (e.g. the signal may be used later on).

The signal generation and the signal configuration are independent from each other, so none of the following overlapped commands needs to be synchronized:

```
SOURce:BB:3GPP:STAT ON
SOURce:BB:GSM:FORMat FSK2
```

### Example 2: Overlapped command followed by conflicting commands

Suppose that the generator is switched on to provide a real time test signal that requires some calculation time. This signal is to be added to a waveform from the second baseband generator. In this case the application program must ensure that the real signal is actually available in the added signal before further action is started. This involves an appropriate synchronization technique for the first command (the following ssequence assumes an appropriate routing):

```
SOURce:BB:3GPP:STAT ON
<Wait until command has finished>
SOURce2:BB:GSM:STATe ON
```

Depending on the selected synchronization techniques, non-conflicting commands can be executed while waiting until the synchronized overlapped command has finished.

## Command Sequence

According to section "*Data Base and Instrument Hardware*", overlapped execution is possible in principle for all commands of the signal generator. Equally, setting commands within one command line are not necessarily serviced in the order in which they have been received. In order to make sure that commands are actually carried out in a certain order, each command must be sent in a separate command line (see also example in section "[Data Base and Instrument Hardware](#)", on page 5.25).

**Example 1: Commands and queries in one command line**

The response from a query combined in a program message with commands that affect the queried value is not predictable. Sending

```
SOURce:BB:GSM:MODE DOUBle; FRAMe2:REPetitions 20
```

```
SOURce:BB:GSM:FRAMe2:REPetitions?
```

```
always returns 20. When:SOURce:BB:GSM:MODE DOUBle; FRAMe2:REPetitions 20;
FRAMe2:REPetitions?
```

is sent, however, the result is not specified by SCPI. The result could be the RF generator frequency before the command was sent since the instrument might defer executing the individual commands until a program message terminator is received. The result could also be 1GHz if the instrument executes commands as they are received.

As a general rule, send commands and queries in different program messages.

**Example 2: Overlapped command with \*OPC in one command line**

Assuming that `SOURce:BB:3GPP:STAT ON` takes longer to execute than `*OPC`, sending the command sequence

```
SOURce:BB:W3GPP:STAT ON; *OPC?
```

results in initiating the calculation of the 3GPP signal and, and after the calculation is finished, setting the OPC bit in the ESR.

Sending the commands:

```
SOURce:BB:W3GPP:STAT ON; *OPC?; CLS
```

still the calculation of the 3GPP signal. Since the calculation may not yet be finished when the signal generator executes `*CLS`, `*OPC` can be effectively skipped. In this case the OPC bit is not set until the signal generator executes another `*OPC` command.

As a general rule, avoid sending commands with reverse action in a single command line.

**Command Synchronization**

In order to prevent an overlapping execution of commands, one of commands `*OPC`, `*OPC?` or `*WAI` must be used. All three commands cause a certain action only to be carried out after the hardware has been set and has settled. By suitable programming, the controller can be forced to wait for the respective action to occur (see table).

*Table 5-1 Synchronization with \*OPC, \*OPC? and \*WAI*

Command	Action	Programming the controller
*OPC	Sets the Operation Complete bit in the ESR after all previous commands have been executed.	- Setting bit 0 in the ESE - Setting bit 5 in the SRE - Waiting for service request (SRQ)
*OPC?	Stops command processing until 1 is returned. This is only the case after the Operation Complete bit has been set in the ESR. This bit indicates that the previous setting has been completed.	Sending *OPC? directly after the command whose processing should be terminated before other commands can be executed. Disabling bit 4 (MAV) of the SRE register. <b>Alternative:</b> Service request or timeout method with enabled MAV bit; see below.
*WAI	Stops further command processing until all commands sent before *WAI have been executed.	Sending *WAI directly after the command whose processing should be terminated before other commands are executed.

Command synchronization by means of a \*WAI or \*OPC? appended to an overlapped command is a good choice if the overlapped command takes only little time to process. The two synchronization techniques simply block overlapped execution of the command.

For time consuming overlapped commands it is usually desirable to allow the controller or the R&S signal generator to do other useful work while waiting for command execution. Use one of the following methods:

#### **\*OPC with a service request**

1. Set the OPC mask bit (bit no. 0) in the ESE: \*ESE 1
2. Set bit no. 5 in the SRE: \*SRE 32 to enable ESB service request.
3. Send the overlapped command with \*OPC
4. Wait for a service request

The service request indicates that the overlapped command has finished.

#### **\*OPC? with a service request**

1. Set bit no. 4 in the SRE: \*SRE 16 to enable MAV service request.
2. Send the overlapped command with \*OPC?
3. Wait for a service request

The service request indicates that the overlapped command has finished.

#### **Event Status Register (ESE)**

1. Set the OPC mask bit (bit no. 0) in the ESE: \*ESE 1
2. Send the overlapped command without \*OPC, \*OPC? or \*WAI
3. Poll the operation complete state periodically (by means of a timer) using the sequence: \*OPC; \*ESR?

A return value (LSB) of 1 indicates that the overlapped command has finished.

#### **\*OPC? with short timeout**

1. Send the overlapped command without \*OPC, \*OPC? or \*WAI
2. Poll the operation complete state periodically (by means of a timer) using the sequence: <short timeout>; \*OPC?

A return value (LSB) of 1 indicates that the overlapped command has finished. In case of a timeout, the operation is ongoing.

3. Reset timeout to former value
4. Clear the error queue with SYStem:ERRor? to remove the "-410, Query interrupted" entries.

#### **Using several threads in the controller application**

As an alternative, provided the programming environment of the controller application supports threads, separate threads can be used for the application GUI and for controlling the instrument(s) via SCPI.

A thread waiting for a \*OPC? thus will not block the GUI or the communication with other instruments.

# Status Reporting System

The status reporting system stores information on errors which have occurred. This information is stored in the error queue. The error queue can be queried via IEC/IEEE bus or via the Ethernet. The information is of a hierarchical structure. The register status byte (STB) defined in IEEE 488.2 and its associated mask register service request enable (SRE) form the uppermost level. The STB receives its information from the standard event status register (ESR) which is also defined in IEEE 488.2 with the associated mask register standard event status enable (ESE) and registers. The IST flag ("Individual Status") and the parallel poll enable register (PPE) allocated to it are also part of the status reporting system. The IST flag, like the SRQ, combines the entire instrument status in a single bit. The PPE fulfills an analog function for the IST flag as the SRE for the service request. The output buffer contains the messages the instrument returns to the controller. It is not part of the status reporting system but determines the value of the MAV bit in the STB. The output buffer contains the messages the instrument returns to the controller. It is not part of the status reporting system but determines the value of the MAV bit in the STB.

## Overview of the Status Register

The following figure shows the status registers used in the R&S Signal Generator.

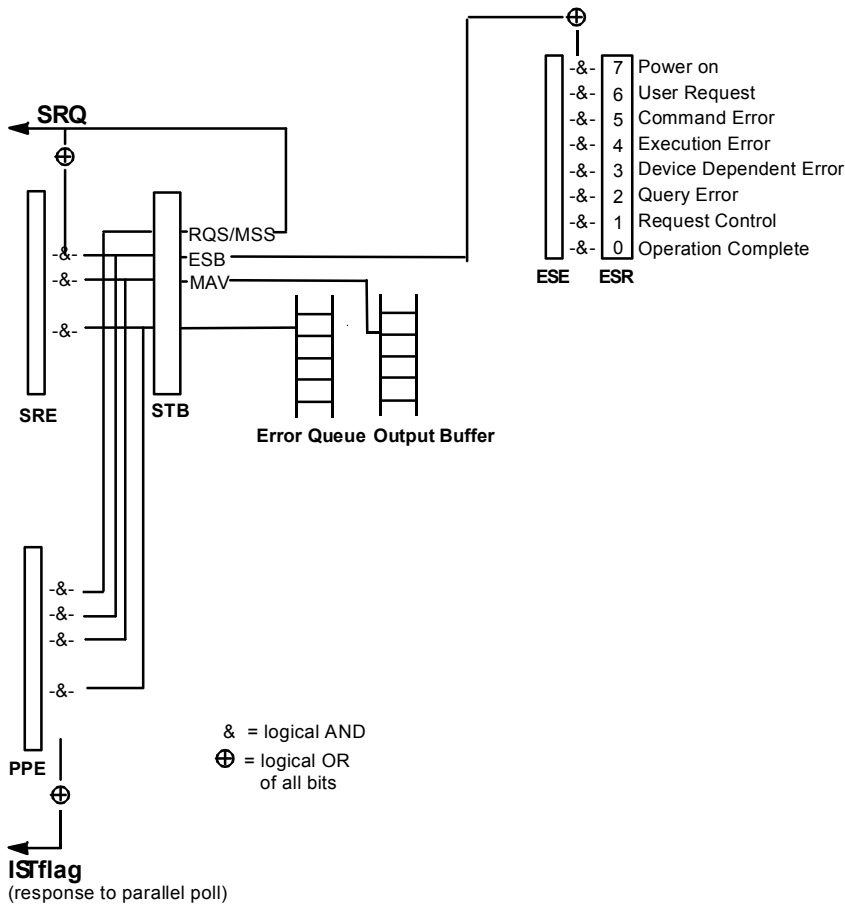

Figure 5-3 Overview of status registers

## Status Byte (STB) and Service Request Enable Register (SRE)

The STB is already defined in IEEE 488.2. It provides a rough overview of the instrument status by collecting the pieces of information of the lower registers. A special feature is that bit 6 acts as the sum bit of the remaining bits of the status byte.

The STATUS BYTE is read out using the command `"*STB?"` or a serial poll.

The STB is linked to the SRE. Each bit of the STB is assigned a bit in the SRE. Bit 6 of the SRE is ignored. If a bit is set in the SRE and the associated bit in the STB changes from 0 to 1, a Service Request (SRQ) is generated on the IEC/IEEE bus or via the Ethernet, which triggers an interrupt in the controller if this is appropriately configured and can be further processed there.

The SRE can be set using command `"*SRE"` and read using `"*SRE?"`.

Table 5-2 Meaning of the bits used in the status byte

Bit no.	Meaning
0...1	Not used
2	Error Queue not empty The bit is set when an entry is made in the error queue. If this bit is enabled by the SRE, each entry of the error queue generates a Service Request. Thus an error can be recognized and specified in greater detail by polling the error queue. The poll provides an informative error message. This procedure is to be recommended since it considerably reduces the problems involved with Remote control.
3	Not used
4	<b>MAV bit</b> (Message available) The bit is set if a message is available in the output buffer which can be read. This bit can be used to enable data to be automatically read from the instrument to the controller.
5	ESB bit Sum bit of the event status register. It is set if one of the bits in the event status register is set and enabled in the event status enable register. Setting of this bit indicates a serious error which can be specified in greater detail by polling the event status register.
6	<b>MSS bit</b> (Master-Status-Summary-Bit) The bit is set if the instrument triggers a service request. This is the case if one of the other bits of this register is set together with its mask bit in the service request enable register SRE.
7	Not used

## IST-Flag and Parallel Poll Enable Register (PPE)

By analogy with the SRQ, the IST flag combines the entire status information in a single bit. It can be queried by means of a parallel poll (cf. section "[Parallel Poll](#)", page 5.33") or using the command `"*IST?"`.

The parallel poll enable register (PPE) determines which bits of the STB contribute to the IST flag. The bits of the STB are ANDed with the corresponding bits of the PPE, with bit 6 being used as well in contrast to the SRE. The IST flag results from the ORing of all results. The PPE can be set using commands `"*PRE"` and read using command `"*PRE?"`.

## Event Status Register (ESR) and Event Status Enable Register (ESE)

The ESR is defined in IEEE 488.2. The event status register can be read out using command "\*ESR?". The ESE is the associated ENABLE part. It can be set using the command "\*ESE" and read using the command "\*ESE?".

Table 5-3 Meaning of the bits used in the event status register

Bit No.	Meaning
0	Operation Complete This bit is set on receipt of the command *OPC exactly when all previous commands have been executed.
1	not used
2	Query Error This bit is set if either the controller wants to read data from the instrument without having sent a query, or if it does not fetch requested data and sends new instructions to the instrument instead. The cause is often a query which is faulty and hence cannot be executed.
3	Device-dependent Error This bit is set if a device-dependent error occurs. An error message with a number between -300 and -399 or a positive error number, which denotes the error in greater detail, is entered into the error queue.
4	Execution Error This bit is set if a received command is syntactically correct but cannot be performed for other reasons. An error message with a number between -200 and -300, which denotes the error in greater detail, is entered into the error queue.
5	Command Error This bit is set if a command which is undefined or syntactically incorrect is received. An error message with a number between -100 and -200, which denotes the error in greater detail, is entered into the error queue.
6	User Request This bit is set on pressing the <b>LOCAL</b> key, i.e., when the instrument is switched over to manual operation.
7	<b>Power On</b> (supply voltage on) This bit is set on switching on the instrument.



## Application of the Status Reporting System

In order to effectively use the status reporting system, the information contained there must be transmitted to the controller and further processed. There are several methods, which are outlined in the following.

### Service Request

Under certain circumstances, the instrument can send a service request (SRQ) to the controller. Usually this service request initiates an interrupt at the controller, to which the control program can react appropriately. As evident from section "[Overview of the Status Register](#)", page 5.30, an SRQ is always initiated if one or several of bits 2, 4 or 5 of the status byte are set and enabled in the SRE. Each of these bits combines the information of the error queue or the output buffer. In order to use the possibilities of the service request effectively, all bits should be set to "1" in the enable registers SRE and ESE.

Example:

Use command `*OPC` to generate an SRQ

- `CALL IBWRT(generator%, "*ESE 1")` set bit 0 of ESE (Operation Complete)
- `CALL IBWRT(generator%, "*SRE 32")` set bit 5 of SRE (ESB)

After its settings have been completed, the instrument generates an SRQ.

The SRQ is the only possibility for the instrument to become active on its own. Each controller program should set the instrument such that a service request is initiated in the case of malfunction. The program should react appropriately to the service request.

### Serial Poll

In a serial poll, just as upon the command `*STB`, the status byte of an instrument is queried. However, the query is made via interface messages and is thus clearly faster. The serial-poll method has already been defined in IEEE 488.1 and used to be the only standard possibility for different instruments to poll the status byte. The method also works for instruments which do not adhere to SCPI or IEEE 488.2. The VISUAL BASIC command for executing a serial poll is `IBRSP()`. The serial poll is mainly used to obtain a fast overview of the state of several instruments connected to the IEC/IEEE bus or via the Ethernet.

### Parallel Poll

In a parallel poll, the controller uses a single command to request up to eight instruments to transmit one bit of information each on the data lines, i.e., to set the data line allocated to each instrument to a logical "0" or "1". In addition to the SRE register, which determines the conditions under which an SRQ is generated, there is a parallel poll enable register (PPE). This register is ANDed with the STB bit by bit, considering bit 6 as well. The results are ORed, the result is possibly inverted and then sent as a response to the parallel poll of the controller. The result can also be queried without parallel poll by means of the command `*IST?`.

The instrument first has to be set for the parallel poll using the VISUAL BASIC command "IBPPC()". This command allocates a data line to the instrument and determines whether the response is to be inverted. The parallel poll itself is executed using "IBRPP()".

The parallel poll method is mainly used to find out quickly which one of the instruments connected to the IEC/IEEE bus has sent a service request. To this effect, SRE and PPE must be set to the same value.

## **Query by Means of Commands**

Each part of any status register can be read by means of queries. The individual commands are listed in the description of the STATUS Subsystem. The returned value is always a number that represents the bit pattern of the register queried. This number is evaluated by the controller program.

Queries are usually used after an SRQ in order to obtain more detailed information on the cause of the SRQ.

## **Error Queue Query**

Each error state in the instrument leads to an entry in the error queue. The entries of the error queue are detailed plain-text error messages that can be looked at in the ERROR menu via manual operation or queried via the IEC/IEEE bus or via the Ethernet using command "SYSTEM:ERROR?". Each call of "SYSTEM:ERROR?" provides one entry from the error queue. If no error messages are stored there any more, the instrument responds with 0, "No error".

The error queue should be queried after every SRQ in the controller program as the entries describe the cause of an error more precisely than the status registers. Especially in the test phase of a controller program the error queue should be queried regularly since faulty commands from the controller to the instrument are recorded there as well.

## Reset Values of the Status Reporting Systems

Commands \*RST, \*DCL and SYSTem:PRESet and switching on the supply voltage also affect the status reporting system. None of the commands, except for \*RST and SYSTem:PRESet influences the functional instrument settings. In particular, DCL does not change the instrument settings.

Table 5-4 Resetting the Status Reporting System

Event	Switching on supply voltage		DCL,SDC (Device Clear, Selected Device Clear)	*RST or SYSTem:PRESet	STATus:PRESet	*CLS
	Power-On-Status-Clear	0				
Clear STB,ESR	–	yes	–	–	–	yes
Clear SRE,ESE	–	yes	–	–	–	–
Clear PPE	–	yes	–	–	–	–
Clear error-queue	yes	yes	–	–	–	yes
Clear output buffer	yes	yes	yes	1)	1)	1)
Clear command processing and input buffer	yes	yes	yes	–	–	–

1) Every command being the first in a command line, i.e. immediately following a <PROGRAM MESSAGE TERMINATOR> clears the output buffer



## Contents - Chapter 6 "Remote Control Commands"

<b>Remote-Control Commands - Description of Commands .....</b>	<b>6.1</b>
Notation .....	6.1
Table of Commands .....	6.1
Command Description .....	6.3
BERT and BLER Subsystems .....	6.8
OUTPut Subsystem .....	6.38
Power Sensor Measurements - SENSE, READ and INITiate Subsystems .....	6.42
SOURce Subsystem .....	6.49
SOURce:AM Subsystem .....	6.49
SOURce:BB Subsystem - Remote-Control Commands .....	6.65
Introduction - Baseband Remote-Control Commands .....	6.65
Table of Commands - SOURce:BB .....	6.65
SOURce:BB:ARB Subsystem - Remote Control Commands .....	6.68
Introduction - ARB Remote-Control Commands .....	6.68
Table of Commands - ARB .....	6.68
R&S Signal Generator Waveform and List Format .....	6.100
Creating a Waveform Manually .....	6.105
SOURce:BB:DM Subsystem - Remote-Control Commands .....	6.110
Introduction - DM General Remote-Control Commands .....	6.110
Table of Commands - DM General Remote-Control Commands .....	6.110
Introduction - DM Lists - Remote-Control Commands .....	6.131
Table of Commands - DM Lists .....	6.131
SOURce-BB-IMPairment Subsystem .....	6.144
SOURce:CORRection Subsystem .....	6.147
SOURce:FM Subsystem .....	6.156
SOURce:FREQuency Subsystem .....	6.158
SOURce:LFOutput Subsystem .....	6.164
SOURce:LIST Subsystem .....	6.171
SOURce:MODulation Subsystem .....	6.182
SOURce:PHASe Subsystem .....	6.183
SOURce:PM Subsystem .....	6.184
SOURce:POWer Subsystem .....	6.187
SOURce:PULM Subsystem .....	6.194

SOURce:ROSCillator Subsystem ..... 6.196

SOURce:SWEEP Subsystem ..... 6.198

SOURce-INPut Subsystem ..... 6.205

SOURce-IQ Subsystem - I/Q Modulation..... 6.208

SOURce-IQ-OUTPut Subsystem - Differential Outputs ..... 6.211

SOURce-IQ-OUTPut Subsystem - Digital I/Q Outputs ..... 6.214

STATus Subsystem..... 6.219

SYSTem Subsystem ..... 6.223

TEST Subsystem..... 6.229

TRIGger Subsystem..... 6.231

UNIT Subsystem ..... 6.236

## 6 Remote-Control Commands - Description of Commands

In the following, all remote-control commands will be presented in detail with their parameters and the ranges of numerical values.

An introduction to remote control and the status registers is given in chapter 5.

### Notation

All commands implemented in the instrument are first listed in tables and then described in detail, arranged alphabetically according to the command subsystems. The notation is adapted to the SCPI standard. The SCPI conformity information is included in the individual description of the commands.

#### Table of Commands

Command:	In the command column, the table provides an overview of the commands.
Parameter:	The parameter column indicates the requested parameters together with their specified range.
Unit:	The unit column indicates the basic unit of the physical parameters.
Remark:	In the remark column an indication is made on: <ul style="list-style-type: none"> <li>– whether the command does not have a query form,</li> <li>– whether the command has only one query form</li> </ul>

**Individual description** The individual description contains the complete notation of the command. An example for each command, the \*RST value and the SCPI information are included as well. The options that are required to execute the command are listed. In case of dependencies between commands they are also indicated.

**Upper/lower case notation** Upper/lower case letters are used to mark the long or short form of the key words of a command in the description (see Chapter 5). The instrument itself does not distinguish between upper and lower case letters.

**Special characters |** A selection of key words with an identical effect exists for several commands. These keywords are indicated in the same line; they are separated by a vertical stroke. Only one of these keywords needs to be included in the header of the command. The effect of the command is independent of which of the keywords is used.

**Example:** `SOURce:FREQuency:CW|:FIXed`

The two following commands with identical meaning can be created. They set the frequency of the fixed frequency signal to 1 kHz

`SOURce:FREQuency:CW 1E3 = SENSE:FREQuency:FIXed 1E3`

A vertical stroke in parameter indications marks alternative possibilities in the sense of "or". The effect of the command is different, depending on which parameter is used.

Example: Selection of the parameters for the command

```
SOURce:COUPling AC | DC
```

If parameter AC is selected, only the AC content is fed through, in the case of DC, the DC as well as the AC content.

[ ] Key words in square brackets can be omitted when composing the header (cf. Chapter 5, Optional Keywords). The full command length must be accepted by the instrument for reasons of compatibility with the SCPI standards.

Parameters in square brackets can be incorporated optionally in the command or omitted as well.

{ } Parameters in braces can be incorporated optionally in the command, either not at all, once or several times..

**Description of parameters** Due to the standardization, the parameter section of SCPI commands consists always of the same syntactical elements. SCPI has therefore specified a series of definitions, which are used in the tables of commands. In the tables, these established definitions are indicated in angled brackets (<...>) and will be briefly explained in the following (see also Chapter 5, Section "Parameters").

<Boolean> This keyword refers to parameters which can adopt two states, "on" and "off". The "off" state may either be indicated by the keyword **OFF** or by the numeric value 0, the "on" state is indicated by **ON** or any numeric value other than zero. Parameter queries are always returned the numeric value 0 or 1.

<numeric\_value>

<num>

These keywords mark parameters which may be entered as numeric values or be set using specific keywords (character data).

The following keywords given below are permitted:

**MINimum** This keyword sets the parameter to the smallest possible value.

**MAXimum** This keyword sets the parameter to the largest possible value.

**DEFault** This keyword is used to reset the parameter to its default value.

**UP** This keyword increments the parameter value.

**DOWN** This keyword decrements the parameter value.

The numeric values associated to **MAXimum**/**MINimum**/**DEFault** can be queried by adding the corresponding keywords to the command. They must be entered following the quotation mark.

Example: `SOURce:FREQuency? MAXimum`

eturns the maximum possible numeric value of the center frequency as result.

<arbitrary block program data>

This keyword is provided for commands the parameters of which consist of a binary data block.



## Command Description

### Common Commands

The common commands are taken from the standard IEEE 488.2 (IEC 625.2). Identical commands have an identical effect in different instruments. The headers of these commands consist of an asterisk "\*" followed by three letters. Many common commands affect the status reporting system, which is described in detail in Chapter 5.

Command	Parameters	Default unit	Remark
*CLS			Clear status; no query
*ESE	0...255		Event status enable
*ESR?	0...255		Standard event status query; query only
*IDN?			Identification query; query only
*IST?	0...255		Individual status query; query only
*OPC			Operation complete
*OPT?			Option identification query; query only
*PRE	0...255		Parallel poll register enable
*PSC	0   1		Power on status clear
*RCL	1...10		Recall
*RST			Reset; no query
*SAV	1...10		Save
*SRE	0...255		Service request enable
*STB?			Status byte query; query only
*TRG			Trigger; no query
*TST?			Self test query; query only
*WAI			Wait to continue; no query

#### \*CLS

**CLEAR STATUS** sets the status byte (STB), the standard event register (ESR), and the EVENT part of the QUESTIONable and OPERATION register to zero. The command does not change the enable and transition parts of the registers. It deletes the output buffer.

#### \*ESE 0...255

**EVENT STATUS ENABLE** sets the event status enable register to the specified value. The \*ESE? query command returns the content of the event status enable register in decimal form.

#### \*ESR?

**STANDARD EVENT STATUS QUERY** returns the content of the event status register in decimal form (0...255) and then sets the register to zero.

**\*IDN?**

**IDENTIFICATION QUERY** queries the instrument identification. The instrument type, serial number and firmware version are returned.

**\*IST?**

**INDIVIDUAL STATUS QUERY** returns the content of the IST flag in decimal form (0 | 1). The IST flag is the status bit which is sent during a parallel poll.

**\*OPC**

**OPERATION COMPLETE** sets bit 0 in the event status register when all previous commands have been processed. This bit can be used to trigger a service request.

**\*OPC?**

**OPERATION COMPLETE QUERY** returns a 1 when all previous commands have been processed. It is important to ensure that the timeout set at the IEC/IEEE bus is long enough.

**\*OPT?**

**OPTION IDENTIFICATION QUERY** queries the options configured in the instrument and returns a list of the installed options. The options are separated by commas.

**\*PRE 0 ... 255**

**PARALLEL POLL REGISTER ENABLE** sets the parallel poll enable register to the specified value. The \*PRE? query command returns the content of the parallel poll enable register in decimal form.

**\*PSC 0 | 1**

**POWER ON STATUS CLEAR** determines whether the content of the ENABLE registers are retained or reset at power on.

**Parameters:**       **0**

The content of the status registers is retained at power on. If the status registers ESE and SRE are configured accordingly, this may cause a service request to be triggered at power on.

**1**

The content of the status registers is reset at power on.

The **query** \*PSC? retrieves the contents of the Power-on-Status-Clear flag. The answer is either 0 or 1.

**\*RCL <number>**

**RECALL** calls up the instrument status which was stored under the specified number using the \*SAV command, e.g. \*SAV 4. It also activates the instrument settings which are stored in a file and loaded using the `MMEMory:LOAD <number>, <file_name.extension>` command.

**\*RST**

**RESET** resets the instrument to a defined default state. (see section "Preset Commands", on page 6.6)

**\*SAV <number>**

**SAVE** stores the current device state under the specified number (see also \*RCL). The command is used to store the current instrument state in an intermediate memory. The instrument state can be recalled by using the command \*RCL with the associated number.

To transfer the stored instrument settings in a file, command `MMEMoRY:STORe <number>, <file_name.extension>` is used. Parameter file extension is \*.savrcl. Parameter <number> is the specific number defined with the \*SAV command, e.g. \*SAV 4.

**\*SRE 0 ... 255**

**SERVICE REQUEST ENABLE** sets the service request enable register to the specified value. Bit 6 (MSS enable bit) remains 0. This command determines the conditions under which a service request is triggered. The \*SRE? query command reads out the content of the service request enable register in decimal form. Bit 6 is always 0.

**\*STB?**

**READ STATUS BYTE QUERY** reads out the content of the status byte in decimal form.

**\*TRG**

**TRIGGER** triggers all actions which are waiting for a trigger event. Specific trigger events can be triggered by means of the "TRIGger" command system (sweep and lists) or the SOURce subsystems (baseband).

**\*TST?**

**SELF TEST QUERY** triggers all self tests of the instrument and outputs an error code in decimal form (see Service Manual supplied with the instrument).

**\*WAI**

**WAIT-to-CONTINUE** does not allow subsequent commands to be processed until all previous commands have been executed and all signals are in their transient condition.

## Preset Commands

The preset commands are not bundled in one subsystem. Therefore, they are listed separately in this section. In addition, a specific preset command is provided for each digital standard and for the fader. These specific commands are described in the associated subsystems.

Four presetting actions are available:

1. Activating the default state of all internal instrument functions (\*RST). Functions that concern the integration of the instrument into a measurement setup are not changed, e.g. IEC/IEEE bus address or reference oscillator source settings.
2. Activating the preset state of the parameters related to the selected signal path (SOURCE<[1]:2>:PRESet)
3. Activating the preset state of all parameters that are not related to the signal path (DEVIce:PRESet)
4. Activating the original state of delivery (factory reset, SYSTem:FPRreset). Only functions that are protected by a password remain unchanged as well as the passwords themselves.

Command	Parameters	Default unit	Remark
DEVIce:PRESet			No query
*RST			No query
SOURCE<[1]:2>:Preset			No query
SYSTem:FPRreset			No query

### DEVIce:PRESet

The command presets all parameters which are not related to the signal path. This includes presetting the LF generator and bit/block error measurement.

The command triggers an event and therefore has no query form and no \*RST value.

**Example:** "DEV: PRES"  
'presets all instruments settings that are not related to the signal path.

*RST value	Resolution	SCPI
-	-	Device-specific

### \*RST

**RESET** resets the instrument to a defined default state. The command has the same effect as pressing the **PRESET** key. The default setting is given in the description of the commands.

Fading (if available) and transient recorder are only preset by this command.

Functions that concern mainly the integration of the instrument into a measurement setup or are password related are not changed:

- Reference frequency settings
- Power on settings
- Network settings
- IEC/IEEE-bus address
- Password and settings protected by passwords
- Start/Stop Gui Update
- Display and keyboard settings

**SOURce<[1]:2>:PRESet**

The command presets all parameters which are related to the selected signal path.

Fading (if available) and transient recorder are only preset by command \*RST.

For two-path instruments, the suffix under SOURce distinguishes the paths:

SOURce[1] = path A

SOURce2 = path B

The command triggers an event and therefore has no query form and no \*RST value.

**Example:**           " SOUR : PRES "  
                          'presets all settings that are related to signal path.

*RST value	Resolution	SCPI
-	-	Device-specific

**SYSTem:FPRreset**

The command triggers an instrument reset to the original state of delivery. This includes also the parameters, that are unchanged when executing a regular Preset with the \*RST command, e.g. IEC/IEEE bus address.

However, password settings and all settings protected by these password are not changed, e.g. disabled USB connections, LAN settings and reference oscillator setting.

The command triggers an event and therefore has no \*RST value and no query form.

**Example:**           SYST : FPR  
                          'all instrument settings (also those that are not currently active) are reset to the factory values.

*RST value	Resolution	Options	SCPI
-	-		Device-specific

## BERT and BLER Subsystems

These subsystems contain the commands for the bit and block error rate measurement. Since the commands for these two subsystems are essentially identical, they are summarized in the following section.

Command	Parameters	Default unit	Remarks
BERT:RESult			Query only
BERT:SEquence	AUTO   SINGLE		
BERT:SETup:CLOCK[:POLarity]	RISing   FALLing		
BERT:SETup:DATA[:POLarity]	NORMal   INVerted		
BERT:SETup:DENable	OFF   LOW   HIGH		
BERT:SETup:IGNore	OFF   ONE   ZERO		
BERT:SETup:MCOunt	0.0 ... 4294967295.0		
BERT:SETup:MERRor	0.0 ... 4294967295.0		
BERT:SETup:REStart:STATe	ON   OFF		
BERT:SETup:TYPE	PRBS9   PRBS11   PRBS15   PRBS16   PRBS20   PRBS21   PRBS23		
BERT:START			No query
BERT:STATe	ON   OFF		
BERT:STOP			No query
BERT:UNIT	ENGineering   SCientific   PCT   PPM		
BLER:RESult			Query only
BLER:SEquence	AUTO   SINGLE		
BLER:SETup:CLOCK[:POLarity]	RISing   FALLing		
BLER:SETup:CORDer	LSB   MSB		
BLER:SETup:DATA[:POLarity]	NORMal   INVerted		
BLER:SETup:DENable	LOW   HIGH		
BLER:SETup:MCOunt	0.0 ... 4294967295.0		
BLER:SETup:MERRor	0.0 ... 4294967295.0		
BLER:SETup:TYPE			Query only
BLER:START			No query
BLER:STATe	ON   OFF		
BLER:STOP			No query
BLER:UNIT	ENGineering   SCientific   PCT   PPM		
[SOURce:]INPut:BERT:IMPedance	G50   G1K		
[SOURce:]INPut:BERT:THReshold	0.01 .. 2.0	Volt	
TRIGger:BERT[:IMMEDIATE]			No query
TRIGger:BLER[:IMMEDIATE]			No query

**BERT:RESult?**

**BLER:RESult?**

Queries the result of the last BER measurement/BLER measurement. The response consists of seven results separated by commas. In the first measurement following the start, intermediate results for the number of data bits/data blocks, error bits/errors and error rate are also queried. In the following measurements (only for BERT:SEQ AUTO/for BLER:SEQ AUTO) only the final results of each single measurement are queried.

**Note:**

*At the end of a measurement, the restart of a new one is delayed until the first measurement result has been queried with BERT:RES?. The resulting brief measurement interruption is irrelevant because the subsequent measurement will be synchronized within 24 data bits.*

This command is a query and has therefore no \*RST value.

**Parameters:**

**Value 1**Number of checked data bits/data blocks.

**Value 2**Number of error bits/errors

**Value 3**Error rate. If no termination criterion has been reached since the beginning of the measurement, the current quotient of "Number of error bits/errors" and "Number of data bits/data blocks" is entered. As soon as at least one final result has been reached in continuous measurement, the most recent final result is entered.

**Value 4**Status of measurement.

1 = Measurement has been terminated, i.e. the number of data bits/data blocks or error bits/errors preset by the commands

" :BERT|BLER:SETup:MCOUNT " and " :BERT|BLER:SETup:MERROR " has been reached, or the measurement has been stopped by the command " :BERT|BLER:STOP ".

0 = Measurement has not been terminated.

**Value 5**

Status of clock line.

1 = Clock line active.

0 = Clock line not active.

**Value 6**

Status of data line.

1 = Data line active (only clocked data is detected; if the clock signal is missing, a data change is also not detected).

0 = Data line is not active.

**Value 7**

Synchronization status.

1 = The measurement is synchronized, i.e. the clock and data lines are active and the "Number of error bits/errors" to "Number of data bits/data blocks" ratio is better than 0.1, so that the measurement ratio can be assumed to be realistic.

0 = The measurement is not synchronized.

**Example:**

"BERT:RES?"

'queries the result of the bit error rate measurement.

Response: "1000,5,5E-4,1,1,1,1"

'the measurement has been terminated, and synchronization has been performed. Out of 1000 data bits, 5 error bits were measured, yielding an error rate of 0.005.

*RST value	Resolution	SCPI
-		Device-specific

**BERT:SEquence** AUTO | SINGle

**BLER:SEquence** AUTO | SINGle

Selects the type of measurement: single or continuous measurement.

**Parameters:**

**AUTO**

Continuous measurement. If one or both termination criteria are met, the measurement in progress is terminated. At the end of a measurement, the restart of a new one is delayed until the first measurement result has been queried with `BERT:RES?`. The resulting brief measurement interruption is irrelevant because the subsequent measurement will be synchronized within 24 data bits.

**SINGle**

Single measurement. A single measurement must be started with `:TRIG:BERT`. A single measurement is terminated once the set number of data bits/blocks or number of errors is reached.

**Example:**

```
"BERT:SEQ SING"
'selects single measurement.

"TRIG:BERT"
'starts the single measurement.
```

*RST value	Resolution	Dependencies	SCPI
AUTO	-	These commands are automatically set to AUTO by BERT:START or BLER:START	Device-specific

**BERT:SETup:CLOCK[:POLarity]** RISing | FALLing

**BLER:SETup:CLOCK[:POLarity]** RISing | FALLing

Sets the polarity of the active slope of the feedback clock.

**Parameters:**

**RISing**

The positive slope of the clock signal is active.

**FALLing**

The negative slope of the clock signal is active.

**Example:**

```
"BERT:SET:CLOC FALL"
'selects the falling slope of the clock signal as the active slope.
```

*RST value	Resolution	SCPI
RISing		Device-specific

**BLER:SETup:CORDer** LSB | MSB

Sets the byte order of the checksum (CRC).

**Parameters:**

**LSB**

The checksum starts with the least significant byte.

**MSB**

The checksum starts with the most significant byte.

**Example:**

```
"BLER:SET:CORD MSB"
'the checksum starts with the most significant byte.
```

*RST value	Resolution	SCPI
LSB		Device-specific



**BERT:SETup:DATA[:POLarity]** NORMal | INVerted

**BLER:SETup:DATA[:POLarity]** NORMal | INVerted

Sets the polarity of the feedback data bits.

**Parameters:**      **NORMal**

High level stands for a logic 1, low level for a logic 0.

**INVerted**

Low level stands for a logic 1, high level for a logic 0.

**Example:**      "BERT:SET:DATA INV"

'sets inversion of data signal.

*RST value	Resolution	SCPI
NORMal		Device-specific

**BERT:SETup:DENable** OFF | HIGH | LOW

**BLER:SETup:DENable** OFF | HIGH | LOW

Activates/deactivates the use of the **Data Enable** signal and the polarity of the signal if it is used. The **Data Enable** signal marks the data that is actually to be evaluated for the BER measurement. Any data in addition to the PRBS sequence is masked and thus not evaluated (e.g. sync, preambles, other channels, etc that are present in the data bits supplied by the DUT).

**Parameters:**      **OFF**

Any signal at the **Data Enable** input is ignored; all data at the BERT data input is used for the measurement.

**HIGH**

The **Data Enable** signal is used. The only data measured is the data at the BERT data input during a high level of the **Data Enable** signal. The measurement is interrupted during a low level of the **Data Enable** signal.

**LOW**

The **Data Enable** signal is used. The only data measured is the data at the BERT data input during a low level of the **Data Enable** signal. The measurement is interrupted during a high level of the **Data Enable** signal.

**Example:**      "BERT:SET:DEN HIGH"

'the measurement is interrupted during the low level of the **Data Enable** input.

*RST value	Resolution	SCPI
OFF		Device-specific

**BERT:SETup:IGNore** ONE | OFF | ZERO

Activates/deactivates ignoring of pure "0" or "1" bit sequences at least 32 bits long. Activating excludes faulty frames from the measurement. In the case of some mobile radio standards, pure "0" or "1" bit sequences are generated when errors (e.g. an incorrect checksum) are detected within a frame. These sequences, instead of the frame data, are provided for the BER measurement and signal that the frame in question should not be used for the measurement.

**Parameters:**      **OFF**

Pattern Ignore is not active.

**ONE**

Bit sequences consisting of 32 or more consecutive "1" data are not used (i.e. ignored) for the BER measurement.

**ZERO**

Bit sequences consisting of 32 or more consecutive "0" data are not used (i.e. ignored) for the BER measurement.

**Example:** "BERT:SET:IGN ONE"  
 'specifies that bit sequences of "1" data at least 32 bits long are not used for the measurement.

*RST value	Resolution	SCPI
OFF		Device-specific

**BERT:SETup:MCOunt** 0.0 ... 2<sup>32</sup>-1

**BLER:SETup:MCOunt** 0.0 ... 2<sup>32</sup>-1

Enters the number of transmitted data bits/data blocks to be checked before the measurement is terminated. With a BER measurement, data that was suppressed by BERT:SETup:DEnable is not counted. This termination criterion always terminates the measurement after the specified number of data bits/data blocks. Starting from this point, the fourth value is output with 1 (= terminate measurement) if the result is queried with :BERT|BLER:RES?. If the continuous measurement mode (BERT|BLER:SEQ AUTO) has been selected, the measurement is restarted once the results have been queried.

**Example:** "BERT:SET:MCO 1E6"  
 'sets a measurement over 1000000 data bits.  
 "BLER:SET:MCO 1E3"  
 'sets a measurement over 1000 data blocks.

*RST value	Resolution	SCPI
BERT: 10 000 000 BLER: 100 000		Device-specific

**BERT:SETup:MERRor** 0.0 ... 2<sup>32</sup>-1

**BLER:SETup:MERRor** 0.0 ... 2<sup>32</sup>-1

Enters the number of errors to occur before the measurement is terminated. This termination criterion always terminates the measurement after the specified number of errors. Starting from this point, the fourth value is output with 1 (= terminate measurement) if the measurement result is queried with :BERT|BLER:RES?.

**Example:** "BERT:SET:MERR 1E4"  
 'sets a measurement over 1000 errors.

*RST value	Resolution	SCPI
100		Device-specific

**BERT:SETup:REStart:STATe** ON | OFF

Activates/deactivates an external restart of the BER measurement.

**Parameters:**      **OFF**

The reset signal for the BER measurement is generated internally. This setting is suitable for PRBS sequences that run continuously and thus ensure uninterrupted repetition.

**ON**

The reset signal for the BER measurement is fed via the **Restart** input of the BERT interface.

If the PRBS sequence cannot be continued uninterruptedly, the BER measurement must be stopped at the end of the data sequence and subsequently restarted at the beginning of the new data sequence. The measurement is stopped and started via a 0-1-0 slope of the **Restart** signal. A transition from logic 0 to 1 causes a partial result to be generated and the measurement to be stopped. A transition from 1 to 0 starts the measurement for the next subinterval. This measurement is synchronized anew. If the R&S Vector Signal Generator is used as a data source, a signal in which a single 1 was coded at the end of the data sequence can be used as a restart signal at the R&S Vector Signal Generator marker output. This causes the BER measurement to stop briefly at the end of the data sequence and start again. Partial results (number of data and error bits) are added up until the predefined total number of data or error bits is reached or exceeded. The measurement is reset by **Pattern Ignore** or **Data Enable**, regardless of its status.

**Example:**            "BERT:SET:REST:STAT ON"  
                              'the external signal restarts the measurement.

*RST value	Resolution	SCPI
OFF		Device-specific

**BERT:SETup:TYPE** PRBS9 | PRBS11 | PRBS15 | PRBS16 | PRBS20 | PRBS21 | PRBS23

Selects the PRBS sequence. The data generated by the PRBS generator is used as a reference for the measurement.

**Example:**            "BERT:SET:TYPE PRBS15"  
                              'sets a pseudo random binary sequence consisting of 32767 bits.

*RST value	Resolution	SCPI
PRBS9		Device-specific

**BLER:SETup:TYPE?**

Queries the CRC polynomial used. CCITT CRC 16 :  $G(x) = x^{16} + x^{12} + x^5 + x^1$ . is the CRC polynomial supported.

This command is a query and therefore has no \*RST value.

**Example:**            "BLER:SET:TYPE?"  
                              'queries the type of measurement.  
  
Response: 'CRC16 '

*RST value	Resolution	SCPI
-		Device-specific

**BERT:START**

**BLER:START**

Starts a continuous measurement.

This command triggers an event and hence has no query and no \*RST value.

**Example:**       "BERT:STAR"  
                      'starts a continuous measurement.

*RST value	Resolution	Dependencies	SCPI
AUTO	-	These commands automatically set BERT:SEQuence or BLER:SEQuence to AUTO and BERT:STATe or BLER:STATe to ON	Device-specific

**BERT:STATe**

**BLER:STATe**

Switches the measurement on/off. Depending on the selected mode, either a continuous measurement (BERT|BLER:SEQ AUTO) or a single measurement (BERT|BLER:SEQ SING) is carried out. A single measurement must be triggered (:TRIG:BERT|BLER).

**Example:**       "BERT:SEQ SING"  
                      'selects a single measurement.  
  
                      "BERT:STAT ON"  
                      'switches the BER measurement on.  
  
                      ":TRIG:BERT"  
                      'starts a single measurement.

*RST value	Resolution	Dependencies	SCPI
OFF	-	These commands are automatically set to ON by BERT:START or BLER:START and to OFF by BERT:STOP or BLER:STOP	Device-specific

**BERT:STOP**

**BLER:STOP**

Stops an ongoing measurement.

This command triggers an event and hence has no query and no \*RST value.

**Example:**       "BERT:STOP"  
                      'stops the measurement. To start a new measurement, the BER measurement must be switched on again by BERT:STATe ON.

*RST value	Resolution	Dependencies	SCPI
-	-	These commands automatically set BERT:STATe or BLER:STATe to OFF	Device-specific

**BERT:UNIT** ENgineering | SCientific | PCT | PPM  
**BLER:UNIT** ENgineering | SCientific | PCT | PPM

Sets the unit for the error rate display on the screen. **BERT|BLER:RES?** always specifies the error rate as the quotient of "Number of errors" and "Number of data items", unaffected by this command.

- Parameters:**
- ENgineering**The error rate is output in exponential notation with the exponent  $-3$  or  $-6$ .
  - SCientific**The error rate is output in scientific notation, i.e. standardized to one place to the left of the decimal.
  - PCT**The error rate is output in percent.
  - PPM**  
The error rate is output in parts per million.

**Example:** "BERT:UNIT PPM"  
 'selects the unit "ppm" for the display of the error rate.

*RST value	Resolution	SCPI
ENG		Device-specific

**[SOURce:]INPut:BERT:IMPedance** G50 | G1K

The command sets the impedance of the BERT inputs **Clock**, **Data**, **Data Enable** and **Restart**.

**Example:** "INP:BERT:IMP G50"  
 'the impedance of the BERT inputs is set to 50 ohm to ground.

*RST value	Resolution	SCPI
G1K	-	Device-specific

**[SOURce:]INPut:BERT:THReshold** 0 ... 2.0 V

The command sets the high/low threshold of the BERT inputs **Clock**, **Data**, **Data Enable** and **Restart**. In the case of positive polarity, this threshold determines the point as of which a signal is high (active) or low (inactive).

**Example:** "INP:BERT:THR 1 V"  
 'a high/low threshold of 1 volt is set at the BERT inputs. The signal is high (active) for a signal voltage of 1 volt and higher.

*RST value	Resolution	SCPI
1.00 V	-	Device-specific

**TRIGger:BERT[:IMMEDIATE]**

**TRIGger:BLER[:IMMEDIATE]**

Triggers a single bit error rate or block error rate measurement if the single trigger mode (BERT|BLER:SEQ SING) is selected.

This command triggers an event and hence has no query and no \*RST value.

**Example:**       "BERT:SEQ SING"  
                  'selects the single trigger mode.  
                  "TRIG:BERT"  
                  'starts a single bit error rate measurement.

*RST value	Resolution	SCPI
-		Device-specific

## CALibration Subsystem

The CALibration system contains the commands for adjustment. Adjustment is triggered by the query commands. The response "0" indicates error-free adjustment, and the response "1" means that an error occurred during adjustment.

In the case of two-path instruments with a second RF path, adjustment can be set separately and independently for the two RF paths A and B. The suffix under SOURce distinguishes the outputs:

CALibrate[1] = RF path A

CALibrate2 = RF path B

Command	Parameters	Default unit	Remark
CALibration:ALL[:MEASure]?			Query only
CALibration:BBIN[:MEASure]?			Query only
CALibration:FMOFFset[:MEASure]?			Query only
CALibration<[1]]2>:FREQUency[:MEASure]?			Query only
CALibration<[1]]2>:IQModulator:FULL?			Query only
CALibration<[1]]2>:IQModulator:LOCal?			Query only
CALibration<[1]]2>:LEVel[:MEASure]?			Query only
CALibration<[1]]2>:LEVel:STATe	ON   OFF		

### CALibration:ALL[:MEASure]?

The command starts all internal adjustments for which no external measuring equipment is needed. With two-path instruments, adjustment is performed for both paths.

**Example:** "CAL:ALL:MEAS?"  
'starts the adjustment of all functions for the entire instrument.

Response: "0"  
'adjustment has been performed successfully.

*RST value	Resolution	SCPI
-	-	Compliant

### CALibration:BBIN[:MEASure]?

The command starts adjustment of the analog I/Q input. The I/Q input is adjusted with respect to DC offset and gain.

**Example:** "CAL:BBIN:MEAS?"  
'starts the adjustment of the analog I/Q input.

Response: "0"  
'adjustment has been performed successfully.

*RST value	Resolution	SCPI
-	-	Compliant

**CALibration<[1]|2>:FMOffset[:MEASure]?**

The command starts all adjustment for the FM/PhiM modulator.

**Example:** "CAL:FMOF?"  
 'starts the adjustments for the FM/Phim modulator.  
 Response: "0"  
 'the adjustments have been performed successfully.

*RST value	Resolution	SCPI
-	-	Device-specific

**CALibration<[1]|2>:FREQUENCY[:MEASure]?**

The command starts all adjustments which affect the frequency (in case of two-path instruments, this affects the selected path).

**Example:** "CAL:FREQ:MEAS?"  
 'starts the adjustments for maximum frequency accuracy.  
 Response: "0"  
 'the adjustments have been performed successfully.

*RST value	Resolution	SCPI
-	-	Device-specific

**CALibration<[1]|2>:IQModulator:FULL?**

The command starts adjustment of the I/Q modulator for the entire frequency range. The I/Q modulator is adjusted with respect to carrier leakage, I/Q imbalance and quadrature.

The command is a query command and therefore has no \*RST value.

**Example:** "CAL:IQM:FULL?"  
 'starts adjustments for the I/Q modulator across the entire frequency range.  
 Response: "0"  
 'adjustment has been performed successfully.

*RST value	Resolution	SCPI
-	-	Device-specific

**CALibration<[1]|2>:IQModulation:LOCAl?**

The command starts adjustment of the I/Q modulator for the currently set frequency, I/Q swap and baseband gain. The I/Q modulator is adjusted with respect to carrier leakage, I/Q imbalance and quadrature.

The command is a query command and therefore has no \*RST value.

**Example:** "CAL:IQM:LOC?"  
 'starts adjustment for the I/Q modulator for the currently set frequency.  
 Response: "0"  
 'adjustment has been performed successfully.

*RST value	Resolution	SCPI
-	-	Device-specific



**CALibration<[1]|2>:LEVel[:MEASure]?**

The command starts all adjustments which affect the level (in case of two-path instruments, this affects the selected path).

**Example:** "CAL:LEV:MEAS?"  
'starts adjustments for maximum level accuracy.

Response: "0"  
'adjustment has been performed successfully.

*RST value	Resolution	SCPI
-	-	Device-specific

**CALibration<[1]|2>:LEVel:STATe**

The command switches on or off internal level correction.

**Example:** "CAL:LEV:STAT"  
'switches on Level correction.

*RST value	Resolution	SCPI
ON	-	Device-specific

**CALibration<[1]|2>:LEVel:HACCuracy[:STATe] ON | OFF**

Enables/disables level adjustment with high accuracy.

**Example:** "CAL:LEV:HACC:STAT ON"  
'switches on Hight Accuracy Level Adjustment

*RST value	Resolution	SCPI
OFF	-	Device-specific

## CLOCK Subsystem

The CLOCK system contains the commands for configuration of the signals at the clock output and input connectors.

Command	Parameters	Default unit	Remark
CLOCK:INPut:FREQuency			Query only
CLOCK:INPut:SLOPe	POSitive   NEGative		
CLOCK:OUTPut:MODE	BIT   SYMBol		
CLOCK:OUTPut:SOURce			Query only

### CLOCK:INPut:FREQuency

The command sets the measured frequency of the external clock signal. An external clock reference must be supplied at the CLOCK input.

The command is a query command and therefore does not have an \*RST value.

**Example:** "CLOC:INP:FREQ?"  
'queries the measured frequency of the external clock reference.

*RST value	Resolution	SCPI
	-	Device-specific

### CLOCK:INPut:SLOPe POSitive | NEGative

The command sets the active slope of an externally applied clock signal at the CLOCK connector.

**Example:** "CLOC:INP:SLOP NEG"  
'the active slope of the external clock signal at the CLOCK connector is the falling slope.

*RST value	Resolution	SCPI
POSitive	-	Device-specific

### CLOCK:OUTPut:MODE?

The command sets the output of bit or symbol clock pulses at the CLOCK OUT connector at the rear panel.

**Example:** "CLOC:OUTP:MODE SYMB"  
'the internal symbol clock is output at the CLOCK OUT connector

*RST value	Resolution	SCPI
SYMBol	-	Device-specific

**CLOCK:OUTPut:SOURce?**

The command queries the path for which the clock signal at the CLOCK OUT connector is to be output.

The command is a query command and therefore does not have an \*RST value.

**Example:** "CLOC:OUTP:SOUR?"  
 'queries the path for which the clock signal at the CLOCK OUT connector is to be output.

Response: A  
 'the clock signal of path is output at the CLOCK OUT connector.

*RST value	Resolution	SCPI
-	-	Device-specific

## DIAGnostic Subsystem

The DIAGnostic system contains the commands used for instrument diagnosis and servicing. SCPI does not define any DIAGnostic commands; the commands listed here are all Device-specific. All DIAGnostic commands are query commands which are not influenced by \*RST.

In the case of two-path instruments, the numerical suffix under DIAGnostic distinguishes between Path A and Path B:

DIAGnostic[1] = Path A

DIAGnostic2 = Path B

Command	Parameters	Default unit	Remark
DIAGnostic<[1] 2>:BGINfo?	<module name>		Query only
DIAGnostic<[1] 2>:BGINfo:CATalog?			Query only
DIAGnostic:INFO:OTIME?			Query only
DIAGnostic:INFO:POCount?			Query only
DIAGnostic<[1] 2>:POINt:CATalog?			Query only
DIAGnostic<[1] 2>[:MEASure]:POINt?	<point name>		Query only

### DIAGnostic<[1]|2>:BGINfo? <module name>

The command checks the modules available in the instrument using the variant and revision state.

If the command is sent without parameters being specified, a complete list of all modules is returned (the various entries are separated by commas). The length of the list is variable and depends on the instrument equipment configuration.

If the command is sent with parameters, a list of the specified modules is returned (the various entries are separated by commas). A list of modules names can be called up using the `DIAG:BGIN:CATalog?` command.

Each entry for one module consists of four parts which are separated by space characters:

Module name Module stock number incl. variant Module revision Module serial number.

For two-path instruments, the path for which the query is performed is determined by the numerical suffix.

**Example:**

"DIAG:BGIN?"  
'queries the instrument configuration.

Response: MBRD,SSYN,IQOP3,IQOP3\_LCM,....  
'returns the data of all available modules.

"DIAG:BGIN? 'MBRD' "  
'queries the configuration of the motherboard.

Response: MBRD 1141.3501.02 1.5.3 100023  
'module motherboard with stock number 1141.3501.01 has revision 1.5.3 and serial number 100023.

*RST value	Resolution	SCPI
-	-	Device-specific

**DIAGnostic<[1]|2>:BGInfo:CATalog?**

The command queries the names of the assemblies available in the instrument.

A complete list of all assemblies is returned (the various entries are separated by commas). The length of the list is variable and depends on the instrument equipment configuration.

For two-path instruments, the path for which the query is performed is determined by the numerical suffix.

**Example:** "DIAG:BGIN:CAT?"  
'queries the names of the assemblies.

Response: MBRD,SSYN,IQOP3,IQOP3\_LCM, . . . .

*RST value	Resolution	SCPI
-	-	Device-specific

**DIAGnostic:INFO:OTIMe?**

The command queries the number of operation hours

**Example:** "DIAG:INFO:OTIM?"  
'queries the operation hours.

Response: "100023"  
'the instrument was operated for 100023 hours up to now.

*RST value	Resolution	SCPI
-	-	Device-specific

**DIAGnostic:INFO:POCount?**

The command queries the number of power-on events.

**Example:** "DIAG:INFO:POC?"  
'queries the number of power on events.

Response: "123"  
'the instrument was switched on for 123 times up to now.

*RST value	Resolution	SCPI
-	-	Device-specific

**DIAGnostic<[1]|2>:POINt:CATalog?**

The command queries the test points available in the instrument. A detailed description of the test points can be found in chapter 3, section "Trouble Shooting" of the Service Manual (on CD-ROM, supplied with the instrument).

**Example:** "DIAG:POIN:CAT?"  
'queries the test points available in the instrument.

Response: 'DIAG\_IQOP3\_LCM\_CAL\_I,DIAG\_IQOP3\_LCM\_I, . . .

*RST value	Resolution	SCPI
-	-	Device-specific

**DIAGnostic<[1]|2>[:MEASure]:POINt?**

The command triggers voltage measurement at the specified test point and returns the measured voltage. A detailed description of the test points can be found in chapter 3, section "Trouble Shooting" of the Service Manual (on CD-ROM, supplied with the instrument).

A list of the available test points for the respective path can be queried using the `DIAG<[1]|2>:POIN:CAT?` command.

**Example:**           `"DIAG:POIN? 'DIAG_IQOP3_LCM_CAL_I'"`  
                          'triggers measurement at the test point `DIAG_IQOP3_LCM_CAL_I`.

Response: 0.5  
          'the voltage at the test point is 0.5 volt.

RST value	Resolution	SCPI
-	-	Device-specific

## DISPlay Subsystem

The DISPlay system contains the commands to set the power-save mode of the instrument.

Command	Parameters	Default unit	Remark
DISPlay:PSAVe:HOLDoff	1...60		
DISPlay:PSAVe[:STATe]	ON   OFF		

### DISPlay:PSAVe:HOLDoff 1 ... 60

This command sets the wait time for the screen-save mode of the display. The available value range is 1 to 60 minutes, the resolution 1 minute. The entry is dimensionless.

**Example:**           DISP:PSAV:HOLD 10  
                          "sets the wait for the screen saver mode to 10 minutes.

*RST value	Resolution	Options	SCPI
1	-		Device-specific

### DISPlay:PSAVe[:STATe] ON | OFF

This command activates/deactivates the screen-save mode of the display. With the screen-save mode activated the display including backlight is completely switched off after the elapse of the wait time (see command DISPlay:PSAVe:HOLDoff) when no entries via front panel, external mouse or external keyboard are made.

This mode is recommended for preserving the display especially if the instrument is exclusively operated via remote control.

**Example:**           DISP:PSAV ON  
                          "activates screen saver mode.

*RST value	Resolution	Options	SCPI
OFF	-		Device-specific

## FORMat Subsystem

The FORMat subsystem contains the commands which determine the format of the data that the R&S Vector Signal Generator returns to the controller. This affects all query commands which return a list of numerical data or block data. Reference is made to this in the descriptions of the commands.

For two-path instruments, the data format is set simultaneously for both paths.

Command	Parameters	Default unit	Remark
FORMat:BORDER	NORMal   SWAPped		
FORMat[:DATA]	ASCii   PACKed		
FORMat:SREGister	ASCii   BINary   HEXadecimal   OCTal		

### FORMat:BORDER NORMal | SWAPped

The command determines the sequence of bytes within a binary block. This only affects blocks which use the IEEE754 format internally.

**Parameters:**     **NORMal**  
 The R&S Vector Signal Generator expects (with setting commands) and sends (with queries) the least significant byte of each IEEE754 floating-point number first, and the most significant byte last.

**SWAPped**  
 The R&S Vector Signal Generator expects (with setting commands) and sends (with queries) the most significant byte of each IEEE754 floating-point number first, and the least significant byte last.

**Example:**       "FORM:BORD SWAP"  
                   'the data is transferred with the most significant bit first.

*RST value	Resolution	SCPI
NORMal	-	Compliant

### FORMat[:DATA] ASCii | PACKed

The command determines the data format which the R&S Vector Signal Generator uses to return data. When data is transferred from the control computer to the instrument, the instrument detects the data format automatically. In this case, the value set here is irrelevant.

**Parameters:**     **ASCii**  
 Numerical data is transferred as plain text separated by commas.

**PACKed**  
 Numerical data is transferred as binary block data. The format within the binary data depends on the command. The various binary data formats are explained in the description of the parameter types.

**Example:**       "FORM ASC"  
                   'the data is transferred as ASCII data.

*RST value	Resolution	SCPI
ASCii	-	Compliant



**FORMat:SREGister** ASCii | BINary | HEXadecimal | OCTal

The command determines the numerical format which is returned when the status registers are queried.

**Parameters:**

**ASCii**

The register content is returned as a decimal number.

**BINary**

The register content is returned as a binary number. #B is placed in front of the number.

**HEXadecimal**

The register content is returned as a hexadecimal number. #H is placed in front of the number.

**OCTal**

The register content is returned as an octal number. #Q is placed in front of the number.

**Example:**

"FORM:SREG HEX"

'the register content is returned as a hexadecimal number.

*RST value	Resolution	SCPI
ASCii	-	Compliant

### KBOard Subsystem

The KBOard system contains the commands to set the external keyboard.

Command	Parameters	Default unit	Remark
KBOard:LANGuage	US   DE		
KBOard:LAYout	US   DE		

#### KBOard:LANGuage US | DE

This command selects the keyboard language. The assignment of some keys depends on the selected language.

**Example:**           KBO:LANG US  
                          "selects keyboard language American English.

*RST value	Resolution	Options	SCPI
US	-		Device-specific

#### KBOard:LAYout US | DE

This command selects the keyboard layout for the selected keyboard language. The assignment of some keys depends on the selected layout and language.

**Example:**           KBO:LAY US  
                          "activates American keyboard layout

*RST value	Resolution	Options	SCPI
US	-		Device-specific

## MMEMory Subsystem

The MMEMory subsystem (Mass Memory) contains the commands for managing files and directories as well as for loading and storing complete instrument settings in files.

The various drives can be selected using the "mass storage unit specifier" <msus>. The internal hard disk is selected with "D:\", and a memory stick which is inserted at the USB interface is selected with "E:\". The resources of a network can also be selected with <msus> in the syntax of the respective network, e.g. using the UNC format (Universal Naming Convention): '\\server\share'.

The default drive is determined using the command `MMEMory:MSIS <msus>`.

---

**Note:**

*The C: drive is a protected system drive. This drive should not be accessed. Reconstruction of the system partition will not be possible without loss of data.*

---

To enable files in different file systems to be used, the following file naming conventions should be observed:

The file name can be of any length and no distinction is made between uppercase and lowercase letters. The file and the optional file extension are separated by a dot. All letters and numbers are permitted (numbers are, however, not permitted at the beginning of the file name). Where possible, special characters should not be used. Use of the slashes "\" and "/" should be avoided since they are used in file paths. A number of names are reserved by the operating system, e.g. CLOCK\$, CON, AUX, COM1...COM4, LPT1...LPT3, NUL and PRN.

In the R&S Vector Signal Generator all files in which lists and settings are stored are given a characteristic extension. The extension is separated from the actual file name by a dot (see the following table containing a list of the file types).

The two characters "\*" and "?" function as "wildcards", i.e. they are used for selecting several files. The "?" character represents exactly one character, while the "\*" character represents all characters up to the end of the file name. "\*.\*" therefore stands for all the files in a directory.

When used in conjunction with the commands, the parameter <file\_name> is specified as a string parameter with quotation marks. It can contain either the complete path including the drive, only the path and file name, or only the file name. The file name must include the file extension. The same applies for the parameters <directory\_name> and <path>. Depending on how much information is provided, either the values specified in the parameter or the values specified with the commands `MMEM:MSIS` (default drive) and `MMEM:CDIR` (default directory) are used for the path and drive setting in the commands.

Before the instrument settings can be stored in a file, they have to be stored in an intermediate memory using common command `*SAV <number>`. The specified number is subsequently used in the `MMEM.STOR:STATe<number>`, <file> command.

Also, subsequently to loading a file with instrument settings with command `MMEM:LOAD:STAT <number>`, <file>, these settings have to be activated with the common command `*RCL <number>`.

In the example below, the current instrument setting is always stored in the file 'test1.savrcl' in the directory 'user' on the internal hard disk.

\*SAV 4

MMEM:STOR:STAT 4, "d:\user\test1.savrc1"

If the complete path including the drive letter is specified, the file is stored in the specified path.

MMEM:MSIS 'D: '

\*SAV 4

MMEM:STOR:STAT 4, "\user\test1.savrc1"

If the parameter only contains the path and file name, the default drive set with the MMEM:MSIS command is effective.

MMEM:MSIS 'd:\ '

MMEM:CDIR 'user'

\*SAV 4

MMEM:STOR:STAT 4, "test1.savrc1"

If the parameter only contains the file name, the file is stored on the default drive MMEM:MSIS and in the default directory which was selected with the MMEM:CDIR command.

Table 6-1 List of file extensions assigned automatically in R&S Vector Signal Generator

List type	Contents	File suffix
<b>Instrument State</b>		
Instrument State	Instrument settings	*.savrc1
<b>User Correction</b>		
User Correction	User-defined level correction values	*.uco
<b>List Mode</b>		
List	User-defined frequency/level value pairs	*.lsw
<b>Frequency Response Correction</b>		
Frequency Response Correction	User-defined frequency response correction file	*.frc
<b>Arbitrary Waveform Generator</b>		
Waveform Multi segment waveform	ARB ARB multi segment waveforms	waveforms *.wv
Multi carrier waveform	ARB multi carrier settings	*.arb_multcarr
Configuration data	Configuration file for creation of multisegment ARB waveforms	*.inf_mswv
Waveform File	Waveform File	*.wav
<b>DM</b>		
Data List	Digital modulation data	*.dm_iqd *.tdm
Control List	Data to control digital modulation	*.dm_iqc
Settings	Digital modulation settings	*.dm
User Standard	Digital modulation user standard	*.dm_stu
User Mapping	Digital modulation user mapping	*.vam
User Filter	Digital modulation user filter	*.vaf
<b>Fading</b>		
Fading	Fading data	*.fad
<b>GSM/EDGE</b>		
Settings	GSM/EDGE settings	*.gsm
Slot	User-defined slot data	*.gsm_slu
Frame	User-defined frame data	*.gsm_fu

List type	Contents	File suffix
Higher symbol rate slot	Higher symbol rate slot	*.gsm_hslu
Higher symbol rate frame	Higher symbol rate frame	*.gsm_hfu
<b>3GPP FDD</b>		
3GPP Settings	Complete setting of the 2GPP (FDD) menu	*.3g
Channel Coding DPCH	Channel coding enhanced DPCH channels (downlink)	*.3g_ccod_dl_s
Channel Coding DPDCH	Channel coding enhanced DPDCH channels (uplink)	*.3g_ccod_ul
<b>CDMA2000</b>		
CDMA2000 Settings	Complete setting of the CDMA2000 menu	*.cdma2k
<b>TD-SCDMA2000</b>		
TD-SCDMA2000 Settings	Complete setting of the TD-SCDMA2000 menu	*.tdscdma
TD-SCDMA Test Model	Test Model for TD-SCDMA2000	*.tdtmd
<b>1xEV-DO</b>		
1xEV-DO Settings	Complete setting of the 1xEV-DO menu	*.evdo
<b>IEEE 802.11 WLAN</b>		
WLAN Settings	Complete setting of the IEEE 802.11 WLAN menu	*.wlan
<b>IEEE 802.11 n WLAN</b>		
WLAN n Settings	Complete setting of the IEEE 802.11n WLAN menu	*.wlann
Beamforming data	Beamforming data	*.bmf
<b>IEEE 802.16 WiMAX</b>		
WiMAX Settings	Complete setting of the IEEE 802.16 WiMAX menu	*.wimax
<b>EUTRA/LTE</b>		
EUTRA/LTE Settings	Complete setting of the EUTRA/LTE menu	*.eutra
IQW Data List	User-defined IQ-File	*.iqw
<b>GPS</b>		
GPS/A-GPS Settings	Complete setting of the GPS/A-GPS menu	*.gps
GPS Almanac Settings	GPS Almanac Settings	*.txt *.alm *.al3
GPS Waypoints File	GPS Waypoints File	*.txt
GPS Generated Almanac File	GPS Generated Almanac File	*rs_al *.rs_yuma
GPS Ionospheric File	GPS Ionospheric File	*.rs_ion
GPS Navigation Data	GPS Navigation Data	*.rs_nav
GPS UTC File	GPS UTC File	*.rs_utc *.rs_acq
<b>FM-Stereo</b>		
FM-Stereo Settings	Complete setting of the FM-Stereo menu	*.fmstereo
FM-Stereo Group Type Settings	FM-Stereo Group Type Settings	*.fm_gt
<b>XM-Radio</b>		
XM-Radio Settings	Complete setting of the XM-Radio menu	*.xmradio
XM-Radio TWTA Data	XM-Radio TWTA Data	*.twta
<b>DVB</b>		
DVB Settings	Complete setting of the DVB menu	*.dvh
DVB Transport Stream	DVB Transport Stream	*.gts *.ts *.trp
<b>DAB/T-DMB</b>		

List type	Contents	File suffix
DAB/T-DMB Settings	Complete setting of the DAB/T-DMB menu	*.dab
DAB ETI Files	DAB ETI Files	*.eti *.xeti

## MMEMory - Command Table

Command	Parameters	Default unit	Remark
MMEMory:CATalog?	<path>		Query only
MMEMory:CATalog:LENGth?			Query only
MMEMory:CDIRectory	<directory_name>		No query
MMEMory:COPIY	<file_name>,<file_name>		No query
MMEMory:DATA	<file_name>[,<block>]		
MMEMory:DCATalog?			Query only
MMEMory:DCATalog:LENGth?			Query only
MMEMory:LOAD:STATe	<number>,<file_name>		No query
MMEMory:DELeTe	<file_name>		No query
MMEMory:MDIRectory	<directory_name>		No query
MMEMory:MOVE	<file_name>,<file_name>		No query
MMEMory:MSIS	<msus>		
MMEMory:RDIRectory	<directory_name>		
MMEMory:STORe:STATe	<number>,<file_name>		

### MMEMory:CATalog? <path>

This command reads out the subdirectories and files in the specified directory. If no directory is specified, the default directory selected with the `MMEM:CDIR` command is read out on the default drive selected with the `MMEM:MSIS` command.

The response has the following format:

```
<used_bytes_in_this_directory>,<free_bytes_on_this_disk>,  
"<file_name>,<file_type>,<filesize_in_bytes>",&br/>"<file_name>,<file_type>,<filesize_in_bytes>"," ...
```

The command is a query command and therefore has no \*RST value.

- Parameters:**
- <file\_name>**  
File or directory name.
  - <file\_type>**  
File type. There are the following file types: DIR (directory), ASCii (ASCII file), BINary (Binary file), and STATe (file with instrument settings).
  - <filesize\_in\_bytes>**  
File size. The size "0" is returned for a directory.

**Example:** "MMEM:CAT? '\\Server\DATA\\*.LOG'  
 Reads back all files in \\Server\DATA with the extension ".LOG".

"MMEM:CAT? 'd:\user'"  
 'reads out all files at the highest directory level of the memory stick.

Response:  
 ""127145265,175325184,"test,DIR,0","temp,DIR,0","readme.txt,ASC,1324","state.savrcl,STAT,5327","waveform.wv,BIN,2342"  
 'the directory D:\User contains the subdirectories 'test' and 'temp' as well as the files 'readme.txt', 'state.savrcl' and 'waveform.wv' which have different file types.

*RST value	Resolution	SCPI
-	-	Compliant

### MMEMory:CATalog:LENGth? <path>

This command reads out the number of files in the specified directory. If no directory is specified, the default directory selected with the MMEM:CDIR command is read out on the default drive selected with the MMEM:MSIS command.

The command is a query command and therefore has no \*RST value.

**Example:** "MMEM:CAT:LENG? 'e:\'"  
 'reads out the number of files at the highest directory level of the memory stick.

Response: ""1"  
 'there is 1 file at the highest directory level of the memory stick.

*RST value	Resolution	SCPI
-	-	Device-specific

### MMEMory:CDIRectory <directory\_name>

This command changes the default directory. This directory is used for all subsequent MMEM commands if no path is specified with them. It is also possible to change to a higher directory using two dots '..'.

**Example:** "MMEM:CDIR 'test'"  
 'changes from the current directory level to the subdirectory 'test'.

*RST value	Resolution	SCPI
D:\	-	Compliant

**MMEMory:COPY** <source>[,<destination>]

This command copies the first specified file to the second specified file. Instead of just a file, this command can also be used to copy a complete directory together with all its files.

If <destination> is not specified, <source> is copied to the `MMEM:MSIS` drive and the `MMEM:CDIR` directory. Files which already exist with the same name in the destination directory are overwritten without an error message.

It is also possible to specify the path using another parameter. The command is:

**MMEMory:COPY** <file\_source><msus\_source>[,<file\_destination>,<msus\_destination>]

The command triggers an event and therefore has no query form and no \*RST value.

**Example:** `"MMEM:COPY 'D:\USER\TEST1.SVARCL', 'E: '"`  
 'copies the file 'test1.savrc1' in the USER directory on the internal hard disk to the memory stick without changing the file name.

*RST value	Resolution	SCPI
-	-	Compliant

**MMEMory:DATA** <file\_name>[,<binary block data>]

**MMEMory:DATA?** <file\_name>

This command writes the block data <binary block data> to the file identified by <file\_name>. The IEC/IEEE-bus terminator should be set to EOI in order to ensure correct data transfer.

The associated query command transfers the specified file from the R&S Vector Signal Generator to the IEC/IEEE bus and then on to the control computer. It is important to ensure that the intermediate memory on the control computer is large enough to take the file. In this case, the setting for the IEC/IEEE-bus terminator is irrelevant. This command can be used to read/transfer stored instrument settings or waveforms directly from/to the instrument.

The binary data block has the following structure: #234<block\_data>

# always comes first in the binary block

<number> indicates how many digits the subsequent length entry has (2 in example)

<number> indicates the number of subsequent bytes (34 in example)

<binary block data> binary block data for the specified length

**Example:** `"MMEM:DATA 'TEST1.WV',#3767<binary data>"`  
 'writes the block data to the file 'test1.wv'.

`"MMEM:DATA? 'TEST1.WV'"`  
 'sends the data of the file 'Test1.wv' from the R&S Vector Signal Generator to the control computer in the form of a binary block.

*RST value	Resolution	SCPI
-	-	Compliant



**MMEMemory:DCATalog?** <path>

This command reads out the subdirectories of the specified directory. If no directory is specified, the default directory selected with the `MMEMemory:CDIR` command is read out. The directories are output in a list (the list entries are separated by commas).

The command is a query command and therefore has no \*RST value.

**Example:** `"MMEMemory:DCAT?"`  
 'reads out the subdirectories of the current directory.'

Response: "'test', 'wave', 'digital'"  
 'the subdirectories 'test', 'wave' and 'digital' exist in the current directory.'

*RST value	Resolution	SCPI
-	-	Device-specific

**MMEMemory:DCATalog:LENGth?** <path>

This command reads out the number of subdirectories in the specified directory. If no directory is specified, the directory selected with the `MMEMemory:CDIR` command is read out.

**Example:** `"MMEMemory:DCAT:LENG?"`  
 'reads out the number of subdirectories in the current directory.'

Response: "3"  
 'there are 3 subdirectories in the current directory.'

*RST value	Resolution	SCPI
-	-	Device-specific

**MMEMemory:DELeTe** <file\_name>

This command deletes the specified file.

The command triggers an event and therefore has no query form and no \*RST value.

**Example:** `"MMEMemory:DEL 'D:\USER\TEST1.SAVRCL'"`  
 'deletes the file 'Test1.savrcl' in the USER directory on the internal hard disk.'

*RST value	Resolution	SCPI
-	-	Compliant

**MMEemory:LOAD:STATE** 4,<file\_name>

This command loads the specified file stored under the specified name in an internal memory.

The instrument setting must be activated using an \*RCL command with the number used after the file has been loaded (see the section "Common Commands", page 6.3).

**Example:**        "\*SAV 4"  
                  'stores the current instrument setting in an intermediate memory with number 4.

                  "MMEM:STOR:STAT 4,'D:\user\test4.savrcl'"  
                  'stores the instrument setting stored with the \*SAV command under memory number 4 in the file 'test4.savrcl' in the USER directory on the internal hard disk.

                  "MMEM:LOAD:STAT 4,'D:\user\test4.savrcl'"  
                  'loads the file 'Test4.savrcl' in the USER directory of the internal hard disk.

                  "\*RCL 4"  
                  'activates the instrument setting of the file 'Test4.savrcl'.

*RST value	Resolution	SCPI
-	-	Compliant

**MMEemory:MDIRectory** <directory\_name>

The command creates a new subdirectory in the specified directory. If no directory is specified, a subdirectory is created in the default directory. This command can also be used to create a directory tree.

The command triggers an event and therefore has no query form and no \*RST value.

**Example:**        "MMEM:MDIR 'carrier'"  
                  'creates the subdirectory 'carrier' in the current directory.

*RST value	Resolution	SCPI
-	-	Device-specific

**MMEemory:MOVE** <file\_source>,<file\_destination>

This command renames an existing file if no path is specified for <file\_destination>. Otherwise the file is moved to the specified path and stored under the original file name or, if specified, a new file name. It is also possible to specify the path using another parameter. The command is:

**MMEemory:MOVE** <file\_source><msus\_source>[,<file\_destination>,<msus\_destination>]

The command triggers an event and therefore has no query form and no \*RST value.

**Example:**        "MMEM:MOVE 'test1.savrcl','keep1.savrcl'"  
                  'renames the file 'test1.savrcl' as 'keep1.savrcl'.

                  "MMEM:MOVE 'test1.savrcl','\smu\_one\keep1.savrcl'"  
                  'moves the file 'test1.savrcl' to the subdirectory 'smu\_one' and stores it there under the name 'keep1.savrcl'.

*RST value	Resolution	SCPI
-	-	Compliant

**MMEMemory:MSIS** <msus>

The command sets the drive (or network resource in the case of networks) using <msus> (MSIS = **M**ass **S**torage **I**dentification **S**tring). This setting is effective for all MMEMemory commands where the drive is not explicitly specified in the parameter.

**Example:** "MME:MSIS 'E:'"  
'selects the memory stick as the default drive.

*RST value	Resolution	SCPI
D:\	-	Compliant

**MMEMemory:RDIRectory** <directory\_name>

The command deletes the specified subdirectory in the specified directory. If no directory is specified, the subdirectory with the specified name is deleted in the default directory.

The command triggers an event and therefore has no query form and no \*RST value.

**Example:** "MME:RDIR 'carrier'"  
'deletes the subdirectory 'carrier' in the current directory.

*RST value	Resolution	SCPI
-	-	Device-specific

**MMEMemory:STORe:STATe** 4,<file\_name>

This command stores the current instrument setting in the specified file.

The instrument setting must first be stored in an internal memory with the same number using the common command \*SAV (see the section "Common Commands", page 6.3).

The command triggers an event and therefore has no query form and no \*RST value.

**Example:** "\*SAV 4"  
'stores the current instrument setting in an intermediate memory with number 4. This setting can be called using command \*RCL and the associated number of the memory, e.g. \*RCL 4.

"MME:STOR:STAT 4, 'D:\user\test4.savrcl'"  
'stores the instrument setting stored with the \*SAV command under memory number 4 in the file 'test4.savrcl' in the USER directory on the internal hard disk.

*RST value	Resolution	SCPI
-	-	Compliant

## OUTPut Subsystem

The OUTPut system contains the commands which set the properties of the RF output connectors and USER connectors. The properties of the LF output connector are set in the SOURce:LFOutput system.

Command	Parameters	Default unit	Remark
OUTPut:ALL[:STATe]	ON   OFF		
OUTPut:AFIXed:RANGe:LOWer?		dBm	Query only
OUTPut:AFIXed:RANGe:UPPer?		dBm	Query only
OUTPut:AMODe	AUTO   FIXEd   NORMAl		
OUTPut:BLANK:LIST:STATe	ON   OFF		
OUTPut:BLANK:POLarity	NORMAl   INVerted		
OUTPut:IMPedance		Ohm	Query only
OUTPut:PROTection:CLEar			No query
OUTPut:PROTection:STATe	ON   OFF		
OUTPut:PROTection:TRIPped?			Query only
OUTPut::STATe]	ON   OFF		
OUTPut:[STATe]:PON OUTPut:USER<1...4>:SOURce	OFF   UNCHanged AMARk4   BMARK4   ABLank   BBLank   AHOP   BHOP   ACW   BCW   BBITclock   BBURst   ATRig   BTRig  BSYMbolclock   BATTenuator		

### OUTPut:AFIXed:RANGe:LOWer?

The command queries the minimum level which can be set without the attenuator being adjusted (Attenuator FIXed).

The command is a query and therefore has no \*RST value.

**Example:**           "OUTP:AFIX:RANG:LOW?"  
                          'queries the minimum level for the FIXed setting.  
Response:"-50"  
                          'the minimum level is -50 dBm.

*RST value	Resolution	SCPI
-	-	Device-specific

### OUTPut:AFIXed:RANGe:UPPer?

The command queries the maximum level which can be set without the attenuator being adjusted (Attenuator FIXed).

The command is a query and therefore has no \*RST value.

**Example:**           ":OUTP:AFIX:RANG:UPP?"  
                          'queries the maximum level for the FIXed setting for the RF output.  
Response:"-27"  
                          'the maximum level is -27 dBm.

*RST value	Resolution	SCPI
-	-	Device-specific

**OUTPut:AMODe** AUTO | FIXed | NORMal | HPOWer

The command switches the mode of the attenuator at the RF output (Attenuator MODe).

**Parameters:**     **AUTO**  
 The electronically switching attenuator switches with a 5 dB step width at fixed switching points.

**FIXed**  
 The attenuator is fixed at the current position. The uninterrupted level settings are made if automatic level control is activated (SOURce:POWer:ALC ON).

**Example:**        ": POW:ALC ON"  
                       'activates automatic level control for RF output.  
                       ": POW:ALC ON"  
                       'activates automatic level control for RF output.  
                       "OUTP:AMOD FIX"  
                       'sets the fixed mode with uninterrupted level for RF output.

*RST value	Resolution	SCPI
AUTO	-	Device-specific

**OUTPut:BLANK:LIST:STATE** ON | OFF

The command activates/deactivates RF output blanking.  
 The command is a query and therefore has no \*RST value.

**Example:**        "OUTP:BLAN:LIST:STAT ON"  
                       'activates the RF Output blanking.

*RST value	Resolution	SCPI
ON	-	Device-specific

**OUTPut:BLANK:POLarity** NORMal | INVerted

The command sets the polarity of the No Signal (Blank) Marker.

**Example:**        "OUTP:BLAN:POL NORM"  
                       'causes the No Signal state (settling process in List mode) to be displayed as a result of the high output voltage (HIGH).

*RST value	Resolution	SCPI
NORMal	-	Device-specific

**OUTPut:IMPedance**

The command queries the impedance of the RF outputs. This permits converting the output level between units V and W. The impedances cannot be changed.

The command is a query and therefore has no \*RST value.

**Example:**           ":OUTP:IMP?"  
                          'queries the impedance of RF output.  
Response: "50"  
                          'the impedance is 50 ohms

*RST value	Resolution	SCPI
-	-	Compliant

**OUTPut<[1]|2>:PROTection:CLEar**

The command resets the protective circuit after it has been tripped. The state of the output is again determined by OUTPut:STATe.

If the options R&S -B30 (Path A) and R&S -B25 (Path B) (Overvoltage Protection) are installed for each RF output of the 2.2 and 3 GHz models of the R&S Vector Signal Generator, the outputs are protected by a protective circuit which deactivates the output in the case of an externally applied overvoltage. This does not change the value of OUTPut:STATe.

The command triggers an event and therefore has no reset value.

**Example:**           "OUTP:PROT:CLE"  
                          'resets the protective circuit for RF output A.

*RST value	Resolution	SCPI
-	-	Compliant

**OUTPut:PROTection:STATe ON | OFF**

The command attenuates the RF output signal for about 40 dB to protect external devices against internal signals.

**Example:**           "OUTP:PROT:STAT ON"  
                          'attenuates the RF Output signal for about 40 dB.

*RST value	Resolution	SCPI
OFF	-	Compliant

**OUTPut<[1]|2>:PROTection:TRIPped?**

The command queries the state of the protective circuit.

The command triggers an event and therefore has no reset value.

**Example:**           "OUTP:PROT:TRIP?"  
                          'queries the state of the protective circuit for RF output A.  
Response:"0"  
                          'the protective circuit has not tripped.  
Response:"1"  
                          'the protective circuit has tripped.

*RST value	Resolution	SCPI
-	-	Compliant

**OUTPut:[STATe] ON | OFF**

This command activates and deactivates the RF output.

**Example:**       ":OUTP OFF"  
                  'deactivates the RF output.

*RST value	Resolution	SCPI
-	-	Compliant

**OUTPut:[STATe]:PON OFF | UNCHanged**

This command selects the state which the RF output assumes when the instrument is switched on. The command is an event and therefore has no \*RST value and no query form.

**Parameters:**   **OFF**  
                  The output is deactivated when the instrument is switched on.

**UNCHanged**  
When the instrument is switched on, the output remains in the same state as it was when the instrument was switched off.

**Example:**       "OUTP:PON OFF"  
                  'RF output A is deactivated when the instrument is switched on.

*RST value	Resolution	SCPI
-	-	Device-specific

**OUTPut:USER<1...4>:SOURce AMARk4 | BMArk4 | ABLank | BBLank | AHOP | BHOP | ACW | BCW | BBITclock | BSYMBOLclock | BATTenuator | BBURst | ATRig | BTRig**

The command selects the signal for the specified USER interface.

In case of two-path instruments, the numerical suffix under OUTPut is irrelevant for this command since the USER interfaces are not assigned to any particular path. Some signals which can be applied at the USER interface are permanently assigned, and some are assigned using a dedicated command (e.g. OUTP:CW:SOURce for the CW control signal).

**Example:**       "OUTP:USER2 AMAR"  
                  'causes the marker signal to be output at the USER2 pin of the AUX I/O interface.

                  "OUTP:CLOC:MODE SYMB"  
                  'specifies that the internally generated clock pulse is a symbol clock pulse.

                  "OUTP:CLOC:STAT ON"  
                  'activates output of the symbol clock pulse at the USER2 pin.

*RST value	Resolution	SCPI
USER1 = AMARker4 USER2 = ACW USER3 = ABLank USER4 = ATRig	-	Device-specific

## Power Sensor Measurements - SENSE, READ and INITiate Subsystems

The SENSE subsystem contains the commands for configuring the power measurements with power sensor(s) connected to the generator. The measurement is started and the measurement result retrieved with the READ command. The description of this commands is included in the following.

Up to three sensors can be connected to the signal generator. They are distinguished by means of the suffix under SENSE:

Power sensor connected to the SENSOR port = SENSE[1]

First Power sensor connected to one of the USB interfaces = SENSE 2

Second Power sensor connected to one of the USB interfaces = SENSE 3

Command	Parameters	Default unit	Remark
INITiate<[1]...3>[:POWer]:CONTInuous	ON   OFF		
READ<[1]...3>[:POWer]?			Query only
SENSe<[1]...3>[:POWer]:CORRection:SPDeVice:STATe	ON   OFF		
SENSe<[1]...3>[:POWer]:DISPlay:PERManent:STATe	ON   OFF		
SENSe<[1]...3>[:POWer]:FILTer:LENGTh:AUTO?			Query only
SENSe<[1]...3>[:POWer]:FILTer:LENGTh[:USER]	1 ... 65536		
SENSe<[1]...3>[:POWer]:FILTer:NSRatio	0.0001 ... 1.0		
SENSe<[1]...3>[:POWer]:FILTer:NSRatio.MTIme	1.0 ... 999.99	s	
SENSe<[1]...3>[:POWer]:FILTer:SONCe			No query
SENSe<[1]...3>[:POWer]:FILTer:TYPE	AUTO   USER   NSRatio		
SENSe<[1]...3>[:POWer]:FREQUency	<frequency>	Hz	Range depends on used sensor
SENSe<[1]...3>[:POWer]:OFFSet	-100 ... 100 dB	dB	
SENSe<[1]...3>[:POWer]:OFFSet:STATe	OFF   ON		
SENSe<[1]...3>[:POWer]:SNUMber?			Query only
SENSe<[1]...3>[:POWer]:SOURce	A   B   USER		
SENSe<[1]...3>[:POWer]:STATus[:DEVIce]?			Query only
SENSe<[1]...3>[:POWer]:SVERsion?			Query only
SENSe<[1]...3>[:POWer]:TYPE?			Query only
SENSe<[1]...3>[:POWer]:ZERO?			No Query
SENSe<[1]...3>:UNIT[:POWer]	DBM   DBUV   WATT	DBM	

### INITiate<[1]...3>[:POWer]:CONTInuous

The command switches the local state of the continuous power measurement by the R&S NRP-Zxx power sensors on and off. Switching the local state off enhances the measurement performance during remote control

**Example:**           INIT:CONT  
                              'switches local state of continuous power measurement on.

*RST value	Resolution	SCPI
OFF	-	Device specific



**READ<[1]...3>[POWER]?**

The command triggers the measurement with power sensors and provides the power measurement result of the selected power sensor. The value is provided with the unit set with command `SENSe:UNIT[:POWER]`.

For certain power sensors, e.g. R&S NRP-Z81, two values are returned, first the value for the average level and - separated by a comma - the peak level.

**Note:**

*The local state is not influenced by this commands, measurements results can be retrieved with local state on or off. For long measurement times it is recommended to use a SRQ (MAV bit) for command synchronization.*

The command is a query command and therefore has no \*RST value.

**Example:**

`SENS:UNIT DBM`

'selects unit dBm for presentation of measurement result.

`READ1?`

'queries the measurement result of the sensor connected to the SENSOR interface.

Response: `-45.6246576745440230`

'-45.6 dBm were measured at the given frequency.

or (e.g. for R&S NRP-Z81)

Response: `-55.62403263352178,-22.419472478812476`

'-55,6 dbm is the measured average level, -22.4 dBm is the measured peak level at the given frequency.

*RST value	Resolution	SCPI
-	-	Device specific

**SENSe<[1]...3>[:POWER]:CORRection:SPDevice:STATe ON | OFF**

The command activates the use of the s-parameters correction data of the selected power sensor.

**Example:**

`SENS:POW:CORR:SPD:STAT ON`

'activates the use of the s-parameters correction data of power sensor 1.

*RST value	Resolution	Dependencies	SCPI
OFF	-	For power sensor with attenuator this command is automatically set to ON.	Device specific

**SENSe<[1]...3>[:POWER]:DISPlay:PERManent:STATe ON | OFF**

The command switches on and off the permanent indication of the power measurement result in the upper right corner of the block diagram. For each sensor, the type of sensor, the connector, the measurement source and - if set - the offset is indicated.

**Example:**

`SENS1:POW:DISP:PERM:STAT ON`

'the permanent viewer is switched on.

*RST value	Resolution	SCPI
OFF	-	-

**SENSe<[1]...3>[:POWer]:FILTer:LENGth:AUTO?**

The command queries the current filter length for auto filter mode (:SENSe<[1]...3>:POWer:FILTer:TYPE AUTO)

The command is a query command and therefore has no \*RST value.

**Example:**           SENS1:FILT:TYPE AUTO  
                          'selects auto filter mode for the power sensor connected to the SENSOR connector.

                          SENS1:FILT:LENG:AUTO?  
                          'queries the automatically set filter length.

Response: 1024

*RST value	Resolution	SCPI
	-	Device specific

**SENSe<[1]...3>[:POWer]:FILTer:LENGth[:USER] 1 ... 65536**

The command selects the filter length for user filter mode (:SENSe:POWer:FILTer:TYPE USER). As the filter length works as a multiplier for the time window, a constant filter length results in a constant measurement time. Values 1 and 2<sup>n</sup> are settable.

The time window is fixed to 20 ms.

**Example:**           SENS:FILT:TYPE USER  
                          'selects user filter mode.

                          SENS:FILT:LENG 16  
                          'sets a filter length of 16. The resulting measurement time is 640 ms (2x16x20 ms).

*RST value	Resolution	SCPI
1	-	Device specific

**SENSe<[1]...3>[:POWer]:FILTer:NSRatio 0.0001 ... 1.0**

The command defines the noise content for fixed noise filter mode (:SENSe<[1]...3>:POWer:FILTer:TYPE SNRation). This value determines the proportion of intrinsic noise in the measured result.

**Example:**           SENS1:FILT:TYPE SNR  
                          'selects fixed noise filter mode for the power sensor connected to the SENSOR connector.

                          SENS1:FILT:NSR 0.2  
                          'sets a noise content of 0.2.

*RST value	Resolution	SCPI
0.001	-	Device specific

**SENSe<[1]...3>[:POWer]:FILTer:NSRatio:MTIME 1.0 ... 999.99 s**

The command defines the timeout for fixed noise filter mode (:SENSe<[1]...3>:POWer:FILTer:TYPE SNRation). This value ensures limited settling times.

**Example:**

```
SENS1:FILT:TYPE SNR
    'selects fixed noise filter mode for the power sensor connected to the
    SENSOR connector.

SENS1:FILT:NSR .2
    'sets a noise content of 0.2.

SENS1:FILT:NSR:MTIM 5
    'limits the settling time to 5 seconds
```

*RST value	Resolution	SCPI
4 s	-	Device specific

**SENSe<[1]...3>[:POWer]:FILTer:SONCe**

The command activates the search for the optimum filter length for the current measurement conditions. The found filter length can be retrieved with command :SENSe:POWer:FILTer:LENGth:USER?. This command is only available for user filter mode (:SENSe:POWer:FILTer:TYPE USER).

The command triggers an event and therefore has no \*RST value and no query form.

**Example:**

```
SENS:FILT:TYPE USER
    'selects user filter mode.

SENS:FILT:SONC
    'activates the search for the optimum filter length.

SENS:FILT:LENG?
    'returns the found optimum filter length.

Response: 128
```

*RST value	Resolution	SCPI
-	-	Device specific

**SENSe<[1]...3>[:POWer]:FILTer:TYPE AUTO | USER | NSRatio**

The command selects the filter mode. The filter length is the multiplier for the time window and thus directly influences the measurement time.

**Parameters: AUTO**

The filter length is automatically selected depending on the measured value. For high values, a short filter length is selected and for low values a long filter length is selected.

**USER**

The filter length is set manually. As the filter length works as a multiplier for the measurement time, this results in a constant measurement time.

**SNRatio**

The filter length (averaging factor) is selected so that the sensor's intrinsic noise (2 standard deviations) does not exceed the specified noise content. The desired noise content is entered with command

```
SENSe:FILTer:NSRatio.
```

To avoid very long settling times when the power is low, the averaging factor can be limited with the **Timeout** parameter (command

```
SENSe:FILTer:NSRatio:MTIME).
```

**Example:**       SENS:FILT:TYPE AUTO  
                  'selects automatic filter selection.

*RST value	Resolution	SCPI
AUTO	-	Device specific

**SENSe<[1]...3>[:POWER]:FREQUENCY <frequency>**

The command sets the RF frequency of the source if the user source is selected (SENSe[:POWER]:SOURce USER).

**Example:**       SENS:SOUR USER  
                  'selects user-defined source.

```
SENS:FREQ 2.44 GHz"
'enters the RF frequency of the source which is 2.44 GHz.
```

*RST value	Resolution	SCPI
1 GHz	-	Device specific

**SENSe<[1]...3>[:POWER]:OFFSet -100 ... 100**

The command enters a level offset which is added to the measured level value after activation with command SENSe[:POWER]:OFFSet:STATe ON. This allows e.g. an attenuator in the signal path to be taken into account.

**Example:**       SENS:POW:OFFS 10.0  
                  'sets a level offset of 10 dB

*RST value	Resolution	SCPI
0.0 dB	-	-

**SENSe<[1]...3>[:POWER]:OFFSet:STATe ON | OFF**

The command activates the addition of the level offset to the measured value. The level offset value is set with command SENSe[:POWER]:OFFSet.

**Example:**       SENS1:POW:OFFS 0.4dB  
                  'sets a level offset of 0.4 dB

```
SENS1:POW:OFFS:STAT ON
'a level offset of 0.4 dB is added to the measured value.
```

*RST value	Resolution	SCPI
OFF	-	-

**SENSe<[1]...3>[:POWER]:SNUMBER?**

The command queries the serial number of the sensor.

The command is a query command and therefore has no \*RST value.

**Example:**           "SENS : SNUM?"  
                          'queries the serial number.

*RST value	Resolution	SCPI
-	-	Device specific

**SENSe<[1]...3>[:POWER]:SOURCE A | B | USER**

The command selects the signal source for the measurement. In case of two-path instruments, the RF signal of path A or path B or a user defined source can be selected.

**Example:**           SENS : SOUR A  
                          'selects the RF signal as measurement source. The RF frequency is used as the measurement frequency of the sensor and the corresponding correction factor is used. The level setting of the instrument serves as reference level of the measurement.

*RST value	Resolution	SCPI
A	-	Device specific

**SENSe<[1]...3>[:POWER]:STATus[:DEVICE]?**

The command queries if a sensor is connected (in case of two-path instruments, at the selected port) to the signal generator.

The sensor is selected by suffix **1**, **2** or **3** in key word SENSe or READ of the command header. Suffix 1 denotes the sensor connected to the SENSOR connector, suffix 2 the sensor connected first to one of the USB interfaces and suffix 3 the sensor connected second to one of the USB interfaces.

The command is a query command and therefore has no \*RST value.

**Example:**           SENS : STAT?  
                          'queries if a sensor is connected to the instrument.  
  
Response: 1  
                          'a sensor is connected to the POWER SENSOR interface.

*RST value	Resolution	SCPI
-	-	Device specific

**SENSe<[1]...3>[:POWER]:SVERsion?**

The command queries the software version of the connected R&S NRP power sensor.

**Example:**           SENS : POW : SVER?  
                          'queries the software version of the R&S NRP power sensor.

*RST value	Resolution	SCPI
-	-	-

**SENSe<[1]...3>[:POWER]:TYPE?**

The command queries the type of sensor (in case of two-path instruments, the sensor connected at the selected port is queried). The type is automatically detected.

The command is a query command and therefore has no \*RST value.

**Example:**           "SENS : TYPE?"  
                          'queries the type of sensor connected to the POWER SENSOR connector.

Response: NRP-Z21  
          'the R&S NRP-Z21 sensor is used.

*RST value	Resolution	SCPI
-	-	Device specific

**SENSe<[1]...3>[:POWER]:ZERO**

The command activates the autozero function. Zeroing is required in regular interval (at least once a day) and if the temperature has varied more than about 5 °C, if the sensor has been replaced or if measurements of signals with very low power are to be performed. The RF power source must be switched off or disconnected from the sensor before starting the autozero function.

The command is an event and therefore has no \*RST value.

**Example:**           SENS : ZERO  
                          'activates autozero function.

*RST value	Resolution	SCPI
-	-	Device specific

**SENSe<[1]...3>:UNIT[:POWER] DBM | DBUV | WATT**

The command selects the unit used for result query with command READ. The power sensor provides the measured value in Watt. In which unit the measured value is returned is selected here and might be either Watt, dBm or dBuV.

**Example:**           "SENS2 : UNIT DBM"  
                          'selects unit dBm for the measured value returned by command READ.

READ2?

Response: 7.34  
          '7.34 dBm are measured by sensor 2.

*RST value	Resolution	SCPI
DBM	-	Device specific

## SOURce Subsystem

The SOURce subsystem contains the commands for configuring the digital and analog signals. In the case of two-path channels, the suffix 2 identifies the signals of Path B under SOURce:

Path A = SOURce[1]

Path B = SOURce 2

LF output = SOURce:LFOutput

The keyword SOURce is optional with commands for Path A and the LF output and can be omitted. For Path B, the command must contain the keyword together with the suffix 2.

In case of one-path instruments, the keyword SOURce is optional and can be omitted.

## SOURce:AM Subsystem

The AM subsystem contains the commands for checking the amplitude modulation and also the broadband amplitude modulation. The settings for the internal modulation source (LF generator) are made in the SOURce:LFOutput subsystem.

In the case of two-path instruments with a second RF path, the amplitude modulation can be set separately and independently for the two RF outputs. The suffix under SOURce distinguishes the outputs:

SOURce[1] = RF output A

SOURce2 = RF output B

The keyword SOURce is optional with commands for RF output A and can be omitted. For RF output B, the command must contain the keyword together with the suffix 2.

In case of one-path instruments, the keyword SOURce is optional and can be omitted.

Command	Parameters	Default unit	Remark
[SOURce:]AM:BBANd:SENSitivity?			Query only
[SOURce:]AM:BBANd[:STATe]	ON   OFF		
[SOURce<[1] 2>:]AM[:DEPTH]	0...100 PCT	PCT	
[SOURce<[1] 2>:]AM:EXTernal:COUPling	AC   DC		
[SOURce<[1] 2>:]AM:SENSitivity?			Query only
[SOURce<[1] 2>:]AM:SOURce	EXT   INT   INT, EXT		
[SOURce<[1] 2>:]AM:STATe	ON   OFF		

**[SOURce:]AM:BBANd:SENSitivity?**

The command queries the input sensitivity in V/100% modulation depth.

The command is a query command and therefore has no \*RST value. For two-path instruments, broadband amplitude modulation is only possible for Path A.

**Example:** "AM:BBAN:SENS?"  
'queries the input sensitivity for the BB-AM modulation signal at the I input.

Response: "0.25"  
'the input sensitivity is 0.25 V / 100 % depth.

*RST value	Resolution	SCPI
-	-	Compliant

**[SOURce:]AM:BBANd[:STATe] ON | OFF**

The command activates/deactivates the broadband amplitude modulation. It is not possible to set a modulation depth for BB-AM. The modulation input is the I IN connector. For two-path instruments, broadband amplitude modulation is only possible for Path A.

Activation of broadband amplitude modulation deactivates AM, ARB, I/Q modulation, digital modulation and all digital standards.

**Example:** "AM:BBAN ON"  
'activates BB-AM modulation.

*RST value	Resolution	Correlation	SCPI
OFF	-	AM:BBAN ON deactivates BB-AM, ARB, I/Q modulation, DM and all digital standards.	Compliant

**[SOURce<[1]2>:]AM[:DEPT] 0 ... 100 PCT**

The command sets the modulation depth of the amplitude modulation in percent. The modulation depth is limited by the maximum peak envelope power (PEP).

**Example:** "AM 15PCT"  
'sets the AM modulation depth to 15 percent.

*RST value	Resolution	SCPI
30 PCT	See data sheet	Compliant



**[SOURce<[1]>:]AM:EXTernal:COUpling AC | DC**

The command selects the coupling mode for the external modulation input (EXT MOD) in the case of amplitude modulation.

**Parameters: AC**

The DC voltage component is disconnected from the modulation signal.

**DC**

The modulation signal is not changed.

**Example:**

"AM:EXT:COUP AC"

'selects the coupling mode AC for external amplitude modulation.

*RST value	Resolution	SCPI
AC	-	Compliant

**[SOURce<[1]>:]AM:SENSitivity?**

The command queries the input sensitivity of the EXT MOD input in %/V. The command is only effective if the external modulation source is selected (SOUR:AM:SOUR EXT). The returned value depends on the modulation depth setting (SOUR:AM:DEPTH). This value is assigned to the voltage value for full modulation of the input.

The command is a query command and therefore has no \*RST value.

**Example:**

"AM:DEPT 50"

'sets a modulation depth of 50 %.

"AM:SENS?"

'queries the input sensitivity at the EXT MOD input.

Response: "50"

'since the voltage value for full modulation is 1V, the resulting sensitivity is precisely 50%/V.

*RST value	Resolution	SCPI
-	-	Compliant

**[SOURce<[1]>:]AM:SOURce EXT | INT | INT,EXT**

The command selects the modulation source for amplitude modulation. INT is the LF generator. The frequency of the internal modulation signal can be set in the SOURce:LFOutput subsystem. The external signal is input at the EXT MOD connector. Internal and external modulation source can be selected at the same time.

**Example:**

"AM:SOUR INT"

'selects the internal modulation source.

*RST value	Resolution	SCPI
INTernal	-	Compliant

**[SOURce<[1]|2>:]AM:STATe ON | OFF**

The command activates/deactivates amplitude modulation.

Activation of amplitude modulation deactivates BB-AM, ARB, I/Q modulation, digital modulation and all digital standards.

**Example:** "AM:STAT ON"  
'activates AM modulation.

*RST value	Resolution	Correlation	SCPI
OFF	-	AM ON deactivates BB-AM, ARB, I/Q modulation, DM and all digital standards.	Compliant

## SOURce:AWGN Subsystem

The Source:AWGN subsystem contains the commands for setting the noise generator.

In the case of two-path instruments, the numerical suffix under SOURce distinguishes between noise generation in Path A and Path B.

[ :SOURce<1> ] = Path A

:SOURce2 = Path B

The keyword SOURce is optional with commands for Path A and can be omitted. For Path B, the command must contain the keyword together with the suffix 2.

In case of one-path instruments, the keyword SOURce is optional and can be omitted.

Command	Parameters	Default unit	Remark
[SOURce<[1] 2>:]AWGN:BRATe	400... 250E6 bps		
[SOURce<[1] 2>:]AWGN:BWIDth	1kHz .. 80 MHz	Hz	
[SOURce<[1] 2>:]AWGN:BWIDth:NOISe?			Query only
[SOURce<[1] 2>:]AWGN:BWIDth:RATio	1 ... 80 000		
[SOURce<[1] 2>:]AWGN:CNRatio	-30dB..+30dB	dB	
[SOURce<[1] 2>:]AWGN:DISP:MODE	BB   RF		
[SOURce<[1] 2>:]AWGN:DISP:ORES	DIGital   ANALog		
[SOURce<[1] 2>:]AWGN:ENRatio	<numeric_value>	dB	
[SOURce<[1] 2>:]AWGN:FREQuency:RESult			Query only
[SOURce<[1] 2>:]AWGN:FREQuency:TARGeT	0 ... 50 MHz	Hz	
[SOURce<[1] 2>:]AWGN:MODE	ADD   ONLY   CW		
[SOURce<[1] 2>:]AWGN:POWer:CARRier	<numeric_value>	dBm	
[SOURce<[1] 2>:]AWGN:POWer:MODE	CN   EN		
[SOURce<[1] 2>:]AWGN:POWer:NOISe	<numeric_value>	dBm	
[SOURce<[1] 2>:]AWGN:POWer:NOISe:TOTal			Query only
[SOURce<[1] 2>:]AWGN:POWer:RMODE	CARRier   NOISe		
[SOURce<[1] 2>:]AWGN:POWer:SUM?		dBm	Query only
[SOURce<[1] 2>:]AWGN:POWer:SUM:PEP?		dBm	Query only
[SOURce<[1] 2>:]AWGN:STATe	ON   OFF		

### [SOURce<[1]|2>:]AWGN:BRATe 400... 250E6 bps

This command sets the bit rate which is used for calculation of bit energy to noise power ratio from carrier/noise ratio for **Digital Standard** signals. For **Custom Digital Mod** signals, the bit rate which is used for calculation can be queried with this command. Valid units are bps, kbps and mabps as well as b/s, kb/s and mab/s.

**Example:** "AWGN:BRAT?"  
'queries the bit rate which is used for calculation of the  $E_b/N_0$  value from the C/N value.

*RST value	Resolution	SCPI
100 kbps	0.001 bps	Device-specific

**[SOURce<[1]|2>:AWGN:BWIDth 1 kHz ... 80 MHz**

This command sets the system bandwidth. The noise signal at the level which corresponds to the specified carrier/noise ratio is generated in the bandwidth specified here.

This command is available for modes **Additive Noise** and **Noise Only** (SOUR:AWGN:MODE ADD|ONLY).

**Example:** "AWGN:BWID 10 MHz"  
'sets a system bandwidth of 10 MHz.

*RST value	Resolution	SCPI
3.84 MHz	0.1 kHz	Device-specific

**[SOURce<[1]|2>:AWGN:BWIDth:NOISe?**

This command queries the real noise bandwidth.

This command is available for modes **Additive Noise** and **Noise Only** (SOUR:AWGN:MODE ADD|ONLY). The command is a query command and therefore has no \*RST value.

**Example:** "AWGN:BWID:NOIS?"  
'queries the noise bandwidth.

*RST value	Resolution	SCPI
		Device-specific

**[SOURce<[1]|2>:AWGN:BWIDth:RATio 1.0 ... 80 000.0**

This command sets the ratio of minimum real noise bandwidth to system bandwidth. The overall bandwidth "System BW x Minimum Noise/System BW Ratio" may not exceed 80 MHz. Therefore, the available value range depends on the selected system bandwidth.

This command is available for modes **Additive Noise** and **Noise Only** (SOUR:AWGN:MODE ADD|ONLY).

**Example:** "AWGN:BWID:RAT 2"  
'sets a minimum noise/system bandwidth ratio of 2.

*RST value	Resolution	SCPI
1	0.1	Device-specific

**[SOURce<[1]|2>:AWGN:CNRatio -50 dB ... +30 dB**

This command sets the carrier/interferer ratio. The value range depends on the selected AWGN mode (AWGN:MODE ADD|ONLY|CW).

With **Reference Mode Carrier** (AWGN:POW:RMODE CARRIER) the noise level is adjusted to the set C/N ratio and the carrier level is kept constant.

With **Reference Mode Carrier** (AWGN:POW:RMODE NOISE) the carrier level is adjusted to the set C/N ratio and the noise level is kept constant.

This command is available for modes **Additive Noise** and **CW Interferer** (SOUR:AWGN:MODE ADD|CW).

**Example:** "AWGN:CNR 10"  
'sets a carrier/noise ratio of 10 dB.

*RST value	Resolution	SCPI
0 dB	0.001 dB	Device-specific

**[SOURce<[1]|2>:]AWGN:DISPlay:MODE BB | RF**

Selects the display mode to Bseband or RF.

**Example:** "AWGN:DISP:MODE RF"  
'sets the display mode to RF

*RST value	Resolution	SCPI
RF	-	Device-specific

**[SOURce<[1]|2>:]AWGN:DISP:ORESults ANALog | DIGital**

This command selects the display of output results for the analog (DACIF) or the digital (BBOUT) signal path.

**Note:**

*This command is only available with the option R&S SMx-B18, Baseband Digital I/Q Out. If the instrument is not equipped with this option the parameters of the analog signal path are displayed.*

This command is available for modes **Additive Noise** and **Noise Only** (SOUR:AWGN:MODE ADD|ONLY) and for Display Mode set to Baseband (AWGN:DISP:MODE BB).

**Parameters:** **ANALog**  
The parameters of the analog signal path are displayed.

**DIGital**  
The parameters of the digital signal path are displayed.

**Example:** ":AWGN:MODE ONLY"  
'activates the generation of a pure noise for path A.  
"AWGN:DISP:MODE BB"  
'sets the display mode to Baseband.  
":AWGN:DISP:MODE DIG"  
'displays the output results of the digital signal of path A.

*RST value	Resolution	Options	SCPI
ANAL	-	B13 and K62 Digital Output only with option B18 SOURce2 only with a second option B13 and at least one of the options B9/10/11 or B17	Device-specific

**[SOURce<[1]>:]AWGN:ENRatio -30 dB ... +30 dB**

This command sets the ratio of bit energy to noise power density in **Additive Noise** mode. Depending on the selected reference mode either the noise level (:AWGN:POW:RMODE NOISE) or the carrier level (AWGN:POW:RMODE CARRIER) is adjusted to the set  $E_b/N_0$  ratio.

With **Reference Mode Carrier** (AWGN:POW:RMODE CARRIER) the noise level is adjusted to the set  $E_b/N_0$  ratio and the carrier level is kept constant.

With **Reference Mode Noise** (AWGN:POW:RMODE NOISE) the carrier level is adjusted to the set  $E_b/N_0$  ratio and the noise level is kept constant.

For **Digital Standard** signals, the bit rate used for calculation of  $E_b/N_0$  value from C/N value can be entered with command SOUR:AWGN:BRAT.

For **Custom Digital Mod** signals the bit rate used for calculation of  $E_b/N_0$  value from C/N value is determined by the selected standard (SOURce:BB:DM:STANDARD) and cannot be changed.

**Example:** "AWGN:ENR 10"  
'sets a ratio of bit energy to noise power density of 10 dB.

*RST value	Resolution	SCPI
0 dB	0.001 dB	Device-specific

**[SOURce<[1]>:]AWGN:FREQUENCY:RESulting**

This command queries the actual frequency of the sine in the **CW Interferer** mode. The actual frequency may differ from the desired frequency, since the resolution is limited to 0.7 Hz.

The command is a query command and therefore has no \*RST value.

**Example:** "AWGN:FREQ:RES?"  
'queries the actual frequency of the interfering sine.

*RST value	Resolution	SCPI
		Device-specific

**[SOURce<[1]>:]AWGN:FREQUENCY:TARGet 0 Hz ... +50 MHz**

This command sets the desired frequency of the sine in **CW Interferer** mode (AWGN:MODE CW). The resulting frequency may differ from the desired frequency because of the limited frequency resolution of 0.7 Hz.

**Example:** "AWGN:FREQ:TARG 2kHz"  
'sets a frequency of 2 kHz for the interfering sine.

*RST value	Resolution	SCPI
0 Hz	0.07 Hz	Device-specific

**[SOURce<[1]|2>:AWGN:MODE ADD | ONLY | CW**

This command selects the mode for generating the interfering signal.

**Parameters: ADD**

The AWGN noise signal is added to the baseband signal.

**ONLY**

The pure AWGN noise signal is modulated to the carrier. The connection to the baseband is interrupted.

**CW**

The sine interfering signal is added to the baseband signal.

**Example:**

"AWGN:MODE ONLY"

'activates the generation of a pure noise.

"AWGN:STAT ON"

'switches on the generation of a pure noise.

*RST value	Resolution	SCPI
ADD	-	Device-specific

**[SOURce<[1]|2>:AWGN:POWER:CARRier -145 dBm...20 dBm**

This command either sets or queries the carrier level depending on the selected reference mode.

With **Reference Mode Carrier** (SOUR:AWGN:POW:RMOD CARR), the command sets the carrier level. The level of the noise signal is derived from the entered C/N value.

With **Reference Mode Noise** (SOUR:AWGN:POW:RMOD NOIS), the command queries the carrier level which is derived from the entered C/N value. The noise level is set with command SOUR:AWGN:POW:NOISe.

This command is available for modes **Additive Noise** and **CW Interferer** (SOUR:AWGN:MODE ADD|CW).

**Example:**

"AWGN:POW:CARR 10 dBm"

'sets a carrier level of 10 dB.

*RST value	Resolution	SCPI
- 30 dBm	0.01 dBm	Device-specific

**[SOURce<[1]|2>:AWGN:POWER:MODE CN | EN**

This command selects the mode for setting the noise level.

This command is available for mode **Additive Noise** (SOUR:AWGN:MODE ADD).

**Parameters: CN**

The noise level is set on the basis of the value entered for the carrier/noise ratio (SOUR:AWGN:CNR).

**EN**

The noise level is set on the basis of the value entered for the ratio of bit energy to noise power density (SOUR:AWGN:ENR).

**Example:** "SOUR:AWGN:POW:MODE CN"  
 'the noise level is set on the basis of the value entered for the carrier/noise ratio (SOUR:AWGN:CNR).

*RST value	Resolution	SCPI
CN		Device-specific

**[SOURce<[1]|2>:AWGN:POWer:NOISe -145 dBm...30 dBm**

This command sets or queries the noise level in the system bandwidth depending on the selected modes:

**Additive Noise and CW Interferer mode** (SOUR:AWGN:MODE ADD|CW):

With **Reference Mode Carrier** (SOUR:AWGN:POW:RMOD CARR), the command queries the noise level which is derived from the entered C/N value. The carrier level is set with command SOUR:AWGN:POW:CARRier.

With **Reference Mode Noise** (SOUR:AWGN:POW:RMOD NOIS), the command sets the noise level. The level of the carrier signal is derived from the entered C/N value.

**Noise Only mode**

The command sets the noise level.

**Example:** "SOUR:AWGN:POW:NOIS?"  
 'queries the noise level in the system bandwidth.  
 Response: "10"  
 'the noise level in the system bandwidth is 10 dBm.

*RST value	Resolution	SCPI
- 30 dBm	0.01 dBm	Device-specific

**[SOURce<[1]|2>:AWGN:POWer:NOISe:TOTal?**

This command queries the noise level in the total bandwidth.

The command is a query command and therefore has no \*RST value.

**Example:** "SOUR:AWGN:POW:NOIS:TOT?"  
 'queries the noise level in the total bandwidth.  
 Response: "15"  
 'the noise level in the total bandwidth is 15 dBm.

*RST value	Resolution	SCPI
-	-	Device-specific



**[SOURce<[1]|2>:]AWGN:POWer:RMODe CARRier | NOISe**

This command selects the mode for setting the interfering signal.

This command is available for modes **Additive Noise** and **CW Interferer** (SOUR:AWGN:MODE ADD|CW).

**Parameters:**       **CARRier**  
                             The carrier level is kept constant when the C/N value or Eb/N<sub>0</sub> value is changed. The noise level is adjusted.

**NOISe**  
                             The noise level is kept constant when the C/N value or Eb/N<sub>0</sub> value is changed. The carrier level is adjusted.

**Example:**           "AWGN:MODE ADD"  
                             'selects **Additive Noise** mode.  
                             "AWGN:POW:RMODe NOIS"  
                             'selects **Reference Mode Noise**. The noise level is kept constant when the C/N value or Eb/N<sub>0</sub> value is changed. The carrier level is adjusted.

*RST value	Resolution	SCPI
CARRier		Device-specific

**[SOURce<[1]|2>:]AWGN:POWer:SUM?**

This command queries the overall level of the noise signal plus useful signal.

This command is available for modes **Additive Noise** and **CW Interferer** (SOUR:AWGN:MODE ADD|CW). The command is a query command and therefore has no \*RST value.

**Example:**           " SOUR:AWGN:POW:SUM?"  
                             'queries the overall level of the noise signal plus useful signal.

*RST value	Resolution	SCPI
		Device-specific

**[SOURce<[1]|2>:]AWGN:POWer:SUM:PEP?**

This command queries the peak envelope power of the overall signal comprised of noise signal plus useful signal.

This command is available for modes **Additive Noise** and **CW Interferer** (SOUR:AWGN:MODE ADD|CW). The command is a query command and therefore has no \*RST value.

**Example:**           " SOUR:AWGN:POW:SUM:PEP?"  
                             'queries the peak envelope power of the overall signal.

*RST value	Resolution	SCPI
		Device-specific

**[SOURce<[1]|2>:]AWGN:STATe ON | OFF**

This command activates or deactivates the white noise (AWGN = Averaged White Gaussian Noise). The noise signal is either superimposed on the baseband signal (**Additive Noise** mode (SOUR:AWGN:MODE ADD)) or is output as a pure noise signal (**Noise Only** mode (SOUR:AWGN:MODE ONLY)). In addition, a sine with adjustable frequency offset to the baseband signal can be generated as an RFI signal (**CW Interferer** mode; SOUR:AWGN:MODE CW).

**Example:**           "AWGN:STAT ON"  
                          'activates the RFI signal generator.

*RST value	Resolution	SCPI
OFF	-	Device-specific

## SOURce-BB-MEASurement Subsystem

This subsystem contains the commands for measuring the level values of the digital baseband signal.

### Note:

*Monitoring the measurement of the digital I/Q baseband signal requires the baseboard version "DacBoard 1141.8190.02" or higher. Up to baseboard version DacBoard 1141.8090.xx only the calculated signal levels are provided.*

*The currently equipped DacBoard is listed in the dialog **Setup System Hardware Config**, section **Baseband Assembly**.*

The numeric suffix to SOURce distinguishes between the signal for path A and path B in the case of two-path instruments:

SOURce[1] = Path A

SOURce2 = path B

The keyword SOURce is optional in the case of commands for path A and can be omitted. For path B the command must contain the keyword with suffix 2.

In case of one-path instruments, the keyword SOURce is optional and can be omitted.

Command	Parameters	Default unit	Remark
[SOURce<[1] 2>:]BB:MEASurement:CFACtor?		dB	Query only
[SOURce<[1] 2>:]BB:MEASurement:DURation		"hh:mm:ss"	
[SOURce<[1] 2>:]BB:MEASurement:POWer:PEAK?		dBfs	Query only
[SOURce<[1] 2>:]BB:MEASurement:POWer:RMS?		dBfs	Query only
[SOURce<[1] 2>:]BB:MEASurement:RTIME?		"hh:mm:ss"	Query only
[SOURce<[1] 2>:]BB:MEASurement:SOURce	BB   BAWGn		
[SOURce<[1] 2>:]BB:MEASurement[:STATE]	ON   OFF   1   0		

### [SOURce<[1]|2>:]BB:MEASurement:CFACtor?:

This command indicates the crest factor of the baseband signal during measurement.

The command is a query command and therefore has no \*RST value.

**Example:**           "BB:MEAS:CFAC?"  
                          'queries the measured crest factor of the baseband signal.

*RST value	Resolution	SCPI
-	-	Device-specific

### [SOURce<[1]|2>:]BB:MEASurement:DURation 1 s ... 3 h

This command sets the time for the measurement of the digital I/Q baseband signal in the range of 1 s ... 3 h. The time is to be entered in format "hh:mm:ss".

**Example:**           "BB:MEAS:DUR "00:15:30"  
                          'sets the measurement duration to 15 minutes and 30 seconds.

*RST value	Resolution	SCPI
1 s	-	Device-specific

**[SOURce<[1]|2>:]BB:MEASurement:POWer:PEAK?:**

This command indicates the peak level of the baseband signal relative to full scale of 0.5 V (in terms of dB full scale) during measurement.

The command is a query command and therefore has no \*RST value.

**Example:** "BB:MEAS:POW:PEAK?"  
'queries the peak level of the baseband signal.

*RST value	Resolution	SCPI
-	-	Device-specific

**[SOURce<[1]|2>:]BB:MEASurement:POWer:RMS?:**

This command indicates the rms level of the baseband signal relative to full scale of 0.5 V (in terms of dB full scale) during measurement.

The command is a query command and therefore has no \*RST value.

**Example:** "BB:MEAS:POW:RMS?"  
'queries the rms level of the baseband signal.

*RST value	Resolution	SCPI
-	-	Device-specific

**[SOURce<[1]|2>:]BB:MEASurement:RTIME?:**

This command indicates the remaining time until the measurement of the digital I/Q baseband signal is completed. The time is displayed in format "hh:mm:ss".

The command is a query command and therefore has no \*RST value.

**Example:** "BB:MEAS:RTIM?"  
'queries the remaining measurement duration.

*RST value	Resolution	SCPI
-	-	Device-specific

**[SOURce<[1]|2>:]BB:MEASurement:SOURce BB | BAWGn**

This command selects the signal source for the measurement. The signal level and crest factor can be retrieved either from the interference-free digital I/Q baseband signal or the signal superimposed by the noise generator AWGN.

**Parameters:** **BB (Baseband Signal without AWGN)**  
Selects the measurement of the interference-free baseband signal.

**BAWGn (Baseband with AWGN)**  
Selects the measurement of the baseband signal after an AWGN noise signal is added.

**Example:** "BB:MEAS:SOURC BAWG"  
'selects the measurement of the digital baseband signal interfered with a noise signal.

*RST value	Resolution	SCPI
BB	-	Device-specific

**[SOURCE<[1]>:]BB:MEASurement:STATe ON | OFF**

Activates/deactivates the measurement of the digital I/Q baseband signal.

When activated, information on the peak level, rms level and crest factor are indicated. Additionally the duration of the measurement can be set.

**Example:**           "BB:MEAS:STAT ON"  
                          'starts measuring the real level values of the digital I/Q baseband signal.

*RST value	Resolution	SCPI
OFF	-	Device-specific

### SOURce-BB-POWER Subsystem

This subsystem contains the commands for retrieving the level values of the digital baseband signal.

The numeric suffix to SOURce distinguishes between the signal for path A and path B in the case of two-path instruments:

SOURce[1] = Path A

SOURce2 = path B

The keyword SOURce is optional in the case of commands for path A and can be omitted. For path B the command must contain the keyword with suffix 2.

In case of one-path instruments, the keyword SOURce is optional and can be omitted.

Command	Parameters	Default unit	Remark
[SOURce<[1] 2>:]BB:CFACtor		dB	Query only
[SOURce<[1] 2>:]BB:POWer:PEAK		dBfs	Query only
[SOURce<[1] 2>:]BB:POWer:RMS		dBfs	Query only

#### [SOURce<[1]|2>:]BB:CFACtor?

This command queries the crest factor of the baseband signal.

The command is a query command and therefore has no \*RST value.

**Example:** "BB:CFAC?"  
'queries the crest factor of the baseband signal.

*RST value	Resolution	SCPI
-	-	Device-specific

#### [SOURce<[1]|2>:]BB:POWer:PEAK?

This command queries the peak level of the baseband signal relative to full scale of 0.5 V (in terms of dB full scale).

The command is a query command and therefore has no \*RST value.

**Example:** "BB:POW:PEAK?"  
'queries the peak level of the baseband signal.

*RST value	Resolution	SCPI
-	-	Device-specific

#### [SOURce<[1]|2>:]BB:POWer:RMS?

This command queries the rms level of the baseband signal relative to full scale of 0.5 V (in terms of dB full scale).

The command is a query command and therefore has no \*RST value.

**Example:** "BB:POW:RMS?"  
'queries the rms level of the baseband signal.

*RST value	Resolution	SCPI
-	-	Device-specific

# SOURce:BB Subsystem - Remote-Control Commands

## Introduction - Baseband Remote-Control Commands

This subsystem contains all commands for digital signal generation. It is divided into several subsystems which are described separately.

The following section describes the commands for setting the frequency shift and the phase offset for the signal at the **Baseband** block output and, in case of two-path instruments, the signal routing.

The numeric suffix to SOURce distinguishes between the signal for path A and path B in the case of two-path instruments:

SOURce<1> = path A

SOURce2 = path B

For two-path instruments, the keyword SOURce is optional in the case of commands for path A and can be omitted. For path B the command must contain the keyword with suffix 2.

For one-path instruments, the keyword SOURce is optional and can be omitted.

In this section, all commands for setting or querying the characteristics of the instruments are described.

## Table of Commands - SOURce:BB

Command	Parameter	Default unit	Note
[SOURce<[1] 2>]:BB:F0FFset	<numeric_value>	Hz	
[SOURce]:BB:PATH:COUNT			
[SOURce<[1] 2>]:BB:PGAin	<numeric_value>	dB	
[SOURce<[1] 2>]:BB:POFFset	<numeric_value>	RAD	
[SOURce<[1] 2>]:BB:ROUte	A   B   AB		

### [SOURce<[1]|2>]:BB:F0FFset <numeric\_value>

The command sets the frequency offset for the baseband signal. The offset affects the signal on the **baseband block** output. It shifts the useful baseband signal in the center frequency.

#### Note:

*It is not possible to enter a frequency offset if a waveform with a sample rate of exactly 100 MHz is introduced. A signal of this nature is not routed via the resampler in which the frequency shift takes place. This type of entry is also prohibited if the noise generator (AWGN block) is on.*

The complex I/Q bandwidth of the useful signal must not exceed 80 MHz in total. The following applies:

$$f_{\text{offset}} - \frac{f_{\text{use}}}{2} \geq -40\text{MHz} \quad \text{and} \quad f_{\text{offset}} + \frac{f_{\text{use}}}{2} \leq +40\text{MHz}$$

$f_{\text{use}}$  = the complex useful bandwidth of the I/Q signal before the offset.

$f_{\text{offset}}$  = frequency offset.

**Example:**       ":BB:FOFF 2MHZ"  
                   'sets a frequency offset of 2 MHz.

*RST value	Resolution	SCPI
0 Hz	0.01 Hz	Device-specific

**[SOURce]:BB:PATH:COUNT?**

The command queries the number of installed baseband paths.  
 This command is a query and therefore has no \*RST value.

**Example:**       ":BB:PATH:CONT?"  
                   'queries the number of baseband paths.  
                   Response:"1"  
                   'the instrument is equipped with one baseband path.

*RST value	Resolution	SCPI
	-	Device-specific

**[SOURce<[1]|2>]:BB:PGAin <numeric\_value>**

**Note:**  
*This command is available for two-path instruments only.*

The command sets the relative path gain for the selected baseband signal compared to the baseband signals of the other baseband sources (second path or external baseband). The gain affects the signal on the **baseband block** output.

**Example:**       ":BB:PGA 3dB"  
                   'sets a relative path gain of 3 dB for the baseband signal of path A compared to the baseband signal of path B.

*RST value	Resolution	SCPI
0 dB	0.1 dB	Device-specific

**[SOURce<[1]|2>]:BB:POFFset <numeric\_value>**

**Note:**  
*This command is available for two-path instruments only.*

The command sets the relative phase offset for the selected baseband signal compared to the baseband signals of the other baseband sources (second path or external baseband). The gain affects the signal on the **baseband block** output.

**Example:**       ":BB:POFF 0.5DEG"  
                   'sets a relative phase offset of 0.5 DEG for the baseband signal of path A compared to the baseband signal of path B.

*RST value	Resolution	SCPI
0 DEG	0.1 DEG	Device-specific



[SOURce<[1]|2>]:BB:ROUTe A | B | AB

**Note:**

*This command is available for two-path instruments only.*

The command selects the signal route for the baseband signal of a two-path instrument.

**Parameter:**

**A**

The baseband signal is introduced into path A. The signals from both paths are summed if necessary.

**B**

The baseband signal is introduced into path B. The signals from both paths are summed if necessary.

**AB**

The baseband signal is introduced into path A and path B. The signals from both paths are summed if necessary.

**Example:**

"SOUR2:BB:ROUT A"

'the baseband signal of path B is introduced into path A.

*RST value	Resolution	SCPI
A	-	Device-specific

# SOURce:BB:ARB Subsystem - Remote Control Commands

## Introduction - ARB Remote-Control Commands

**Note:**

The ARB subsystem is available for R&S SMx and R&S AMU instruments only. For R&S WinIQSIM2, the commands regarding the ARB:MCARRier (multi carrier) and ARB:WSEGment (multi segment) are available.

The ARB subsystem contains the commands for setting the ARB Generator.

Settings for clock and trigger interfaces and for external outputs are entered in the SOURce:INPut and SOURce:OUTput subsystems.

The numeric suffix to SOURce distinguishes between signal output for path A and path B in the case of two-path instruments:

SOURce[1] = path A

SOURce2 = path B

For two-path instruments, the keyword SOURce is optional with commands for path A and can be omitted. For path B, the command must include the keyword with the suffix 2.

For one-path instruments, the keyword SOURce is optional and can be omitted.

Section "R&S Signal Generator Waveform and List Format", page 6.100 describes the ARB waveform format and how it is used to transmit waveforms via the IEC bus.

## Table of Commands - ARB

Command	Parameter	Default unit	Note
[SOURce<[1]2>]:BB:ARB:CLOCK	400 Hz ... 100 MHz	-	
[SOURce<[1]2>]:BB:ARB:CLOCK:MODE	SAMPlE   MSAMPlE		
[SOURce<[1]2>]:BB:ARB:CLOCK:MULTIplier	1... 64		
[SOURce<[1]2>]:BB:ARB:CLOCK:SOURce	INTernal   EXTernal		
[SOURce<[1]2>]:BB:ARB:MCARRier:CARRier:COUNT	1 ... 32	-	
[SOURce<[1]2>]:BB:ARB:MCARRier:CARRier<0...31>:DELay	-1s ... +1s	s	
[SOURce<[1]2>]:BB:ARB:MCARRier:CARRier<0...31>:FILE	'file name'		
[SOURce<[1]2>]:BB:ARB:MCARRier:CARRier<0...31>:PHASe	0° ... 360°	RAD	
[SOURce<[1]2>]:BB:ARB:MCARRier:CARRier<0...31>:POWer	-80... 0 dB	dB	
[SOURce<[1]2>]:BB:ARB:MCARRier:CARRier:SPACing	0 Hz...50 MHz	Hz	
[SOURce<[1]2>]:BB:ARB:MCARRier:CARRier<0...31>:STATe	ON   OFF		
[SOURce<[1]2>]:BB:ARB:MCARRier:CFACTOR:MODE	OFF   MAX   MIN		
[SOURce<[1]2>]:BB:ARB:MCARRier:CLOad			No query
[SOURce<[1]2>]:BB:ARB:MCARRier:CLOCK			Query only
[SOURce<[1]2>]:BB:ARB:MCARRier:CREate			No query
[SOURce<[1]2>]:BB:ARB:MCARRier:EDIT:CARRier:DELay[:START]	-1s ... +1s	s	
[SOURce<[1]2>]:BB:ARB:MCARRier:EDIT:CARRier:DELay:STEP	-1s ... +1s	s	

Command	Parameter	Default unit	Note
[SOURce<[1] 2>]:BB:ARB:MCARrier:EDIT:CARRier:EXECute			No query
[SOURce<[1] 2>]:BB:ARB:MCARrier:EDIT:CARRier:FILE	'file name'		
[SOURce<[1] 2>]:BB:ARB:MCARrier:EDIT:CARRier:PHASe[:START]	0...360DEG	RAD	
[SOURce<[1] 2>]:BB:ARB:MCARrier:EDIT:CARRier:PHASe:STEP	-360...360DEG	RAD	
[SOURce<[1] 2>]:BB:ARB:MCARrier:EDIT:CARRier:POWer[:START]	-80 ... 0 dB	dB	
[SOURce<[1] 2>]:BB:ARB:MCARrier:EDIT:CARRier:POWer:STEP	-80 ... 80 dB	dB	
[SOURce<[1] 2>]:BB:ARB:MCARrier:EDIT:CARRier:STARt	<carrier_index>		
[SOURce<[1] 2>]:BB:ARB:MCARrier:EDIT:CARRier:STATe	ON   OFF		
[SOURce<[1] 2>]:BB:ARB:MCARrier:EDIT:CARRier:STOP	<carrier_index>		
[SOURce<[1] 2>]:BB:ARB:MCARrier:OFILe	<file_name>		
[SOURce<[1] 2>]:BB:ARB:MCARrier:PRESet	-		
[SOURce<[1] 2>]:BB:ARB:MCARrier:SAMPles		sample	Query only
[SOURce<[1] 2>]:BB:ARB:MCARrier:SETTing:CATalog			Query only
[SOURce<[1] 2>]:BB:ARB:MCARrier:SETTing:LOAD	<file_name>		
[SOURce<[1] 2>]:BB:ARB:MCARrier:SETTing:STORe	<file_name>		
[SOURce<[1] 2>]:BB:ARB:MCARrier:TIME		s	
[SOURce<[1] 2>]:BB:ARB:MCARrier:TIME:MODE	LONG   SHORT   OFF		
[SOURce<[1] 2>]:BB:ARB:PRESet			No query
[SOURce<[1] 2>]:BB:ARB:SEQuence	AUTO / RETRigger / AAUTO / ARETrigger		
[SOURce<[1] 2>]:BB:ARB:STATe	ON   OFF		
[SOURce<[1] 2>]:BB:ARB:TRIGger:ARM:EXECute			No query
[SOURce<[1] 2>]:BB:ARB:TRIGger:EXECute			No query
[SOURce<[1] 2>]:BB:ARB:TRIGger[:EXTernal<[1] 2>]:DELay	0 ... 2 <sup>32</sup> -1 Samples	-	
[SOURce<[1] 2>]:BB:ARB:TRIGger[:EXTernal<[1] 2>]:INHibit	0 ... 2 <sup>32</sup> -1 Samples	-	
[SOURce<[1] 2>]:BB:ARB:TRIGger:OBASeband:DELay	0 ... 2 <sup>32</sup> -1 Samples	-	
[SOURce<[1] 2>]:BB:ARB:TRIGger:OBASeband:INHibit	0 ... 2 <sup>32</sup> -1 Samples	-	
[SOURce<[1] 2>]:BB:ARB:TRIGger:OUTPut<[1]...4>:DELay	0 ... 2 <sup>20</sup> -1 Samples		
[SOURce<[1] 2>]:BB:ARB:TRIGger:OUTPut:DELay:FIXed	ON   OFF		
[SOURce<[1] 2>]:BB:ARB:TRIGger:OUTPut<[1]...4>:DELay:MAX			Query only
[SOURce<[1] 2>]:BB:ARB:TRIGger:OUTPut<[1]...4>:DELay:MIN?			Query only
[SOURce<[1] 2>]:BB:ARB:TRIGger:OUTPut<[1]...4>:EXECute			No query
[SOURce<[1] 2>]:BB:ARB:TRIGger:OUTPut<[1]...4>:MODE	UNCHanged   RESTart   PULSe   PATtern   RATio		
[SOURce<[1] 2>]:BB:ARB:TRIGger:OUTPut<[1]...4>:OFFTime	1 ... max_wavelength -1 samples		
[SOURce<[1] 2>]:BB:ARB:TRIGger:OUTPut<[1]...4>:ONTime	1 ... max_wavelength -1 samples		
[SOURce<[1] 2>]:BB:ARB:TRIGger:OUTPut<[1]...4>:PATtern	#B0,1 ... #B111...1,32		
[SOURce<[1] 2>]:BB:ARB:TRIGger:OUTPut<[1]...4>:PULSe:DIVider	2...2 <sup>10</sup>		
[SOURce<[1] 2>]:BB:ARB:TRIGger:OUTPut<[1]...4>:PULSe:FREQ			Query only
[SOURce<[1] 2>]:BB:ARB:TRIGger:RMODE			Query only
[SOURce<[1] 2>]:BB:ARB:TRIGger:SLENgth	1 ... 2 <sup>32</sup> -1 Samples		
[SOURce<[1] 2>]:BB:ARB:TRIGger:SLUNit	SAMPle   SEQuence		
[SOURce<[1] 2>]:BB:ARB:TRIGger:SMODE	SAME   NEXT   NSEam		Query only

Command	Parameter	Default unit	Note
[SOURce<[1] 2>]:BB:ARB:TRIGger:SOURce	INTernal   EXTernal   BEXTernal OBASeband		
[SOURce<[1] 2>]:BB:ARB:TSIGnal:SINE:CREate			No query
[SOURce<[1] 2>]:BB:ARB:TSIGnal:SINE:CREate:NAMed	<file_name>		No query
[SOURce<[1] 2>]:BB:ARB:TSIGnal:SINE:FREQuency	100 Hz ... 25 MHz	HZ	
[SOURce<[1] 2>]:BB:ARB:TSIGnal:SINE:PHASe	-180.00 Deg ... + 180.00 Deg	RAD	
[SOURce<[1] 2>]:BB:ARB:TSIGnal:SINE:SAMPlE	3 ... 1000 samples per period		
[SOURce<[1] 2>]:BB:ARB:WAVeform:CATalog?			Query only
[SOURce<[1] 2>]:BB:ARB:WAVeform:CATalog:LENGth?			Query only
[SOURce<[1] 2>]:BB:ARB:WAVeform:DATA	<file_name>[, <block> ]		
[SOURce<[1] 2>]:BB:ARB:WAVeform:DATA?	<file_name>, <tag>		
[SOURce<[1] 2>]:BB:ARB:WAVeform:DELeTe	<name_of_waveform _file>		No query
[SOURce<[1] 2>]:BB:ARB:WAVeform:FREE			Query only
[SOURce<[1] 2>]:BB:ARB:WAVeform:POINts			Query only
[SOURce<[1] 2>]:BB:ARB:WAVeform:SELEct	<name_of_waveform _file>		
[SOURce<[1] 2>]:BB:ARB:WAVeform:TAG?	'comment'   'copyright'   'date'   'lacfilter'   'marker name'   'poweroffset'		
[SOURce<[1] 2>]:BB:ARB:WSEGment			Query only
[SOURce<[1] 2>]:BB:ARB:WSEGment:CLOAd			No query
[SOURce<[1] 2>]:BB:ARB:WSEGment:CONFigure:CATalog			Query only
[SOURce<[1] 2>]:BB:ARB:WSEGment:CONFigure:CLOCK	max Sample Rate ... 100 MHz		
[SOURce<[1] 2>]:BB:ARB:WSEGment:CONFigure:CLOCK:MODE	UNCHanged   HIGHest   USER		
[SOURce<[1] 2>]:BB:ARB:WSEGment:CONFigure:COMMeNT	<string>		
[SOURce<[1] 2>]:BB:ARB:WSEGment:CONFigure:DELeTe			No query
[SOURce<[1] 2>]:BB:ARB:WSEGment:CONFigure:LEVEl[:MODE]	UNCHanged   ERMS		
[SOURce<[1] 2>]:BB:ARB:WSEGment:CONFigure:OFILe	<file_name>		
[SOURce<[1] 2>]:BB:ARB:WSEGment:CONFigure:SEGMeNT:APPend	<file_name>		
[SOURce<[1] 2>]:BB:ARB:WSEGment:CONFigure:SEGMeNT:CATalog			Query only
[SOURce<[1] 2>]:BB:ARB:WSEGment:CONFigure:SELEct	<file_name>		
[SOURce<[1] 2>]:BB:ARB:WSEGment:CREate			No query
[SOURce<[1] 2>]:BB:ARB:WSEGment:NEXT	1 ... 1999		

**[SOURce<[1]|2>]:BB:ARB:CLOCK <numeric\_value>**

The command sets the clock rate in samples. Loading a waveform sets the clock rate that is defined in the waveform tag 'clock'. The command subsequently changes the clock rate; see data sheet for value range.

In the case of an external clock source (selection ARB:CLOCK:SOURce EXTERNAL) the clock for the external source must be entered with this command.

**Example:**       ":BB:ARB:CLOCK:SOUR INT"  
                  'selects the internal clock source for generating waveforms.  
  
                  ":BB:ARB:CLOCK 0.5 MHz"  
                  'sets the clock rate to 0.5 MHz.

*RST value	Resolution	Dependency	SCPI
1 MHz	0.001 Hz	Loading a waveform (ARB:WAV:SEL <name>) automatically sets the clock rate to the allocated value.	Device-specific

**[SOURce<[1]|2>]:BB:ARB:CLOCK:MODE SAMPlE | MSAMPlE**

The command enters the type of externally supplied clock (:BB:ARB:CLOCK:SOURce EXTERNAL). When MSAMPlE is used, a multiple of the sample clock is supplied via the CLOCK connector and the sample clock is derived internally from this. The multiplier is entered with the command :BB:ARB:CLOCK:MULTIPLIER.

For two-path instruments, the only numerical suffix allowed for SOURce is 1, since the external clock source is permanently allocated to path A.

**Example:**       ":BB:ARB:CLOCK:MODE SAMP"  
                  'selects clock type **Sample**, i.e. the supplied clock is a sample clock.

*RST value	Resolution	SCPI
SAMPle	-	Device-specific

**[SOURce<[1]|2>]:BB:ARB:CLOCK:MULTIPLIER 1 ... 64**

The command specifies the multiplier for clock type **Multiple Samples** (:BB:ARB:CLOCK:MODE MSAM) in the case of an external clock source.

For two-path instruments, the only numerical suffix allowed for SOURce is 1, since the external clock source is permanently allocated to path A.

**Example:**       ":BB:ARB:CLOCK:SOUR EXT"  
                  'selects the external clock source. The clock is supplied via the CLOCK connector.  
  
                  ":BB:ARB:CLOCK:MODE MSAM"  
                  'selects clock type **Multiple Samples**, i.e. the supplied clock has a rate which is a multiple of the sample rate.  
  
                  ":BB:ARB:CLOCK:MULT 12"  
                  'the multiplier for the external clock rate is 12.

*RST value	Resolution	SCPI
4	1	Device-specific

**[SOURce<[1]|2>]:BB:ARB:CLOCK:SOURce INTernal | EXTernal**

The command selects the source for the digital modulation clock.

**Parameter:**       **INTernal**  
                           The internal clock reference is used.

**EXTernal**  
                           The external clock reference is supplied to the CLOCK connector.

**Example:**        ":BB:ARB:CLOC:SOUR EXT"  
                           'selects an external clock reference. The clock is supplied via the CLOCK connector.

":BB:ARB:CLOC:MODE SAMP"  
                           'enters clock type sample.

*RST value	Resolution	SCPI
INTernal		Device-specific

**[SOURce<[1]|2>]:BB:ARB:MCARrier:CARRier:COUNT 1 ... 32**

The command sets the number of carriers in the ARB multi carrier waveform. The total bandwidth (*Number of carriers - 1*) \* *Carrier spacing* is 80 MHz. The number of carriers entered therefore defines the maximum carrier spacing (:BB:ARB:MCARrier:CARRier:SPACing).

**Example:**        ":BB:ARB:MCAR:CARR:COUN 10"  
                           'sets 10 carriers for the multi carrier waveform.

*RST value	Resolution	Dependencies	SCPI
1	1	The carrier spacing (:BB:ARB:MCAR:CARR:SPAC) is reduced if the total bandwidth of 80 MHz is not respected when entering the number of carriers.	Device-specific

**[SOURce<[1]|2>]:BB:ARB:MCARrier:CARRier<0...31>:DELay -1s ... +1s.**

The command sets the start delay of the selected carrier.

**Example:**        ":BB:ARB:MCAR:CARR15:DEL 5us"  
                           'sets a start delay of 50 us for carrier 15.

*RST value	Resolution	SCPI
0 s	1 ns	Device-specific

**[SOURce<[1]|2>]:BB:ARB:MCARrier:CARRier<0...31>:FILE "file name"**

The command selects the file with I/Q data to be modulated onto the selected carrier.

**Example:**        ":BB:ARB:MCAR:CARR15:FILE 'D:\IQ\_wcdma'"  
                           'selects file 'IQ\_wcdma'. The data of the file is modulated onto carrier 15.

*RST value	Resolution	SCPI
-	-	Device-specific

**[SOURce<[1]>]:BB:ARB:MCARrier:CARRier<0...31>:PHASe** 0 ... 360 DEG.

The command sets the start phase of the selected carrier.

The phase settings are only valid if optimization of the crest factor is disabled

(:SOURce:BB:ARB:MCARrier:CFACTOR:MODE OFF).

**Example:**       ":BB:ARB:MCAR:CARR15:PHAS 90 DEG"  
                  'sets a start phase of 90° for carrier 15.

*RST value	Resolution	SCPI
0 DEG	0.01 DEG	Device-specific

**[SOURce<[1]>]:BB:ARB:MCARrier:CARRier<0...31>:POWER** 80 dB ... 0 dB

The command sets the gain of the selected carrier.

**Example:**       ":BB:ARB:MCAR:CARR15:POW -50 dB"  
                  'sets the power of carrier 15 to -50 dB.

*RST value	Resolution	SCPI
0 dB	0.01 dB	Device-specific

**[SOURce<[1]>]:BB:ARB:MCARrier:CARRier:SPACing** 0 Hz ... 50 MHz

The command sets the frequency spacing between adjacent carriers of the multi carrier waveform.

The carriers are generated symmetrically around the RF carrier. The maximum carrier spacing is limited to  $Carrier\ spacing = Total\ baseband\ bandwidth / (Number\ of\ carriers - 1)$ . The total baseband bandwidth is 80 MHz.

**Note:**

*In order to avoid wrap-around problems, the effective **Carrier Spacing** might be slightly modified. The **Carrier Spacing** is rounded in that way that the carrier closest to the center RF frequency shows no phase jump assuming that the carrier is unmodulated.*

*For odd number of carriers:*

*RoundedCarrierSpacing=1/OutputSignalDuration\*round(CarrierSpacing \* OutputSignalDuration);*

*For even number of carriers:*

*RoundedCarrierSpacing=2/OutputSignalDuration\*round(0.5 \*CarrierSpacing \* OutputSignalDuration);*

**Example:**       ":BB:ARB:MCAR:CARR:SPAC 10 MHz"  
                  'sets a carrier spacing of 10 MHz.

*RST value	Resolution	Dependencies	SCPI
10 kHz	0.01 Hz	The maximum carrier spacing is automatically reduced so that the maximum total bandwidth of 80 MHz is not exceeded on entering the number of carriers (:BB:ARB:MCAR:CARR:COUN).	Device-specific

**[SOURce<[1]|2>]:BB:ARB:MCARrier:CARRier<0...31>:STATe ON | OFF**

The command switches the selected carrier on or off.

**Example:**           ":BB:ARB:MCAR:CARR15:STAT ON"  
                  'switches carrier 15 on.

*RST value	Resolution	SCPI
ON	-	Device-specific

**[SOURce<[1]|2>]:BB:ARB:MCARrier:CFACTOR:MODE OFF | MIN | MAX**

The command sets the mode for optimizing the crest factor by calculating the carrier phases.

**Parameter: OFF**  
There is no automatic setting for minimizing or maximizing the crest factor. The **Phase** setting (command BB:ARB:MCAR:CARR:PHAS) is in use.

**MIN**  
The crest factor is minimized by internally calculating optimized carrier phases. The Phase setting (command BB:ARB:MCAR:CARR:PHAS) is invalid.

**MAX**  
The crest factor is maximized by internally calculating optimized carrier phases. The Phase setting (command BB:ARB:MCAR:CARR:PHAS) is invalid.

**Example:**           ":BB:ARB:MCAR:CFACTOR:MODE OFF"  
                  'switches off automatic crest factor optimization. The setting SOUR:BB:ARB:MCAR:CARR:PHAS has an effect.

*RST value	Resolution	SCPI
OFF	-	Device-specific

**[SOURce<[1]|2>]:BB:ARB:MCARrier:CLOAD <file\_name>**

This command creates a multi carrier waveform using the current entries of the carrier table. This multi carrier waveform is saved with the file name specified with command SOUR:BB:ARB:MCAR:OFIL . The file extension is \*. **wv**. Digital standard **ARB** is activated, the new multi carrier waveform is loaded and is output in accordance to the trigger settings. This command triggers an event and therefore has no \*RST value and no query form.

**Example:**           "MMEM:CDIR 'D:\user\waveform"  
                  'sets the default directory to D:\user\waveform.  
                  ":BB:ARB:MCAR:OFIL 'mcar1\_2'"  
                  'defines the file name mcar1\_2.wv for the multi carrier waveform.  
                  ":BB:ARB:MCAR:CLOAD"  
                  'creates multi carrier waveform mcar1\_2.wv.  
                  The new multi carrier waveform is loaded and digital standard **ARB** is activated.

*RST value	Dependencies	SCPI
-	SOUR:BB:ARB:WAV:SEL = <new Waveform> SOUR:BB:ARB:STATe = ON	device-specific



**[SOURce<[1]>]:BB:ARB:MCARrier:CLOCK**

The command queries the resulting sample rate at which the multi carrier waveform is output by the arbitrary waveform generator. The output clock rate depends on the number of carriers, carrier spacing and input sample rate of the leftmost or rightmost carriers.

The command is a query command and therefore has no \*RST value.

**Example:**           ":BB:ARB:MCAR:CLOC?"  
                      'queries the ARB multi carrier output clock rate.

*RST value	Resolution	SCPI
-	-	Device-specific

**[SOURce<[1]>]:BB:ARB:MCARrier:CREate**

This command creates a multi carrier waveform using the current settings of the carrier table. The multi carrier waveform is saved into the file defined with command `SOUR:BB:ARB:MCAR:OFIL`. The file extension is \*. **wv**.

This command triggers an event and therefore has no \*RST value and no query form.

**Example:**           "MMEM:CDIR 'D:\user\waveform'"  
                      'sets the default directory to D:\user\waveform.  
  
                      ":BB:ARB:MCAR:OFIL 'multi\_wv1'"  
                      'defines the file name multi\_wv1.wv for the multi carrier waveform.  
  
                      ":BB:ARB:MCAR:CRE"  
                      'creates multi carrier waveform multi\_wv1.wv.

*RST value	Resolution	SCPI
-	-	device-specific

**[SOURce<[1]>]:BB:ARB:MCARrier:EDIT:CARRier:DELay[:START] -1s ... +1s**

The command sets the start delay for the individual carriers in the defined carrier range. If the command `:BB:ARB:MCAR:EDIT:CARR:DEL:STEP` is used to define a step width, the delay entered here applies only to the starting carrier. The delays of the remaining carriers are stepped up or down by the delay value specified in the `:BB:ARB:MCAR:EDIT:CARR:DEL:STEP` command.

**Example:**           ":BB:ARB:MCAR:EDIT:CARR:DEL 5us"  
                      'sets a start delay of 5 us for the carriers in the carrier range.

*RST value	Resolution	SCPI
0 s	1 ns	Device-specific

**[SOURCE<[1]]2>:BB:ARB:MCARRIER:EDIT:CARRIER:DELAY:STEP -1s ... +1s**

The command sets the step width by which the start delays of the carriers in the defined carrier range will be incremented.

- Example:**       ":BB:ARB:MCAR:EDIT:CARR:DEL 5 us"  
                   'sets a start delay of 5 us for the carriers in the carrier range.
- ":BB:ARB:MCAR:EDIT:CARR:DEL:STEP 1 us"  
                   'the start delay is incremented by 1us for each carrier, i.e. the first carrier has a start delay of 5us, the second a start delay of 6 us, etc.

*RST value	Resolution	SCPI
0s	1 ns	Device-specific

**[SOURCE<[1]]2>:BB:ARB:MCARRIER:EDIT:CARRIER:EXECUTE**

The command adopts the settings for the carrier range which has been defined using the :BB:ARB:MCAR:EDIT:CARR: . . . commands.

- Example:**       ":BB:ARB:MCAR:EDIT:CARR:STAR 4"  
                   'the carrier range starts at carrier 2.
- ":BB:ARB:MCAR:EDIT:CARR:STOP 20"  
                   'the carrier range stops at carrier 20.
- ":BB:ARB:MCAR:EDIT:CARR:STAT ON"  
                   'sets all the carriers in the carrier range (2 to 20) to ON.
- ":BB:ARB:MCAR:EDIT:CARR:EXEC"  
                   'transfers the assistant settings for carrier 2 to 20 into the carrier table.

*RST value	Resolution	SCPI
		Device-specific

**[SOURCE<[1]]2>:BB:ARB:MCARRIER:EDIT:CARRIER:FILE "file name"**

The command selects the input file with I/Q data to be modulated onto the carriers in the defined carrier range.

- Example:**       ":BB:ARB:MCAR:EDIT:CARR:FILE 'D:\IQ\_wcdma'"  
                   'selects input file 'IQ\_wcdma' The data of the file are modulated onto the carriers in the defined carrier range.

*RST value	Resolution	SCPI
-	-	Device-specific

**[SOURCE<[1]]2>:BB:ARB:MCARRIER:EDIT:CARRIER:PHASE[:START] 0 ... 360 DEG.**

The command sets the start phase for the individual carriers in the defined carrier range. If the command :BB:ARB:MCAR:EDIT:CARR:PHAS:STEP is used to define a step width, the phase entered here applies only to the starting carrier. The phases of the remaining carriers are stepped up or down by the phase value specified in the :BB:ARB:MCAR:EDIT:CARR:PHAS:STEP command.

The phase settings are only valid if optimization of the crest factor is disabled (:SOURCE:BB:ARB:MCARRIER:CFACTOR:MODE OFF).

**Example:**       "`:BB:ARB:MCAR:EDIT:CARR:PHAS 90 DEG`"  
                   'sets a start phase of 90° for the carriers in the carrier range.

*RST value	Resolution	SCPI
0 DEG	0.01 DEG	Device-specific

#### [SOURce<[1]|2>]:BB:ARB:MCARrier:EDIT:CARRier:PHASe:STEP 0 ... 360 DEG.

The command sets the step width by which the start phases of the carriers in the defined carrier range will be incremented.

The phase settings are only valid if optimization of the crest factor is disabled

(`:SOURce:BB:ARB:MCARrier:CFACTOR:MODE OFF`).

**Example:**       "`:BB:ARB:MCAR:EDIT:CARR:PHAS 90 DEG`"  
                   'sets a start phase of 90° for the carriers in the carrier range.

"`:BB:ARB:MCAR:EDIT:CARR:PHAS:STEP 1 DEG`"  
   'the start phase is incremented by 1° for each carrier, i.e. the first carrier has a start phase of 90°, the second a start phase of 91°, etc.

*RST value	Resolution	SCPI
0 DEG	0.01 DEG	Device-specific

#### [SOURce<[1]|2>]:BB:ARB:MCARrier:EDIT:CARRier:POWER[:START] 80 dB ... 0 dB

The command sets the power for the individual carriers in the defined carrier range. If the command `:BB:ARB:MCAR:EDIT:CARR:POW:STEP` is used to define a step width, the power entered here applies only to the starting carrier. The power of the remaining carriers is stepped up or down by the power specified in the `:BB:ARB:MCAR:EDIT:CARR:POW:STEP` command.

**Example:**       "`:BB:ARB:MCAR:EDIT:CARR:POW -50 dB`"  
                   'sets the power of the carriers in the carrier range to -50 dB.

*RST value	Resolution	SCPI
0 dB	0.01 dB	Device-specific

#### [SOURce<[1]|2>]:BB:ARB:MCARrier:EDIT:CARRier:POWER:STEP - 80 dB ... +80 dB.

The command sets the step width by which the starting power of the carriers in the defined carrier range will be incremented.

**Example:**       "`:BB:ARB:MCAR:EDIT:CARR:POW -80dB`"  
                   'sets a power of -80 dB for the carriers in the carrier range.

"`:BB:ARB:MCAR:EDIT:CARR:POW:STEP 1 dB`"  
   'the power is incremented by 1dB for each carrier, i.e. the first carrier has -80dB, the second -79dB, etc.

*RST value	Resolution	SCPI
0 dB	0.01 dB	Device-specific

**[SOURCE<[1]>]:BB:ARB:MCARrier:EDIT:CARRier:START <carrier\_index>**

The command selects the first carrier in the carrier range to which the settings with the SOUR:BB:ARB:MCAR:EDIT:CARR:.. commands shall apply.

**Example:** " :BB:ARB:MCAR:EDIT:CARR:STAR 1 "  
'the carrier range starts at carrier 1.

*RST value	Resolution	SCPI
0		Device-specific

**[SOURCE<[1]>]:BB:ARB:MCARrier:EDIT:CARRier:STATe ON | OFF**

The command switches all the carriers in the selected carrier range on or off.

**Example:** " :BB:ARB:MCAR:EDIT:CARR:STAT ON "  
'sets all the carriers in the carrier range to ON.

*RST value	Resolution	SCPI
ON	-	Device-specific

**[SOURCE<[1]>]:BB:ARB:MCARrier:EDIT:CARRier:STOP <carrier\_index>**

The command selects the last carrier in the carrier range to which the settings with the :BB:ARB:MCAR:EDIT:CARR:.. commands shall apply.

**Example:** " :BB:ARB:MCAR:EDIT:CARR:STOP 4 "  
'the carrier range stops at carrier 4.

*RST value	Resolution	SCPI
0		Device-specific

**[SOURCE<[1]>]:BB:ARB:MCARrier:OFILe <file\_name>**

This command defines the output file name for the multi carrier waveform. This file name is used when a waveform is calculated (command SOUR:BB:ARB:MCAR:CLOad or SOUR:BB:ARB:MCAR:CREate). The file extension is \*.wv.

This command triggers an event and therefore has no \*RST value and no query form.

**Example:** "MMEM:CDIR 'D:\user\waveform"  
'sets the default directory to D:\user\waveform.  
" :BB:ARB:MCAR:OFIL 'mcar1\_2' "  
'defines the file name mcar1\_2.wv for the multi carrier waveform file

*RST value	Resolution	SCPI
-	-	device-specific

**[SOURce<[1]|2>]:BB:ARB:MCARrier:PRESet**

The command sets all ARB multi carrier parameters to their default values.  
 This command triggers an event and therefore has no \*RST value and no query form.

**Example:**           ": BB : ARB : MCAR : PRES"  
                   'resets the ARB multi carrier parameters to default values.'

*RST value	Dependency	SCPI
-	SOUR:BB:ARB:MCAR:COUN SOUR:BB:ARB:MCAR:SPAC	0 0
		Device-specific

**[SOURce<[1]|2>]:BB:ARB:MCARrier:SAMPles**

The command queries the resulting file size. The file size is returned in samples.  
 This command is a query and therefore has no \*RST value.

**Example:**           ": BB : ARB : MCAR : SAMP?"  
                   'queries the file size of the currently calculated multi carrier waveform.'

*RST value	Resolution	SCPI
-	-	Device-specific

**[SOURce<[1]|2>]:BB:ARB:MCARrier:SETTing:CATalog?**

This command queries the available settings files in the specified default directory. The settings files are used to set the ARB multi carrier submenu. Only files with the file extension \*.arb\_multcarr will be listed.

The command is a query command and therefore has no \*RST value.

**Example:**           "MMEM:CDIR 'D:\user\waveform"  
                   'sets the default directory to D:\user\waveform.'  
                   ": BB : ARB : MCAR : SETT : CAT?"  
                   'reads out all the settings files in the default directory.'  
                   Response: "mcar1, mcar2"  
                   'the directory D:\user\waveform contains the configuration files  
                   'mcar1.arb\_multcarr' and 'mcar2.arb\_multcarr'.'

*RST value	Resolution	SCPI
-	-	device-specific

**[SOURce<[1]|2>]:BB:ARB:MCARrier:SETTing:LOAD <file\_name>**

The command loads the settings file in the default directory. A path can also be specified, in which case the files in the specified directory are selected. If a settings file with the specified name does not yet exist, it is created. The file extension may be omitted. Only files with the file extension \*.arb\_multcarr will be loaded or created.

**Example:**           "MMEM:CDIR 'D:\user\waveform"  
                   'sets the default directory to D:\user\waveform.'  
                   ": BB : ARB : MCAR : SETT : LOAD 'new'"  
                   'creates settings file new.arb\_multcarr in the default directory.'

*RST value	Resolution	SCPI
-	-	device-specific

**[SOURCE<[1]>]:BB:ARB:MCARRIER:SETTING:STORE <file\_name>**

The command stores the current settings of submenu **ARB Multi Carrier** in a file in the default directory. A path can also be specified, in which case the files are stored in the specified directory. The file extension may be omitted, the files are stored with the file extension **\*.arb\_multcarr**.

**Example:** "MMEM:CDIR 'D:\user\waveform"  
'sets the default directory to D:\user\waveform.  
":BB:ARB:MCAR:SETT:STOR 'mcarr2'"  
'stores settings file mcarr2.arb\_multcarr in the default directory.

*RST value	Resolution	SCPI
-	-	device-specific

**[SOURCE<[1]>]:BB:ARB:MCARRIER:TIME 1E-12s ... 1E9s**

The command sets the user-defined signal period. This setting is only possible for Signal Period Mode User (BB:ARB:MCAR:TIME:MODE USER).

**Example:** ":BB:ARB:MCAR:TIME:MODE USER"  
'selects Signal Period Mode User.  
":BB:ARB:MCAR:TIME 10 s"  
'sets a signal period of 10 seconds

*RST value	Resolution	SCPI
0		device-specific

**[SOURCE<[1]>]:BB:ARB:MCARRIER:TIME:MODE LONG | SHORT | USER**

The command selects the mode for calculating the resulting signal period of the multi carrier waveform. The resulting period is always calculated for all carriers in the carrier table irrespective of their state (ON/OFF).

**Parameter: LONG**  
The resulting signal period is defined by the longest I/Q file in the carrier table. Shorter I/Q files are periodically repeated.

**SHORT**  
The resulting signal period is defined by the shortest I/Q file in the carrier table. Only the first part of longer I/Q files is used.

**USER**  
The signal period can be set with command SOUR:BB:ARB:MCARr:TIME. Shorter I/Q files are repeated periodically, and only the first part of longer I/Q files is used.

**Example:** ":BB:ARB:MCAR:TIME:MODE LONG"  
'selects signal period mode long

*RST value	Resolution	SCPI
LONG	-	device-specific

**[SOURce<[1]|2>]:BB:ARB:PRESet**

The command sets all ARB generator parameters to their default values.

This command triggers an event and therefore has no \*RST value and no query form.

**Example:** " :BB:ARB:PRESet"  
'resets the ARB generator to default values.

*RST value	Dependency	SCPI
-	SOUR:BB:ARB:CLOC 1MHz	Device-specific
	SOUR:BB:ARB:CLOC:DEL 0	
	SOUR:BB:ARB:CLOC:SOUR INT	
	SOUR:BB:ARB:SIGN:FREQ 1 kHz	
	SOUR:BB:ARB:SIGN:POFF 90 DEG	
	SOUR:BB:ARB:SIGN:SAMPL 100	
	SOUR:BB:ARB:STAT OFF	
	SOUR:BB:ARB:TRIG:EXT:DEL 0	
	SOUR:BB:ARB:TRIG:EXT:INH 0	
	SOUR:BB:ARB:TRIG:OUTP<n>:STAT OFF	
	SOUR:BB:ARB:TRIG:OUTP<n>:SHIF 0	
	SOUR:BB:ARB:TRIG:OUTP<n>:MODE REST	
	SOUR:BB:ARB:TRIG:OUTP<n>:PFR 1MHz	
	SOUR:BB:ARB:TRIG:OUTP<n>:PATT #H0,1	
	SOUR:BB:ARB:TRIG:OUTP<n>:OFFT 1	
	SOUR:BB:ARB:TRIG:OUTP<n>:ONT 1	
	SOUR:BB:ARB:TRIG:SEQ AUTO	
	SOUR:BB:ARB:TRIG:SOUR INT	

**[SOURce<[1]|2>]:BB:ARB:SEQuence** AUTO | RETRigger | AAUTo | ARETrigger | SINGLE

The command selects the trigger mode.

**Parameter: AUTO**  
The waveform is output continuously.

**RETRigger**  
The waveform is output continuously. A trigger event (internal or external) causes a restart.

**AAUTo**  
The waveform is output only when a trigger event occurs. After the trigger event the waveform is output continuously. Waveform output is stopped with command SOUR:BB:ARB:TRIG:ARM:EXEC and started again when a trigger event occurs.

**ARETrigger**  
The waveform is output only when a trigger event occurs. The device automatically toggles to RETRIG mode. Every subsequent trigger event causes a restart. Waveform output is stopped with command SOUR:BB:ARB:TRIG:ARM:EXEC and started again when a trigger event occurs.

**SINGle**  
The waveform is output only when a trigger event occurs. After the trigger event the waveform is output once to the set sequence length (SOUR:BB:ARB:TRIG:SLen). Every subsequent trigger event causes a restart.

**Example:** " :BB:ARB:SEQ AAUT"  
'sets the **Armed\_auto** trigger mode; the device waits for the first trigger (e.g. with \*TRG) and then generates the signal continuously.

*RST value	Resolution	SCPI
RETRigger	-	Device-specific

**[SOURCE<[1]>]:BB:ARB:STATe ON | OFF**

The command switches the ARB generator on. Any other standards or digital modulation that may be in the ON state are automatically turned OFF. ARB:STAT ON is only possible after the selection of a waveform. The selected waveform is output straight away (ARB:SEQ AUTO|RETRigger) or after the first trigger event (ARB:SEQ AAUT|ARET), depending on the trigger setting.

**Example:**       ":BB:ARB:WAV:SEL 'wave1'"  
                   'loads waveform file 'wave1.wv' from the default directory.

                  ":BB:ARB:TRIG:SEQ RETR"  
                   'sets trigger mode Retrigger.

                  ":BB:ARB:STAT ON"  
                   'switches on the ARB generator. The selected waveform is output straight away. A trigger event causes signal output to restart.

*RST value	Resolution	Dependency	SCPI
OFF	-	ARB:STAT ON switches off other standards and digital modulation on (in case of two-path instruments, this affects the same path).	Device-specific

**[SOURCE<[1]>]:BB:ARB:TRIGger:ARM:EXECute**

The command stops waveform output for trigger modes Armed\_Auto and Armed\_Retrigger. A subsequent internal or external trigger event restart waveform output.

This command triggers an event and therefore has no \*RST value and no query form.

**Example:**       ":BB:ARB:TRIG:SOUR INT"  
                   'sets internal triggering.

                  ":BB:ARB:TRIG:SEQ ARET"  
                   'sets Armed\_Retrigger mode, i.e. every trigger event causes waveform output to restart.

                  ":BB:ARB:TRIG:EXEC"  
                   'executes a trigger, waveform output is started.

                  ":BB:ARB:TRIG:ARM:EXEC"  
                   'waveform output is stopped.

                  ":BB:ARB:TRIG:EXEC"  
                   'executes a trigger, waveform output is started again.

*RST value	Resolution	SCPI
-	-	Device-specific



**[SOURce<[1]|2>]:BB:ARB:TRIGger:EXECute**

The command executes a trigger. The internal trigger source must be selected using the command `ARB:TRIGger:SOURce INTernal` and a trigger mode other than `AUTO` must be selected using the command `:ARB:SEQuence`.

This command triggers an event and therefore has no `*RST` value and no query form.

**Example:**       `" :BB:ARB:TRIG:SOUR INT "`  
                      'sets internal triggering.

`" :BB:ARB:SEQ RETR "`  
                      'sets Retrigger mode, i.e. every trigger event causes signal output to restart.

`" :BB:ARB:TRIG:EXEC "`  
                      'executes a trigger.

*RST value	Resolution	SCPI
-	-	Device-specific

**[SOURce<[1]|2>]:BB:ARB:TRIGger[:EXTernal<[1]|2>]:DELay 0 ... 2<sup>32</sup>-1 samples**

The command specifies the trigger delay (expressed as a number of samples) for external triggering. The numeric suffix to `EXTernal` distinguishes between the external trigger via the TRIGGER 1 (suffix 1) and TRIGGER 2 (suffix 2) connector.

**Example:**       `" :BB:ARB:TRIG:SOUR EXT "`  
                      'selects an external trigger via the TRIGGER 1 connector

`" :BB:ARB:TRIG:DEL 200 "`  
                      'sets a delay of 200 samples for the trigger.

*RST value	Resolution	SCPI
0	1	Device-specific

**[SOURce<[1]|2>]:BB:ARB:TRIGger[:EXTernal<[1]|2>]:INHibit 0 ... 2<sup>32</sup>-1 samples**

The command specifies the number of samples by which a restart is to be inhibited following a trigger event. This command applies only in the case of external triggering. The numeric suffix to `EXTernal` distinguishes between the external trigger via the TRIGGER 1 (suffix 1) and TRIGGER 2 (suffix 2) connector.

**Example:**       `" :BB:ARB:TRIG:SOUR EXT "`  
                      'selects an external trigger via the TRIGGER 1 connector

`" :BB:ARB:TRIG:INH 200 "`  
                      'sets a restart inhibit for 200 samples following a trigger event.

*RST value	Resolution	SCPI
0	1	Device-specific

**[SOURce<[1]|2>]:BB:ARB:TRIGger:OBASband:DELay 0 ... 2^32-1 samples**

The command specifies the trigger delay (expressed as a number of samples) for triggering by the signal from the second path (two-path instruments only).

**Example:**       ":BB:ARB:TRIG:SOUR OBAS"  
                   'sets for path A the internal trigger executed by the signal from the second path (path B).  
                   ":BB:ARB:TRIG:DEL 200"  
                   'sets a delay of 200 samples for the trigger.

*RST value	Resolution	SCPI
0	1	Device-specific

**[SOURce<[1]|2>]:BB:ARB:TRIGger:OBASband:INHibit 0 ... 2^32-1 samples**

The command specifies the number of samples by which a restart is to be inhibited following a trigger event. This command applies only for triggering by the second path (two-path instruments only).

**Example:**       ":BB:ARB:TRIG:SOUR OBAS"  
                   'sets for path A the internal trigger executed by the signal from the second path (path B).  
                   ":BB:ARB:TRIG:INH 200"  
                   'sets a restart inhibit for 200 samples following a trigger event.

*RST value	Resolution	SCPI
0	1	Device-specific

**[SOURce<[1]|2>]:BB:ARB:TRIGger:OUTPut<[1]...4>:DELay 0 ... 2^20-1 Symbols**

The command defines the delay between the signal on the marker outputs and the start of the signals, expressed in terms of samples. Command :BB:ARB:TRIGger:OUTPut:DELay:FIXed ON can be used to restrict the range of values to the dynamic range, i.e. the range within which a delay of the marker signals can be set without restarting the marker and signal.

**Example:**       ":BB:ARB:TRIG:OUTP2:DEL 16"  
                   'sets a delay of 16 samples for the signal on connector MARKER 2.

*RST value	Resolution	SCPI
0 Symbols	1	Device-specific

**[SOURce<[1]|2>]:BB:ARB:TRIGger:OUTPut:DELay:FIXed ON | OFF**

The command restricts the marker delay setting range to the dynamic range. In this range the delay can be set without restarting the marker and signal. If a delay is entered in setting ON but is outside this range, the maximum possible delay is set and an error message is output.

The numeric suffix in OUTPut has no significance for this command, since the setting always affects every marker.

**Example:**       ":BB:ARB:TRIG:OUTP:DEL:FIX ON"  
                   'restricts the marker signal delay setting range to the dynamic range.

*RST value	Resolution	SCPI
OFF	-	Device-specific

**SOURce<[1]|2>:BB:ARB:TRIGger:OUTPut<[1]...4>:DELay:MAXimum**

The command queries the maximum marker delay for setting :BB:ARB:TRIGger:OUTPut:DELay:FIXed ON.

The command is a query only and therefore has no \*RST value.

**Example:** " :BB:ARB:TRIG:OUTP:DEL:FIX ON"  
 'restricts the marker signal delay setting range to the dynamic range.  
 " :BB:ARB:TRIG:OUTP:DEL:MAX"  
 'queries the maximum of the dynamic range.

Response: "2000"  
 'the maximum for the marker delay setting is 2000 samples.

*RST value	Resolution	SCPI
-	-	Device-specific

**[SOURce<[1]|2>:BB:ARB:TRIGger:OUTPut<[1]...4>:DELay:MINimum**

The command queries the minimum marker delay for setting :BB:ARB:TRIGger:OUTPut:DELay:FIXed ON.

The command is a query only and therefore has no \*RST value.

**Example:** " :BB:ARB:TRIG:OUTP:DEL:FIX ON"  
 'restricts the marker signal delay setting range to the dynamic range.  
 " :BB:ARB:TRIG:OUTP:DEL:MIN"  
 'queries the minimum of the dynamic range.

Response: "0"  
 'the minimum for the marker delay setting is 0 samples.

*RST value	Resolution	SCPI
-	-	Device-specific

**[SOURce<[1]|2>:BB:ARB:TRIGger:OUTPut<[1]...4>:MODE UNCHanged | REStart | PULSe | PATtern | RATio**

The command defines the signal for the selected marker output.

- Parameter: UNCHanged**  
 A marker signal as defined in the waveform file (tag 'marker mode x') is generated.
- REStart**  
 A marker signal is generated at every waveform start.
- PULSe**  
 A pulsed marker signal is generated. The pulse frequency (= symbol rate/divider) is defined with the SOUR:BB:ARB:TRIG:OUTP:PULS:DIV command and can be queried with the SOUR:BB:ARB:TRIG:OUTP:PULS:FREQ? command.
- PATtern**  
 A marker signal is generated with the aid of a user-definable bit pattern. The bit pattern is entered with the aid of command :BB:ARB:TRIGger:OUTPut:PATtern. The bit pattern is a maximum of 32 bits long.

**RATio**

A regular marker signal corresponding to the Time Off / Time On specifications in the commands :ARB:TRIGger:OUTPut:OFFTime and :ARB:TRIGger:OUTPut:ONTime is generated.

**Example:**     ":BB:ARB:TRIG:OUTP2:MODE PULS"  
                   'selects the pulsed marker signal on output MARKER 2.  
                   ":BB:ARB:TRIG:OUTP2:STAT ON"  
                   'activates the pulsed marker signal on output MARKER 2.

*RST value	Resolution	SCPI
REStart	-	Device-specific

**[SOURce<[1]|2>]:BB:ARB:TRIGger:OUTPut<[1]...4>:OFFTime 1 ... max. wavelength -1 sample**

The command sets the number of samples in a period (ON time + OFF time) during which the marker signal in setting :ARB:TRIGger:OUTPut:MODE RATio on the marker outputs is OFF.

**Example:**     ":BB:ARB:TRIG:OUTP2:OFFT 20"  
                   'sets an OFF time of 20 samples for marker signal 2 (in case of two-path instruments, on path A).

*RST value	Resolution	SCPI
1	1	Device-specific

**[SOURce<[1]|2>]:BB:ARB:TRIGger:OUTPut<[1]...4>:ONTime 1 ... max. wavelength -1 sample**

The command sets the number of samples in a period (ON time + OFF time) during which the marker signal in setting :ARB:TRIGger:OUTPut:MODE RATio on the marker outputs is ON.

**Example:**     ":BB:ARB:TRIG:OUTP2:ONT 20"  
                   'sets an ON time of 20 samples for marker 2 (in case of two-path instruments, on path A).

*RST value	Resolution	SCPI
1	1	Device-specific

**[SOURce<[1]|2>]:BB:ARB:TRIGger:OUTPut<[1]...4>:PATTern #B0,1 ... #B111...1,32**

The command defines the bit pattern used to generate the marker signal in the setting SOURce:BB:ARB:TRIGger:OUTPut:MODE PATTern 0 is marker off, 1 is marker on.

**Example:**     ":BB:ARB:TRIG:OUTP2:PATT #H39FE0000,32"  
                   'sets a bit pattern.  
                   ":BB:ARB:TRIG:OUTP2:MODE PATT"  
                   'activates the marker signal according to a bit pattern on output MARKER 2.

*RST value	Resolution	SCPI
0	-	Device-specific

**[SOURce<[1]|2>]:BB:ARB:TRIGger:OUTPut<[1]...4>:PULSe:DIVider 2 ... 2<sup>10</sup>**

The command sets the divider for the pulsed marker signal in the setting SOURce:BB:ARB:TRIGger:OUTPut:MODE PULSe. The pulse frequency is derived by dividing the symbol rate by the divider.

**Example:**       ":BB:ARB:TRIG:OUTP2:PULS:DIV 2"  
                  'sets the divider for the marker signal on output MARKER 2 to the value 2.  
                  ":BB:ARB:TRIG:OUTP2:FREQ?"  
                  'queries the resulting pulse frequency of the marker signal  
  
Response: "66 000"  
                  'the resulting pulse frequency is 66 kHz.

*RST value	Resolution	SCPI
2	1	Device-specific

**[SOURce<[1]|2>]:BB:ARB:TRIGger:OUTPut<[1]...4>:PULSe:FREQuency?**

The command queries the pulse frequency of the pulsed marker signal in the setting SOURce:BB:ARB:TRIGger:OUTPut:MODE PULSe. The pulse frequency is derived by dividing the symbol rate by the divider. The divider is defined with command :BB:ARB:TRIG:OUTP:PULS:DIV.

The command is a query only and therefore has no \*RST value.

**Example:**       ":BB:ARB:TRIG:OUTP2:PULS:DIV 4"  
                  'sets the divider for the marker signal on output MARKER 2 to the value 4.  
                  ":BB:ARB:TRIG:OUTP2:MODE PULS"  
                  'enables the pulsed marker signal.  
                  ":BB:ARB:TRIG:OUTP2:PULS:FREQ?"  
                  'queries the pulse frequency of the marker signal.  
  
Response: "33 000"  
                  'the resulting pulse frequency is 33 kHz.

*RST value	Resolution	SCPI
-	-	Device-specific

**[SOURce<[1]|2>]:BB:ARB:TRIGger:RMODE**

The command queries the status of waveform output or all trigger modes with ARB on. The command is a query command and therefore has no \*RST value.

**Parameter:**     **RUN**  
                  The waveform is output. A trigger event occurred in the triggered mode.  
  
                  **STOP**  
                  the waveform is not output. A trigger event did not occur in the triggered modes, or waveform output was stopped by the command :BB:ARB:TRIG:ARM:EXECute (armed trigger modes only).

**Example:** "SOUR:BB:ARB:TRIG:SOUR EXT"  
 'sets external triggering via the TRIGGER 1 connector.  
 "SOUR:BB:ARB:TRIG:MODE ARET"  
 'selects the Armed\_Retrigger mode.  
 "SOUR:BB:ARB:TRIG:RMOD?"  
 'queries the current status of waveform output.  
 Response: "RUN"  
 'the waveform is output, an external trigger was executed.

*RST value	Resolution	SCPI
-	-	Device-specific

**[SOURce<[1]|2>]:BB:ARB:TRIGger:SLENgth 1 ... (2^32-1) Samples**

The command defines the length of the signal sequence to be output in the **Single** trigger mode. The unit is defined with command SOUR:BB:ARB:TRIG:SLUNit. It is possible to output deliberately just part of the waveform, an exact sequence of the waveform, or a defined number of repetitions of the waveform.

**Example:** "SOUR:BB:ARB:SEQ SING"  
 'sets trigger mode Single.  
 "SOUR:BB:ARB:TRIG:SLUN SAMP"  
 'sets unit Samples for the entry of sequence length.  
 "SOUR:BB:ARB:TRIG:SLEN 200"  
 'sets a sequence length of 200 samples. The first 200 samples of the current waveform will be output after the next trigger event.

*RST value	Resolution	SCPI
1 Waveform length	-	Device-specific

**[SOURce<[1]|2>]:BB:ARB:TRIGger:SLUNit SAMPlE | SEQUence**

The command defines the unit for the entry of the length of the signal sequence (SOUR:BB:ARB:TRIG:SLEN) to be output in the **Single** trigger mode (SOUR:BB:ARB:SEQ SING).

**Example:** "SOUR:BB:ARB:SEQ SING"  
 'sets trigger mode Single.  
 "SOUR:BB:ARB:TRIG:SLUN SEQ"  
 'sets unit Sequence length for the entry of sequence length.  
 "SOUR:BB:ARB:TRIG:SLEN 2"  
 'sets a sequence length of 2 waveforms. The current waveforms will be output twice after the next trigger event.

*RST value	Resolution	SCPI
SEQUence	-	Device-specific

**[SOURce<[1]|2>]:BB:ARB:TRIGger:SMODE** SAME | NEXT | NSEam

The command selects the extended trigger mode for multi segment waveforms.

**Parameter:** **SAME**

The currently selected segment is output repeatedly.

**NEXT**

The current segment ceases to be output as soon as a new segment is entered with command :BB:ARB:WSEG:NEXT and the new segment starts to be output after a system-imposed signal gap.

**NSEam**

The segment selected with command :BB:ARB:WSEG:NEXT is not output until the whole of the current segment has been output (wrap around). In this case the signal transition is seamless.

**Example:** "SOUR2:BB:ARB:SEQ AUTO"  
'selects trigger mode AUTO.

"SOUR2:BB:ARB:TRIG:SMOD SAME"  
'the same segment of the waveform is output repeatedly.

*RST value	Resolution	SCPI
NEXT	-	Device-specific

**[SOURce<[1]|2>]:BB:ARB:TRIGger:SOURce** INTernal | EXTernal | BEXTernal | OBASeband

The command selects the trigger source.

**Parameter:** **INTernal**

Triggering is executed by means of the Trigger command in the case of remote control, and by means of **Execute Trigger** in the case of manual operation.

**EXTernal**

Triggering is executed by means of the signal on the TRIGGER 1 connector.

**BEXTernal**

Triggering is executed by means of the signal on the TRIGGER 2 connector.

**OBASeband**

Triggering is executed by means of the signal from the second path (two-path instruments only).

**Example:** ":BB:ARB:TRIG:SOUR INT"  
'sets internal triggering.

*RST value	Resolution	SCPI
INTernal	-	Device-specific

**[SOURce<[1]|2>]:BB:ARB:TSIGnal:SINE:CREate:NAMed** <file name>

Generates a signal and saves it to a waveform file.

The command does not allow a query.

**Example:** ":BB:ARB:TSIG:SINE:CRE:NAM 'sine\_test'"  
'generates a test sine signal and saves it into the wavfile sine\_test.

*RST value	Resolution	SCPI
-	-	Instrument-specific

**[SOURCE<[1]>]:BB:ARB:TSIGnal:SINE:CREate**

Generates a signal and uses it as output straight away.  
 The command does not allow a query.

**Example:**           ":BB:ARB:TSIG:SINE:CRE"  
                           'generates a test sine signal and uses it as output straight away.

*RST value	Resolution	SCPI
-	-	Instrument-specific

**[SOURCE<[1]>]:BB:ARB:TSIGnal:SINE:FREQuency 100 Hz ... 25 MHz**

The command sets the frequency of the simple sinusoidal test signal. This signal is used as output via the I channel. A sine wave of the same frequency but optionally phase-shifted is generated on the Q path (ARB:TSIGnal:SINE:POFFset).

**Example:**           ":BB:ARB:TSIG:SINE:FREQ 100 kHz"  
                           'sets a sine signal of 100 kHz.

*RST value	Resolution	SCPI
1 kHz	0.01 Hz	Instrument-specific

**[SOURCE<[1]>]:BB:ARB:TSIGnal:SINE:PHASe -180.00 Deg ... + 180.00 Deg**

The command sets the phase offset of the sine wave on the Q channel relative to the sine wave on the I channel.

**Example:**           ":BB:ARB:TSIG:SINE:PHAS 90"  
                           'sets a phase offset of 90 degrees.

*RST value	Resolution	SCPI
90 DEG	0.01 DEG	Instrument-specific

**[SOURCE<[1]>]:BB:ARB:TSIGnal:SINE:SAMPles 3 ... 1000 samples per period**

The command sets the sample rate for the sine signal in samples per period. The resulting clock rate must not exceed the maximum ARB clock rate of 100 MHz. The maximum value is automatically restricted by reference to the set frequency.

**Example:**           ":BB:ARB:TSIG:SINE:SAMP 100"  
                           'sets a sample rate of 100 samples per period.

*RST value	Resolution	Dependency	SCPI
100 samples per period	1	ARB:SIGN:SAMP MAX is automatically restricted by frequency x samples <= 100 MHz	Instrument-specific



**[SOURce<[1]|2>]:BB:ARB:WAVeform:CATalog? <path>**

This command reads out the files in the default directory. The default directory is set using command `MMEM:CDIRectory`. When the names of the waveform files are returned they are separated by commas. Only files with the file extension `*.wv` will be listed.

The command is a query command and therefore has no `*RST` value.

**Example:** `MMEM:CDIR 'D:\user\waveform'`  
 'sets the default directory to D:\user\waveform.'  
`":BB:ARB:WAV:CAT?"`  
 'reads out all the files in the default directory.'  
 Response: `"sin1, wave"`  
 'the directory D:\user\waveform contains the waveform files 'sin1.wv' and 'wave.wv'.'

*RST value	Resolution	SCPI
-	-	Device-specific

**[SOURce<[1]|2>]:BB:ARB:WAVeform:CATalog:LENGth? <path>**

This command reads out the number of files in the default directory for waveform files (D:\Lists\ARBWave). Only files with the file extension `*.wv` will be listed.

The command is a query command and therefore has no `*RST` value.

**Example:** `MMEM:CDIR 'D:\user\waveforms'`  
 'sets the default waveform directory.'  
`BB:ARB:WAV:CAT:LENG?"`  
 'reads out the number of files in the default waveform directory.'  
 Response: `"1"`  
 'there is 1 file in the default waveform directory.'

*RST value	Resolution	SCPI
-	-	Device-specific

**[SOURce<[1]|2>]:BB:ARB:WAVeform:DATA <waveform filename>[,<binary data block>]**

This command writes the block data `<binary data block>` to the file identified by `<file_name>`. The IEC bus delimiter should be set to EOI when this is done, in order to ensure trouble-free data transmission.

The complete content of the waveform file is transmitted as binary data block.

The associated query command transmits the specified file from the R&S Signal Generator to the control computer via the IEC bus. Please note that the buffer on the control computer must be big enough to accept the file. The setting for the IEC bus delimiter is of no significance.

Using this command, waveforms can be read out directly from or sent directly to the instrument.

The structure of the binary data block is as follows: `#234<binarydata block>`

# is always used to introduce the binary block  
 <number> states how many places in the following length data (in the example 2)  
 <number> defines the number of following bytes (in the example 34)  
 <binary data block> binary block data of the specified length.

Only the file name has to be entered, the file extension may be omitted. Waveform data is stored only in files with the specific file extensions \*.wv. The default directory is set using command MMEM:CDIRectory. A path can also be specified, in which case the files in the specified directory are read.

**Example:**       ":BB:ARB:WAV:DATA 'd:\user\TEST1.WV',#3767<bin data block>"  
                  'writes the block data to file 'test1.wv' in the d:\user directory.

                  ":BB:ARB:WAV:DATA? 'd:\user\TEST1.WV'"  
                  'sends the data from file 'Test1.wv' in the d:\user directory from the R&S Signal Generator to the control computer in the form of a binary block.

*RST value	Resolution	SCPI
-	-	Device-specific

**[SOURce<[1]>]:BB:ARB:WAVeform:DATA? <filename>,<tag>**

The command queries the content of the specified tag of the selected Waveform file (see following section "R&S Signal Generator Waveform and List Format"). The default directory is set using command MMEM:CDIRectory. A path can also be specified, in which case the files in the specified directory are read.

The command is a query command and therefore has no \*RST value.

**Parameter:**       'comment' | 'copyright' | 'date' | 'lacfiter' | 'marker name' | 'poweroffset'

**Example:**       BB:ARB:WAV:SEL 'D:\user\wave1.wv'  
                  BB:ARB:WAV:TAG? 'comment'  
                  'queries the content of the 'comment' tag of file wave1.wv in the D:\user directory.

                  Response: "Sine wave for test purposes"

*RST value	Resolution	SCPI
-	-	Device-specific

**[SOURce<[1]>]:BB:ARB:WAVeform:DELeTe <waveform filename>**

The command deletes the specified waveform file. If the file is not on the default path, the path must be specified at the same time. The file extension may be omitted. Only files with the file extension \*.wv will be deleted.

**Example:**       ":BB:ARB:WAV:DEL 'D:\user\wave1.wv'"  
                  'deletes waveform file 'wave1.wv' from the D:/user directory.

*RST value	Resolution	SCPI
-	-	Device-specific

**[SOURce<[1]|2>]:BB:ARB:WAVeform:FREE?**

The command queries the free disk space on the default path of the R&S Signal Generator harddisk.

The command is a query command and therefore has no \*RST value.

**Example:** "MMEM:CDIR 'D:\user\waveform"  
 'sets the default directory to D:\user\waveform.  
 ":BB:ARB:WAV:FREE?"  
 'queries the free disk space in directory D:\user\waveform.

*RST value	Resolution	SCPI
-	-	Device-specific

**[SOURce<[1]|2>]:BB:ARB:WAVeform:POINts? <waveform filename>**

The command queries the number of samples in the waveform file selected using command :ARB:WAV:SEL. Only the file name has to be entered. Only files with the file extension \*.wv will be read out.

The command is a query command and therefore has no \*RST value.

**Example:** ":BB:ARB:WAV:POINt?"  
 'queries the number of I/Q values pairs in the waveform file.  
 Response: "401"  
 'the waveform file contains 401 I/Q values pairs.

*RST value	Resolution	SCPI
-	-	Device-specific

**[SOURce<[1]|2>]:BB:ARB:WAVeform:SElect <waveform filename>**

The command selects the waveform file. If the file is not on the default path, the path must be specified at the same time. If no file of the specified name exists, it is created. The file extension may be omitted. Only files with the file extension \*.wv will be created or loaded.

**Example:** ":BB:ARB:WAV:SEL 'D:\user\wave1.wv'"  
 'selects waveform file 'wave1.wv' from the D:/user directory and loads it.  
 ":BB:ARB:TRIG:SEQ AAUT"  
 'sets trigger mode Armed\_Auto.  
 ":BB:ARB:TRIG:SOUR INT"  
 'selects internal triggering.  
 ":BB:ARB:STAT ON"  
 'switches on the ARB generator.  
 ":BB:ARB:TRIG:EXEC"  
 'starts generating the selected waveform.

*RST value	Resolution	SCPI
-	-	Device-specific

**[SOURce<[1]|2>]:BB:ARB:WAVEform:TAG? <tag name>**

The command queries the content of the specified tag of the selected Waveform file (see following section "R&S Signal Generator Waveform and List Format").

The command is a query command and therefore has no \*RST value.

**Example:**           ":BB:ARB:WAV:TAG? 'comment'"  
                          'queries the content of the 'comment' tag.

Response: "Sine wave for test purposes"

*RST value	Resolution	SCPI
-	-	Device-specific

**[SOURce<[1]|2>]:BB:ARB:WSEGment?**

This command queries the currently output segment of the multi segment waveform.

The command is a query command and therefore has no \*RST value.

**Example:**           ":BB:ARB:WSEG?"  
                          'queries the currently output segment.

Response "2"  
                          'segment 2 is currently output.

*RST value	Resolution	SCPI
-	-	Device-specific

**[SOURce<[1]|2>]:BB:ARB:WSEGment:CLOad <configuration file\_name>**

This command creates a multi segment waveform using the current entries of the specified configuration file.

This multi segment waveform is saved with the file name specified in the configuration file . The file extension is \*. **wv**. Digital standard **ARB** is activated, the new multi segment waveform is loaded and the first segment is output in accordance to the trigger settings.

This command triggers an event and therefore has no \*RST value and no query form.

**Example:**           "MMEM:CDIR 'D:\user\waveform'"  
                          'sets the default directory to D:\user\waveform.

                      ":BB:ARB:WSEG:CONF:SEL 'multi\_sin'"  
                          'creates the configuration file multi\_sin.inf\_mswv in the default directory.

                      ":BB:ARB:WSEG:CONF:SEGM:APP 'sinus1'"  
                          'includes waveform sinus1.wv as segment 1 in the configuration file. The waveform must be available in the default directory.

                      ":BB:ARB:WSEG:CONF:SEGM:APP 'sinus2'"  
                          'includes waveform sinus1.wv as segment 2 in the configuration file. The waveform must be available in the default directory.

                      ":BB:ARB:WSEG:CONF:OFIL 'mseg1\_2'"  
                          'defines the file name mseg1\_2.wv for the multi segment waveform.

                      ":BB:ARB:WSEG:CLO 'multi\_sin'"  
                          'creates multi segment waveform mseg1\_2.wv using the settings of the configuration file multi\_sin.inf\_mswv.  
                          The new multi segment waveform is loaded and digital standard **ARB** is activated.

*RST value	Dependencies	SCPI
-	SOUR:BB:ARB:WAV:SEL = <new Waveform> SOUR:BB:ARB:STATe = ON	device-specific

**[SOURce<[1]|2>]:BB:ARB:WSEgment:CONFigure:CATalog?**

This command queries the available configuration files in the specified default directory. The configuration files are used to create multi segment waveform files..

The command is a query command and therefore has no \*RST value.

**Example:** "MMEM:CDIR 'D:\user\waveform"  
'sets the default directory to D:\user\waveform.  
":BB:ARB:WSEG:CONF:CAT?"  
'reads out all the configuration files in the default directory.  
Response: "mult1, multi2"  
'the directory D:\user\waveform contains the configuration files  
'mult1.inf\_mswv' and 'multi2.inf\_mswv'.

*RST value	Resolution	SCPI
-	-	device-specific

**[SOURce<[1]|2>]:BB:ARB:WSEgment:CONFigure:CLOCK max sample rate .. 100MHz**

This command defines the clock rate used for multi segment waveform output in case of Clock Mode **User** (:BB:ARB:WSEG:CONF:CLOCK:MODE USER).

**Example:** ":BB:ARB:WSEG:CONF:CLOC:MODE USER"  
'selects Clock Mode User.  
":BB:ARB:WSEG:CONF:CLOC 50MHz"  
'defines a clock rate of 50 MHz.

*RST value	Resolution	SCPI
Max. Sample Rate	0.001 Hz	device-specific

**[SOURce<[1]|2>]:BB:ARB:WSEgment:CONFigure:CLOCK:MODE UNCHanged | HIGHest | USER**

This command selects the clock rate mode for the multi segment waveform.

**Parameter: UNCHanged**  
The segments are output with the clock rate defined in the waveform file. Extended Trigger Mode **Next Segment Seamless** (:BB:ARB:TRIG:SMOD NSEam) can only be selected if all segments have the same clock rate. Extended Trigger Mode **Next Segment** (:BB:ARB:TRIG:SMOD NEXT) can only be selected if trigger mode **Internal** is selected.(:BB:ARB:TRIG:SOUR INT).

**HIGHest**  
The segments are output at the highest available clock rate.

**USER**  
The segments are output with the clock rate defined with command :BB:ARB:WSEG:CONF:CLOC.

**Example:**       ":BB:ARB:WSEG:CONF:CLOC:MODE UNCH"  
                   'selects clock mode unchanged. The segments are output with the clock rate defined in the waveform file.

*RST value	Resolution	SCPI
UNCHanged	-	device-specific

**[SOURce<[1]|2>]:BB:ARB:WSEGment:CONFigure:COMMent <string>**

This command enters a comment for the configuration file. The configuration file must be specified with command :BB:ARB:WSEG:CONF:SEL.

**Example:**       ":BB:ARB:WSEG:CONF:COMM <3gpp\_up>"  
                   'enters comment "3gpp\_up".

*RST value	Resolution	SCPI
-	-	device-specific

**[SOURce<[1]|2>]:BB:ARB:WSEGment:CONFigure:DELete**

This command deletes the configuration file. The configuration files are used to create multi segment waveform files.

This command triggers an event and therefore has no \*RST value and no query form.

**Example:**       "MMEM:CDIR 'D:\user\waveform"  
                   'sets the default directory to D:\user\waveform.  
                   ":BB:ARB:WSEG:CONF:DEL 'multil'"  
                   'deletes configuration file multil.inf\_mswv.

*RST value	Resolution	SCPI
-	-	device-specific

**[SOURce<[1]|2>]:BB:ARB:WSEGment:CONFigure:LEVel[:MODE] UNCHanged | ERMS**

This command selects the level mode for the multi segment waveform.

**Parameter:       UNCHanged**  
                   The segments are output exactly as defined in the files.

**ERMS**  
                   The segments are output so that all segments have the same rms value.

**Example:**       ":BB:ARB:WSEG:CONF:LEV:MODE UNCH"  
                   'selects level mode unchanged. The segments are output as defined in the waveform file.

*RST value	Resolution	SCPI
UNCHanged	-	device-specific

**[SOURce<[1]>]:BB:ARB:WSEgment:CONFigure:OFILe <file\_name>**

This command defines the file name for the multi segment waveform. This file name is stored in the configuration file and is used when a waveform is created (command :BB:ARB:WSEG:CLoad or :BB:ARB:WSEG:CREate). The file extension is \*.wv.

This command triggers an event and therefore has no \*RST value and no query form.

**Example:** "MMEM:CDIR 'D:\user\waveform"  
 'sets the default directory to D:\user\waveform.  
 ":BB:ARB:WSEG:CONF:SEL 'multi1'"  
 'creates the configuration file multi1.inf\_mswv in default directory.  
 ":BB:ARB:WSEG:CONF:OFIL 'mseg1\_2'"  
 'defines the file name mseg1\_2.wv for the multi segment waveform file created using configuration file multi1.inf\_mswv.

*RST value	Resolution	SCPI
-	-	device-specific

**[SOURce<[1]>]:BB:ARB:WSEgment:CONFigure:SEGMENT:APPend <file\_name>**

This command appends the specified waveform to the configuration file.

This command triggers an event and therefore has no \*RST value and no query form.

**Example:** "MMEM:CDIR 'D:\user\waveform"  
 'sets the default directory to D:\user\waveform.  
 ":BB:ARB:WSEG:CONF:SEL 'new'"  
 'creates the configuration file new.inf\_mswv in the default directory.  
 ":BB:ARB:WSEG:CONF:SEGM:APP 'arb1'"  
 'appends waveform arb1.wv to configuration file new. Waveform arb1 will be the first segment of a multi segment waveform created with configuration file new.

*RST value	Resolution	SCPI
-	-	device-specific

**[SOURce<[1]>]:BB:ARB:WSEgment:CONFigure:SEGMENT:CATalog?**

This command queries the segments of the currently selected configuration file.

The command is a query command and therefore has no \*RST value.

**Example:** "MMEM:CDIR 'D:\user\waveform"  
 'sets the default directory to D:\user\waveform.  
 ":BB:ARB:WSEG:CONF:SEL 'multi\_sin'"  
 'selects the configuration file multi\_sin.inf\_mswv.  
 ":BB:ARB:WSEG:CONF:SEGM:CAT?"  
 'queries the segments of the selected configuration file.  
 Response: "arb4, arb2"  
 'The configuration file includes the segments 'arb4.wv' and 'arb2.wv'.

*RST value	Resolution	SCPI
-	-	device-specific

**[SOURCE<[1]>]:BB:ARB:WSEGment:CONFigure:SElect <file\_name>**

The command selects the configuration file in the default directory. A path can also be specified, in which case the files in the specified directory are selected. If a configuration file with the specified name does not yet exist, it is created. The file extension may be omitted. Only files with the file extension **\*.inf\_mswv** will be selected or created.

**Example:** "MMEM:CDIR 'D:\user\waveform"  
 'sets the default directory to D:\user\waveform.  
 ":BB:ARB:WSEG:CONF:SEL 'new'"  
 'create configuration file new.inf\_mswv in the default directory.

*RST value	Resolution	SCPI
-	-	device-specific

**[SOURCE<[1]>]:BB:ARB:WSEGment:CREate <file\_name>**

This command creates a multi segment waveform using the current settings of the specified configuration file. The multi segment waveform is saved into the file defined in the configuration file. The file extension is **\*.wv**.

This command triggers an event and therefore has no **\*RST** value and no query form.

**Example:** "MMEM:CDIR 'D:\user\waveform"  
 'sets the default directory to D:\user\waveform.  
 ":BB:ARB:WSEG:CONF:SEL 'new'"  
 'creates the configuration file new.inf\_mswv in the default directory.  
 ":BB:ARB:WSEG:CONF:SEGM:APP 'arb1.wv'"  
 "includes waveform arb1.wv as segment 1 in the configuration file. The waveform must be available in the default directory.  
 ":BB:ARB:WSEG:CONF:OFIL 'multi\_wv1'"  
 'defines the file name multi\_wv1.wv for the multi segment waveform.  
 ":BB:ARB:WSEG:CRE 'new'"  
 'creates multi segment waveform multi\_wv1.wv using the settings of the configuration file new.inf\_mswv.

*RST value	Resolution	SCPI
-	-	device-specific



[SOURce<[1]>]:BB:ARB:WSEGment:NEXT 0 ... 2000

This command selects the segment to be output.

**Example:**

```
"MMEM:CDIR 'D:\user\waveform"
'sets the default directory to D:\user\waveform.

":BB:ARB:WSEG:NEXT 2"
'selects segment 2 to be output.

":BB:ARB:TRIG:SMOD NEXT"
'selects extended trigger mode next, i.e. the segment specified with command
:BB:ARB:WSEG:NEXT will be output.

":BB:ARB:SEQ AUTO"
'selects trigger mode Auto.

":BB:ARB:WAV:SEL 'multi_wv1'"
'loads multi segment waveform multi_wv1.wv. Generation of segment 2
starts.

":BB:ARB:WSEG:NEXT 3"
'switched at once to output of segment 3.
```

RST value	Resolution	SCPI
0	-	device-specific

## R&S Signal Generator Waveform and List Format

The R&S Signal Generator uses a tag-oriented format for externally or internally generated waveforms as well as for data and control lists. The data can be transmitted via the IEC bus from an external computer to the R&S Signal Generator and vice versa. For these purposes the file is transmitted as a binary data block, using IEC bus command `SOUR:BB:ARB:WAV:DATA`.

---

**Note:**

*A waveform version number is not necessary due to the flexible, tag-based form.*

---

Tags are self-contained information units. Their general format is:

**{Name: Data} or {Name-Length: Data}**

The colon separates the name part and the data part. The colon can be followed by a space for the sake of legibility.

The **Name** identifies the tag. It is always expressed in capital letters.

The **Data** is tag-specific, and in most cases it is in ASCII plain text.

The **Length** specifies the number of bytes in a WAVEFORM tag or DATA LIST tag (from ':' to '"', ASCII integer)

Each waveform file must begin with the TYPE tag. The sequence of the remaining tags is arbitrary. For each tag an indication shows whether it *must* be included in the file concerned (mandatory) or *may* be included (optional).

Unknown tags are not analyzed by the R&S Signal Generator. On the other hand they are left unchanged, are saved without an error message and can be read back again.

R&S AMIQ waveforms can also be loaded on the R&S Signal Generator, where they are converted internally into an R&S Signal Generator waveform.

The following sections first describe the mandatory TYPE tag which identifies the file and is always located at the start of the file. The rest of the tags used in the R&S Signal Generator are then described in alphabetical order. Most tags are valid for all three file types. If a tag is valid only for a single file type, e.g. only for a waveform, this fact is indicated in the description.

---

**{TYPE: magic, xxxxxxxx} (mandatory, must be the first tag in the file)**

The *TYPE* tag identifies the file as a valid R&S Signal Generator file. It must be present and must be the first in the waveform. If a file of the same name already exists on the target medium, it is overwritten.

---

**Note:**

*AMIQ waveforms can also be loaded on the R&S Signal Generator, where they are converted internally into an R&S Signal Generator waveform.*

---

<b>magic</b>	'magic' designates the file type and has the following values:
<b>SMU-WV</b>	The file contains a valid R&S Signal Generator waveform.
<b>SMU-DL</b>	The file contains a valid R&S Signal Generator data list.
<b>SMU-CL</b>	The file contains a valid R&S Signal Generator control list.

**xxxxxxx:** 'xxxxxxx' is an ASCII-coded checksum of the data part of the WAVEFORM tag in the file. This value is always 0 for data lists and control lists.

The checksum for waveforms is used for detecting transmission errors. If the *TYPE* tag contains 0 or a non-numeric value for the checksum, it is ignored.

It is calculated in accordance with the following algorithm, where 'start' is a pointer to the first byte after the '#' character in the WAVEFORM tag and 'length' is the number of bytes between 'start' and the closing curly bracket (excluding the latter; 'length' must be divisible by 4 without a remainder):

```

UINT32 checksum(void *start, UINT32 length)
{
    UINT32 i, result = 0xA50F74FF;

    for(i=0; i < length/4; i++)
        result = result ^ ((UINT32 *)start)[i];

    return(result);
}

```

**Example:** {TYPE: SMU-WV,106656}

**IEC bus query:** ":BB:ARB:WAV:TAG? 'TYPE'"  
'queries the content of the 'TYPE' tag.

Response: "'SMU-WV,106656'"  
'this is a valid waveform.

#### **{CLOCK: frequency} (mandatory for waveforms)**

The tag specifies the clock frequency at which the waveform has to be output, in Hz. A query of *ARB:CLOCK?* after loading the waveform returns the value set using the *CLOCK* tag. This value can subsequently be altered with the aid of the *ARB:CLOCK* command.

**Example:** {CLOCK: 54000000}

**IEC bus query:** ":BB:ARB:WAV:TAG? 'CLOCK'"  
'queries the content of the 'CLOCK' tag.

Response: "54000000"  
'the clock frequency is set to 54 MHz.

#### **{COMMENT: string} (optional)**

The tag contains a plain text ASCII string of arbitrary length. The string is not analyzed in the R&S Signal Generator. It is used to describe the file. The string is allowed to contain all printable ASCII characters except the closing curly bracket.

**Example:** {COMMENT: File with data for 3GPP enhanced channels}

**IEC bus query:** ":BB:ARB:WAV:TAG? 'COMMENT'"  
'queries the content of the 'COMMENT' tag of the selected waveform file.

Response: "File with data for 3GPP enhanced channels"  
'the comment on the waveform reads "File with data for 3GPP enhanced channels".'

**{COPYRIGHT: string} (optional for waveforms)**

The tag contains an ASCII string of arbitrary length. The string is not analyzed in the R&S Signal Generator. It is used to store copyright information about the file content.

**Example:** {COPYRIGHT: Rohde&Schwarz}

**IEC bus query:** ":BB:ARB:WAV:TAG? 'COPYRIGHT'"  
'queries the content of the 'COPYRIGHT' tag of the selected waveform file.

**Response:** "'Rohde&Schwarz'"  
'copyright resides with Rohde&Schwarz.'

**{DATA BITLENGTH: BitLength} (mandatory for data lists)**

The tag contains the length of the data held in the "DATA LIST" tag in bits in ASCII format.

**Example:** {DATA BITLENGTH: 444}

**IEC bus query:** ":BB:DM:DLIS:TAG? 'DATA BITLENGTH'"  
'queries the content of the 'DATA BITLENGTH' tag of the selected data list file.

**Response:** "'444'"  
'the data list is 444 bits long.'

**{DATA LIST-Length: #d<sub>0</sub>d<sub>1</sub>...d<sub>x</sub>...d<sub>N-1</sub>...} (mandatory for data lists)**

The tag contains the actual bit sequence of the data list in binary format.

**Length** 'Length' defines the number of bytes in the DATA LIST tag in ASCII Format (for format see WAVEFORM length).

**d<sub>x</sub>** Data bits in binary format (8-bit unsigned characters, MSB first).

**Example:** {DATA LIST-56: #0111000010101010100101010100.....001010}

**Example:** ":BB:DM:DLIS:TAG? 'DATA LIST'"  
'queries the content of the 'DATA LIST' tag of the selected data list file.

**Response:** "56"  
'transmits a data list which is 56 bytes long from ':' to ')'

**{DATE: yyyy-mm-dd;hh:mm:ss} (optional)**

The tag contains the date and time at which the file was created. The year must be expressed as four digits. The R&S Signal Generator does not analyze this tag.

**Example:** {DATE: 2003-04-02;14:32:12}

**IEC bus query:** ":BB:ARB:WAV:TAG? 'DATE'"  
'queries the content of the 'DATE' tag of the selected waveform file.

**Response:** "'2003-04-02;14:32:12'"  
'the waveform was created on April 2, 2003 at 14 hrs 32 min.'

**{CONTROL LENGTH: ControlLength} (optional)**

The tag contains the length of the control list in ASCII format. If this tag is not used, the control list length is determined by the highest position used in one of the LIST tags. It is recommended to set this value to be equal to the number of samples in order to keep marker signals and wave data synchronized.

**Example:** {CONTROL LENGTH: 444}

**IEC bus query:** ":BB:ARB:WAV:TAG? 'CONTROL LENGTH'"  
'queries the length of the control list.

Response: "'444'"

**{LEVEL OFFS: RMSOffset\_dB,PeakOffset\_dB} (optional for waveforms)**

The tag determines the level of the ARB signal in the waveform file. The offset levels define the offset of rms and peak value relative to the 16-bit full scale modulation ( $-32767$  to  $+32767$ ) = 0 dB.

**RMSOffset\_dB** 'RMSOffset\_dB' defines the rms level offset of the signal relative to full scale ARB signal in the "WAVEFORM" tag. The offset is defined in ASCII float format. The value is always positive. A 3dB value indicates that the rms level of the signal is 3 dBs below the full scale (full scale = max. amplitude of vector of I/Q samples =  $|SIQ|_{max} = \sqrt{(I^2+Q^2)_{max}} = 0$  dB)

**PeakOffset\_dB** 'PeakOffset\_dB' defines the peak level offset of the signal relative to full scale for the ARB signal in the "WAVEFORM" tag. The offset is defined in ASCII float format. The value usually equals 0 dB as in the majority of cases the I/Q samples (signed 16-bit integer values) are modulated to full scale: Full scale = 0 dB = max. amplitude of vector of I/Q samples =  $|SIQ|_{max} = \sqrt{(I^2+Q^2)_{max}} = (2^{15})-1 = 32767$ .

A positive PeakOffset\_dB value indicates that a headroom to full scale is provided when generating the waveform. A negative PeakOffset\_dB value indicates that overrange is likely for some samples, i.e. clipping might occur.

The crest factor can be calculated from the two values as follows:

crest factor =  $|PeakOffset\_dB - RMSOffset\_dB|$

**Example:** {LEVEL OFFS: 3.45,2}

**IEC bus query:** ":BB:ARB:WAV:TAG? 'LEVEL OFFS'"  
'queries the content of the 'LEVEL OFFS' tag of the selected waveform file.

Response: "'3.45,2'"

'the level of the waveform is below full scale, clipping will not occur.'

**{SAMPLES: Samples} (optional for waveforms)**

The tag contains the number of I/Q samples in the waveform in ASCII format.

**Example:** {SAMPLES: 4333}

**IEC bus query:** ":BB:ARB:WAV:TAG? 'SAMPLES'"  
'queries the content of the 'SAMPLES' tag of the selected waveform file.

Response: "'4333'"

'the waveform contains 4333 I/Q samples.'

**{[TRACE] LIST [#]: Pos<sub>0</sub>:Val<sub>0</sub>;Pos<sub>1</sub>:Val<sub>1</sub>;...Pos<sub>x</sub>:Val<sub>x</sub>;...Pos<sub>N-1</sub>:Val<sub>N-1</sub>}**  
**mandatory for control lists / optional for waveforms)**

The tag contains the data for the marker and control signals in the control list or the marker signals of ARB waveforms. To select which of these signals is defined, [TRACE] and the associated number are used. For ARB waveforms it is only meaningful to define marker signals.

**[TRACE]** [TRACE] specifies the name of the marker or control signal: You may choose from the following names: MARKER; BURST; LEVATT; CW MODE; HOP

**[#]** [#] specifies the number in the case of control signals and marker signals with the same name. There is a choice between 4 markers and 3 LEVATT signals. Lines LEVATT 1 and 2 are needed for internal purposes and should not be used.

**Pos** Pos specifies in ASCII format the number of the position in the sequence, with effect from which the binary state of the marker or of the control signal changes from 0 to 1 or from 1 to 0.

**Val** Val specifies the binary state of the marker or of the control signal{0; 1} from Pos<sub>x</sub> to Pos<sub>x+1</sub> exclusive in ASCII format.

**Example:** {MARKER LIST 1: 0:0;10:1;20:0;30:1}

**IEC bus query:** ":BB:DM:CLIS:TAG? 'MARKER LIST 1'"  
 'queries the content of the 'MARKER LIST 1' tag of the selected control list file.

Response: "'0:0;10:1;20:0;30:1'"  
 'the marker setting for samples 0 to 9 = 0 (low), for 10 to 19 = 1 (high) and for 20 to 29 = 0. From sample 30 onward the marker setting = 1.

**Example:** {LEVATT LIST 1: 0:0;10:1;20:0;30:1}

**IEC bus query:** ":BB:DM:CLIS:TAG? 'LEVATT LIST 1'"  
 'queries the content of the 'LEVATT LIST 1' tag of the selected control list file.

Response: "'0:0;10:1;20:0;30:1'"  
 'level attenuation applies to data values 10 to 19 (high) and from data value 30 onward.

**{WAVEFORM-Length: #I<sub>0</sub>Q<sub>0</sub>I<sub>1</sub>Q<sub>1</sub>...I<sub>x</sub>Q<sub>x</sub>...I<sub>N-1</sub>Q<sub>N-1</sub>...}** (mandatory for waveforms)

The tag contains the actual waveform data and consists of the following:

**Length** 'Length' specifies the number of bytes in a WAVEFORM tag and consists of the following:

+ Length of ", #" (1 byte)

+ Number of I/Q pairs \* 4 (2 bytes per I and per Q value).

I<sub>x</sub>Q<sub>x</sub>... represents binary data (16-bit signed integer in 2's complement notation) containing the I and Q component alternately and starting with the I component. Each component consists of two bytes, least significant byte (LSB) first.

The values of the two bytes in an I component and a Q component are in the range -32767 to +32767. This value is transferred to the D/A converter.

At 50 Ω between the inner and outer conductors of the I and Q outputs, an amplitude V<sub>p</sub> of +/-0.5 Volt arises on the I/Q output connectors of the R&S Signal Generator. When a PEP offset is defined (PEP OFFSET tag) the amplitude is correspondingly reduced.

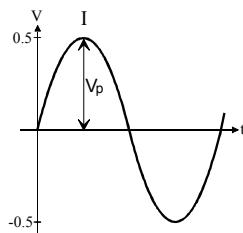

(The illustration also applies to the Q output)

**Example:**

{WAVEFORM-401:#I,Q,I,Q,I,Q...I,Q} (100 I/Q pairs with 4 bytes each are transmitted)

**IEC bus query:**

The data is transmitted using IEC bus command `BB:ARB:WAVE:DATA`.

## Creating a Waveform Manually

We will use the example of a sine function in the I channel and a cosine function in the Q channel, each with 20 points, to explain how a waveform file SICO.WV is generated.

The sine and cosine values are calculated by a short program written in the programming language C (see the following example for creating a C-program). They are stored in the file SICO.TXT as follows:

**Contents of SICO.TXT:**

Sine (I)    Cosine (Q)

```
0.000000 1.000000
0.309017 0.951057
0.587785 0.809017
0.809017 0.587785
0.951057 0.309017
1.000000 -0.000000
0.951056 -0.309017
0.809017 -0.587785
0.587785 -0.809017
0.309017 -0.951056
-0.000000 -1.000000
-0.309017 -0.951057
-0.587785 -0.809017
-0.809017 -0.587785
-0.951056 -0.309017
-1.000000 0.000000
-0.951056 0.309017
-0.809017 0.587785
-0.587785 0.809017
-0.309017 0.951057
```

The decimal values in SICO.TXT should be normalized such that they are between  $-1.0$  and  $+1.0$ .

The waveform file SICO.WV will be based on the contents of this file.

To be read by the R&S Signal Generator these waveform data must be coded binary and packed into an appropriate WAVEFORM tag.

A tag consists of a name and a data set and is enclosed in curved brackets. The tag is a kind of label carrying information about what the R&S Signal Generator should do with the data set (see above and step 3 of the following instructions).

The following steps outline how to create the waveform file SICO.WV:

**Step 1**

The values from the file SICO.TXT must be converted into binary format consisting of integer numbers without a sign and with 16-bit width. The numeric range between -1.0 and +1.0 corresponds to the modulation range of the waveform D/A converter of  $65535 (2^{16}-1)$ .

```
+1.0 -> 32767 = 0x7FFF
0.0 -> 0 = 0x0000
-1.0 -> -32767 = 0x8001
```

A further C-program is suitable for creating the binary data set from the ASCII values stored in SICO.TXT file (see following example for creating a C-program). This program stores the binary data set to a file called SICO.WV.

The contents of the file SICO.WV reads as follows:

```
IQIQIQIQIQIQI ... IQ
```

**Explanation:**

There is no readable representation for binary values in this document. This is why we use the sequence IQIQIQ to characterize the binary code in the present example.

**Step 2**

The file SICO.WV now contains the binary data set corresponding to the 20 I/Q pairs. Before this binary data set can be further processed in step 3, the TYPE and the CLOCK tag

```
{TYPE: SMU-WV, xxxxxxxx}
{CLOCK: yyy} must be placed in front.
```

**The TYPE tag must be the first entry in a WAVEFORM.** The TYPE tag identifies the waveform as a valid R&S Signal Generator waveform.

**SMU-WV** denotes that the waveform is self-contained.

**Xxxxxxx** is the checksum of the waveform. To simplify our example 0 is used, i.e., the R&S Signal Generator does not evaluate a checksum.

**The TYPE tag** informs the R&S Signal Generator about the clock rate of the waveform.

**yyy** is the clock frequency at which the waveform has to be output, in Hz

To enter the TYPE tag in the SICO.WV file an ASCII editor which is able to handle binary data as well, e.g. the Microsoft Windows editor **NOTEPAD.EXE**, must be used.

Now the contents of the SICO.WV file read:

```
{TYPE: SMU-WV, 0}
{CLOCK: 10e6}
IQIQIQIQIQIQIQIQIQIQI ... IQ
```



**Step 3**

The binary data must now be packed into a WAVEFORM tag with the following structure:

`{WAVEFORM-Length: □#IQIQIQIQIQIQIQIQIQI ... IQ}`

The WAVEFORM tag consists of the following characters and data:

- { Opens each tag.
- WAVEFORM** Name of the tag for waveform.
- Separates the name from the length indication.
- Length** Length of the data set  
**Length** indicates the number of bytes of the data set and consists of:
  - + length of "#" (1 byte)
  - + number of I/Q pairs \* 4 (2 bytes per I and per Q value).

In our example containing a sine and a cosine with 20 pairs for each wave, the resulting length is **81**.
- : □ Separates the name and length from the remainder of the data set. The blank □ can be omitted.
- # Indicates the beginning of the binary data.
- IQIQIQ** Binary data set.  
 The binary data contain the I and Q values in alternate order, the first value is an I value. Each value consists of 2 Bytes, starting with the least significant bit.
- } Terminates each tag.

The editor mentioned above which can handle binary data is now used to place the string "{WAVEFORM-81: #" in front and '}' at the end of the data set.

The contents of the waveform file SICO.WV for 20 I/Q pairs is now ready for operation and reads.

```

{TYPE: SMU-WV,0}
{CLOCK: 10e6}
{WAVEFORM-81: □#IQIQIQIQIQIQIQIQIQI ... IQ}
```

20 I/Q pairs = 80 bytes
81 bytes

The tags TYPE, CLOCK and WAVEFORM are mandatory for each waveform. All other tags are optional and can be inserted after the TYPE tag in arbitrary order, e.g.

```

{TYPE: SMU-WV,0}
{COMMENT: I/Q=sine/cosine, 20 points, clock 10 MHz}
{CLOCK: 10e6}
{Samples:20}
{WAVEFORM-81:#IQIQIQIQIQIQIQIQIQI ... IQ}
```

C-program for creating the file SICO.TXT containing 20 sine and cosine pairs:

```
#include <stdlib.h>
#include <stdio.h>
#include <math.h>

void main(void)
{
    const unsigned int samples = 20;
    const float pi = 3.141592654;
    float grad, rad;
    FILE *fp;
    int i;

    fp = fopen("SICO.TXT", "w");
    if (fp == 0)
        return;

    for (i=0; i<samples; i++)
    {
        grad = (360.0 / (float)samples) * (float)i;
        rad = grad * (pi / 180.0);

        fprintf(fp, "%f %f\n", sin(rad), cos(rad));
    }

    fclose(fp);
}
```

Contents of the file  
SICO.TXT:

Sine (I)	Cosine (Q)
0.000000	1.000000
0.309017	0.951057
0.587785	0.809017
0.809017	0.587785
0.951057	0.309017
1.000000	-0.000000
0.951056	-0.309017
0.809017	-0.587785
0.587785	-0.809017
0.309017	-0.951056
-0.000000	-1.000000
-0.309017	-0.951057
-0.587785	-0.809017
-0.809017	-0.587785
-0.951056	-0.309017
-1.000000	0.000000
-0.951056	0.309017
-0.809017	0.587785
-0.587785	0.809017
-0.309017	0.951057

**Extract from a C-program generating a binary data set from the I/Q pairs in the file SICO.TXT and storing the result to file SICO.WV:**

```
#include <stdlib.h>
#include <stdio.h>
#include <math.h>

void main(void)
{
    const unsigned int samples = 20; // Number of samples to convert
    FILE *fp_sour, *fp_dest;
    float i_float, q_float;
    unsigned short i_usint, q_usint;
    int i;

    fp_sour = fopen("SICO.TXT", "rt");
    if (fp_sour == 0)
        return;
    fp_dest = fopen("SICO.WV", "wb");
    if (fp_dest == 0)
    {
        fclose(fp_sour);
        return;
    }

    // Write required tags to waveform file
    fprintf(fp_dest, "{TYPE: SMU-WV,0}");
    fprintf(fp_dest, "{CLOCK: 10e6}");
    fprintf(fp_dest, "{SAMPLES: %d}", samples);
    fprintf(fp_dest, "{WAVEFORM-%d:#", (samples * 4) + 1);

    for (i=0; i<samples; i++)
    {
        // Read I/Q pair from ASCII file
        if (fscanf(fp_sour, "%f %f", &i_float, &q_float) == EOF)
            break;

        // Convert I/Q pair to unsigned short
        i_usint = (unsigned short)floor((i_float * 32767.0) + 0.5);
        q_usint = (unsigned short)floor((q_float * 32767.0) + 0.5);

        // Write converted I/Q pair to waveform file
        fwrite(&i_usint, 2, 1, fp_dest);
        fwrite(&q_usint, 2, 1, fp_dest);
    }

    fprintf(fp_dest, "}");

    fclose(fp_dest);
    fclose(fp_sour);
}
```

# SOURce:BB:DM Subsystem - Remote-Control Commands

## Introduction - DM General Remote-Control Commands

The commands in the Source:BB:DM subsystem are described in two sections, separated into configuring digital modulation and lists for digital modulation.

The following section contains the commands for generating the digital modulation signal.

The keyword SOURce is optional and can be omitted.

The numeric suffix to SOURce distinguishes between signal generation for path A and path B in the case of two-path instruments:

[SOURce<1>] = path A  
 SOURce2 = path B

The keyword SOURce is optional in the case of commands for path A and can be omitted. For path B the command must contain the keyword with suffix 2.

For one-path instruments, the keyword SOURce is optional and can be omitted.

## Table of Commands - DM General Remote-Control Commands

Command	Parameter	Default unit	Note
[SOURce<[1] 2>]:BB:DM:ASK:DEPTH	0 ... 100	PCT	
[SOURce<[1] 2>]:BB:DM:CLOCK			Query only
[SOURce<[1] 2>]:BB:DM:CLOCK:MODE	SYMBOL   BIT   MSYMBOL		
[SOURce<[1] 2>]:BB:DM:CLOCK:MULTIPLIER	1 ... 64		
[SOURce<[1] 2>]:BB:DM:CLOCK:SOURce	COUPled   INTernal   EXTernal		
[SOURce<[1] 2>]:BB:DM:CODing	OFF   APCO25   APCO25FSK   CDMA2000   DIFF   DPHS   DGRay   EDGE   GRAY   GSM   ICO   NADC   PDC   PHS   TETRa   PWT   TFTS   INmarsat   VDL   WCDMa		
[SOURce<[1] 2>]:BB:DM:FILTer:PARAmeter:APCO25	0.15 ... 2.5		
[SOURce<[1] 2>]:BB:DM:FILTer:PARAmeter:COsine	0.05 ... 0.99		
[SOURce<[1] 2>]:BB:DM:FILTer:PARAmeter:GAUSS	0.15 ... 2.5		
[SOURce<[1] 2>]:BB:DM:FILTer:PARAmeter:LPASs	0.05 ... 2.0		
[SOURce<[1] 2>]:BB:DM:FILTer:PARAmeter:PGAus	0.15 ... 2.5		
[SOURce<[1] 2>]:BB:DM:FILTer:PARAmeter:RCOSine	0.05 ... 0.99		
[SOURce<[1] 2>]:BB:DM:FILTer:PARAmeter:SPHase	0.15 ... 2.5		
[SOURce<[1] 2>]:BB:DM:FILTer:TYPE	RCOSine   COSine   GAUSS   LGAuss   CONE   COF705   COEQUALizer   COFEQUALizer   C2K3x   APCO25   SPHase   RECTangle   PGAuss		

Command	Parameter	Default unit	Note
	LPASs   USER   DIRac   ENPShape   EWPSHape		
[SOURCE<[1]>]:BB:DM:FLIST:CATalog			Query only
[SOURCE<[1]>]:BB:DM:FLIST:DELeTe	<file name>		
[SOURCE<[1]>]:BB:DM:FLIST:FREE			Query only
[SOURCE<[1]>]:BB:DM:FLIST:POINTs			Query only
[SOURCE<[1]>]:BB:DM:FLIST:SELEct	<file name>		
[SOURCE<[1]>]:BB:DM:FORMat	ASK   BPSK   P2DBpsk   QPSK   QPSK45   OQPSk   P4QPsk   P4DQpsk   PSK8   P8D8psk   P8EDge   QAM16   QAM32   QAM64   QAM128   QAM256   QAM1024   QAM16EDge   QAM32EDge   MSK   FSK2   FSK4   USER   FSKVar   QEDGE		
[SOURCE<[1]>]:BB:DM:FSK:DEVIation	0.1 x Symbol Rate ... 1.5 x Symbol Rate	Hz	
[SOURCE<[1]>]:BB:DM:FSK:VARIABLE:TYPE	4FSK   8FSK   16 FSK		
[SOURCE<[1]>]:BB:DM:FSK:VARIABLE:SYMBOL<0...15>:DEVIation	-1.5 x Symbol Rate ... 1.5 x Symbol Rate (max 10 MHz)	Hz	
[SOURCE<[1]>]:BB:DM:MDELay?			Query only
[SOURCE<[1]>]:BB:DM:PATTERn	#B0 ... #B11...1, 1...64		
[SOURCE<[1]>]:BB:DM:PRAMP:ATTenuation	0.0 ... 50	dB	
[SOURCE<[1]>]:BB:DM:PRAMP:BBONLY[:STATE]	ON   OFF		
[SOURCE<[1]>]:BB:DM:PRAMP:FDELay	-4.0 ... +4.0 symbols		
[SOURCE<[1]>]:BB:DM:PRAMP:RDELay	-4.0 ... +4.0 symbols		
[SOURCE<[1]>]:BB:DM:PRAMP:SHAPE	LINear   COSine		
[SOURCE<[1]>]:BB:DM:PRAMP:SOURCE	INTernal   EXTernal		
[SOURCE<[1]>]:BB:DM:PRAMP[:STATE]	ON   OFF		
[SOURCE<[1]>]:BB:DM:PRAMP:TIME	0.25 ... 32 symbols		
[SOURCE<[1]>]:BB:DM:PRBS[:LENGTH]	9   11   15   16   20   21   23		
[SOURCE<[1]>]:BB:DM:PRESet			
[SOURCE<[1]>]:BB:DM:SEQuence	AUTO   RETRigger   AAUTO   ARETrigger   SINGLE		
[SOURCE<[1]>]:BB:DM:SOURCE	ZERO   ONE   PRBS   PATTERN   DLIST   SERIAL   PARAllel   LAN   USB		
[SOURCE<[1]>]:BB:DM:SRATE	400 Hz ... 15 MHz (FSK) / 27 MHz	Hz	
[SOURCE<[1]>]:BB:DM:STANDARD	USER   BLUetooth   CFORward   CREVerse   DECT   ETC   GSM   GSMEdge   NADC   PDC   PHS   TDSCdma   TETRa   TFTS   W3GPP		

Command	Parameter	Default unit	Note
	WORLdspace		
[SOURce<[1] 2>]:BB:DM:STATe	ON   OFF		
[SOURce<[1] 2>]:BB:DM:SWITChing:SOURce	INTernal   EXTernal		
[SOURce<[1] 2>]:BB:DM:SWITChing:STATe	ON   OFF		
[SOURce<[1] 2>]:BB:DM:TRIGGer:ARM:EXECute	-		No query
[SOURce<[1] 2>]:BB:DM:TRIGGer:EXECute	-		No query
[SOURce<[1] 2>]:BB:DM:TRIGGer[EXTernal<[1] 2>]:DELay	0 ... 2 <sup>16</sup> - 1 Symbols		
[SOURce<[1] 2>]:BB:DM:TRIGGer[EXTernal<[1] 2>]:INHibit	0 ... 2 <sup>26</sup> - 1 Symbols		
[SOURce<[1] 2>]:BB:DM:TRIGGer:OBASeband:DELay	0 ... 2 <sup>16</sup> - 1 Symbols		
[SOURce<[1] 2>]:BB:DM:TRIGGer:OBASeband:INHibit	0 ... 2 <sup>26</sup> - 1 Symbols		
[SOURce<[1] 2>]:BB:DM:TRIGGer:OUTPut<[1]...4>:DELay	0 ... 2 <sup>20</sup> - 1 Symbols		
[SOURce<[1] 2>]:BB:DM:TRIGGer:OUTPut:DELay:FIXed	ON   OFF	Hz	
[SOURce<[1] 2>]:BB:DM:TRIGGer:OUTPut<[1]...4>:DELay:MAX?			Query only
[SOURce<[1] 2>]:BB:DM:TRIGGer:OUTPut<[1]...4>:DELay:MIN?			Query only
[SOURce<[1] 2>]:BB:DM:TRIGGer:OUTPut<[1]...4>:MODE	CLISt   PULSe   PATtern   RATio		
[SOURce<[1] 2>]:BB:DM:TRIGGer:OUTPut<[1]...4>:OFFTime	1 ... (2 <sup>20</sup> - 1) symbols		
[SOURce<[1] 2>]:BB:DM:TRIGGer:OUTPut<[1]...4>:ONTime	1 ... (2 <sup>20</sup> - 1) symbols		
[SOURce<[1] 2>]:BB:DM:TRIGGer:OUTPut<[1]...4>:PATtern	#B0, 1 ... #B111...1,32		
[SOURce<[1] 2>]:BB:DM:TRIGGer:OUTPut<[1]...4>:PULSe:DIVider	2 ... 2 <sup>10</sup>		
[SOURce<[1] 2>]:BB:DM:TRIGGer:OUTPut<[1]...4>:PULSe:FREQ?			Query only
[SOURce<[1] 2>]:BB:DM:TRIGGer:RMODE			Query only
[SOURce<[1] 2>]:BB:DM:TRIGGer:SLENgth	1 ... 2 <sup>32</sup> -1 symbols		
[SOURce<[1] 2>]:BB:DM:TRIGGer:SOURce	INTernal   EXTernal   BEXTernal   OBASeband		

**[SOURce<[1]|2>]:BB:DM:ASK:DEPT** 0 ... 100 PCT

The command sets the ASK modulation depth when modulation type ASK is selected.

**Example:** " :BB:DM:FORM ASK"  
'selects the ASK modulation type.

" :BB:DM:ASK:DEPT 50 PCT"  
'sets a modulation depth of 50 percent.

*RST value	Resolution	SCPI
100 PCT	0.1 PCT	Device-specific

**[SOURce<[1]|2>]:BB:DM:CLOCK:MODE** SYMBol | BIT | MSYMBol

The command enters the type of externally supplied clock (:BB:DM:CLOCK:SOURce EXTERNAL). The bit clock and the symbol clock differ only in the case of modulations that have more than two states, i.e. that require more than one bit for encoding each state. When MSYMBOL is used, a multiple of the symbol clock is supplied via the CLOCK connector and the symbol clock is derived internally from this. The multiplier is entered with the command :BB:DM:CLOCK:MULTIPLIER.

For two-path instruments, the only numerical suffix allowed for SOURce is 1, since the external clock source is permanently allocated to path A.

**Example:**           ":BB:DM:CLOCK:MODE SYMB"  
                  'selects clock type **Symbols**, i.e. the supplied clock is a symbol clock.

*RST value	Resolution	Dependencies	SCPI
SYMBOL	-	It is not possible to select BIT and MSYMBOL in the case of an external serial or external parallel data source (not available) (SOUR:BB:DM:SOUR SER and PAR).	Device-specific

**[SOURce<[1]|2>]:BB:DM:CLOCK:MULTIPLIER** 1 ... 64

The command specifies the multiplier for clock type **Multiple Symbols** (:BB:DM:CLOCK:MODE MSYM) in the case of an external clock source.

For two-path instruments, the only numerical suffix allowed for SOURce is 1, since the external clock source is permanently allocated to path A.

**Example:**           ":BB:DM:CLOCK:SOUR EXT"  
                  'selects the external clock source. The clock is supplied via the CLOCK connector.

                  ":BB:DM:CLOCK:MODE MSYM"  
                  'selects clock type **Multiple Symbols**, i.e. the supplied clock has a rate which is a multiple of the symbol rate.

                  ":BB:DM:CLOCK:MULT 12"  
                  'the multiplier for the external clock rate is 12.

*RST value	Resolution	SCPI
4	1	Device-specific

**[SOURce<[1]|2>]:BB:DM:CLOCK:SOURce** COUPLed | INTernal | EXTERNAL

The command selects the source for the digital modulation clock.

For two-path instruments, selecting COUPLed and EXTERNAL is only possible for path A, since the external clock source is permanently allocated to path A.

**Parameter:**       **INTERNAL**  
                  The internal clock reference is used.

**EXTERNAL**  
                  The external clock reference is supplied to the CLOCK connector.

**COUPLed**  
                  The clock reference (internal or external) is selected automatically according to the selected data source.

**Example:**       ":BB:DM:CLOC:SOUR INT"  
                  'selects the internal clock reference.

*RST value	Resolution	Dependencies	SCPI
INTernal	-	When COUPlEd is selected and the data source is changed (:BB:DM:DATA:SOUR) the clock source is automatically changed correspondingly as well	Device-specific

[SOURce<[1]>]:BB:DM:CODing OFF|APCO25|APCO25FSK|CDMA2000|DIFF|DPHS|DGRay|EDGE|GRAY|GSM|ICO|NADC|PDC|PHS|TETRA|PWT|TFTS|INMarsat|VDL|WCDMa

The command selects the modulation coding.

**Parameter:**       **DPHS**  
                          Phase Difference  
  
                  **DGRay**  
                          Difference + Gray  
  
                  ...

**Example:**       ":BB:DM:COD GRAY"  
                  'selects GRAY coding. This coding is valid for all modulation types.

*RST value	Resolution	Dependencies	SCPI
INTernal	-	If the modulation type selected (:BB:DM:FORM) is not possible with the coding that has been set, it is automatically set to OFF (:BB:DM:COD OFF). When a standard is selected (:BB:DM:STAN), the coding is set to the default value.	Instrum-ent-specific

[SOURce<[1]>]:BB:DM:FILTer:PARAmeter?

Queries the filter parameter of the selected filter.

**Example:**       ":BB:DM:FILT:TYPE?"  
                  'queries the filter type.  
  
                  Response: LPAS  
  
                  ":BB:DM:FILT:PAR?"  
                  'queries the filter parameter.  
  
                  Response: 0.5

*RST value	Resolution	SCPI
-	0.01	Device-specific

[SOURce<[1]>]:BB:DM:FILTer:PARAmeter:APCO25 0.05 ... 0.99

The command sets the roll-off factor for filter type APCO25.

**Example:**       ":BB:DM:FILT:PAR:APCO25 0.2"  
                  'sets the roll-off factor to 0.2 for filter type APCO25.

*RST value	Resolution	Dependencies	SCPI
0.20	0.01	On selecting filter APCO25, the filter parameter is set to the default value.	Device-specific



**[SOURce<[1]>]:BB:DM:FILTer:PARAmeter:COsine 0.05 ... 0.99**

The command sets the roll-off factor for the Cosine filter type.

**Example:**       ":BB:DM:FILT:PAR:COs 0.35"  
                  'sets the roll-off factor to 0.35 for filter type Cosine.

*RST value	Resolution	Dependencies	SCPI
0.35	0.01	On selecting the Cosine filter , the filter parameter is set to the default value.	Device-specific

**[SOURce<[1]>]:BB:DM:FILTer:PARAmeter:GAUSs 0.15 ... 2.5**

The command sets the roll-off factor for the Gauss filter type.

**Example:**       ":BB:DM:FILT:PAR:GAUS 0.5"  
                  'sets B x T to 0.5 for the Gauss filter type.

*RST value	Resolution	Dependencies	SCPI
0.3	0.01	On selecting the GAUSS filter or a standard (:BB:DM:STAN) which uses the GAUSS filter, the filter parameter is set to the default value.	Device-specific

**[SOURce<[1]>]:BB:DM:FILTer:PARAmeter:PGAuss 0.15 ... 2.5**

The command sets the roll-off factor for the Pure Gauss filter type.

**Example:**       ":BB:DM:FILT:PAR:PGA 0.5"  
                  'sets B x T to 0.5 for the Pure Gauss filter type.

*RST value	Resolution	Dependencies	SCPI
0.3	0.01	On selecting the Pure GAUSS filter the filter parameter is set to the default value.	Device-specific

**[SOURce<[1]>]:BB:DM:FILTer:PARAmeter:LPASs 0.05 ... 2.0**

The command sets the cut off frequency factor for the Lowpass filter type. The value range depends on the set symbol rate.

**Example:**       ":BB:DM:FILT:PAR:LPAS 0.5"  
                  'the cut of frequency factor is set to 0.5.

*RST value	Resolution	SCPI
0.50		Device-specific

**[SOURce<[1]>]:BB:DM:FILTer:PARAmeter:RCOSine 0.05 ... 0.99**

The command sets the roll-off factor for the Root Cosine filter type.

**Example:**       ":BB:DM:FILT:PAR:RCOS 0.22"  
                  'sets the roll-off factor to 0.22 for filter type Root Cosine.

*RST value	Resolution	Dependencies	SCPI
0.35	0.01	On selecting the Root Cosine filter or a standard (:BB:DM:STAN) which uses the Root Cosine filter, the filter parameter is set to the default value.	Device-specific

**[SOURce<[1]>]:BB:DM:FILTer:PARameter:SPHase 0.15 ... 2.5**

The command sets B x T for the Split Phase filter type.

**Example:**       ":BB:DM:FILT:PAR:SPH 0.5"  
                  'sets B x T to 0.5 for the Split Phase filter type.

*RST value	Resolution	Dependencies	SCPI
2	0.01	On selecting the Split Phase filter or a standard (:BB:DM:STAN) which uses the Split Phase filter, the filter parameter is set to the default value.	Device-specific

**[SOURce<[1]>]:BB:DM:FILTer:TYPE RCOSine | COSine | GAUSs | LGAuss | CONE | COF705 | COEqualizer | COFequalizer | C2K3x | APCO25 | SPHase | RECTangle | PGAuss | LPASs | USER | DIRac | ENPShape | EWPSHape**

The command selects the filter type.

**Example:**       ":BB:DM:FILT:TYPE COS"  
                  'selects the Cosine filter type.

*RST value	Resolution	Dependencies	SCPI
GAUSs	-	When a standard is selected (:BB:DM:STAN), the filter type and filter parameter are set to the default value.	Device-specific

**[SOURce<[1]>]:BB:DM:FORMat ASK | BPSK | P2DBpsk | QPSK | QPSK45 | OQPSk | P4QPsK | P4DQpsk | PSK8 | P8D8psk | P8EDge | QAM16 | QAM32 | QAM64 | QAM128 | QAM256 | QAM1024 | QAM16EDge | QAM32EDge | MSK | FSK2 | FSK4 | USER | FSKVar | QEDGe**

The command selects the modulation type.

**Example:**       ":BB:DM:FORM QPSK"  
                  'selects modulation type QPSK.

*RST value	Resolution	Dependencies	SCPI
MSK	-	If the coding that is set (:BB:DM:COD) is not possible with the modulation type selected, it is automatically set to OFF (:BB:DM:COD OFF). When a standard is selected (:DM:STAN), the modulation type is set to the default value.	Device-specific

**[SOURce<[1]>]:BB:DM:FSK:DEVIation <numeric\_value>**

The command sets the frequency deviation when FSK modulation is selected. The range of values depends on the symbol rate that is set (see data sheet) and the maximum deviation is 10 MHz.

**Example:**       ":BB:DM:FORM FSK"  
                  'selects FSK modulation.  
  
                  ":BB:DM:FSK:DEV 10 MHz"  
                  'sets the frequency deviation to 10 MHz.

*RST value	Resolution	Dependencies	SCPI
Symbol rate/2	0.5 Hz	If the symbol rate that is set exceeds the maximum possible value for the chosen frequency deviation, it is suitably adapted (:BB:DM:SRAT).	Device-specific

**[SOURCE<[1]>]:BB:DM:FSK:VARIABLE:SYMBOL<0...15>:DEVIATION <numeric\_value>**

The command sets the deviation of the selected symbol for variable FSK modulation mode. The number of symbols (and therefore the suffix range) depends on the selected FSK modulation type. The range of values depends on the symbol rate that is set (see data sheet) and the maximum deviation is 10 MHz.

**Example:**       ":BB:DM:FORM FSKV"  
                  'selects Variable FSK modulation.  
                  ":BB:DM:FSK:VAR:TYPE FSK16"  
                  'selects 16FSK modulation.  
                  ":BB:DM:FSK:VAR:SYMBOL:DEV 135000"  
                  'sets the frequency deviation of the least significant symbol to 135 kHz.

*RST value	Resolution	SCPI
-	0.5 Hz	Device-specific

**[SOURCE<[1]>]:BB:DM:FSK:VARIABLE:TYPE FSK4 | FSK8 | FSK16**

The command selects the modulation type for Variable FSK.

**Example:**       ":BB:DM:FORM FSKV"  
                  'selects Variable FSK modulation.  
                  ":BB:DM:FSK:VAR:TYPE FSK16"  
                  'selects 16FSK modulation.

*RST value	Resolution	SCPI
-	-	Device-specific

**[SOURCE<[1]>]:BB:DM:MDELAY?**

The command queries the digital modulation delay from the data input to the I/Q output in the case of external modulation.

This command is a query and therefore has no \*RST value.

**Example:**       "BB:DM:MDEL?"  
                  'queries the delay in the case of external modulation.  
                  Response: '0.4 ms'  
                  'the delay is 0.4 ms.

*RST value	Resolution	SCPI
-	-	Device-specific

**[SOURCE<[1]>]:BB:DM:PATTERN #B0 ... #B11...1, 1...64**

The command selects the data pattern for the internal data when PATTERN is selected as the data source. The maximum length is 64 bits.

**Example:**       ":BB:DM:SOUR PATT"  
                  'selects Pattern as the data source for digital modulation.  
                  ":BB:DM:PATT #B01110111010101010,17"  
                  'generates the user-defined sequence of 0/1 data.

*RST value	Resolution	SCPI
#B0,1	-	Device-specific

[SOURCE<[1]>]:BB:DM:PRAMP:ATTenuation 0.0 ... 70 dB

The command sets the level attenuation for signal ranges that are flagged with level attribute **attenuated** by the LEV\_ATT control signal.

**Example:**           ":BB:DM:PRAM:ATT 15 dB"  
                          'sets a level attenuation of 15 dB.

*RST value	Resolution	SCPI
15 dB	0.01 dB	Device-specific

[SOURCE<[1]>]:BB:DM:PRAMP:BBONLY[:STATe] ON | OFF

**Note:**  
*This command is available for SMx instruments only.*

This command selects power ramping in the baseband only or mixed power ramping in the baseband and the RF section.

The **ON** setting is mandatory if, with power ramping active, only the baseband signal is output (I/Q outputs), or, in case of two-path instruments, if a baseband signal is applied to two RF paths (RF A and RF B).

Only then can a signal with a defined, predictable level be output.

**Example:**           ":BB:DM:PRAM:BBON ON"  
                          'selects power ramping in the baseband only.

*RST value	Resolution	SCPI
OFF		Device-specific

[SOURCE<[1]>]:BB:DM:PRAMP:FDElay - 4.0 ... + 4.0 Symbols

The command sets the delay in the falling edge. A positive value gives rise to a delay and a negative value causes an advance. The setting is expressed in symbols.

**Example:**           ":BB:DM:PRAM:FDEL 1 "  
                          'the falling edge starts 1 symbol later.

*RST value	Resolution	SCPI
0 symbols	0.1 symbol	Device-specific

[SOURCE<[1]>]:BB:DM:PRAMP:RDElay - 4.0 ... + 4.0 Symbols

The command sets the delay in the rising edge. A positive value gives rise to a delay and a negative value causes an advance. The setting is expressed in symbols.

**Example:**           ":BB:DM:PRAM:RDEL 1 "  
                          'the rising edge starts 1 symbol later.

*RST value	Resolution	SCPI
0 symbols	0.1 symbol	Device-specific

**[SOURce<[1]>]:BB:DM:PRAMP:SHAPE** LINear | COSine

The command sets the edge shape of the ramp envelope.

**Example:**       "`:BB:DM:PRAM:SHAP COS`"  
                  'selects a cosine-shaped rise and fall for the transmitted power edge.

*RST value	Resolution	SCPI
COSine	-	Device-specific

**[SOURce<[1]>]:BB:DM:PRAMP:SOURce** INTernal | EXTernal

The command sets the source for the power ramp control signals.

**Parameter:**    **INTernal**  
                  The internal control signals LEV\_ATT and BURST are used. Control signals are stored in dedicated lists. When remote control is in use, the list to be used is defined, selected and enabled with the aid of `SOURce:BB:DM:CLISt:...` commands.

**EXTernal**  
                  The digital control signals LEV\_ATT and BURST are supplied via the control signal inputs on the AUX I/O connector.

**Example:**       "`:BB:DM:PRAM:SOUR EXT`"  
                  'enables the use of external control signals for power ramp control. The signals must be supplied via the AUX I/O interface.

*RST value	Resolution	SCPI
INTernal	-	Device-specific

**[SOURce<[1]>]:BB:DM:PRAMP[:STATE]** ON | OFF

The command enables or disables power ramping.

**Example:**       "`:BB:DM:PRAM:STAT ON`"  
                  'switches power ramping on.

*RST value	Resolution	SCPI
OFF		Device-specific

**[SOURce<[1]>]:BB:DM:PRAMP:TIME** 0.25 ... 16 Symbols

The command sets the power ramping rise time and fall time for a burst.

**Example:**       "`:BB:DM:PRAM:TIME 2`"  
                  'sets a time of 2 symbols for the edges to rise and fall.

*RST value	Resolution	SCPI
1 symbol	0.1 symbol	Device-specific

[SOURce<[1]|2>]:BB:DM:PRBS[:LENGth] 9 | 11 | 15 | 16 | 20 | 21 | 23

The command defines the length of the pseudo-random sequence in accordance with the following equation:

$$\text{Length} = (2^{\text{LENGth}}) - 1$$

**Example:** " :BB:DM:SOUR PRBS "  
 'the internal pseudo-random generator is used as the data source.  
 " :BB:DM:PRBS 9 "  
 'an internal pseudo-random sequence of 511 bits will be generated.

*RST value	Resolution	SCPI
9	-	Device-specific

[SOURce<[1]|2>]:BB:DM:PRESet

The command calls the default settings for digital modulation.

The command triggers an action and therefore has no \*RST value and no query form.

**Example:** " :BB:DM:PRES "  
 'calls the default settings for DM.

*RST value	Dependencies	SCPI
-	:BB:DM:CLOC:DEL	0
	:BB:DM:CLOC:MODE	SYMB
	:BB:DM:CLOC:SOUR	INT
	:BB:DM:CLOC:COD	GSM
	:BB:DM:FILT:PAR:APC	0.2
	:BB:DM:FILT:PAR:COS	0.35
	:BB:DM:FILT:PAR:GAUS	0.5
	:BB:DM:FILT:PAR:RCOS	0.22
	:BB:DM:FILT:PAR:SPH	0.1
	:BB:DM:FILT:TYPE	RCOS
	:BB:DM:FORM	MSK
	:BB:DM:FSK:DEV	135.417kHz
	:BB:DM:PATT	#H0,1
	:BB:DM:PRAM:ATT	15 dB
	:BB:DM:PRAM:ROFF	0
	:BB:DM:PRAM:FOFF	0
	:BB:DM:PRAM:SHAP	COS
	:BB:DM:PRAM:SOUR	INT
	:BB:DM:PRAM	OFF
	:BB:DM:PRAM:TIME	1 Symb
	:BB:DM:PRBS	9
	:BB:DM:SEQ	AUTO
	:BB:DM:SOUR	PRBS
	:BB:DM:SRAT	270.833 kHz
	:BB:DM:STAN	GSM
	:BB:DM:TRIG:DEL	0
	:BB:DM:TRIG:INH	0
	:BB:DM:TRIG:OUTP:DEL	0
	:BB:DM:TRIG:OUTP:MODE	FRAM
	:BB:DM:TRIG:OUTP:PER	1
	:BB:DM:TRIG:SOUR	INT

**[SOURce<[1]|2>]:BB:DM:SEQUence** AUTO | RETRigger | AAUTo | ARETrigger | SINGle

The command selects the trigger mode.

**Parameter:**       **AUTO**

The modulation signal is generated continuously.

**RETRigger**

The modulation signal is generated continuously. A trigger event (internal or external) causes a restart.

**AAUTo**

The modulation signal is generated only when a trigger event occurs. After the trigger event the signal is generated continuously. Signal generation is stopped with command `SOUR:BB:DM:TRIG:ARM:EXEC` and started again when a trigger event occurs.

**ARETrigger**

The modulation signal is generated only when a trigger event occurs. The device automatically toggles to RETRIG mode. Every subsequent trigger event causes a restart. Signal generation is stopped with command `SOUR:BB:DM:TRIG:ARM:EXEC` and started again when a trigger event occurs.

**SINGle**

The modulation signal is generated only when a trigger event occurs. After the trigger event the signal is generated once to the set sequence length (`SOUR:BB:DM:TRIG:SLen`). Every subsequent trigger event causes a restart.

**Example:**

`" :BB:DM:SEQ AAUT "`

'sets the **Armed\_auto** trigger mode; the device waits for the first trigger (e.g. with `*TRG`) and then generates the signal continuously.

*RST value	Resolution	SCPI
AUTO	-	Device-specific

**[SOURce<[1]|2>]:BB:DM:SOURce** ZERO | ONE | PRBS | PATTErn | DLISt | SERial | PARAllel

The command selects the data source.

**Parameter:**       **ZERO**

An internally generated 0 data sequence is used.

**ONE**

An internally generated 1 data sequence is used.

**PRBS**

The pseudo-random sequence generator is used as the data source. The length of the random sequence is defined with the aid of command `SOURce:BB:DM:PRBS`.

**PATTErn**

Internally generated data with a fixed pattern is used. The data pattern is defined using command `SOURce:BB:DM:PATTErn`.

**DLISt**

Data from the selected data list is used.

**SERial**

External data from the serial interface is used (in case of two-path instruments, path A).

**PARAllel**

External data from the serial interface is used (in case of two-path instruments, path A).

**Example:**     ":BB:DM:SOUR DLIS"  
                   'the internal data generator is used.  
                   ":BB:DM:DLIS:SEL 'test'"  
                   'the data list 'test.dm\_iqd' is used.

*RST value	Resolution	SCPI
PRBS	-	Device-specific

**[SOURce<[1]]>:BB:DM:SRATe** 400 Hz ... 15 MHz (FSK) / 25 MHz

The command sets the symbol rate. The value range is dependent on the selected modulation type. On changing to an FSK modulation type, excessively high values are automatically limited to the maximum value that can be set for FSK (see data sheet). The symbol rate can be entered in Hz/kHz/MHz or Symb/s / kSymb/s and MSymb/s.

When a standard is selected (DM:STANdard), the symbol rate is automatically set to the appropriate default value.

**Example:**     ":BB:DM:SRAT 10 MHz"  
                   'sets a symbol rate of 10 MHz.

*RST value	Resolution	Dependencies	SCPI
270.833 kHz	0.001 Hz	The value range is dependent on the selected modulation type (:BB:DM:FORM). When a standard is selected (:BB:DM:STAN), the symbol rate is set to the default value.	Device-specific

**[SOURce<[1]]>:BB:DM:STANdard** USER | BLUetooth | CFORward | CREVerse | DECT | ETC | GSM | GSMEdge | NADC | PDC | PHS | TDSCdma | TETRa | TFTS | W3GPp | WORLdspace

The command selects the standard. After selection, modulation parameters **Modulation Type**, **Symbol Rate**, **Filter** and **Coding** are automatically set in accordance with the standard. The USER parameter cannot be set. A query returns this value if a user-defined Custom Dig Mod setting was loaded or if one of the associated settings was changed subsequent to the selection of a standard. The user defined settings are stored and loaded with commands :BB:DM:STAN:ULIS:... (see following section "[Introduction - DM Lists - Remote-Control Commands](#)").

**Example:**     ":BB:DM:STAN DECT"  
                   'selects digital modulation according to the DECT standard.

*RST value	Resolution	Dependency	SCPI
GSM	-	Each selection sets the parameters :BB:DM:FORMat :BB:DM:SRATe :BB:DM:FILTer:TYPE :BB:DM:FILTer:PARAmeter:... :BB:DM:CODing and if necessary :BB:DM:FSK:DEV to the appropriate default values.	Device-specific



[SOURce<[1]|2>]:BB:DM:STATe ON | OFF

The command enables or disables digital modulation. Switching on digital modulation turns off all the other digital standards (in case of two-path instruments, this affects the same path).

**Example:**       ":BB:DM:STAT ON"  
                  'switches digital modulation on.

*RST value	Resolution	Dependency	SCPI
OFF	-	:BB:DM:STAT ON turns off all the other standards (in case of two-path instruments, this affects the same path).	Device-specific

[SOURce<[1]|2>]:BB:DM:SWITching:SOURce INTernal | EXTernal

The command selects the source of the CW control signal for switching between a modulated and an unmodulated signal.

**Parameter:**     **INTernal**  
                  The CW signal in the control list is used for the control. The internal signal can be output on one of the user interfaces.

**EXTernal**  
                  The control signal on the CW pin of the AUX I/Q connector is used (in case of two-path instruments, path A and B).

**Example:**       ":BB:DM:SWIT INT"  
                  'the CW signal in the control list is used for the control.

*RST value	Resolution	SCPI
INTernal	-	Device-specific

[SOURce<[1]|2>]:BB:DM:SWITching:STATe ON | OFF

The command enables switching between a modulated and an unmodulated signal.

**Example:**       ":BB:DM:SWIT:STAT INT"  
                  'CW switching is active.

*RST value	Resolution	SCPI
OFF	-	Device-specific

[SOURce<[1]|2>]:BB:DM:TRIGger:ARM:EXECute

The command stops signal generation for trigger modes Armed\_Auto and Armed\_Retrigger. A subsequent internal or external trigger event restart signal generation.

This command triggers an event and therefore has no \*RST value and no query form.

**Example:**       ":BB:DM:TRIG:SOUR INT"  
                  'sets internal triggering.

                  ":BB:DM:TRIG:SEQ ARET"  
                  'sets Armed\_Retrigger mode, i.e. every trigger event causes signal generation to restart.

                  ":BB:DM:TRIG:EXEC"  
                  'executes a trigger, signal generation is started.

```
" :BB:DM:TRIG:ARM:EXEC"
'signal generation is stopped.

" :BB:DM:TRIG:EXEC"
'executes a trigger, signal generation is started again.
```

*RST value	Resolution	SCPI
-	-	Device-specific

**[SOURce<[1]|2>]:BB:DM:TRIGger:EXECute**

The command executes a trigger. The internal trigger source must be selected using the command :BB:DM:TRIG:SOUR INT and a trigger mode other than AUTO must be selected using the command :BB:DM:TRIG:SEQ.

This command triggers an event and therefore has no \*RST value and no query form.

**Example:**

```
" :BB:DM:TRIG:SOUR INT"
'sets internal triggering.

" :BB:DM:TRIG:SEQ RETR"
'sets Retrigger mode, i.e. every trigger event causes signal generation to
restart.

" :BB:DM:TRIG:EXEC"
'executes a trigger.
```

*RST value	Resolution	SCPI
-	-	Device-specific

**[SOURce<[1]|2>]:BB:DM:TRIGger[:EXTErnal<[1]|2>]:DELay 0 ... 2<sup>16</sup>-1 Symbols**

The command specifies the trigger delay (expressed as a number of symbols) for external triggering. The numeric suffix to EXTErnal distinguishes between the external trigger via the TRIGGER 1 (suffix 1) and TRIGGER 2 (suffix 2) connector.

**Example:**

```
" :BB:DM:TRIG:SOUR EXT"
'selects an external trigger via the TRIGGER 1 connector.

" :BB:DM:TRIG:DEL 50"
'sets a delay of 50 symbols for the trigger.
```

*RST value	Resolution	SCPI
0 symbols	1 symbol for :BB:DM:CLOC:SOUR EXT  0.01 symbols for :BB:DM:CLOC:SOUR INT	Device-specific

**[SOURce<[1]|2>]:BB:DM:TRIGger:EXTErnal<[1]|2>:INHibit** 0 ... 2<sup>26</sup>-1 Symbols

The command specifies the number of symbols by which a restart is to be inhibited following a trigger event. This command applies only in the case of external triggering. The numeric suffix to EXTErnal distinguishes between the external trigger via the TRIGGER 1 (suffix 1) and TRIGGER 2 (suffix 2) connector.

**Example:**       ":BB:DM:TRIG:SOUR EXT"  
                  'selects an external trigger via the TRIGGER 1 connector.

                  ":BB:DM:TRIG:INH 200"  
                  'sets a restart inhibit for 200 symbols following a trigger event.

*RST value	Resolution	SCPI
0 symbols	1 symbol	Device-specific

**[SOURce<[1]|2>]:BB:DM:TRIGger:OBASeband:DELay** 0 ... 2<sup>16</sup>-1 Symbols**Note:**

*This command is available for SMx and AMU two-path instruments only.*

The command specifies the trigger delay (expressed as a number of symbols) for triggering by the trigger signal from the second path (two-path instruments only).

**Example:**       ":BB:DM:TRIG:SOUR OBAS"  
                  'sets for path A the internal trigger executed by the trigger signal from the second path (path B).

                  ":BB:DM:TRIG:OBAS:DEL 50"  
                  sets a delay of 50 symbols for the trigger.

*RST value	Resolution	SCPI
0 symbols	1 symbol for :BB:DM:CLOC:SOUR EXT	Device-specific
	0.01 symbols for :BB:DM:CLOC:SOUR INT	

**[SOURce<[1]|2>]:BB:DM:TRIGger:OBASeband:INHibit** 0 ... 2<sup>26</sup>-1 Symbols**Note:**

*This command is available for SMx and AMU two-path instruments only.*

The command specifies the number of symbols by which a restart is to be inhibited following a trigger event. This command applies only for triggering by the second path (two-path instruments only).

**Example:**       ":BB:DM:TRIG:SOUR OBAS"  
                  'sets for path A the internal trigger executed by the trigger signal from the second path (path B).

                  ":BB:DM:TRIG:INH 200"  
                  'sets a restart inhibit for 200 symbols following a trigger event.

*RST value	Resolution	SCPI
0 symbols	1 symbol	Device-specific

**[SOURce<[1]|2>]:BB:DM:TRIGger:OUTPut<[1]...4>:DELay 0 ... 100 000 Symbols**

The command defines the delay between the signal on the marker outputs and the start of the signal, expressed in terms of symbols. Command :BB:DM:TRIGger:OUTPut:DELay:FIXed can be used to restrict the range of values to the dynamic range, i.e. the range within which a delay of the marker signals can be set without restarting the marker and signal.

**Example:**           ":BB:DM:TRIG:OUTP2:DEL 16"  
                          'sets a delay of 16 symbols for the signal on connector MARKER 2.

*RST value	Resolution	SCPI
0 symbols	1 symbol	Device-specific

**[SOURce<[1]|2>]:BB:DM:TRIGger:OUTPut:DELay:FIXed ON | OFF**

The command restricts the marker delay setting range to the dynamic range. In this range the delay can be set without restarting the marker and signal. If a delay is entered in setting ON but is outside this range, the maximum possible delay is set and an error message is generated.

The numeric suffix in OUTPut has no significance for this command, since the setting always affects every marker.

**Example:**           ":BB:DM:TRIG:OUTP:DEL:FIX ON"  
                          'restricts the marker signal delay setting range to the dynamic range.

*RST value	Resolution	SCPI
OFF	-	Device-specific

**[SOURce<[1]|2>]:BB:DM:TRIGger:OUTPut<[1]...4>:DELay:MAXimum**

The command queries the maximum marker delay for setting :BB:DM:TRIG:OUTP:DEL:FIX ON.

The command is a query only and therefore has no \*RST value.

**Example:**           ":BB:DM:TRIG:OUTP:DEL:FIX ON"  
                          'restricts the marker signal delay setting range to the dynamic range.

                          ":BB:DM:TRIG:OUTP:DEL:MAX"  
                          'queries the maximum of the dynamic range.

Response: "2000"  
                          'the maximum for the marker delay setting is 2000 symbols.

*RST value	Resolution	SCPI
-	-	Device-specific

**[SOURce<[1]|2>]:BB:DM:TRIGger:OUTPut<[1]...4>:DELay:MINimum**

The command queries the minimum marker delay for setting :BB:DM:TRIGger:OUTPut:DELay:FIXed ON.

The command is a query only and therefore has no \*RST value.

**Example:**       ":BB:DM:TRIG:OUTP:DEL:FIX ON"  
                   'restricts the marker signal delay setting range to the dynamic range.  
                   ":BB:DM:TRIG:OUTP:DEL:MIN"  
                   'queries the minimum of the dynamic range.  
                   Response: "0"  
                   'the minimum for the marker delay setting is 0 symbols.

*RST value	Resolution	SCPI
-	-	Device-specific

**[SOURce<[1]|2>]:BB:DM:TRIGger:OUTPut<[1]...4>:MODE CLISt | PULSe | PATTeRn | RATio**

The command defines the signal for the selected marker output.

**Parameter:       CLISt**  
                   A marker signal that is defined in the selected control list is generated.

**PULSe**  
                   A pulsed marker signal is generated. The pulse frequency (= symbol rate/divider) is defined with the SOUR:BB:DM:TRIG:OUTP:PULSe:DIVider command and can be queried with the SOUR:BB:DM:TRIG:OUTP:PULSe:FREQuency? command.

**PATTeRn**  
                   A marker signal is generated with the aid of a user-definable bit pattern. The bit pattern is entered with the aid of command SOURce:BB:DM:TRIGger:OUTPut:PATTeRn . The bit pattern is a maximum of 32 bits long.

**RATio**  
                   A regular marker signal corresponding to the Time Off / Time On specifications in the commands SOURce:BB:DM:TRIGger:OUTPut:OFFT and SOURce:BB:DM:TRIGger:OUTPut:ONT is generated.

**Example:**       ":BB:DM:TRIG:OUTP2:MODE PULS"  
                   'selects the pulsed marker signal on output MARKER 2.

*RST value	Resolution	SCPI
RATio	-	Device-specific

**[SOURce<[1]|2>]:BB:DM:TRIGger:OUTPut<[1]...4>:OFFTime 1 ... 2^20 -1 symbol**

The command sets the number of symbols in a period (ON time + OFF time) during which the marker signal in setting SOURce:BB:DM:TRIGger:OUTPut:MODE RATio on the marker outputs is OFF.

**Example:**       ":BB:DM:TRIG:OUTP2:OFFT 20"  
                   'sets an OFF time of 20 symbols for marker signal 2 (in case of two-path instruments, on path A).

*RST value	Resolution	SCPI
1	1	Device-specific

**[SOURce<[1]|2>]:BB:DM:TRIGger:OUTPut<[1]...4>:ONTime 1 ... 2^20 -1 symbol**

The command sets the number of symbols in a period (ON time + OFF time) during which the marker signal in setting SOURce:BB:DM:TRIGger:OUTPut:MODE RATio on the marker outputs is ON.

**Example:**           ":BB:DM:TRIG:OUTP2:ONT 20"  
                          'sets an ON time of 20 symbols for marker 2 (in case of two-path instruments, on path A).

*RST value	Resolution	SCPI
1	1	Device-specific

**[SOURce<[1]|2>]:BB:DM:TRIGger:OUTPut<[1]...4>:PATTern #B0,1 ... #B111...1, 2**

The command defines the bit pattern used to generate the marker signal in the setting SOURce:BB:DM:TRIGger:OUTPut:MODE PATTern. 0 is marker off, 1 is marker on.

**Example:**           ":BB:DM:TRIG:OUTP2:PATT #B000000011111111,15"  
                          'sets a bit pattern.  
  
                          ":BB:DM:TRIG:OUTP2:MODE PATT"  
                          'activates the marker signal according to a bit pattern on output MARKER 2.

*RST value	Resolution	SCPI
#B,1	-	Device-specific

**[SOURce<[1]|2>]:BB:DM:TRIGger:OUTPut<[1]...4>:PULSe:DIVider 2 ... 2^10**

The command sets the divider for Pulse marker mode (SOUR:BB:DM:TRIGr:OUTP:MODE PULSe.). The resulting pulse frequency is derived by dividing the symbol rate by the divider.

**Example:**           ":BB:DM:TRIG:OUTP2:PULS:DIV 2"  
                          'sets the divider to 2 for the (in case of two path instruments, path A) marker signal on output MARKER 2.  
  
                          ":BB:DM:TRIG:OUTP2:FREQ?"  
                          'queries the resulting pulse frequency of the marker signal.  
  
Response: "66 000"  
                          'the resulting pulse frequency is 66 kHz.

*RST value	Resolution	SCPI
2	1	Device-specific

**[SOURce<[1]|2>]:BB:DM:TRIGger:OUTPut<[1]...4>:PULSe:FREQUency?**

The command queries the pulse frequency of the pulsed marker signal in the setting SOURce:BB:DM:TRIGger:OUTPut:MODE PULSe. The pulse frequency is derived by dividing the symbol rate by the divider.

The command is a query command and therefore has no \*RST value.

**Example:**       ":BB:DM:TRIG:OUTP2:PULS:DIV 2"  
'sets the divider (in case of two-path instruments; for the path A) marker signal on output MARKER 2 to the value 2.

":BB:DM:TRIG:OUTP2:MODE PULS"  
'enables the pulsed marker signal.

":BB:DM:TRIG:OUTP2:PULS:FREQ?"  
'queries the pulse frequency of the marker signal.

Response: "33 000"  
'the resulting pulse frequency is  
33 kHz.

*RST value	Resolution	SCPI
-	-	Device-specific

**[SOURce<[1]|2>]:BB:DM:TRIGger:RMODE**

The command displays the status of signal generation for all trigger modes with digital modulation on.

The command is a query command and therefore has no \*RST value.

**Parameter:**    **RUN**  
The signal is generated. A trigger event occurred in the triggered mode.

**STOP**  
The signal is not generated. A trigger event did not occur in the triggered modes, or signal generation was stopped by the command  
:BB:DM:TRIG:ARM:EXECute (armed trigger modes only).

**Example:**       "SOUR:BB:DM:TRIG:SOUR EXT"  
'sets external triggering via the TRIGGER 1 connector.

"SOUR:BB:DM:TRIG:MODE ARET"  
'selects the Armed\_Retrigger mode

"SOUR:BB:DM:TRIG:RMOD?"  
'queries the current status of signal generation.

Response: "RUN"  
'the signal is generated, an external trigger was executed.

*RST value	Resolution	SCPI
-	-	Device-specific

**[SOURce<[1]|2>]:BB:DM:TRIGger:SLENgth** 1 ... (2<sup>32</sup>-1) Symbols

The command defines the length of the signal sequence to be output in the **Single** trigger mode.

**Example:** "SOUR:BB:DM:SEQ SING"  
'sets trigger mode Single.

"SOUR:BB:DM:TRIG:SLEN 200"  
'sets a sequence length of 200 symbols. 200 symbols will be output after the next trigger event.

*RST value	Resolution	SCPI
1000 Symbols	-	Device-specific

**[SOURce<[1]|2>]:BB:DM:TRIGger:SOURce** INTernal | EXTernal | BEXTernal | OBASeband

The command selects the trigger source.

**Parameter: INTernal**  
Triggering is executed by means of the Trigger command SOURce:BB:DM:TRIGger:EXECute, TRIGger:BB:DM:IMMediate or \*TRG in the case of remote control and by means of **Execute Trigger** in the case of manual operation.

**EXTernal**  
Triggering is executed by means of the signal on the TRIGGER 1 connector.

**BEXTernal**  
Triggering is executed by means of the signal on the TRIGGER 2 connector.

**OBASeband**  
Triggering is executed by means of the trigger signal from the second path (two-path instruments only).

**Example:** ":BB:DM:TRIG:SOUR EXT"  
'sets external triggering via the TRIGGER 1 connector.

*RST value	Resolution	SCPI
INTernal	-	Device-specific



## Introduction - DM Lists - Remote-Control Commands

The following section brings together the commands for defining and managing the data lists and control lists for digital modulation.

Lists are stored as files with specific file extensions in a user-definable directory (see table). The directory which applies to the commands that follow is defined using the command `MMEMORY:CDIR`. Files in this directory can be accessed by quoting the file name. The path and extension are not needed.

List type	Content	File extension
Data List	Digital modulation data	*.dm_iqd
Control List	Digital modulation control data	*.dm_iqc
User Standards	User settings of digital modulation	*.dm_stu

It is not possible to use other file extensions with the commands. Attempting to do so will cause an error message. If the file extension is changed in any other way (e.g. by directly accessing the file system) the lists are no longer recognized and therefore invalid.

## Table of Commands - DM Lists

Command	Parameter	Default unit	Note
[SOURCE<[1]>]:BB:DM:CLIST:CATalog?			Query only
[SOURCE<[1]>]:BB:DM:CLIST:COPIY	<new_control_list_name>		No query
[SOURCE<[1]>]:BB:DM:CLIST:DATA	0   1, {0   1}   block data		No query
[SOURCE<[1]>]:BB:DM:CLIST:DELeTe	<control_list_name>		No query
[SOURCE<[1]>]:BB:DM:CLIST:POINts			Query only
[SOURCE<[1]>]:BB:DM:CLIST:SELeCt	<control_list_name>		Query only
[SOURCE<[1]>]:BB:DM:CLIST:TAG?	<control_list_name>, <tag_name>		Query only
[SOURCE<[1]>]:BB:DM:DLIST:CATalog?			Query only
[SOURCE<[1]>]:BB:DM:DLIST:COPIY	<new_data_list_name>		No query
[SOURCE<[1]>]:BB:DM:DLIST:DATA	0   1, {0   1}   block data		
[SOURCE<[1]>]:BB:DM:DLIST:DATA:APPend	0   1, {0   1}   block data		
[SOURCE<[1]>]:BB:DM:DLIST:DELeTe	<data_list_name>		No query
[SOURCE<[1]>]:BB:DM:DLIST:POINts			
[SOURCE<[1]>]:BB:DM:DLIST:SELeCt	<data_list_name>		
[SOURCE<[1]>]:BB:DM:DLIST:TAG?	<data_list_name>, <tag_name>		Query only
[SOURCE<[1]>]:BB:DM:MLIST:CATlog			Query only
[SOURCE<[1]>]:BB:DM:MLIST:DELeTe	<user_mapping_list_name>		
[SOURCE<[1]>]:BB:DM:MLIST:FREE			Query only
[SOURCE<[1]>]:BB:DM:MLIST:POINts			Query only
[SOURCE<[1]>]:BB:DM:MLIST:SELeCt	<user_mapping_list_name>		
[SOURCE<[1]>]:BB:DM:SETTING:CATalog?			Query only
[SOURCE<[1]>]:BB:DM:SETTING:DELeTe	"setting_file"		No query
[SOURCE<[1]>]:BB:DM:SETTING:LOAD	"setting_file"		No query
[SOURCE<[1]>]:BB:DM:DMSETTING:STORe	"setting_file"		No query
[SOURCE<[1]>]:BB:DM:STANDARD:ULIST:CATalog?			Query only

Command	Parameter	Default unit	Note
[SOURce<[1]>]:BB:DM:STANdard:ULISt:DELeTe	"user_list"		No query
[SOURce<[1]>]:BB:DM:STANdard:ULISt:LOAD	"user_list"		No query
[SOURce<[1]>]:BB:DM:STANdard:ULISt:STORe	"user_list"		No query

**[SOURce<[1]>]:BB:DM:CLISt:CATalog?**

The command queries the control lists present in the default directory. The default directory is set using command `MMEM:CDIRectory`. When the names of the lists are returned they are separated by commas. The command only reads out files with the `*.dm_iqc` extension.

The control lists contain the control signals for digital modulation.

The command is a query command and therefore has no `*RST` value.

**Example:**

```
MMEM:CDIR 'D:/user/dm'
'sets the default directory.
```

```
BB:DM:CLIS:CAT?
'queries which control lists are present in the default directory.
```

```
Response: "c_list1","c_list2","c_list3"
'control lists c_list1, c_list2, and c_list3 are present.
```

*RST value	Resolution	SCPI
-	-	Device-specific

**[SOURce<[1]>]:BB:DM:CLISt:COpy <list name>**

The command copies the selected control list into the control list specified by `<list_name>`. If a control list with the specified name does not yet exist, it is created.

The source file has to be available in the default directory. The default directory is set using command `MMEM:CDIRectory`. A path can be specified, in which case the source file is copied into the file `<list_name>` in the specified directory. The file extension may be omitted. Only files with the file extension `*.dm_iqc` will be copied.

The command triggers an action and therefore has no `*RST` value and no query form.

**Example:**

```
":BB:DM:CLIS:SEL 'c_list1'"
'selects control list c_list1.
```

```
":BB:DM:CLIS:COpy 'c_list4'"
'copies the content of control list c_list1 into control list c_list4. If this list
already exists, its content is overwritten. If the list does not yet exist, it is
created.
```

*RST value	Resolution	SCPI
-	-	Device-specific

[SOURce<[1]]2>:BB:DM:CLIS:DATA 0...255 | block data

The command sends the data to the currently selected control list. If the list already contains data, it is overwritten. This command only writes data into the data section of the file.

The values for the control signals are sent, arranged in a 8-bit value as follows:

Signal	Order	Decimal value of bits
Marker 1	LSBit	1
Marker 2		2
Marker 3		4
Marker 4		8
Burst =		16
LevAtt1		32
CWMod		64
Hop	MSBit	128

The data can also be sent as a binary block, each binary block being a 2-byte value in which the 16 bits represent the binary values (16-bit unsigned integer, 2 bytes, LSByte first). When binary data transmission is in use, command :SYSTem:COMMunicate:GPIB:LTERminator EOI should be used to set the termination character mode to 'EOI control data message only' so that a random LF in the data sequence is not interpreted as End, thereby prematurely terminating the data transmission. The command ...LTER STANdard resets the mode.

For query purposes, the command :FORMat ASCii | PACKed can be used to switch between the formats. The byte sequence is defined in the IEC bus standard as 'most significant byte first'.

\*RST has no effect on data lists. This command is without query.

**Example:**           ":BB:DM:CLIS:SEL 'c\_list1'"  
                          'selects the control list.  
  
                          ":BB:DM:CLIS:DATA 0,0,0,0,8,8,8,0,0,0,0..."  
                          'enters the control values in list c\_list1. In the example, only ramps for marker 4 are set.

*RST value	Resolution	SCPI
-	-	Device-specific

[SOURce<[1]]2>:BB:DM:CLIS:DELeTe <list name>

The command deletes the specified control list from the default directory. The default directory is set using command MMEM:CDIRectory. A path can also be specified, in which case the files in the specified directory are deleted. The file extension may be omitted. Only files with the file extension \*.dm\_iqc will be deleted.

The command triggers an action and therefore has no \*RST value and no query form.

**Example:**           ":BB:DM:CLIS:DEL 'c\_list3'"  
                          'deletes control list c\_list3.

*RST value	Resolution	SCPI
-	-	Device-specific

**[SOURce<[1]>]:BB:DM:CLIS:POINTs?**

The command queries the number of lines (2 bytes) in the currently selected list.

The command is a query command and therefore has no \*RST value.

**Example:**       ":BB:DM:CLIS:SEL "c\_list1""  
                  'selects control list c\_list1.  
  
                  ":BB:DM:CLIS:POIN?"  
                  'queries the number of lines in the control list.

**Response:**     "20"  
                  'the control list consists of 20 lines.

*RST value	Resolution	SCPI
-	-	Device-specific

**[SOURce<[1]>]:BB:DM:CLIS:TAG? <control\_list\_name>, <tag\_name>**

The command queries the content of the specified tag in the selected file.

The command is a query command and therefore has no \*RST value.

**Example:**       ":BB:DM:CLIS:TAG 'c\_list1', 'date'"  
                  'queries the Date tag in control list c\_list1.

**Response:**     "10.10.2003"  
                  'the control list was created on 10.10.2003.

*RST value	Resolution	SCPI
-	-	Device-specific

**[SOURce<[1]>]:BB:DM:CLIS:SELEct <list name>**

The command selects the control list in the default directory. The default directory is set using command `MMEM:CDIRECTory`. A path can also be specified, in which case the files in the specified directory are selected. If a control list with the specified name does not yet exist, it is created. The file extension may be omitted. Only files with the file extension `*.dm_iqc` will be selected or created.

The command triggers an action and therefore has no \*RST value and no query form.

**Example:**       ":BB:DM:CLIS:SEL 'c\_list1'"  
                  'selects control list c\_list1.

*RST value	Resolution	SCPI
-	-	Device-specific

**[SOURCE<[1]|2>]:BB:DM:DLIS:CATalog?**

The command queries the data lists present in the default directory. The default directory is set using command `MMEM:CDIRECTORY`. When the names of the lists are returned they are separated by commas. The command only reads out files with the `*.dm_iqd` extension.

The data lists contain the modulation data for digital modulation.

The command is a query command and therefore has no \*RST value. The numeric suffix on SOURCE<[1]|2> is ignored in this command.

**Example:** `MMEM:CDIR 'D:/user/dm'`  
'sets the default directory.  
  
`:BB:DM:DLIS:CAT?`  
'queries which data lists are present.

**Response:** "d\_list1", "d\_list2", "d\_list3"  
'data lists d\_list1, d\_list2, d\_list3 are present.

*RST value	Resolution	SCPI
-	-	Device-specific

**[SOURCE<[1]|2>]:BB:DM:DLIS:COPY <list name>**

The command copies the selected data list into the data list specified by <list\_name>. If a data list with the specified name already exists, it is overwritten. If it does not yet exist, it is created.

The source file has to be available in the default directory. The default directory is set using command `MMEM:CDIRECTORY`. A path can be specified, in which case the source file is copied into the file <list\_name> in the specified directory. The file extension may be omitted. Only files with the file extension `*.dm_iqc` will be copied.

The command triggers an action and therefore has no \*RST value and no query form.

**Example:** `":BB:DM:DLIS 'd_list1'"`  
'selects data list d\_list1.  
  
`":BB:DM:DLIS:COPY 'd_list2'"`  
'copies the content of data list d\_list1 into data list d\_list2. Any existing content in data list d\_list2 is overwritten.

*RST value	Resolution	SCPI
-	-	Device-specific

[SOURce<[1]|2>]:BB:DM:DLIS:DATA 0 | 1 {,0 | 1 }.| block data

[SOURce<[1]|2>]:BB:DM:DLIS:DATA? [<start>[,<length>]]

The **setting command** sends the bit data to the data list selected with the aid of :BB:DM:DLIS:SELEct. Any existing content in the data list is overwritten. This command only writes data into the data section of the file.

This command sends the bit data to the selected data list, which is overwritten. The data can also be sent as block data in binary or PACKed format (see section Parameters, block data), each byte being interpreted as 8 data bits. In this case, command :SYSTEM:COMMunicate:GPIB:LTERminator EOI should be used to set the termination character mode to 'EOI control data message only' so that a random LF in the data sequence is not interpreted as End, thereby prematurely terminating the data transmission. The command ...LTER STAN resets the mode.

**Example:**  
 ":BB:DM:DLIS:SEL 'dlist1'"  
 'selects data list dlist1. If the file does not yet exist, it is created.  
 ":BB:DM:DLIS:DATA 1,1,1,0,0,0,1,1,0,1..."  
 'sends the specified data to file dlist1. Any data already present is overwritten.

The **query** reads out the data part of the data list. If the query is expanded by using the two parameters <start> and <length>, the list is read out in smaller sections. Start and Length are expressed in bits. Without the parameters the total length is always read out starting from address 1. The command :FORMat ASCii | PACKed can be used to select the data format. The byte sequence is defined in the IEC bus standard (read/write most significant byte first).

**Example:**  
 ":BB:DM:DLIS:SEL 'dlist1'"  
 'selects data list dlist1.  
 "FORM ASCII"  
 'selects ASCII data transmission format.  
 ":BB:DM:DLIS:DATA? 2048,1024"  
 'queries the data starting at bit 2048 for 1024 bits.

\*RST has no effect on data lists.

*RST value	Resolution	SCPI
-	-	Device-specific

[SOURce<[1]|2>]:BB:DM:DLIS:DATA:APPend 0 | 1 {,0 | 1 }.| block data

The command appends the bit data onto the end of the existing data in the selected data list. This means that existing content in the data list is not overwritten. By this means very long data lists can be built up piecemeal. The data format is as specified in command SOURce:BB:DM:DLIS:DATA.

The command cannot be used with an empty data list, such as one that has just been created, for example. In this case the command SOURce:BB:DM:DLIS:DATA must first be used to enter modulation data in the list.

\*RST has no effect on data lists.

**Example 1:**  
 ":BB:DM:DLIS:SEL ' d\_list2'"  
 'selects data list d\_list2.  
 "FORM ASC"  
 'selects ASCII data transmission format.  
 ":BB:DM:DLIS:DATA:APP 1,1,1,0,0,0,1,1,0,1..."  
 'adds the specified numeric data to the existing data in data list d\_list2.

*RST value	Resolution	SCPI
-	-	Device-specific

**[SOURce<[1]2>]:BB:DM:DLIS:DELeT** <list name>

The command deletes the specified data list. from the default directory. The default directory is set using command `MMEM:CDIRectory`. A path can also be specified, in which case the files in the specified directory are deleted. The file extension may be omitted. Only files with the file extension `*.dm_iqd` will be deleted.

The command triggers an action and therefore has no \*RST value and no query form. The numeric suffix on `SOURce<[1]2>` is ignored in this command.

**Example:**       "`:BB:DM:DLIS:DEL ' d_list2'`"  
                  'deletes data list d\_list2.'

*RST value	Resolution	SCPI
-	-	Device-specific

**[SOURce<[1]2>]:BB:DM:DLIS:POIN** <n>

The command defines the number of bits in the selected data list to be utilized. When a list is being filled with block data, this data is only ever sent in multiples of 8 bits. However the exact number of bits to be exploited can be set to a different figure. The superfluous bits in the list are then ignored.

The command triggers an action and therefore has no \*RST value and no query form.

**Example:**       "`:BB:DM:DLIS:POIN 234`"  
                  'defines the number of bits in the data list to be utilized as 234 bits. If the list was filled with block data, at least the last 6 bits will be ignored.'

*RST value	Resolution	SCPI
-	-	Device-specific

**[SOURce<[1]2>]:BB:DM:DLIS:SELeC** <list name>

The command selects the data list in the default directory. The default directory is set using command `MMEM:CDIRectory`. A path can also be specified, in which case the files in the specified directory are selected. If a data list with the specified name does not yet exist, it is created. The file extension may be omitted. Only files with the file extension `*.dm_iqd` will be selected or created.

The modulation data in this data list is used when the data source is selected using the command "`SOURce:BB:DM:SOURce DLIS`".

The command triggers an action and therefore has no \*RST value and no query form.

**Example:**       "`:BB:DM:DLIS:SEL ' d_list2'`"  
                  'selects data list d\_list2.'

*RST value	Resolution	SCPI
-	-	Device-specific

**[SOURce<[1]>]:BB:DM:DLIS:TAG? <control\_list\_name>, <tag\_name>**

The command queries the content of the specified tag in the selected file.

The command is a query command and therefore has no \*RST value.

**Example:**       ":BB:DM:DLIS:TAG 'D\_list1', 'date'  
                  'queries the Date tag in control list D\_list1.

Response:       "10.10.2003"  
                  'the data list was created on 10.10.2003.

*RST value	Resolution	SCPI
-	-	Device-specific

**[SOURce<[1]>]:BB:DM:FLIS:CATalog?**

Queries the user filter files present in the default directory. The default directory is set using command `MMEM:CDIRectory`. When the names of the files are returned they are separated by commas. The command only reads out files with the \*.vaf extension.

The command is a query command and therefore has no \*RST value.

**Example:**       ":BB:DM:FILT:TYPE USER"  
                  'selects the User filter type.  
  
                  "MMEM:CDIR 'D:\Filter\_List'"  
                  'selects the directory for the user-defined filters.  
  
                  ":BB:DM:FLIS:CAT?"  
                  'queries the user-defined filters in the directory.

*RST value	Resolution	SCPI
-	-	Device-specific

**[SOURce<[1]>]:BB:DM:FLIS:DElete <file name>**

Deletes the specified user filter file. The default directory is set using command `MMEM:CDIRectory`. A path can also be specified, in which case the files in the specified directory are read. The file extension may be omitted. Only files with the file extension \*.vaf will be deleted.

**Example:**       ":BB:DM:FILT:TYPE USER"  
                  'selects the User filter type.  
  
                  "MMEM:CDIR 'D:\Filter\_List'"  
                  'selects the directory for the user-defined filters.  
  
                  ":BB:DM:FLIS:DEL user\_filter3"  
                  'deletes the user-defined filter.

*RST value	Resolution	SCPI
-	-	Device-specific



**[SOURCE<[1]>]:BB:DM:FLIST:FREE?**

Queries the user filter free memory.

**Example:**       ":BB:DM:FILT:TYPE USER"  
                  'selects the User filter type.  
  
                  ":BB:DM:FLIS:FREE?"  
                  'queries the free memory.

*RST value	Resolution	SCPI
-	-	Device-specific

**[SOURCE<[1]>]:BB:DM:FLIST:POINTS?**

Queries the user filter list length.

**Example:**       ":BB:DM:FILT:TYPE USER"  
                  'selects the User filter type.  
  
                  ":BB:DM:FLIS:POIN?"  
                  'queries the list length.

*RST value	Resolution	SCPI
-	-	Device-specific

**[SOURCE<[1]>]:BB:DM:FLIST:SElect <file name>**

The command selects the user-defined filter (\*.vaf).

The directory applicable to the following command is defined with the command `MMEMory:CDIR`. To access the files in this directory, only the file name is required, without the path and the file extension.

**Example:**       ":BB:DM:FILT:TYPE USER"  
                  'selects the User filter type.  
  
                  "MMEM:CDIR 'D:\Filter\_List'"  
                  'selects the directory for the user-defined filters.  
  
                  ":BB:DM:FLIS:SEL user\_filter3"  
                  'selects the user-defined filter.

*RST value	Resolution	SCPI
-	-	Device-specific

**[SOURce<[1]>]:BB:DM:MLIS:CATalog?**

Queries the user mapping lists present in the default directory. The default directory is set using command `MMEM:CDIRectory`. When the names of the files are returned they are separated by commas. The command only reads out files with the `*.vam` extension.

The command is a query command and therefore has no `*RST` value.

**Example:**       `" :BB:DM:FORM USER"`  
                   'selects the User modulation type.  
                   `"MMEM:CDIR 'D:\mapping_List'"`  
                   'selects the directory for the user mapping lists.  
                   `" :BB:DM:MLIS:CAT?"`  
                   'queries the user mapping lists in the directory.

*RST value	Resolution	SCPI
-	-	Device-specific

**[SOURce<[1]>]:BB:DM:MLIS:DELeTe <file name>**

Deletes the specified user mapping file. The default directory is set using command `MMEM:CDIRectory`. A path can also be specified, in which case the files in the specified directory are read. The file extension may be omitted. Only files with the file extension `*.vam` will be deleted.

**Example:**       `" :BB:DM:FORM USER"`  
                   'selects the User modulation type.  
                   `"MMEM:CDIR 'D:\mapping_List'"`  
                   'selects the directory for the user mapping lists.  
                   `" :BB:DM:MLIS:DEL user_mapping3"`  
                   'deletes the user mapping list.

*RST value	Resolution	SCPI
-	-	Device-specific

**[SOURce<[1]>]:BB:DM:MLIS:FREE?**

Queries the user modulation mapping list free memory.

**Example:**       `" :BB:DM:FORM USER"`  
                   'selects the User modulation type.  
                   `" :BB:DM:FLIS:FREE?"`  
                   'queries the free memory.

*RST value	Resolution	SCPI
-	-	Device-specific

**[SOURce<[1]|2>]:BB:DM:MLIS:POINTs?**

Queries the user modulation mapping list length.

**Example:**       ":BB:DM:FORM USER"  
                  'selects the User modulation type.  
  
                  ":BB:DM:MLIS:POIN?"  
                  'queries the list length.

*RST value	Resolution	SCPI
-	-	Device-specific

**[SOURce<[1]|2>]:BB:DM:MLIS:SELEct <mapping\_list\_name>**

The command selects the user mapping list in the default directory. The default directory is set using command `MMEM:CDIRECTory`. A path can also be specified, in which case the files in the specified directory are selected. If a user mapping list with the specified name does not yet exist, it is created. The file extension may be omitted. Only files with the file extension `*.vam` will be selected or created.

The command triggers an action and therefore has no \*RST value and no query form.

**Example:**       ":BB:DM:MLIS:SEL 'c\_list1'  
                  'selects the user mapping list c\_list1.

*RST value	Resolution	SCPI
-	-	Device-specific

**[SOURce<[1]|2>]:BB:DM:SETTing:CATalog?**

This command reads out the files with Custom Digital Modulation settings in the default directory. The default directory is set using command `MMEM:CDIRECTory`. Only files with the file extension `*.dm` will be listed.

The command is a query command and therefore has no \*RST value.

**Example:**       MMEM:CDIR 'D:\user\dig\_mod  
                  'sets the default directory to D:\user\dig\_mod.  
  
                  BB:DM:SETT:CAT?  
                  'reads out all the files with Custom Digital Modulation settings in the default directory.  
  
                  Response: "'DM\_1'"  
                  'the file 'DM\_1' with Custom Digital Modulation settings is available.

*RST value	Resolution	SCPI
-	-	Device-specific

**[SOURce<[1]>]:BB:DM:SETTING:DELete <file\_name>**

This command deletes the selected file with Custom Digital Modulation settings. The directory is set using command `MMEM:CDIRectory`. A path can also be specified, in which case the files in the specified directory are read. The file extension may be omitted. Only files with the file extension `*.dm` will be deleted.

This command triggers an event and therefore has no `*RST` value and no query form.

**Example:**           `":BB:DM:STAN:ULIS:DEL 'DM_1'"`  
                           'Deletes file 'DM\_1'.

*RST value	Resolution	SCPI
-	-	Device-specific

**[SOURce<[1]>]:BB:DM:SETTING:LOAD <file\_name>**

This command loads the selected file with Custom Digital Modulation settings. The directory is set using command `MMEM:CDIRectory`. A path can also be specified, in which case the files in the specified directory are read. The file extension may be omitted. Only files with the file extension `*.dm` will be loaded.

This command triggers an event and therefore has no `*RST` value and no query form.

**Example:**           `":BB:DM:STAN:ULIS:LOAD 'DM_1'"`  
                           'loads file 'DM\_1'.

*RST value	Resolution	SCPI
-	-	Device-specific

**[SOURce<[1]>]:BB:DM:SETTING:STORE <file\_name>**

This command stores the current Custom Digital Modulation settings into the selected file. The directory is set using command `MMEM:CDIRectory`. A path can also be specified, in which case the files in the specified directory are read. Only the file name has to be entered. User Standards are stored as files with the specific file extensions `*.dm`.

This command triggers an event and therefore has no `*RST` value and no query form.

**Example:**           `":BB:DM:STAN:ULIS:STOR 'DM_QAM'"`  
                           'stores the current Custom Digital Modulation settings into file 'DM\_QAM'.

*RST value	Resolution	SCPI
-	-	Device-specific

**[SOURce<[1]>]:BB:DM:STANDARD:ULIST:CATalog?**

This command reads out the files with Digital Standard settings in the default directory. The default directory is set using command `MMEM:CDIRectory`. Only files with the file extension `*.dm_stu` will be listed.

The command is a query command and therefore has no `*RST` value.

**Example:**           `"MMEM:CDIR 'D:\user\dig_mod'"`  
                           'sets the default directory to D:\user\dig\_mod.  
                           `":BB:DM:STAN:ULIS:CAT?"`  
                           'reads out all the files with Digital Standard settings in the default directory.

Response: "'DM\_QAM'"  
 'the file 'DM\_QAM' with Digital Standard settings is available.

*RST value	Resolution	SCPI
-	-	Device-specific

**[SOURce<[1]>]:BB:DM:STANDARD:ULIST:DELETE <file\_name>**

This command deletes the selected file with Digital Standard settings. The directory is set using command `MMEM:CDIRECTORY`. A path can also be specified, in which case the files in the specified directory are read. The file extension may be omitted. Only files with the file extension `*.dm_stu` will be deleted.

This command triggers an event and therefore has no \*RST value and no query form.

**Example:**       "`:BB:DM:STAN:ULIS:DEL 'DM_QAM' "`  
                   '`deletes file 'DM_QAM'.`'

*RST value	Resolution	SCPI
-	-	Device-specific

**[SOURce<[1]>]:BB:DM:STANDARD:ULIST:LOAD <file\_name>**

This command loads the selected file with Digital Standard settings. The directory is set using command `MMEM:CDIRECTORY`. A path can also be specified, in which case the files in the specified directory are read. The file extension may be omitted. Only files with the file extension `*.dm_stu` will be loaded.

This command triggers an event and therefore has no \*RST value and no query form.

**Example:**       "`:BB:DM:STAN:ULIS:LOAD 'DM_QAM' "`  
                   '`loads file 'DM_QAM'.`'

*RST value	Resolution	SCPI
-	-	Device-specific

**[SOURce<[1]>]:BB:DM:STANDARD:ULIST:STORE <file\_name>**

This command stores the current Digital Standard settings into the selected file. The directory is set using command `MMEM:CDIRECTORY`. A path can also be specified, in which case the files in the specified directory are read. Only the file name has to be entered. User Standards are stored as files with the specific file extensions `*.dm_stu`.

This command triggers an event and therefore has no \*RST value and no query form.

**Example:**       "`:BB:DM:STAN:ULIS:STOR 'DM_QAM' "`  
                   '`stores the current Digital Standard settings into file 'DM_QAM'.`'

*RST value	Resolution	SCPI
-	-	Device-specific

# SOURce-BB-IMPairment Subsystem

This subsystem contains the commands for the digital I/Q impairments. Included in this section is also the description of command `SOURce:BB:IQOutput:SOURce` that determined the source for the I/Q output connectors.

Digital I/Q impairments can be activated in the case of two-path instruments with a second R&S Baseband Main Module and one of the R&S Baseband Generators, R&S External Baseband Input (if available) or R&S Noise Generator.

`SOURce[1]` = Path A

`SOURce2` = Path B

Command	Parameters	Default unit	Remark
<code>[SOURce&lt;[1] 2&gt;:]BB:IMPairment:IQRatio</code>	-1 dB ... +1 dB	dB	
<code>[SOURce&lt;[1] 2&gt;:]BB:IMPairment:LEAKage:I</code>	0 ... 50.0 PCT	PCT	
<code>[SOURce&lt;[1] 2&gt;:]BB:IMPairment:LEAKage:Q</code>	0 ... 50.0 PCT	PCT	
<code>[SOURce&lt;[1] 2&gt;:]BB:IMPairment:OPTimization:MODE</code>	FAST   QHIGH		
<code>[SOURce&lt;[1] 2&gt;:]BB:IMPairment:OPTimization:STATe</code>	ON   OFF		
<code>[SOURce&lt;[1] 2&gt;:]BB:IMPairment:QUADrature[:ANGLE]</code>	-10.0...10.0 DEG	DEG	
<code>[SOURce&lt;[1] 2&gt;:]BB:IMPairment:STATe</code>	ON   OFF		
<code>[SOURce&lt;[1] 2&gt;:]BB:IQGain</code>	AUTO   DBM3   DB0   DB3   DB6		
<code>[SOURce:]BB:IQOutput:SOURce</code>	A   B		

## `[SOURce<[1]|2>:]BB:IMPairment:IQRatio` -1 dB ... +1 dB

This command sets the ratio of I modulation to Q modulation (amplification “imbalance”). The input may be either in dB or %. The resolution is 0.001 dB, an input in percent is rounded to the closest valid value in dB. A query returns the value in dB.

**Examples:** `"BB:IMP:IQR 3 PCT"`  
 'sets the imbalance to 3 percent.

`"BB:IMP:IQR?"`  
 'queries the imbalance.

Response: `"0.259000"`  
 'the value is returned in dB

`"BB:IMP:IQR 1"`  
 'sets the imbalance to 1 dB.

*RST value	Resolution	SCPI
0 dB	0.001 dB	Device-specific

**[SOURce<[1]>:]BB:IMPairment:LEAKage:I -10 ... 10 PCT**

This command sets the carrier leakage amplitude for the I-signal component.

**Example:** "BB:IMP:LEAK:I 3 PCT"  
'sets the leakage for the I-component to 3 percent.

*RST value	Resolution	SCPI
0 PCT	0.05 PCT	Device-specific

**[SOURce<[1]>:]BB:IMPairment:LEAKage:Q -10 ... 10 PCT**

This command sets the carrier leakage amplitude for the Q-signal component.

**Example:** "BB:IMP:LEAK:Q 3 PCT"  
'sets the leakage for the Q-component to 3 percent.

*RST value	Resolution	SCPI
0 PCT	0.05 PCT	Device-specific

**[SOURce<[1]>:]BB:IMPairment:OPTimization:MODE FAST | QHIGH**

This command sets the optimization mode.

**Parameters:** **FAST**  
Optimization is reached by compensation for I/Q skew.

**QHIGh**  
Optimization is reached by compensation for I/Q skew and frequency response correction.

**Example:** "BB:IMP:OPT:MODE FAST"  
'sets the optimization mode Fast.

*RST value	Resolution	SCPI
FAST	-	Device-specific

**[SOURce<[1]>:]BB:IMPairment:OPTimization:STATE ON | OFF**

This command activates and deactivates internal compensation of signal distortions by the I/Q modulator.

**Example:** "BB:IMP:OPT:STAT ON"  
'activates internal compensation of signal distortions.

*RST value	Resolution	SCPI
OFF	-	Device-specific

**[SOURce<[1]>:]BB:IMPairment:QUADrature[:ANGLE] -10.0 ... 10.0 DEG**

This command sets the quadrature offset for the digital I/Q signal.

**Example:** "BB:IMP:QUAD:ANGL -5DEG"  
'sets the quadrature offset to -5 degrees.

*RST value	Resolution	SCPI
0 DEG	0.02 DEG	Device-specific

[SOURce<[1]|2>:]BB:IMPairment:STATe ON | OFF

The command activates (ON) and deactivates (OFF) the three impairment or correction values LEAKage, QUADrature and IQRatio for the digital baseband signal prior to input into the I/Q modulator.

**Example:** "BB:IMP:STAT OFF"  
'deactivates digital impairment.

*RST value	Resolution	SCPI
OFF	-	Device-specific

[SOURce<[1]|2>:]BB:IQGain AUTO | DBM3 | DB0 | DB3 | DB6

This command specifies the baseband gain for the internal or (in case of two-path instruments, external) baseband signal.

Thus, the modulation of the I/Q modulator can be optimized for any measurement requirement. The gain settings for an external analog wideband signal (**Analog Wideband I/Q In**) are performed with command :SOURce:IQ:GAIN

**Parameters:** **AUTO**  
Activates automatic setting. The modulation is automatically optimized for the internally set baseband signal.

**DBM3**  
Activates 0 dB gain. With this setting, signal distortions are minimized.

**DB0**  
Activates 0 dB gain (standard settings).

**DB3**  
Activates 0 dB gain.

**DB6**  
Activates 0 dB gain. With this setting, signal noise is minimized.

**Example:** "IQ:SOUR BAS"  
'selects the internal baseband signal as the input signal of the I/Q modulator.  
"BB:IQG DB6"  
'sets gain 6dB (best for low noise).

*RST value	Resolution	SCPI
Auto	0.01 dB	Device-specific



## SOURce:CORRection Subsystem

The output level is corrected in the CORRection subsystem. Correction is performed by user-defined table values being added to the output level for the respective RF frequency. In the R&S Vector Signal Generator, this subsystem is used to select, transfer and activate user correction tables.

Each list is stored as a file. The name of the user correction file can be freely selected. The file extension \*.uco is assigned automatically and cannot be changed.

The files can be stored in a freely selectable directory and opened from there. The default directory is set using command `MMEMory:CDIRectory`. In the case of files which are stored in the default directory, only the file name has to be specified in commands. Otherwise, the complete absolute path has to be specified with every command. The extension can be omitted in any case.

The amplitude can also be linearized automatically by means of a R&S NRP power sensor connected to the generator output signal. With the aid of the `SOURce:CORRection:CSET:DATA:POWER:SONCe` command, a list with correction values for external test assemblies can be automatically determined, e.g. for compensating the frequency response of cables. The correction values can be acquired any time irrespective of the modulation settings of the generator.

Multi level measurements allow to take into account the changing VSWR for the different attenuator settings (`SOURce:CORRection:CSET:DATA:POWER:MLEVel`).

---

### Note

*In the following command examples, the files are stored in the default directory.*

---

In the case of two-path instruments with two RF paths, level correction is performed separately for the two RF outputs. The commands which affect selection and activation of the tables are therefore path-specific. The suffix under `SOURce` distinguishes the outputs:

`SOURce[1]` = RF output A

`SOURce2` = RF output B

The keyword `SOURce` is optional with commands for RF output A and can be omitted. For RF output B, the command must contain the keyword together with the suffix 2.

For one path instruments, the keyword `SOURce` is optional and can be omitted.

For two-path instruments, the same tables are, however, accessed for both paths. File operations such as creating, deleting and querying files are therefore path-independent. In this case, the suffix under `SOURce` must be omitted. An error message is displayed if the suffix is specified.

Command	Parameters	Default unit	Remark
<code>[SOURce:]CORRection:CSET:CATalog?</code>	-		Query only
<code>[SOURce:]CORRection:CSET:DATA:FREQuency</code>	300 kHz...RF <sub>max</sub> {,300 kHz...RF <sub>max</sub> }	HZ	
<code>[SOURce:]CORRection:CSET:DATA:FREQuency:POINts?</code>			Query only
<code>[SOURce:]CORRection:CSET:DATA:POWer</code>	-40 dB...6dB {,-40 dB...6 dB}	dB	
<code>[SOURce:]CORRection:CSET:DATA:POWer:POINts?</code>			Query only
<code>[[:SOURce&lt;[1] 2&gt;:]CORRection:CSET:POWer:MLEVel&lt;[1]...9&gt;</code>			Query only
<code>[[:SOURce&lt;[1] 2&gt;:]CORRection:CSET:POWer:MLEVel:STATe</code>	ON   OFF		No query
<code>[[:SOURce&lt;[1] 2&gt;:]CORRection:CSET:DATA[:SENSor&lt;[1] 2 3&gt;]:POWer]:SONCe</code>			No query
<code>[SOURce:]CORRection:CSET:DELeTe</code>	<table name>		No query
<code>[SOURce&lt;[1] 2&gt;:]CORRection:CSET[:SELeCt]</code>	<table name>		

Command	Parameters	Default unit	Remark
[SOURce<[1]>:]CORRection:DEXChange:AFILe:CATalog?			Query only
[SOURce<[1]>:]CORRection:DEXChange:AFILe:EXTension	TXT   CSV		
[SOURce<[1]>:]CORRection:DEXChange:AFILe:SELEct	<ASCII file name>		
[SOURce<[1]>:]CORRection:DEXChange:AFILe:SEParator:C OLumn	TABulator   SEMicolon   COMMa   SPACe		
[SOURce<[1]>:]CORRection:DEXChange:AFILe:SEParator:D ECimal	DOT   COMMa		
[SOURce<[1]>:]CORRection:DEXChange:EXECute			No query
[SOURce<[1]>:]CORRection:DEXChange:MODE	IMPort   EXPort		
[SOURce<[1]>:]CORRection:DEXChange:SELEct	<list mode file>		
[SOURce<[1]>:]CORRection:MLEVel:STATe	ON   OFF		
[SOURce<[1]>:]CORRection[:]STATe]	ON   OFF		
[SOURce<[1]>:]CORRection:VALue		dB	Query only

**[SOURce:]CORRection:CSET:CATalog?**

The command requests a list of user correction tables. The individual lists are separated by commas.

The lists are stored with the fixed file extensions \*.uco in a directory of the user's choice. The directory applicable to the commands is defined with the command MMEMoRY:CDIR.

This command is a query command and has no \*RST value. The numerical suffix at SOURce must not be used for this command.

**Example:** "MMEM:CDIR 'D:\Lists\ucor'"  
'selects the directory for the user correction files.

"CORR:CSET:CAT?"  
'queries which correction tables are available.

Response: "UCOR1,UCOR2,UCOR3"  
'the correction tables UCOR1,UCOR2 and UCOR3 are available.

*RST value	Resolution	SCPI
-	-	Device-specific

**[SOURce:]CORRection:CSET:DATA:FREQuency** 300 kHz...RF<sub>max</sub> {, 300 kHz...RF<sub>max</sub>}, (RF<sub>max</sub> depending on model)

The command transfers the frequency data to the table selected with :CORRection:CSET:SELEct.

\*RST does not affect data lists. The numerical suffix at SOURce must not be used for this command.

**Example:** "CORR:CSET 'D:\Lists\ucor\ucor1'"  
'selects the table ucor1.  
"CORR:CSET:DATA:FREQ 100MHz,102MHz,103MHz,..."  
'enters the frequency value in the table UCOR1.

*RST value	Resolution	SCPI
-	-	Device-specific

**[SOURce:]CORRection:CSET:DATA:FREQuency:POINts?**

The command queries the number of frequency values in the selected table.

The command is a query command and therefore has no \*RST value. The numerical suffix at SOURce must not be used for this command.

**Example:** "CORR:CSET 'D:\Lists\ucor\ucor1'"  
 'selects the table ucor1.  
 "CORR:CSET:DATA:FREQ:POIN?"  
 'queries the number of frequency values in the table ucor1.  
 Response: "440"  
 'the table ucor1 contains 440 frequency values.

*RST value	Resolution	SCPI
-	-	Device-specific

**[SOURce:]CORRection:CSET:DATA:POWer -40dB ... 6dB {,-40dB ... 6dB}**

The command transfers the level data to the table selected with :CORRection:CSET:SElect.

\*RST does not affect data lists. The numerical suffix at SOURce must not be used for this command.

**Example:** "CORR:CSET 'D:\Lists\ucor\ucor1'"  
 'selects the table ucor1.  
 "CORR:CSET:DATA:POW 1dB, 0.8dB, 0.75dB,..."  
 'enters the level values in the table ucor1.

*RST value	Resolution	SCPI
-	-	Device-specific

**[SOURce:]CORRection:CSET:DATA:POWer:POINts?**

The command queries the number of level values in the selected table.

The command is a query command and therefore has no \*RST value. The numerical suffix at SOURce must not be used for this command.

**Example:** "CORR:CSET 'D:\Lists\ucor\ucor1'"  
 'selects the table ucor1.  
 "CORR:CSET:DATA:POW:POIN?"  
 'queries the number of level values in the table ucor1.  
 Response: "440"  
 'the table ucor1 contains 440 level values.

*RST value	Resolution	SCPI
-	-	Device-specific

[SOURce:]CORRection:CSET:DATA:POWer:MLEVel<[1]...9>

The command queries the measurement results of a multi channel measurement: The values of each column of the user correction list are queried separately, i.e. the correction values for a specific attenuator setting. Numeric suffix 1 denotes the high power measurement, suffixes 2 to 9 the different attenuator settings starting at 0 dB up to 35 dB in 5 dB steps.

The command is a query command and therefore has no \*RST value.

**Example:** SOUR:CORR:CSET:DATA:POW:MLEV4?  
'queries the level correction values for attenuator setting 10 dB.

*RST value	Resolution	Options	SCPI
OFF	-	-	-

[SOURce:]CORRection:CSET:DATA:POWer:MLEVel:STATe ON | OFF

The command activates the acquisition of multi level data with a connected power sensor. Separate measurements are made for the different attenuator ranges up to 40 dB. Thus, the changes in VSWR for the different ranges are taken into account, the level accuracy increases. For ranges from 40 dB on the changes in VSWR are negligible. The reference level is set internally and cannot be controlled by the user. The measurement results are entered into additional columns of the User Correction list. The Multi Level Correction measurements are made in addition to a Single Level Correction measurement. When the user correction list is activated, it is possible to select which of the measurements is to be used for level correction (command SOUR:CORR:MLEV:STAT ON).

**Example:** SOUR:CORR:CSET:DATA:POW:MLEV:STAT ON  
'activates the acquisition of multi level data with a connected power sensor.

*RST value	Resolution	Options	SCPI
OFF	-	-	-

[SOURce<[1]2>:]CORRection:CSET:DATA[:SENSor<[1]2[3]>][:POWer]:SONCe

The command activates the filling of the user correction list with level values acquired by the power sensor.

The command activates the filling of the user correction list with level values acquired by the selected power sensor. All level correction values for the given frequency values are entered in the selected list. The power sensor used is selected by the suffix in key word SENSE of the command header. Suffix 1 denotes the sensor connected to the SENSOR connector, suffix 2 the sensor connected first to one of the USB interfaces and suffix 3 the sensor connected second to one of the USB interfaces.

The command is an event and therefore has no \*RST value and no query.

**Example:** "CORR:CSET:DATA:SENS:POW:SONC"  
'fills the user correction list with level values acquired by the power sensor connector to the SENSOR connector.

*RST value	Resolution	SCPI
-	-	Device-specific

**[SOURce:]CORRection:CSET:DELeTe <table name>**

The command deletes the specified table.

The lists are stored with the fixed file extensions \*.uco in a directory of the user's choice. The directory applicable to the commands is defined with the command MMEMory:CDIR. A path can also be specified in command :SOUR:CORR:CSET:CAT?, in which case the file in the specified directory is deleted.

The command is an event and therefore has no \*RST value. The numerical suffix under SOURce is irrelevant.

**Example:**           "MMEM:CDIR 'D:\Lists\ucor'"  
                           'selects the directory for the user correction files.  
                           "CORR:CSET:DEL 'UCOR1'"  
                           'deletes the table ucor1.

*RST value	Resolution	SCPI
-	-	Device-specific

**[SOURce<[1]2>:]CORRection:DEXChange:AFILe:CATalog?**

The command requests a list of available ASCII files for export/import of user correction data. The individual files are separated by commas.

The ASCII files are stored with the fixed file extensions \*.txt or \*.csv in a directory of the user's choice. The directory applicable to the commands is defined with the command MMEMory:CDIR.

The command is a query command and therefore has no \*RST value.

**Example:**           MMEM:CDIR 'd:\lists\ucor/import'  
                           'selects the directory for the ASCII files with frequency and level value pairs.  
                           CORR:DEXC:AFIL:EXT TXT  
                           'selects that ASCII files with extension \*.txt are listed.  
                           CORR:DEXC:AFIL:CAT?  
                           'queries the available files with extension \*.txt.  
                           Response: 'ucor1,ucor2'  
                           'the ASCII files ucor1.txt and ucor2.txt are available.

*RST value	Resolution	SCPI
-	-	Device-specific

**[SOURce<[1]2>:]CORRection:DEXChange:AFILe:EXTension TXT | CSV**

The command selects the file extension of the ASCII file to be imported or exported. Selection TXT (text file) or CSV (Excel file) is available.

**Example:**           MMEM:CDIR 'd:\lists\ucor/import'  
                           'selects the directory for the ASCII files with frequency and level value pairs.  
                           CORR:DEXC:AFIL:EXT TXT  
                           'selects that ASCII files with extension \*.txt are listed.  
                           CORR:DEXC:AFIL:CAT?  
                           'queries the available files with extension \*.txt.  
                           Response: 'list1,list2'  
                           'the ASCII files ucor1.txt and ucor2.txt are available.

*RST value	Resolution	SCPI
TXT	-	Device-specific

**[SOURce<[1]>:]CORRection:DEXChange:AFILe:SElect** <ascii\_file\_name>

The command selects the ASCII file to be imported or exported.

The ASCII files are stored with the fixed file extensions \*.txt or \*.csv in a directory of the user's choice. The directory applicable to the commands is defined with the command MMEMory:CDIR. A path can also be specified in command SOUR:CORR:DEXC:AFIL:SEL, in which case the files are stored or loaded in the specified directory.

**Example:**           CORR:DEXC:MODE IMP  
                       'selects that ASCII files with frequency and level value pairs are imported and transferred into user correction lists.  
                       CORR:DEXC:AFIL:SEL 'D:/user/ucor/import/ucor.csv'  
                       'selects that ASCII file ucor.csv is imported.  
                       CORR:DEXC:SEL 'D:/user/ucor/import/ucor\_imp'  
                       'selects that the ASCII file ucor.csv is imported into user correction list ucor\_imp.

*RST value	Resolution	SCPI
-	-	Device-specific

**[SOURce<[1]>:]CORRection:DEXChange:AFILe:SEParator:COLumn** TABulator | SEMicolon | COMMa | SPACe

The command selects the separator between the frequency and level column of the ASCII table.

**Example:**           CORR:DEXC:MODE EXP  
                       'selects that the user correction list is exported into an ASCII file.  
                       CORR:DEXC:AFIL:SEL 'D:/user/ucor/import/ucor.csv'  
                       'selects ASCII file ucor.csv as destination for the user correction list data.  
                       CORR:DEXC:AFIL:SEP:COL TAB  
                       'the pairs of frequency and level values are separated by a tabulator.  
                       CORR:DEXC:AFIL:SEP:DEC DOT  
                       'selects the decimal separator dot.  
                       CORR:DEXC:SEL 'D:/user/ucor/import/ucor\_imp'  
                       'selects that the user correction list ucor\_imp is imported into ASCII file ucor.csv.

*RST value	Resolution	SCPI
SEMIColon	-	Device-specific

**[SOURCE<[1]>:]CORREction:DEXChange:AFIL:SEParator:DECimal DOT | COMMa**

The command the decimal separator used in the ASCII data between '.' (decimal point) and ',' (comma) with floating-point numerals.

**Example:**       CORR:DEXC:MODE EXP  
                   'selects that the user correction list is exported into an ASCII file.

                  CORR:DEXC:AFIL:SEL 'D:/user/ucor/import/ucor.csv'  
                   'selects ASCII file ucor.csv as destination for the user correction list data.

                  CORR:DEXC:AFIL:SEP:COL TAB  
                   'the pairs of frequency and level values are separated by a tabulator.

                  CORR:DEXC:AFIL:SEP:DEC DOT  
                   'selects the decimal separator dot.

                  CORR:DEXC:SEL 'D:/user/ucor/import/ucor\_imp'  
                   'selects that the user correction list ucor\_imp is imported into ASCII file ucor.csv.

*RST value	Resolution	SCPI
DOT	-	Device-specific

**[SOURCE<[1]>:]CORREction:DEXChange:EXECute**

The command starts the export or import of the selected file. When import is selected, the ASCII file is imported as user correction list. When export is selected, the user correction list is exported into the selected ASCII file.

The command triggers an event and therefore has no \*RST value.

**Example:**       CORR:DEXC:MODE IMP  
                   'selects that ASCII files with frequency and level value pairs are imported and transferred into user correction lists.

                  CORR:DEXC:AFIL:SEL 'D:/user/ucor/import/ucor.csv'  
                   'selects that ASCII file ucor.csv is imported.

                  CORR:DEXC:SEL 'D:/user/ucor/import/ucor\_imp'  
                   'selects that the ASCII file ucor.csv is imported into user correction list ucor\_imp.

                  CORR:DEXC:EXEC  
                   'starts the import of the ASCII file data into the user correction file.

*RST value	Resolution	SCPI
-	-	Device-specific

**[SOURce<[1]|2>:]CORRection:DEXChange:MODE IMPort | EXPort**

The command selects if user correction lists should be imported or exported. Depending on the selection her, the file select command define either the source or the destination for user correction lists and ASCII files.

**Example:**  
 CORR:DEXC:MODE IMP  
 'selects that ASCII files with frequency and level value pairs are imported and transferred into user correction lists.  
 CORR:DEXC:AFIL:SEL 'D:/user/ucor/import/ucor.csv'  
 'selects that ASCII file ucor.csv is imported.  
 CORR:DEXC:SEL 'D:/user/ucor/import/ucor\_imp'  
 'selects that the ASCII file ucor.csv is imported into user correction list ucor\_imp.

*RST value	Resolution	SCPI
-	-	Device-specific

**[SOURce<[1]|2>:]CORRection:DEXChange:SElect <list\_name>**

The command selects the user correction list to be imported or exported.

The user correction files are stored with the fixed file extensions \*.uco in a directory of the user's choice. The directory applicable to the commands is defined with the command MMEMoRY:CDIR. A path can also be specified in command SOUR:CORR:DEXC:SEL, in which case the files are stored or loaded in the specified directory.

**Example:**  
 CORR:DEXC:MODE IMP  
 'selects that ASCII files with frequency and level value pairs are imported and transferred into user correction lists.  
 CORR:DEXC:AFIL:SEL 'D:/user/ucor/import/ucor.csv'  
 'selects that ASCII file ucor.csv is imported.  
 CORR:DEXC:SEL 'D:/user/ucor/import/ucor\_imp'  
 'selects that the ASCII file ucor.csv is imported into user correction list ucor\_imp.

*RST value	Resolution	SCPI
-	-	Device-specific

**[SOURce<[1]|2>:]CORRection:CSET[:SElect] <table name>**

The command selects the table for user correction. Level correction must also be activated with the command SOURce<[1]|2>:CORRection:CSET:STATE ON.

The lists are stored with the fixed file extensions \*.uco in a directory of the user's choice. The directory applicable to the commands is defined with the command MMEMoRY:CDIR. A path can also be specified in command :SOUR:CORR:CSET:SEL, in which case the files in the specified directory are selected.

The command is an event and therefore has no \*RST value.

**Example:**  
 "CORR:CSET 'D:\Lists\ucor\ucor1'"  
 'selects the table ucor1 for RF output A.  
 "CORR ON"  
 'activates level correction for RF output A. Correction is performed using the table ucor1.

*RST value	Resolution	SCPI
-	-	Device-specific



**[SOURce:]CORRection:MLEV:STATe** ON | OFF

The command activates the use of multi level data for user correction. The setting is only available for user correction list with multi level correction data (see command SOUR:CORR:CSET:DATA:POW:MLEV:STAT ON).

**Example:** SOUR:CORR:MLEV:STAT ON  
'activates the use of multi level correction data for user correction.

*RST value	Resolution	SCPI
-	-	Device-specific

**[SOURce<[1]|2>:]CORRection[:STATe]** ON | OFF

The command activates/deactivates level correction. Level correction is performed using the table which has been selected with the command CORRection:CSET:SElect.

**Example:** "SOUR2:CORR:CSET 'ucor1"  
'selects the table ucor1 for RF output B.  
"SOUR2:CORR ON"  
'activates user correction for RF output B.

*RST value	Resolution	SCPI
OFF	-	Device-specific

**[SOURce:]CORRection:VALue?**

The command requests the current value for user correction.

This command is a query command and has no \*RST value.

**Example:** "CORR:VAL?"  
'queries the value currently used for level correction.  
Response: "-3"  
'the correction value is - 3dB.

*RST value	Resolution	SCPI
-	-	Device-specific

## SOURce:FM Subsystem

The FM subsystem contains the commands for checking the frequency modulation. The settings for the internal modulation source (LF generator) are made in the SOURce:LFOuTput subsystem.

Frequency modulation requires option R&S SMJ-B20 (FM/PhiM Modulator).

For one-path instruments, the keyword SOURce is optional and can be omitted.

Command	Parameters	Default unit	Remark
[SOURce<[1]]2>:]FM[:DEVIation]	0 Hz...10 MHz	Hz	
[SOURce<[1]]2>:]FM:EXTErnal:COUPling	AC   DC		
[SOURce<[1]]2>:]FM:MODE	NORMal		
[SOURce<[1]]2>:]FM:SENSitivity?			Query only
[SOURce<[1]]2>:]FM:SOURce	EXT   INT   INT, EXT		
[SOURce<[1]]2>:]FM:STATe	ON   OFF		

### [SOURce<[1]]2>:]FM[:DEVIation] 0 Hz ... 10 MHz

The command sets the modulation deviation of the frequency modulation in Hz. The maximal deviation depends on the RF frequency set and the selected modulation mode (see data sheet).

**Example:** "FM 5E3"  
'sets the FM modulation deviation to 5 kHz.

*RST value	Resolution	SCPI
10 kHz	See data sheet	Compliant

### [SOURce<[1]]2>:]FM:EXTErnal:COUPling AC | DC

The command selects the coupling mode for the external modulation input (EXT MOD) in the case of frequency modulation.

**Note:**

*Coupling for external feed via input EXT MOD can be set independently for modulations AM, FM and PhiM.*

**Parameters:** **AC**  
The DC voltage component is disconnected from the modulation signal.

**DC**  
The modulation signal is not changed.

**Example:** "FM:EXT:COUP AC"  
'selects the coupling mode AC for external frequency modulation.

*RST value	Resolution	SCPI
AC	-	Compliant

**[SOURce<[1]]2>:FM:MODE NORMal**

The command selects the mode for the frequency modulation.

**Parameters:**       **NORMal**

The maximum range for modulation bandwidth and FM deviation is available.

**Example:**       "FM:MODE NORM"

'selects Normal mode for external frequency modulation.

*RST value	Resolution	SCPI
NORMal	-	Compliant

**[SOURce<[1]]2>:FM:SENSitivity?**

The command queries the input sensitivity of the EXT MOD input in Hz/V. The command is only effective if the external modulation source is selected (SOUR:FM:SOUR EXT). The returned value depends on the modulation deviation setting (SOUR:FM:DEVIation). This value is assigned to the voltage value for full modulation of the input signal.

The command is a query command and therefore has no \*RST value.

**Example:**       "FM:DEV 5E3"

'sets a modulation deviation of 5 kHz.

"FM:SENS?"

'queries the input sensitivity at the EXT MOD input.

Response: "5E3"

'since the voltage value for full modulation is 1V, the resulting sensitivity is precisely 5000Hz/V.

*RST value	Resolution	SCPI
-	-	Compliant

**[SOURce<[1]]2>:FM:SOURce EXT | INT | INT,EXT**

The command selects the modulation source for frequency modulation. INT is the LF generator. The frequency of the internal modulation signal can be set in the SOURce:LFOuTput subsystem. The external signal is input at the EXT MOD connector. Internal and external modulation source can be selected at the same time.

**Example:**       "FM:SOUR INT"

'selects the internal modulation source.

*RST value	Resolution	SCPI
INTernal	-	Compliant

**[SOURce<[1]]2>:FM:STATe ON | OFF**

The command activates/deactivates frequency modulation.

Activation of frequency modulation deactivates phase modulation.

**Example:**       "FM:STAT ON"

'activates FM modulation.

*RST value	Resolution	Correlation	SCPI
OFF	-	FM ON deactivates phase modulation.	Compliant

## SOURce:FREQUENCY Subsystem

This subsystem contains the commands used to define the frequency settings for the RF sources and sweeps.

In the case of two-path instruments with two RF paths, the numerical suffix under SOURce distinguishes between RF output A and RF output B:

SOURce[1] = RF output A

SOURce2 = RF output B

The keyword SOURce is optional with commands for RF output A and can be omitted. For RF output B, the command must contain the keyword together with the suffix 2.

In case of one-path instruments, the keyword SOURce is optional and can be omitted.

Command	Parameters	Default unit	Remark
[SOURce<[1] 2>:]FREQUENCY:CENTer	300 kHz...RF <sub>max</sub>	Hz	RF <sub>max</sub> depending on model
[SOURce<[1] 2>:]FREQUENCY[:CW]:FIXed]	300 kHz...RF <sub>max</sub>	Hz	RF <sub>max</sub> depending on model
[SOURce:]FREQUENCY[:CW]:FIXed]:RCL	INCLude   EXCLude		
[SOURce<[1] 2>:]FREQUENCY:MANual	300 kHz...RF <sub>max</sub>	Hz	RF <sub>max</sub> depending on model
[SOURce<[1] 2>:]FREQUENCY:MODE	CW FIXed   SWEEp   LIST		
[SOURce<[1] 2>:]FREQUENCY:OFFSet	50 ...+50 GHz	Hz	
[SOURce<[1] 2>:]FREQUENCY:PHASe:CONTInuous:STATe	ON  OFF		
[SOURce<[1] 2>:]FREQUENCY:SPAN	0...RF <sub>max</sub>	Hz	RF <sub>max</sub> depending on model
[SOURce<[1] 2>:]FREQUENCY:STARt	300 kHz...RF <sub>max</sub>	Hz	RF <sub>max</sub> depending on model
[SOURce<[1] 2>:]FREQUENCY:STOP	300 kHz...RF <sub>max</sub>	Hz	RF <sub>max</sub> depending on model
[SOURce<[1] 2>:]FREQUENCY:STEP[:INCRement]	0...RF <sub>max</sub> - 100 kHz	Hz	
[SOURce<[1] 2>:]FREQUENCY:STEP:MODE	USER   DECimal		

### [SOURce<[1]|2>:]FREQUENCY:CENTer 300 kHz...RF<sub>max</sub> (RF<sub>max</sub> depending on model)

The command sets the center frequency of the sweep. This setting in combination with the span setting ([SOURce:]FREQUENCY:SPAN) defines the sweep range.

This command is linked to the commands [SOURce:]FREQUENCY:STARt and [SOURce:]FREQUENCY:STOP, i.e. changing these values causes the CENTer value to change, and vice versa:

$$CENTer = (STARt + STOP)/2.$$

As with the **Frequency** value entered in the header, the OFFSet value is also taken into consideration with this command. The specified value range is therefore only effective if OFFSet is set to 0. The value range for other OFFSet values can be calculated using the following formula.

$$300 \text{ kHz} + OFFSet \dots RF_{max} + OFFSet$$

**Example:** "FREQ:CENT 400 MHz"  
 'sets the center frequency for the frequency sweep to 400 MHz.  
 "FREQ:SPAN 200 MHz"  
 'sets a span of 200 MHz. This sets the sweep range to 300 MHz to 500 MHz.

*RST value	Resolution	Correlation	SCPI
300 MHz	0.01 Hz	CENTEr = (STARt + STOP)/2	Compliant

**[SOURce<[1]|2>:FREQuency[:CW]:FIXed] 300 kHz ... RF<sub>max</sub>**

The command sets the frequency of the RF output signal for CW mode (SOURce:FREQuency:MODE CW). In Sweep mode (SOURce:FREQuency:MODE SWEep), this value is linked to the current sweep frequency.

In addition to a numerical value, it is also possible to specify UP and DOWN. The frequency is then increased or decreased by the value which is set under [SOURce<[1]|2>:FREQuency:STEP.

As with the FREQ value entered in the display, the OFFSet value is also taken into consideration with this command. The specified value range is therefore only effective if OFFSet is set to 0. The value range for other OFFSet values can be calculated using the following formula:

$$300 \text{ kHz} + \text{OFFSet} \dots \text{RF}_{\text{max}} + \text{OFFSet}$$

**Example:** "FREQ 500kHz"  
 'sets the frequency of RF output signal A to 500 kHz.

*RST value	Resolution	Correlation	SCPI
1 GHz	0.01 Hz	:FREQ for FREQ:MODE SWE linked to sweep frequency.	Compliant

**[SOURce:]FREQuency[:CW]:FIXed]:RCL INCLude | EXCLude**

The command determines whether the current frequency setting is retained or whether the stored frequency setting is adopted when an instrument configuration is loaded.

\*RST does not affect this setting. In case of two-path instruments, the setting is valid for both paths. If a suffix is specified, it is ignored.

**Parameters:** **INCLude**  
 The stored frequency is also loaded when a stored instrument configuration is loaded.

**EXCLude**  
 The RF frequency is not loaded when a stored instrument configuration is loaded. The current frequency is retained.

**Example:** "FREQ:RCL INCL"  
 'the stored frequency is set if the Recall command is called.

*RST value	Resolution	SCPI
-	-	Compliant

[SOURce<[1]|2>:]FREQuency:MANual START ... STOP

In Sweep mode (:SOUR:FREQ:MODE SWE) the command sets the frequency for the next sweep step in the **Step** sweep mode (SOUR:SWE:MODE MAN). Here only frequency values between the settings [SOUR]:FREQ:STAR and . . . :STOP are permitted. Each sweep step is triggered by a separate SOUR:FREQ:MAN command.

As with the **Frequency** value entered in the header, the OFFSet value is also taken into consideration with this command. The specified value range is therefore only effective if OFFSet is set to 0. The value range for other OFFset values can be calculated using the following formula.

START + OFFSet ... STOP +OFFSet

**Example:** "SWE:MODE MAN"  
 'sets the **Step** sweep mode.  
 "FREQ:MAN 500MHz"  
 'sets an RF frequency of 500 MHz for the next step in the **Step** sweep mode.  
 "FREQ:MODE SWE"  
 'sets the Frequency Sweep mode. An RF frequency of 500 MHz is output.  
 "FREQ:MAN 550MHz"  
 'triggers the next sweep step with an RF frequency of 550 MHz.

*RST value	Resolution	SCPI
100 MHz	0.01 Hz	Compliant

[SOURce<[1]|2>:]FREQuency:MODE CW|FIXed | SWEep | LIST

The command sets the instrument operating mode and therefore also the commands used to set the output frequency.

**Parameters:** **CW|FIXed**  
 The instrument operates in fixed-frequency mode, in case of two-path instruments, for the selected path. CW and FIXed are synonyms. The output frequency is set with :SOURce:FREQuency:CW|FIXed.

**SWEep**  
 The instrument operates in SWEep mode, in case of two-path instruments, for the selected path. The frequency is set using the commands SOURce:FREQuency:STARt; STOP; CENTer; SPAN; MANual.

**LIST**  
 The instrument processes a list of frequency and level settings for the selected path (in case of two-path instruments). The List mode settings are made in the SOURce:LIST subsystem. The setting SOURce:FREQuency:MODE LIST also sets the command SOURce:POWer:MODE automatically to LIST.

**Example:** "FREQ:MODE SWE"  
 'sets the SWEep mode. The settings under SOURce:FREQuency:STARt; STOP; CENTer; SPAN; MANual become effective.

*RST value	Resolution	Correlation	SCPI
CW	-	FREQ:MODE LIST sets POW:MODE LIST	Compliant

**[SOURce<[1]|2>:FREQuency:OFFSet** -50 GHz ... + 50 GHz

The command sets the frequency offset of a downstream instrument, e.g. a mixer. If a frequency offset is entered, the frequency entered with `SOURce:FREQuency:...` no longer corresponds to the RF output frequency. The following correlation applies:

`SOURce:FREQuency:...` = RF output frequency + `SOURce:FREQuency:OFFSet`.

Entering an offset does not change the RF output frequency, but rather the query value of `SOURce:FREQuency:.....`

**Example:**           `FREQ:OFFS 500kHz`  
                          'sets the frequency offset to 500 kHz.

*RST value	Resolution	SCPI
0 Hz	0.01 Hz	Compliant

**[SOURce<[1]|2>:FREQuency:PHASe:CONTInuous:STATe** ON | OFF

Activates/deactivates phase continuous frequency settings. For a given RF frequency setting, phase continuous frequency changes are possible in a limited frequency range (see also Chapter 4, Section "[Phase Continuous Frequency Setting](#)").

The output sinewave is phase continuous, i.e there will be no phase discontinuity or glitch when changing the frequency.

**Example:**           `FREQ:PHAS:CONT:STAT ON`  
                          'activates phase continuous mode

*RST value	Resolution	SCPI
OFF	-	Device-specific

**[SOURce<[1]|2>:FREQuency:SPAN** 0...RF<sub>max</sub> (RF<sub>max</sub> depending on model)

This command specifies the span for the sweep. This setting in combination with the center frequency setting (`[SOUR]:FREQ:CENT`) defines the sweep range.

This command is linked to the commands `[SOUR]:FREQ:STAR` and `[ :SOUR]:FREQ:STOP`, i.e. changing these values causes the `SPAN` value to change, and vice versa:

$$\text{SPAN} = (\text{STOP} - \text{START})$$

Negative values for `SPAN` are permitted; `START > STOP` then applies.

**Example:**           `"FREQ:CENT 400 MHz"`  
                          'sets the center frequency of the frequency sweep to 400 MHz.  
                          `"FREQ:SPAN 200 MHz"`  
                          'sets a span of 200 MHz. This sets the sweep range to 300 MHz to 500 MHz.

*RST value	Resolution	Correlation	SCPI
400 MHz	0.01 Hz	$\text{SPAN} = (\text{STOP} - \text{START})$	Compliant

**[SOURCE<[1]]2>:FREQUENCY:START** 300 kHz...RF<sub>max</sub> (RF<sub>max</sub> depending on model)

This command sets the start frequency for the sweep mode. START can be greater than STOP.

This command is linked to the commands [SOURCE]:FREQ:CENT and [SOURCE]:FREQ:SPAN, i.e. changing these values causes the START value to change, and vice versa:

$$START = (CENTER - SPAN/2).$$

As with the **Frequency** value entered in the header, the OFFSet value is also taken into consideration with this command. The specified value range is therefore only effective if OFFSet is set to 0. The value range for other OFFSet values can be calculated using the following formula:

$$300 \text{ kHz} + OFFSet \dots RF_{max} + OFFSet$$

**Example:** "FREQ:START 1 MHz"  
'sets the start frequency for the frequency sweep to 1 MHz.  
"FREQ:STOP 2 GHz"  
'sets the stop frequency for the frequency sweep to 2 GHz.

*RST value	Resolution	Correlation	SCPI
100 MHz	0.01 Hz	START = (CENTER - SPAN/2)	Compliant

**[SOURCE<[1]]2>:FREQUENCY:STOP** 300 kHz...RF<sub>max</sub> (RF<sub>max</sub> depending on model)

This command sets the stop frequency for the sweep mode. STOP can be less than START.

This command is linked to the commands [:SOURCE]:FREQ:CENT and [:SOURCE]:FREQ:SPAN, i.e. changing these values causes the START value to change, and vice versa:

$$STOP = (CENTER + SPAN/2).$$

As with the **Frequency** value entered in the header, the OFFSet value is also taken into consideration with this command. The specified value range is therefore only effective if OFFSet is set to 0. The value range for other OFFSet values can be calculated using the following formula:

$$300 \text{ kHz} + OFFSet \dots RF_{max} + OFFSet$$

**Example:** "FREQ:STOP 2 GHz"  
'sets the stop frequency for the frequency sweep to 2 GHz.  
"FREQ:STAR 1 MHz"  
'sets the start frequency for the frequency sweep to 1 MHz.

*RST value	Resolution	Correlation	SCPI
500 MHz	0.01 Hz	STOP = (CENTER + SPAN/2)	Compliant

**[SOURCE<[1]]2>:FREQUENCY:STEP[:INCRement]** 0 Hz ... RF<sub>max</sub> - 100 kHz

The command sets the step width for the frequency setting if the frequency values UP/DOWN are used and variation mode SOUR:FREQ:STEP:MODE USER is selected. The command is linked to **Variation Step** for manual control, i.e. the command also sets the step width of the rotary knob for **Variation Active on**. In the case of two-path instruments, the step width can be set separately for each path.

**Example:** "FREQ:STEP 50 kHz"  
'sets the step width for the frequency setting to 50 kHz.

*RST value	Resolution	SCPI
1 MHz	0.01 Hz	Device-specific



[SOURce<[1]|2>:]FREQuency:STEP:MODE USER | DECimal

This command activates (USER) or deactivates (DECimal) the user-defined step width used when varying the frequency value with the frequency values UP/DOWN. The command is linked to the command **Variation Active** for manual control, i.e. the command also activates/deactivates the user-defined step width used when varying the frequency value with the rotary knob. In the case of two-path instruments, the step width can be set separately for each path.

**Example:**            "FREQ:STEP 50 kHz"  
                               'sets the step width for the frequency setting to 50 kHz.

                              "FREQ:STEP:MODE USER"  
                               'actives this step width for frequency variation with the rotary knob (manual control) and with frequency values UP/DOWN (remote control).

*RST value	Resolution	SCPI
DECimal	-	Device-specific

## SOURce:LFOutput Subsystem

This subsystem contains the commands for setting the LF signal source in CW and Sweep mode as well as for analog modulation. An LF generator is always available in the instrument, also in two-path instruments.

An LF sweep is set in several steps which are shown in the following example:

1. Set the sweep range.

```
LFOutput:FREQuency:START 4 kHz
LFOutput:FREQuency:STOP 10 kHz
```

2. Select linear or logarithmic sweep spacing.

```
LFOutput:SWEep[:FREQuency]:SPACing LIN
```

3. Set the step width and dwell time.

```
LFOutput:SWEep[:FREQuency]:STEP[:LINear] 100 Hz
LFOutput:SWEep[:FREQuency]:DWELl 20 ms
```

4. Determine the sweep mode.

```
LFOutput:SWEep:MODE AUTO
```

5. Determine the trigger.

```
TRIGger0:SOURce SINGLE
```

6. Activate the sweep.

```
LFOutput:FREQuency:MODE SWEep
```

7. Trigger the sweep (depending on the mode).

```
LFOutput:SWEep:EXECute
```

The keyword **SOURce** is optional and can be omitted. An error message is displayed if a suffix is specified.

Command	Parameters	Default unit	Remark
[SOURce:]LFOutput:FREQuency	0.1 Hz...1 MHz	Hz	
[SOURce:]LFOutput:FREQuency:MANual	0.1 Hz...1 MHz	Hz	
[SOURce:]LFOutput:FREQuency:MODE	CW FIXed   SWEep		
[SOURce:]LFOutput:FREQuency:START	0.1 Hz...1 MHz	Hz	
[SOURce:]LFOutput:FREQuency:STOP	0.1 Hz...1 MHz	Hz	
[SOURce:]LFOutput[:STATe]	ON   OFF		
[SOURce:]LFOutput:SWEep[:FREQuency]:DWELl	2 ms ... 10 s	s	
[SOURce:]LFOutput:SWEep[:FREQuency]:EXECute	-		
[SOURce:]LFOutput:SWEep[:FREQuency]:MODE	AUTO   MANual   STEP		
[SOURce:]LFOutput:SWEep[:FREQuency]:POINTs	<numeric_value>		
[SOURce:]LFOutput:SWEep[:FREQuency]:SHAPE	SAWTooth   TRIangle		
[SOURce:]LFOutput:SWEep[:FREQuency]:SPACing	LINear   LOGarithmic		
[SOURce:]LFOutput:SWEep[:FREQuency]:STEP[:LINear]	0 ... (STOP - START)	Hz	
[SOURce:]LFOutput:SWEep[:FREQuency]:STEP:LOGarithmic	0.01 ... 50 PCT	PCT	
[SOURce:]LFOutput:VOLTage	0 V ... 4 V	V	

**[SOURce:]LFOuTput:FREQuency 0.1 Hz... 1 MHz**

The command sets the frequency of the LF signal for CW mode (:SOUR:MODE CW mode). The setting is valid for all analog modulations (AM/FM/PhiM/Pulse) with internal modulation source.

In Sweep mode (SOUR:LFO:FREQ:MODE SWE), the frequency is linked to the sweep frequency.

**Example:** "LFO:FREQ 5kHz"  
'sets the frequency of the LF signal to 5 kHz.

*RST value	Resolution	Correlation	SCPI
1 kHz	0.1 Hz	LFO:FREQ for LFO:FREQ:MODE SWE linked to sweep frequency	Compliant

**[SOURce:]LFOuTput:FREQuency:MANual START ... STOP**

In Sweep mode (SOUR:LFO:FREQ:MODE SWE) the command sets the frequency for the next sweep step in the **Step** sweep mode (SOUR:LFO:SWE:MODE MAN). Here only frequency values between the settings SOUR:LFO:FREQ:STAR and . . . :STOP are permitted. Each sweep step is triggered by a separate SOUR:LFO:FREQ:MAN command.

**Example:** "LFO:SWE:MODE MAN"  
'sets the **Step** sweep mode.

"LFO:FREQ:MAN 5 kHz"  
'sets an LF frequency of 5 kHz for the next step in the **Step** sweep mode.

"LFO:FREQ:MODE SWE"  
'sets the LF Sweep mode. An LF frequency of 5 kHz is output.

"LFO:FREQ:MAN 5.1 kHz"  
'triggers the next sweep step with a frequency of 5.1 kHz.

*RST value	Resolution	SCPI
1 kHz	0.1 Hz.	Compliant

**[SOURce:]LFOuTput:FREQuency:MODE CW|FIXed | SWEep**

The command sets the instrument operating mode and therefore also the commands used to set the output frequency.

**Parameters: CW|FIXed**  
The instrument operates in fixed-frequency mode. CW and FIXed are synonyms. The output frequency is set with [SOURce:]LFOuTput:FREQuency.

**SWEep**  
The instrument operates in SWEep mode. The frequency is set using the commands SOURce:LFOuTput:FREQuency:STARt; STOP or MANual.

**Example:** "LFO:FREQ:MODE SWE"  
'sets the SWEep mode. The settings under SOURce:LFOuTput:FREQuency:STARt; STOP; MANual become effective.

*RST value	Resolution	SCPI
CW	-	Compliant

**[SOURce:]LFOOutput:FREQUENCY:START** 0.1 Hz... 1 MHz

This command sets the start frequency for the LF Sweep mode.

**Example:** "RST\*" 'activates all presets.  
 "LFO:SWE:MODE AUTO" 'sets the AUTO sweep mode, i.e. each trigger triggers a complete sweep.  
 "TRIG0:SOUR SING" 'sets the SINGle trigger mode, i.e. the sweep is triggered by the command :LFOOutput:SWEep:EXECute or \*TRG.  
 "LFO:FREQ:STAR 100 kHz" 'sets the start frequency for the LF sweep to 100 kHz.  
 "LFO:FREQ:STOP 200 kHz" 'sets the stop frequency of the LF sweep to 200 kHz.  
 "LFO:FREQ:MODE SWE" 'sets the LF sweep mode.  
 "LFO:SWE:EXEC" 'a one-off LF sweep from 100 kHz to 200 kHz is performed. The linear step width is 1 kHz with a dwell time of 15 ms (preset values).

*RST value	Resolution	SCPI
1 kHz	0.1 Hz	Compliant

**[SOURce:]LFOOutput:FREQUENCY:STOP** 0.1 Hz... 1 MHz

This command sets the stop frequency for the LF sweep.

**Example:** "LFO:FREQ:STOP 200 kHz" 'sets the stop frequency for the LF sweep to 200 kHz.  
 "LFO:FREQ:STAR 100 kHz" 'sets the start frequency for the LF sweep to 100 kHz.

*RST value	Resolution	SCPI
50 kHz	0.1 Hz	Compliant

**[SOURce:]LFOOutput[:STATE]** ON | OFF

The command activates/deactivates the LF output.

**Example:** "LFO ON" 'activates the LF output. The settings under LFO:FREQ and LFO:SWE become effective.

*RST value	Resolution	SCPI
OFF	-	Device-specific

**[SOURCE:]LFOuTput:SWEep[:FREQuency]:DWELl 2 ms...10 s**

The command sets the dwell time for each frequency step of the sweep.

**Example:** "LFO:SWE:DWEL 20 ms"  
'sets a dwell time of 20 ms.'

*RST value	Resolution	SCPI
10 ms	0.1 ms	Device-specific

**[SOURCE:]LFOuTput:SWEep[:FREQuency]:EXECute**

The command immediately starts an LF sweep. The MODE setting determines which sweep is executed, e.g. SOURCE:LFOuTput:SWEep:FREQuency:MODE STEP. The command corresponds to the manual-control command EXECUTE SINGLE SWEEP.

This command triggers an event and therefore has no \*RST value.

**Example:** "LFO:SWE:MODE STEP"  
'sets the step-by-step processing of the LF sweep.'  
  
"LFO:SWE:EXEC"  
'starts a step of the LF sweep.'

*RST value	Resolution	SCPI
-	-	Device-specific

**[SOURCE:]LFOuTput:SWEep[:FREQuency]:MODE AUTO | MANuAl | STEP**

The command sets the cycle mode of the LF sweep.

The assignment of the IEC/IEEE-bus commands to the sweep modes is given in the description of the sweep menus.

**Parameters:** **AUTO**  
Each trigger triggers exactly one complete sweep.

**MANuAl**

The trigger system is not active. Each frequency step of the sweep is triggered individually, either by varying the **Current Frequency** value using the rotary knob under manual control or by means of a :LFOuTput:FREQ:MAN command under remote control. With manual control, the frequency increases or decreases (depending on the direction of the rotary encoder) by the value specified under :LFOuTput:FREQ:STEP:INCRement. With remote control, the frequency is set directly with the command :LFOuTput:FREQ:MAN.

**STEP**

Each trigger triggers one sweep step only. The frequency increases by the value entered under [SOURCE:]LFOuTput:SWEep:STEP.

**Example:** "LFO:SWE:MODE AUTO"  
'selects **Mode Auto**.'

*RST value	Resolution	SCPI
AUTO	-	Device-specific

**[SOURCE:]LFOuTput:SWEep[:FREQuency]:POINts <numeric\_value>**

The command sets the number of steps in an LF sweep. The command is linked to the command :LFOuTput:SWEep[:FREQuency]:STEP as follows:

The following applies for linear sweeps and START < STOP:  $POINts = ((STOP-START) / STEP:LIN) + 1$

The following applies for logarithmic sweeps and START < STOP:  
 $POINts = ((\log STOP - \log START) / \log STEP:LOG) + 1$

If POINts changes, the value of STEP is adjusted. The START and STOP value is retained.

Two separate POINts values are used for linear or logarithmic sweep spacing (LFOuTput:SWEep[:FREQuency]:SPACing LIN | LOG). The command is always effective for the currently set sweep spacing.

**Example:** "LFO:FREQ:STAR"  
 'sets the start frequency to 2 kHz.  
 "LFO:FREQ:STOP"  
 'sets the stop frequency to 20 kHz.  
 "LFO:SWE:SPAC LIN"  
 'sets linear sweep spacing.  
 "LFO:SWE:POIN 11"  
 'sets 11 sweep steps for linear sweep spacing. The sweep step width (STEP) is automatically set to 2 kHz.

*RST value	Resolution	Correlation	SCPI
100	1	The value of :LFO:SWE:STEP is adjusted automatically.	Device-specific (adapted to instrument properties)

**[SOURCE:]LFOuTput:SWEep[:FREQuency]:SHAPE SAWTooth | TRiangle**

The command sets the cycle mode for a sweep sequence (shape).

**Parameters: SAWTooth**  
 One sweep runs from start to stop frequency. Each subsequent sweep starts at the start frequency, i.e. the shape of the sweep sequence resembles a sawtooth.

**TRiangle**  
 One sweep runs from start to stop frequency and back, i.e. the shape of the sweep resembles a triangle. Each subsequent sweep starts at the start frequency.

**Example:** SOUR:LFO:SWE:SHAP TRI  
 'selects the sweep cycle with alternating ascending and descending sweep directions.

*RST value	Resolution	Options	SCPI
SAWTooth	-		Device-specific

**[SOURCE:]LFOOutput:SWEep[:FREQUENCY]:SPACing LINear | LOGarithmic**

The command selects linear or logarithmic sweep spacing.

**Example:** "LFO:SWE:SPAC LIN"  
'selects linear sweep spacing.

*RST value	Resolution	SCPI
LINear	-	Device-specific

**[SOURCE:]LFOOutput:SWEep[:FREQUENCY]:STEP[:LINear] 0 ... (STOP - START)**

The command sets the step width for the linear sweep.

This command is linked to the command :LFOOutput:SWEep[:FREQUENCY]:POINTs as follows:

The following applies for START < STOP: POINTs = (((STOP-START) / STEP:LIN) + 1

If STEP:LIN changes, the value of POINTs is adjusted. The START and STOP value is retained.

**Example:** "LFO:FREQ:STAR"  
'sets the start frequency to 2 kHz.  
"LFO:FREQ:STOP"  
'sets the stop frequency to 20 kHz.  
"LFO:SWE:SPAC LIN"  
'sets linear sweep spacing.  
"LFO:SWE:STEP 2 kHz"  
'sets the sweep step width to 2 kHz. The number of sweep steps for linear sweep spacing (POINTs) is automatically set to 11.

*RST value	Resolution	Correlation	SCPI
1kHz	0.1 Hz	The value of :LFO:SWE:POIN is adjusted automatically.	Device-specific

**[SOURCE:]LFOOutput:SWEep[:FREQUENCY]:STEP:LOGarithmic 0.01 ... 100 PCT**

The command specifies the step width factor for logarithmic sweeps. The next frequency value of a sweep is calculated (for START < STOP) using the following formula:

$$\text{New frequency} = \text{Old frequency} + \text{STEP:LOG} \times \text{Old frequency}$$

STEP:LOG therefore gives the fraction of the old frequency. The frequency is increased by this fraction for the next sweep step. Usually STEP:LOG is given in percent, whereby the suffix PCT must always be used.

The command is linked to the command :LFOOutput:SWEep[:FREQUENCY]:POINTs as follows:

The following applies for logarithmic sweeps and START < STOP:

$$\text{POINTs} = ((\log \text{STOP} - \log \text{START}) / \log \text{STEP:LOG}) + 1$$

If STEP:LOG changes, the value of POINTs is adjusted. The START and STOP value is retained.

**Example:** "LFO:FREQ:STAR"  
 'sets the start frequency to 1 kHz.

"LFO:FREQ:STOP"  
 'sets the stop frequency to 100 kHz.

"LFO:SWE:SPAC LOG"  
 'sets logarithmic sweep spacing.

"LFO:SWE:STEP:LOG 10PCT"  
 'sets the step width for logarithmic sweep spacing to 10% of the previous frequency in each instance.

*RST value	Resolution	Correlation	SCPI
1 PCT	0.01 PCT	The value of :LFO:SWE:POIN is adjusted automatically.	Device-specific

**[SOURce:]LFOutput:VOLTage 0 V..4 V**

The command sets the output voltage of the LF output.

**Example:** "LFO:VOLT 3 V"  
 'sets the voltage of the LF output to 3 V.

*RST value	Resolution	SCPI
1 V	0.001 V	Device-specific



## SOURce:LIST Subsystem

This subsystem contains the commands for the List mode of the instrument.

The following settings are required to operate the instrument in List mode:

1. Create a list.

If a list which does not exist is selected with the `:LIST:SEL` command, an empty list with the name of the selected list is created.

```
SOURce1:LIST:SEL "New_list"
```

2. Fill the list with values.

All list components must be of the same length. This does not apply to components of length 1.

This is interpreted as if the component has the same length as the other components and as if all values are the same as the first value.

```
SOURce1:LIST:FREQ 100 MHz, 110 MHz, 120 MHz, ...
```

```
SOURce1:LIST:POW 2dBm, -1dBm, 0dBm, ...
```

3. Select a list.

If a new empty file has been created with the `:LIST:SEL` command, this file is selected, otherwise an existing list must be selected before the List mode is activated.

```
SOURce1:LIST:SEL "Old_list"
```

4. Set the dwell time.

The dwell time determines the duration of the individual list steps.

```
SOURce1:LIST:DWELL 3ms
```

5. Set the List mode.

The List mode determines the way in which the list is processed.

In the example the list is processed once only or repeatedly depending on the trigger setting.

```
SOURce1:LIST:MODE AUTO
```

6. Determine the trigger.

In the example each trigger causes the list to be processed once from beginning to end.

```
SOURce:LIST:TRIGger:SOURce SINGLE
```

7. Activate the List mode.

```
SOURce1:FREQuency:MODE LIST
```

8. Trigger the list (depending on the mode).

```
SOURce1:LIST:TRIGger:EXECute
```

9. Deactivate the List mode.

```
SOURce1:FREQuency:MODE CW
```

---

### Note:

*SCPI refers to the individual lists as segments.*

---

In the case of two-path instruments with two RF paths, the List mode is activated and set separately for the two RF outputs. The commands which affect selection and activated of the lists are therefore path-specific. The suffix under `SOURce` distinguishes the outputs:

`SOURce[1]` = RF output A

`SOURce2` = RF output B

The keyword SOURce is optional with commands for RF output A and can be omitted. For RF output B, the command must contain the keyword together with the suffix 2.

For one-path instruments, the keyword SOURce is optional and can be omitted.

The same lists are, however, accessed for both paths. File operations such as creating, deleting and querying lists are therefore path-independent. In this case, the suffix under SOURce must be omitted. An error message is displayed if the suffix is specified.

Command	Parameters	Default unit	Remark
[SOURce<[1] 2>:]LIST:CATalog?			Query only
[SOURce<[1] 2>:]LIST:DELeTe	<list name>		
[SOURce<[1] 2>:]LIST:DELeTe:ALL			
[SOURce<[1] 2>:]LIST:DEXChange:AFILe:CATalog?			Query only
[SOURce<[1] 2>:]LIST:DEXChange:AFILe:EX Tension	TXT   CSV		
[SOURce<[1] 2>:]LIST:DEXChange:AFILe:SE Lect	<ASCII file name>		
[SOURce<[1] 2>:]LIST:DEXChange:AFILe:SE Parator:COLumn	TABulator   SEMicolon   COMMa   SPACE		
[SOURce<[1] 2>:]LIST:DEXChange:AFILe:SE Parator:DECimal	DOT   COMMa		
[SOURce<[1] 2>:]LIST:DEXChange:EXECute			No query
[SOURce<[1] 2>:]LIST:DEXChange:MODE	IMPort   EXPort		
[SOURce<[1] 2>:]LIST:DEXChange:SELeCt	<list mode file>		
[SOURce<[1] 2>:]LIST:DWELl	1 ms ... 1 s	s	
[SOURce<[1] 2>:]LIST:FREQUency	300kHz..RF <sub>max</sub> {, 300kHz..RF <sub>max</sub> }   block data	Hz	RF <sub>max</sub> depending on model
[SOURce<[1] 2>:]LIST:FREQUency:POINts?			Query only
[SOURce<[1] 2>:]LIST:INDex:STARt	0 ... list length		
[SOURce<[1] 2>:]LIST:INDex:STOP	0 ... list length		
[SOURce<[1] 2>:]LIST:LEARn			No query
[SOURce<[1] 2>:]LIST:MODE	AUTO   STEP		
[SOURce<[1] 2>:]LIST:POWer	-145 ... 30 dBm {, -145 ... 30 dBm}   block data	dBm	
[SOURce<[1] 2>:]LIST:POWer:POINts?			Query only
[SOURce<[1] 2>:]LIST:RESet			No query
[SOURce<[1] 2>:]LIST:SELeCT	<list name>		
[SOURce<[1] 2>:]LIST:TRIGger:EXECute			No query
[SOURce<[1] 2>:]LIST:TRIGger:SOURce	AUTO IMMediate   SINGle BUS   EXTeRnal		

**[SOURce<[1]>:]LIST:CATalog?**

The command requests a list of available lists. The individual lists are separated by commas.

The lists are stored with the fixed file extensions **\*.lsw** in a directory of the user's choice. The directory applicable to the commands is defined with the command `MMEMoRY:CDIR`.

The command is a query command and therefore has no **\*RST** value.

**Example:**       `"MMEM:CDIR 'D:\Lists\Listmode'"`  
                   'selects the directory for the list mode files.

`"LIST:CAT?"`  
                   'queries the available lists.

                  Response: 'list1,list2'  
                   'the lists list1 and list2 are available.

*RST value	Resolution	SCPI
-	-	Device-specific

**[SOURce<[1]>:]LIST:DELeTe '<list file name>'**

The command deletes the specified list.

The files are stored with the fixed file extensions **\*.lsw** in a directory of the user's choice. The directory applicable to the command is defined with the command `MMEMoRY:CDIR`. To access the files in this directory, only the file name has to be given, without the path and the file extension. A path can also be specified in command `:SOUR:LIST:CAT?`, in which case the file in the specified directory is deleted.

**\*RST** does not affect data lists.

**Example:**       `"MMEM:CDIR 'D:\Lists\Listmode'"`  
                   'selects the directory for the list mode files.

`"LIST:DEL 'LIST1'"`  
                   'deletes the list list1.

*RST value	Resolution	SCPI
-	-	Device-specific

**[SOURce<[1]>:]LIST:DELeTe:ALL**

The command deletes all lists in the set directory. The List mode must be deactivated beforehand to ensure that no lists are selected when this command is called (`SOUR:FREQ:MODE CW` or `SWE`).

The files are stored with the fixed file extensions **\*.lsw** in a directory of the user's choice. The directory applicable to the command is defined with the command `MMEMoRY:CDIR`. A path can also be specified in command `SOUR:LIST:CAT?`, in which case all list mode files in the specified directory are deleted.

**\*RST** does not affect data lists.

**Example:**       `"MMEM:CDIR 'D:\Lists\Listmode'"`  
                   'selects the directory for the list mode files.

`"FREQ:MODE SWE"`  
                   'deactivates the List mode for RF output and activates the Sweep mode.

`"SOUR2:FREQ:MODE SWE"`  
                   'deactivates the List mode for RF output and activates Sweep mode.

"LIST:DEL:ALL"  
 'deletes all list mode files available in the set directory.

*RST value	Resolution	SCPI
-	-	Device-specific

**[SOURce<[1]|2>:]LIST:DEXChange:AFILe:CATalog?**

The command requests a list of available ASCII files for export/import of list mode data. The individual files are separated by commas.

The ASCII files are stored with the fixed file extensions \*.txt or \*.csv in a directory of the user's choice. The directory applicable to the commands is defined with the command MMEMoRY:CDIR.

The command is a query command and therefore has no \*RST value.

**Example:** MMEM:CDIR 'd:\lists\listmode/import'  
 'selects the directory for the ASCII files with frequency and level value pairs.

LIST:DEXC:AFIL:EXT TXT  
 'selects that ASCII files with extension \*.txt are listed.

LIST:DEXC:AFIL:CAT?  
 'queries the available files with extension \*.txt.

Response: 'list1,list2'  
 'the ASCII files list1.txt and list2.txt are available.

*RST value	Resolution	SCPI
-	-	Device-specific

**[SOURce<[1]|2>:]LIST:DEXChange:AFILe:EXTension TXT | CSV**

The command selects the file extension of the ASCII file to be imported or exported. Selection TXT (text file) or CSV (Excel file) is available.

**Example:** MMEM:CDIR 'd:\lists\listmode/import'  
 'selects the directory for the ASCII files with frequency and level value pairs.

LIST:DEXC:AFIL:EXT TXT  
 'selects that ASCII files with extension \*.txt are listed.

LIST:DEXC:AFIL:CAT?  
 'queries the available files with extension \*.txt.

Response: 'list1,list2'  
 'the ASCII files list1.txt and list2.txt are available.

*RST value	Resolution	SCPI
TXT	-	Device-specific

**[SOURce<[1]>:]LIST:DEXChange:AFILe:SELEct <ascii\_file\_name>**

The command selects the ASCII file to be imported or exported.

The ASCII files are stored with the fixed file extensions \*.txt or \*.csv in a directory of the user's choice. The directory applicable to the commands is defined with the command MMEMory:CDIR. A path can also be specified in command SOUR:LIST:DEXC:AFIL:SEL, in which case the files are stored or loaded in the specified directory.

**Example:** LIST:DEXC:MODE IMP  
 'selects that ASCII files with frequency and level value pairs are imported and transferred into list mode lists.  
 LIST:DEXC:AFIL:SEL 'd:/user/listmode/import/list.csv'  
 'selects that ASCII file list.csv is imported.  
 LIST:DEXC:SEL 'd:/user/listmode/import/list\_imp'  
 'selects that the ASCII file list.csv is imported into list mode list list\_imp.

*RST value	Resolution	SCPI
-	-	Device-specific

**[SOURce<[1]>:]LIST:DEXChange:AFILe:SEParator:COLumn TABulator | SEMicolon | COMMa | SPACe**

The command selects the separator between the frequency and level column of the ASCII table.

**Example:** LIST:DEXC:MODE EXP  
 'selects that the list mode list is exported into an ASCII file.  
 LIST:DEXC:AFIL:SEL 'd:/user/listmode/import/list.csv'  
 'selects ASCII file list.csv as destination for the list mode list data.  
 LIST:DEXC:AFIL:SEP:COL TAB  
 'the pairs of frequency and level values are separated by a tabulator.  
 LIST:DEXC:AFIL:SEP:DEC DOT  
 'selects the decimal separator dot.  
 LIST:DEXC:SEL 'd:/user/listmode/import/list\_imp'  
 'selects that the list mode list list\_imp is imported into ASCII file list.csv.

*RST value	Resolution	SCPI
SEMIColon	-	Device-specific

**[SOURce<[1]>:]LIST:DEXChange:AFILe:SEParator:DECimal DOT | COMMa**

The command the decimal separator used in the ASCII data between '.' (decimal point) and ',' (comma) with floating-point numerals.

**Example:** LIST:DEXC:MODE EXP  
 'selects that the list mode list is exported into an ASCII file.  
 LIST:DEXC:AFIL:SEL 'd:/user/listmode/import/list.csv'  
 'selects ASCII file list.csv as destination for the list mode list data.  
 LIST:DEXC:AFIL:SEP:COL TAB  
 'the pairs of frequency and level values are separated by a tabulator.  
 LIST:DEXC:AFIL:SEP:DEC DOT  
 'selects the decimal separator dot.

```
LIST:DEXC:SEL 'd:/user/listmode/import/list_imp'
'selects that the list mode list list_imp is imported into ASCII file list.csv.
```

*RST value	Resolution	SCPI
DOT	-	Device-specific

**[SOURce<[1]|2>:]LIST:DEXChange:EXECute**

The command starts the export or import of the selected file. When import is selected, the ASCII file is imported as list mode list. When export is selected, the list mode list is exported into the selected ASCII file.

The command triggers an event and therefore has no \*RST value.

**Example:** LIST:DEXC:MODE IMP  
'selects that ASCII files with frequency and level value pairs are imported and transferred into list mode lists.

```
LIST:DEXC:AFIL:SEL 'd:/user/listmode/import/list.csv'
'selects that ASCII file list.csv is imported.
```

```
LIST:DEXC:SEL 'd:/user/listmode/import/list_imp'
'selects that the ASCII file list.csv is imported into list mode list list_imp.
```

```
LIST:DEXC:EXEC
'starts the import of the ASCII file data into the list mode file.
```

*RST value	Resolution	SCPI
-	-	Device-specific

**[SOURce<[1]|2>:]LIST:DEXChange:MODE IMPort | EXPort**

The command selects if list mode lists should be imported or exported. Depending on the selection her, the file select command define either the source or the destination for list mode lists and ASCII files.

**Example:** LIST:DEXC:MODE IMP  
'selects that ASCII files with frequency and level value pairs are imported and transferred into list mode lists.

```
LIST:DEXC:AFIL:SEL 'd:/user/listmode/import/list.csv'
'selects that ASCII file list.csv is imported.
```

```
LIST:DEXC:SEL 'd:/user/listmode/import/list_imp'
'selects that the ASCII file list.csv is imported into list mode list list_imp.
```

*RST value	Resolution	SCPI
-	-	Device-specific

**[SOURce<[1]>:]LIST:DEXChange:SElect <list\_name>**

The command selects the list mode list to be imported or exported.

The list mode files are stored with the fixed file extensions **\*.lsw** in a directory of the user's choice. The directory applicable to the commands is defined with the command `MMEMory:CDIR`. A path can also be specified in command `SOUR:LIST:DEXC:SEL`, in which case the files are stored or loaded in the specified directory.

**Example:**           `LIST:DEXC:MODE IMP`  
                      'selects that ASCII files with frequency and level value pairs are imported and transferred into list mode lists.

`LIST:DEXC:AFIL:SEL 'd:/user/listmode/import/list.csv'`  
                      'selects that ASCII file list.csv is imported.

`LIST:DEXC:SEL 'd:/user/listmode/import/list_imp'`  
                      'selects that the ASCII file list.csv is imported into list mode list list\_imp.

*RST value	Resolution	SCPI
-	-	Device-specific

**[SOURce<[1]>:]LIST:DWELI 1 ms ... 1 s**

The command sets the time for which the instrument retains a setting.

**Example:**           `"LIST:DWEL 15"`  
                      'each setting in the list is retained for 15 ms.

*RST value	Resolution	SCPI
10 ms	-	Compliant

**[SOURce<[1]>:]LIST:FREQuency 300 kHz...RF<sub>max</sub> {, 300 kHz...RF<sub>max</sub>} | block data (RF<sub>max</sub> depending on model)**

The command fills the FREQuency part of the selected list with data. The data can be given either as a list of numbers (list can be of any length and list entries must be separated by commas) or as binary block data. When block data is transferred, 8 (4) bytes are always interpreted as a floating-point number with double accuracy (see the command `FORMat:DATA`).

\*RST does not affect data lists.

**Example:**           `"LIST:SEL 'D:\Lists\Listmode\list3'"`  
                      'selects list3 for editing. List3 is created if it does not yet exist.

`"SOUR:LIST:FREQ 1.4GHz, 1.3GHz, 1.2GHz,..."`  
                      'specifies the frequency values in list3. If the list already contains data, it is overwritten.

*RST value	Resolution	SCPI
-	-	Compliant

[SOURce<[1]|2>:]LIST:FREQuency:POINts?

The command queries the length (in points) of the FREQuency component of the selected list.

The command is a query command and therefore has no \*RST value.

**Example:** "LIST:SEL 'D:\Lists\Listmode\list3'"  
 'selects list3 for editing. List3 is created if it does not yet exist.  
 "LIST:FREQ:POIN?"  
 'queries the number of frequency values in list3.  
 Response: "327"  
 'list3 has 327 frequency entries.

*RST value	Resolution	SCPI
-	-	Compliant

[SOURce<[1]|2>:]LIST:INDeX:STARt 0 ... list length

The command sets the start index of the index range which defines a subgroup of frequency/level value pairs in the current list. Only the values in the set index range (:LIST:INDeX:STARt ... :LIST:INDeX:STOP) are processed in List mode.

**Example:** "LIST:SEL 'D:\Lists\Listmode\list3'"  
 'selects list3 for use in List mode.  
 "LIST:IND:STAR 25"  
 'sets 25 as start index of the index range.  
 "LIST:IND:STOP 49"  
 'sets 49 as stop index of the index range.  
 "FREQ:MODE LIST"  
 'activates List mode. The frequency/level value pairs from index 25 to index 49 in list3 are processed. All other entries of the list are ignored.

*RST value	Resolution	SCPI
0	-	Device-specific

[SOURce<[1]|2>:]LIST:INDeX:STOP 0 ... list length

The command sets the stop index of the index range which defines a subgroup of frequency/level value pairs in the current list. Only the values in the set index range (:LIST:INDeX:STARt ... :LIST:INDeX:STOP) are processed in List mode.

**Example:** "LIST:SEL 'D:\Lists\Listmode\list3'"  
 'selects list3 for use in List mode.  
 "LIST:IND:STAR 25"  
 'sets 25 as start index of the index range.  
 "LIST:IND:STOP 49"  
 'sets 49 as stop index of the index range.  
 "FREQ:MODE LIST"  
 'activates List mode. The frequency/level value pairs from index 25 to index 49 in list3 are processed. All other entries of the list are ignored.

*RST value	Resolution	SCPI
0	-	Device-specific



**[SOURce<[1]>:]LIST:LEARn**

The command learns the selected list, i.e. it determines the hardware setting for the entire list. The data determined in this way is stored together with the list. When the list is activated for the first time, these settings are calculated automatically.

The command triggers an event and therefore has no \*RST value.

**Example:**           :LIST:SEL 'D:\Lists\Listmode\list3'"  
                      'selects list3. List3 is created if it does not yet exist.  
  
                      "LIST:LEAR"  
                      'starts learning of the hardware setting for list3 and stores the setting.

*RST value	Resolution	SCPI
-	-	Device-specific

**[SOURce<[1]>:]LIST:MODE AUTO | STEP**

The command specifies how the list is to be processed (similar to SOURce:SWEep:MODE).

**Parameters:**    **AUTO**  
                      Each trigger event triggers a complete list cycle. Possible trigger settings for :LIST:TRIGger:SOURce are AUTO, SINGLE and EXT.

**STEP**  
                      Each trigger event triggers only one step in the list processing cycle. Possible trigger settings for :LIST:TRIGger:SOURce are SINGLE and EXT

**Example:**           "LIST:MODE STEP"  
                      'selects step-by-step processing of the list.

*RST value	Resolution	SCPI
AUTO	-	Compliant

**[SOURce<[1]>:]LIST:POWer -145 ...30 dBm {, -145 ...30 dBm} | block data**

The command fills the Level part of the selected list with data. The data can be given either as a list of numbers (list can be of any length and list entries must be separated by commas) or as binary block data. When block data is transferred, 8 (4) bytes are always interpreted as a floating-point number with double accuracy (see the command FORMat:DATA).

\*RST does not affect data lists.

**Example:**           "LIST:SEL 'D:\Lists\Listmode\list3'"  
                      'selects list3 for editing. List3 is created if it does not yet exist.  
  
                      "LIST:POW 0dBm, 2dBm, 2dBm, 3dBm,.."   
                      'specifies the level values in list3. The number of level values must correspond to the number of frequency values. The previous data is overwritten.

*RST value	Resolution	SCPI
-	-	Compliant

**[SOURce<[1]>:]LIST:POWer:POINts?**

The command queries the length (in points) of the LEVel part of the selected list.

The command is a query command and therefore has no \*RST value.

**Example:**           "LIST:SEL 'D:\Lists\Listmode\list3'"  
                       'selects list3 for editing. List3 is created if it does not yet exist.  
                       "LIST:POW:POIN?"  
                       'queries the number of levels in list3.  
                       Response: "327"  
                       'LIST2 has 327 level entries.

*RST value	Resolution	SCPI
-	-	Compliant

**[SOURce<[1]>:]LIST:RESet**

The command resets the list to the starting point.

The command triggers an event and therefore has no reset value.

**Example:**           "LIST:RES"  
                       'resets the list to the starting point.

*RST value	Resolution	SCPI
-	-	Device-specific

**[SOURce<[1]>:]LIST:SElect '<list name>'**

The command selects the specified list. If a new list is to be created, the name can be entered here. The list is created if it does not yet exist. The list selected here is available for the further processing steps (editing) and is used in the instrument when the List mode is activated.

The files are stored with the fixed file extensions \*.lsw in a directory of the user's choice. The directory applicable to the command is defined with the command MMEMoRY:CDIR. A path can also be specified in command :SOUR:LIST:SEL in which case the list mode file in the specified directory is selected.

\*RST does not affect data lists.

**Example:**           "LIST:SEL 'D:\Lists\Listmode\list3'"  
                       'selects list3 for editing. List3 is created if it does not yet exist.

*RST value	Resolution	SCPI
-	-	Device-specific

**[SOURce<[1]|2>:]LIST:TRIGger:EXECute**

The command immediately starts the processing of a list in list mode. It corresponds to the manual-control command **Execute Single**.

The command triggers an event and therefore has no reset value.

**Example:** "SOUR:LIST:TRIG:EXEC"  
'triggers the processing of the selected list.

*RST value	Resolution	SCPI
-	-	Device-specific

**[SOURce<[1]|2>:]LIST:TRIGger:SOURce** AUTO | IMMEDIATE | SINGLE | EXTERNAL | BUS | EXTERNAL

The command sets the trigger source for the LIST mode.

The names of the parameters correspond to those under sweep mode. SCPI uses other names for the parameters; these names are also accepted by the instrument. The SCPI names should be used if compatibility is an important consideration. An overview of the various names is given in the following table:

R&S name	SCPI name	Command under manual control
AUTO	IMMEDIATE	MODE AUTO
SINGLE	BUS	MODE SINGLE or STEP
EXTERNAL	EXTERNAL	MODE EXT TRIG SINGLE or EXT TRIG STEP

**Parameters:**

**AUTO**

The trigger is free-running, i.e. the trigger condition is fulfilled continuously. The selected list in List mode is restarted as soon as it is finished.

**SINGLE**

The list is triggered by the IEC/IEEE-bus commands SOURce:LIST:TRIGger:EXECute. The list is executed once.

**EXTERNAL**

The list is triggered externally via the INST TRIG connector. The list is executed once.

**Example:**

"TRIG:LIST:SOUR EXT"  
'selects triggering by means of the external trigger. The trigger is input via the INST TRIG connector.

*RST value	Resolution	SCPI
SINGLE	-	Device-specific

## SOURce:MODulation Subsystem

This subsystem contains the command for switching on/off all modulations.

Command	Parameters	Default unit	Remark
[SOURce:]MODulation[:ALL]:STATe	ON   OFF		

### [SOURce:]MODulation[:ALL]:STATe ON | OFF

The command switches the modulations on and off. In the two-path mode, command :SOUR:MOD:ALL:STAT OFF switches all modulations off. A subsequent command :SOUR:MOD:ALL:STAT ON restores the status that was active before the last switch-off. **MOD OFF** is displayed in the info line of the header next to the **Level** field.

The keyword SOURce is optional. The setting is valid for both paths. If a suffix is specified, an error message is generated.

**Example:** "MOD:STAT OFF"  
'switches off all modulations.'

*RST value	Resolution	SCPI
IN	-	Device-specific

## SOURce:PHASe Subsystem

This subsystem contains the commands for adjusting the phase of the RF output signal relative to a reference signal of the same frequency.

In the case of two-path instruments with a second RF path, the numerical suffix under SOURce distinguishes between RF output A and RF output B:

SOURce[1]= RF output A

SOURce2 = RF output B

The keyword SOURce is optional with commands for RF output A and can be omitted. For RF output B, the command must contain the keyword together with the suffix 2.

For one-path instruments, the keyword SOURce is optional and can be omitted.

Command	Parameters	Default unit	Remark
[SOURce<[1] 2>:]PHASe	-359.9 deg ... +359.9 deg	RAD	
[SOURce<[1] 2>:]PHASe:REFerence			No query

### [SOURce<[1]|2>:]PHASe -359.9 deg ... +359.9 deg

The command specifies the phase variation relative to the current phase. The variation can be specified in RADians.

**Example:** "PHAS 2DEG"  
'changes the phase by 2 degrees relative to the current phase.

"PHAS : REF"  
'adopts the set phase as the current phase.

*RST value	Resolution	SCPI
0.0 deg	0.1 deg	Compliant

### [SOURce<[1]|2>:]PHASe:REFerence

The command adopts the phase set with SOURce:PHASe:ADJust as the current phase.

The command triggers an event and therefore has no \*RST value and no query form.

**Example:** "PHAS 0.1RAD"  
'changes the phase by 0.1 rad relative to the current phase.

"PHAS : REF"  
'adopts the set phase as the current phase.

*RST value	Resolution	SCPI
-	-	Compliant

## SOURce:PM Subsystem

The PM subsystem contains the commands for checking the phase modulation. The settings for the internal modulation source (LF generator) are made in the SOURce:LFOuTput subsystem.

Phase modulation requires option R&S SMJ-B20 (PM/PhiM Modulator). The keyword SOURce is optional and can be omitted.

Command	Parameters	Default unit	Remark
[SOURce<[1]>:]PM[:DEVIation]	0 ...20 RAD	RAD	
[SOURce<[1]>:]PM:EXtErnal:COUPling	AC   DC		
[SOURce<[1]>:]PM:MODE	HBANdwidth   HDEVIation   LNOise		
[SOURce<[1]>:]PM:SENSitivity?			Query only
[SOURce<[1]>:]PM:SOURce	EXT   INT   INT, EXT		
[SOURce<[1]>:]PM:STATe	ON   OFF		

### [SOURce<[1]>:]PM[:DEVIation] 0 ... 20 RAD

The command sets the modulation deviation of the phase modulation in RAD. The maximal deviation depends on the RF frequency set and the selected modulation mode (see data sheet).

**Example:** "PM 5"  
'sets the PM modulation deviation to 5 RAD.

*RST value	Resolution	SCPI
1 RAD	See data sheet	Compliant

### [SOURce<[1]>:]PM:EXtErnal:COUPling AC | DC

The command selects the coupling mode for the external modulation input (EXT MOD) in the case of phase modulation.

**Note:**

*Coupling for external feed via input EXT MOD can be set independently for modulations AM, PM and PhiM.*

**Parameters:** **AC**  
The DC voltage component is disconnected from the modulation signal.

**DC**  
The modulation signal is not changed.

**Example:** "PM:EXT:COUP AC"  
'selects the coupling mode AC for external phase modulation.

*RST value	Resolution	SCPI
AC	-	Compliant

[SOURCE<[1]>:]PM:MODE HBANdwidth | HDEVIation | LNOise

The command selects the mode for the phase modulation.

**Parameters:**

**HBANdwidth**

The maximum range for modulation bandwidth is available. However, phase noise is increased for low frequencies. The range for PhiM deviation is limited. This mode is recommended for high modulation frequencies.

**HDEVIation**

The maximum range for PhiM deviation is available. Phase noise is improved for low frequencies. The range for modulation frequency is limited (see data sheet). This mode is recommended for low modulation frequencies and/or high PhiM deviation.

**LNOise**

Phase modulation with phase noise and spurious characteristics close to CW mode. The range for modulation bandwidth and PM deviation is limited (see data sheet)

**Example:**

"PM:MODE LNO"  
'selects Low Noise mode for external phase modulation.

*RST value	Resolution	SCPI
HBANdwidth	-	Compliant

[SOURCE<[1]>:]PM:SENSitivity?

The command queries the input sensitivity of the EXT MOD input in RAD/V. The command is only effective if the external modulation source is selected (SOURCE:PM:SOUR EXT). The returned value depends on the modulation deviation setting (SOURCE:PM:DEVIation). This value is assigned to the voltage value for full modulation of the input.

The command is a query command and therefore has no \*RST value.

**Example:**

"PM:DEV 1"  
'sets a modulation deviation of 1RAD.  
"PM:SENS?"  
'queries the input sensitivity at the EXT MOD input.  
Response: "1"  
'since the voltage value for full modulation is 1V, the resulting sensitivity is precisely 1RAD/V.

*RST value	Resolution	SCPI
-	-	Compliant

[SOURCE<[1]>:]PM:SOURce EXT | INT | INT,EXT

The command selects the modulation source for phase modulation. INT is the LF generator. The frequency of the internal modulation signal can be set in the SOURCE:LFOuTput subsystem. The external signal is input at the EXT MOD connector. Internal and external modulation source can be selected at the same time.

**Example:**

"PM:SOUR INT"  
'selects the internal modulation source.

*RST value	Resolution	SCPI
INTernal	-	Compliant

[SOURce<[1]|2>:]PM:STATe ON | OFF

The command activates/deactivates phase modulation.  
Activation of phase modulation deactivates phase modulation.

**Example:** "PM:STAT ON"  
'activates PM modulation.

*RST value	Resolution	Correlation	SCPI
OFF	-	PM:STATe ON deactivates phase modulation.	Compliant



## SOURce:POWer Subsystem

This subsystem contains the commands for setting the output level, level control and level correction of the RF signal. Other units can also be used instead of dBm:

by entering the unit directly after the numerical value (example : POW 0.5V),

by changing the DEFault unit in the UNIT system (see the command UNIT:POWER).

In the case of two-path instruments with a second RF path, the numerical suffix under SOURce distinguishes between RF output A and RF output B:

SOURce[1] = RF output A

SOURce2 = RF output B

The keyword SOURce is optional with commands for RF output A and can be omitted. For RF output B, the command must contain the keyword together with the suffix 2.

For one-path instruments, the keyword SOURce is optional and can be omitted.

Command	Parameters	Default unit	Remark
[SOURce<[1] 2>:]POWer:ALC:OMODE	SHOLd		
[SOURce<[1] 2>:]POWer:ALC:SONCe			No query
[SOURce<[1] 2>:]POWer:ALC[:STATe]	ON   OFF   AUTO		
[SOURce<[1] 2>:]POWer:[LEVEL][:IMMEDIATE][:AMPLitude]	<numeric_value>	dBm	Depending on model
[SOURce<[1] 2>:]POWer:[LEVEL][:IMMEDIATE]:OFFSet	-100 ...+100 dB	dB	Depending on model
[SOURce<[1] 2>:]POWer:[LEVEL][:IMMEDIATE]:RCL	INCLude   EXCLude		
[SOURce<[1] 2>:]POWer:LIMit[:AMPLitude]	<numeric_value>	dBm	Depending on model
[SOURce<[1] 2>:]POWer:MANual	<numeric_value>	dBm	Depending on model
[SOURce<[1] 2>:]POWer:MODE	FIXed CW   SWEEp   LIST		
[SOURce<[1] 2>:]POWer:PEP?		dBm	Query only
[SOURce<[1] 2>:]POWer:START	<numeric_value>	dBm	Depending on model
[SOURce<[1] 2>:]POWer:STEP[:INCRement]	0 ...100 dB	dB	
[SOURce<[1] 2>:]POWer:STEP:MODE	USER   DECimal		
[SOURce<[1] 2>:]POWer:STOP	<numeric_value>	dBm	Depending on model

**[SOURce<[1]>:]POWer:ALC:OMODe SHOLd**

The command sets the level control mode which becomes active when automatic level control is deactivated (**ALC Off**).

**Parameter:**       **SHOLd**  
                           Level control is activated briefly if the level or frequency changes (**ALC Off Sample & Hold**).

**Example:**       "POW:ALC OFF"  
                           'deactivates automatic level control for RF output A.  
                           "POW:ALC:OMOD SHOL"  
                           'level control is briefly activated if the frequency or level changes.

*RST value	Resolution	SCPI
SHOLd		Device-specific

**[SOURce<[1]>:]POWer:ALC:SONCe**

The command briefly activates level control for correction purposes.

The command triggers an event and therefore has no \*RST value and no query form.

**Example:**       "POW:ALC OFF"  
                           'deactivates automatic level control for RF output A.  
                           "POW:ALC:SONC"  
                           'level control is performed once only.

*RST value	Resolution	SCPI
-	-	Device-specific

**[SOURce<[1]>:]POWer:ALC[:STATe] ON | OFF | AUTO**

The command activates/deactivates automatic level control.

**Parameters:**    **ON**  
                           Internal level control is permanently activated.  
                           **OFF**  
                           Internal level control is deactivated, Sample & Hold mode is activated.  
                           **AUTO**  
                           Internal level control is activated/deactivated automatically depending on the operating state.

**Example:**       "POW:ALC ON"  
                           'activates automatic level control for RF output A.

*RST value	Resolution	SCPI
AUTO	-	Compliant

**[SOURce<[1]|2>:]POWer[:LEVel][:IMMediate][:AMPLitude]** Minimum level ... Maximal level

The command sets the RF output level in CW mode. In addition to numerical values, it is also possible to specify UP and DOWN. The level is then increased or decreased by the value specified under [SOURce<[1]|2>:]POWer:STEP.

As with the **Level** value entered in the header, the **OFFSet** value is also taken into consideration with this command.

The specified value range is therefore only effective if :SOURce:POWer:OFFSet is set to 0. The value range for other OFFSet values can be calculated using the following formula:

Minimum level + OFFSet ...Maximum level + OFFSet

The keywords of this command are largely optional. Therefore, both the long and short form of the command are shown in the example.

**Parameters: Minimum level ... Maximum level**

The value range for the level setting varies according to the instrument model. The values are given in the data sheet.

**Example:** "SOUR:POW:LEV:IMM:AMPL 15" or ":POW 15"  
'sets the RF level at output A to 15 dBm.

*RST value	Resolution	SCPI
-30 dBm	0.01 dB	Compliant

**[SOURce<[1]|2>:]POWer[:LEVel][:IMMediate]:OFFSet** -100 dB ... +100 dB**Caution:**

*The level offset is also effective for level sweeps!*

The command specifies the constant level offset of a downstream attenuator/amplifier. If a level offset is entered, the level entered with :POWer no longer corresponds to the RF output level. The following correlation applies:

$$:POWer = \text{RF output level} + \text{POWer:OFFSet}.$$

Entering a level offset does not change the RF output level, but rather the query value of :POWer.

Only dB is permitted as the unit here. The linear units (V, W, etc.) are not permitted.

The keywords of this command are largely optional. Therefore, both the long and short form of the command are shown in the example.

**Example:** "SOURce:POWer:LEVel:IMMediate:OFFSet -10"  
or  
"POW:OFFS 10"  
'sets the RF level offset to 10 dB.

*RST value	Resolution	SCPI
0 dB	0.01 dB	Compliant

**[SOURce:]POWer[:LEVel][:IMMediate]:RCL INCLude | EXCLude**

The command determines whether the current level is retained or whether the stored level setting is adopted when an instrument configuration is loaded.

\*RST does not affect this setting. The setting is valid for both paths. If a suffix is specified, it is ignored.

**Parameters:**      **INCLude**  
                             The stored level is also loaded when a stored instrument configuration is loaded.

**EXCLude**  
                             The RF level is not loaded when a stored instrument configuration is loaded. The current level is retained.

**Example:**           "POW:RCL INCL"  
                             'the stored level is set if the Recall command is called.

*RST value	Resolution	SCPI
-	-	Compliant

**[SOURce<[1]]2>:POWer:LIMit[:AMPLitude] Minimum level ... Maximum level**

The command limits the maximum RF output level in CW and SWEEP mode. It does not influence the LEVEL display or the response to the POW? query command.

**Parameters:**      **Minimum level ... Maximum level**  
                             The value range for the level setting varies according to the instrument model. The values are given in the data sheet.

**Example:**           "SOURCE:POWER:LIMIT:AMPLITUDE 10" or ":POW:LIM 10"  
                             'limits the RF level to maximum +10 dBm.

*RST value	Resolution	SCPI
+30 dBm	0.01 dB	Compliant

**[SOURce<[1]]2>:POWer:MANual Minimum level ... Maximum level**

In Sweep mode (:SOUR:POW:MODE SWE) the command sets the level for the next sweep step in the **Step** sweep mode (:SOUR:SWE:POW:MODE MAN). Here only level values between the settings [:SOUR]:POW:STAR and ...:STOP are permitted. Each sweep step is triggered by a separate :SOUR:POW:MAN command.

As with the **Level** value entered in the **RF Level** menu, the **OFFSet** value is also taken into consideration with this command.

The specified value range is therefore only effective if :SOURce:POWer:OFFSet is set to 0. The value range for other OFFset values can be calculated using the following formula:

Minimum level + OFFSet ... Maximum level + OFFSet

**Parameters:**      **Minimum level ... Maximum level**  
                             The value range for the level setting varies according to the instrument model. The values are given in the data sheet.

**Example:**           "POW:SWE:MODE MAN"  
                             'sets the **Step** sweep mode for RF output A.  
                             "POW:MAN -5 dBm"  
                             'sets an RF level of -5 dBm for the next setting in the **Step** sweep mode for RF output A.

```
"POW:MODE SWE"
'sets the Level Sweep mode for RF output A.

"POW:MAN -5.5 dBm"
'triggers the next sweep step with a level of -5.5 dBm.
```

*RST value	Resolution	SCPI
-30 dBm	0.01 dBm	Compliant

**[SOURce<[1]|2>:]POWer:MODE CW|FIXed | SWEep | LIST**

The command sets the instrument operating mode and therefore also the commands used to set the output level.

**Parameters:**      **CW|FIXed**  
 The instrument operates at a constant level. CW and FIXed are synonyms. The output level is set with :SOURce:POWer.

**SWEep**  
 The instrument operates in SWEep mode. The level is set using the commands SOURce:POWer:STARt; STOP; MANual.

**LIST**  
 The instrument processes a list of frequency and level settings. The List mode settings are made in the SOURce:LIST subsystem. The setting SOURce:POWer:MODE LIST also sets the command SOURce:FREQuency:MODE automatically to LIST.

**Example:**      "POW:MODE SWEep"  
 'sets the SWEep mode. The settings under SOURce:POW:STARt; STOP; MANual become effective.

*RST value	Resolution	Correlation	SCPI
CW	-	POW:MODE LIST sets FREQ:MODE LIST	Compliant

**[SOURce<[1]|2>:]POWer:PEP?**

With digital modulation and all digital standards, the command returns the peak envelope power (PEP) in dBm (the value which is shown under the **Level** specification in the PEP lines in the display header).

The command is a query and therefore has no \*RST value.

**Example:**      "POW:PEP?"  
 'queries the PEP value for RF output A in the case of digital modulation.

Response: "4"  
 'the PEP value for RF output A is 4 dBm.

*RST value	Resolution	SCPI
--	-	Compliant

[SOURce<[1]>:]POWer:STARt Minimum level ... Maximum level

The command sets the RF start level in Sweep mode.

As with the **Level** value entered in the **RF Level** menu, the **OFFSet** value is also taken into consideration with this command.

The specified value range is therefore only effective if :SOURce:POWer:OFFSet is set to 0. The value range for other OFFset values can be calculated using the following formula:

Minimum level + OFFSet ...Maximum level + OFFSet

**Parameters:** Minimum level ... Maximum level

The value range for the level setting varies according to the instrument model. The values are given in the data sheet.

**Example:** "POW:STAR -20 dBm"  
'sets the start level for the level sweep to -15 dBm for RF output A.

*RST value	Resolution	SCPI
-30 dBm	0.01 dB	Compliant

[SOURce<[1]>:]POWer:STEP[:INCRement] 0 dB ... 100dB

The command sets the step width for the level setting if UP and DOWN are used as the level values and variation mode :SOUR:POW:STEP:MODE USER is selected. The command is linked to setting **Variation Step** for manual control, i.e. the command also sets the step width of the rotary knob for **Variation Active on**. In the case of two-path instruments, the step width can be set separately for each path.

**Example:** "SOURce:POWer:STEP:INCRement 2" or "POW:STEP 2"  
'sets the step width for entering the RF level to 2 dB.

*RST value	Resolution	SCPI
1 dB	0.01 dB	Device-specific

[SOURce<[1]>:]POWer:STEP:MODE USER | DECimal

This command activates (USER) or deactivates (DECimal) the user-defined step width used when varying the level value with the level values UP/DOWN. The command is linked to setting **Variation Active** for manual control, i.e. the command also activates/deactivates the user-defined step width used when varying the level value with the rotary knob. In the case of two-path instruments, the step width can be set separately for each path.

**Example:** "POW:STEP 2"  
'sets the step width for the level setting to 2 dB.  
"POW:STEP:MODE USER"  
'activates this step width for level variation with the rotary knob (manual control) and with level values UP/DOWN (remote control).

*RST value	Resolution	SCPI
DECimal	-	Device-specific

**[SOURce<[1]|2>:]POWer:STOP** Minimum level ... Maximum level

The command sets the stop level in Sweep mode.

As with the **Level** value entered in the **RF Level** menu, the **OFFSet** value is also taken into consideration with this command.

The specified value range is therefore only effective if: **SOURce:POWer:OFFSet** is set to 0. The value range for other **OFFSet** values can be calculated using the following formula:

$$\text{Minimum level} + \text{OFFSet} \quad \dots \quad \text{Maximum level} + \text{OFFSet}$$

**Parameters: Minimum level ... Maximum level**

The value range for the level setting varies according to the instrument model. The values are given in the data sheet.

**Example:** "POW:STOP 3"  
'sets the stop level for the level sweep to 3 dBm for RF output A.

*RST value	Resolution	SCPI
-10 dBm	0.01 dB	Compliant

## SOURce:PULM Subsystem

This subsystem contains the commands for setting the pulse modulation.

The LF generator is used as the internal modulation source. The pulse frequency of the internal rectangular signal is therefore set in the SOURce:LFOutput subsystem.

The external modulation signal is input at the EXT MOD connector at the rear of the R&S Vector Signal Generator.

In the case of two-path instruments with a second RF path, the pulse modulation can be set separately and independently for the two RF outputs. The suffix under SOURce distinguishes the outputs:

SOURce[1] = RF output A

SOURce2 = RF output B

The keyword SOURce is optional with commands for RF output A and can be omitted. For RF output B, the command must contain the keyword together with the suffix 2.

In case of one-path instruments, the keyword SOURce is optional and can be omitted.

Command	Parameters	Default unit	Remark
[SOURce<[1] 2>:]PULM:POLarity	NORMal   INVerted		
[SOURce<[1] 2>:]PULM:SOURce	INT   EXT		
[SOURce<[1] 2>:]PULM:STATe	ON   OFF		

### [SOURce<[1]|2>:]PULM:POLarity NORMal | INVerted

The command sets the polarity between modulating and modulated signal. This command is only effective for an external modulation signal.

**Parameters:**      **NORMal**

The RF signal is suppressed during the pulse pause.

**INVerted**

The RF signal is suppressed during the pulse.

**Example:**

"PULM:SOUR EXT"

'selects the external modulation source.

"PULM:POL INV"

'selects inverted polarity.

*RST value	Resolution	SCPI
NORMal	-	Device-specific



[SOURce<[1]|2>:]PULM:SOURce INTernal | EXTernal | CODer

The command selects the source for pulse modulation.

**Parameters:**     **INTernal**  
 The internally generated rectangular signal is used for the pulse modulation.  
 The frequency of the internal signal can be set in the SOURce:LFOOutput subsystem.

**EXTernal**  
 The signal applied externally via the EXT MOD connector is used for the pulse modulation.

**Example:**        "PULM:SOUR INT"  
                       'selects the internal modulation source.  
                       "PULM:STAT ON"  
                       'activates the pulse modulation.

*RST value	Resolution	SCPI
INTernal	-	Compliant

[SOURce<[1]|2>:]PULM:STATe ON | OFF

The command activates/deactivates the pulse modulation.

**Example:**        "PULM:STAT ON"  
                       'activates pulse modulation with the modulation source selected under SOURce:PULM:SOURce.

*RST value	Resolution	SCPI
OFF	-	Compliant

## SOURce:ROSCillator Subsystem

This subsystem contains the commands for setting the external and internal reference frequency.

In the case of two-path instruments, this setting is effective for all paths. No suffix should therefore be specified under SOURce.

**Note:**

The commands of the SOURce:ROSCillator Subsystem are not affected by an instrument reset (\*RST)

Command	Parameters	Default unit	Remark
[SOURce:]ROSCillator:EXTernal:FREQuency	5 MHz   10 MHz   13 MHz	Hz	
[SOURce:]ROSCillator:EXTernal:SBANdwidth			
[SOURce:]ROSCillator[:INTernal]:ADJust[:STATe]	ON   OFF		
[SOURce:]ROSCillator[:INTernal]:ADJust:VALue	0 ... 4095		
[SOURce:]ROSCillator:SOURce	INTernal   EXTernal		

### [SOURce:]ROSCillator:EXTernal:FREQuency 5 MHz | 10 MHz | 13 MHz

The command informs the instrument of the frequency of the external reference.

**Example:**       "ROSC:SOUR EXT"  
                      'selects the external source. The reference must be input at the REF IN input.

                      "ROSC:EXT:FREQ 5 MHz"  
                      'informs the instrument that the external reference frequency is 5 MHz.

*RST value	Resolution	SCPI
-	-	Compliant

### [SOURce:]ROSCillator:EXTernal:SBANdwidth NARRow | WIDe

The command selects the synchronization bandwidth for an external reference signal.

**Parameters:**   **NARRow**  
                      Synchronization bandwidth is approx. 1 Hz.

**WIDe**  
                      Synchronization bandwidth is approx. 750 Hz.

**Example:**       "ROSC:SOUR EXT"  
                      'selects the external source.

                      "ROSC:EXT:FREQ 5 MHz"  
                      'informs the instrument that the external reference has a frequency of 5 MHz.

                      "ROSC:EXT:SBAN WID"  
                      'selects wideband setting for synchronization bandwidth.

*RST value	Resolution	SCPI
-	-	Device-specific

**[SOURce:]ROSCillator[:INTernal]:ADJust:VALue 0 ... 4095**

The command specifies the frequency correction value (adjustment value).

**Example:**       "ROSC:ADJ:VAL 1400"  
                  'sets the adjustment value to 1400.

*RST value	Resolution	SCPI
-	1	Device-specific

**[SOURce:]ROSCillator[:INTernal]:ADJust[:STATe] ON | OFF**

The command determines whether the calibrated (OFF) or a user-defined (ON) adjustment value is used for fine adjustment of the frequency. With STATe ON, the instrument is no longer in the calibrated state. However, the calibration value is not changed and the instrument resumes the calibrated state after switching the Adjustment State to Off.

**Example:**       "ROSC:SOUR INT"  
                  'selects the internal source.  
  
                  "ROSC:ADJ ON"  
                  'activates use of a user-defined adjustment value.  
  
                  "ROSC:ADJ:VAL 1400"  
                  'sets the adjustment value to 1400.

*RST value	Resolution	SCPI
-	-	Device-specific

**[SOURce:]ROSCillator:SOURce INTernal | EXTernal**

The command selects between internal and external reference frequency.

**Parameters:**   **INTernal**  
                  The internal reference oscillator is used.

**EXTernal**  
An external reference signal is used. It must be input at the REF IN connector at the rear of the instrument. The instrument is informed of the frequency of the external reference signal by means of the command  
SOURce:ROSCillator:EXTernal:FREQuency.

**Example:**       "ROSC:SOUR EXT"  
                  'selects the external source.  
  
                  "ROSC:EXT:FREQ 5 MHz"  
                  'informs the instrument that the external reference has a frequency of 5 MHz.

*RST value	Resolution	SCPI
-	-	Device-specific

## SOURce:SWEep Subsystem

This subsystem contains the commands for checking the RF sweeps, i.e. the sweeps of the RF generators. Sweeps are always triggered, except for the `MANual` sweep mode. The frequency sweep is activated by the command `SOURce:FREQuency:MODE SWEep`, and the level sweep by the command `SOURce:POWer:MODE SWEep`. All sweeps, including the LF sweep, can be set independently of each other.

In the case of two-path instruments with a second RF path, the numerical suffix under `SOURce` distinguishes between RF output A and RF output B:

`SOURce<1>` = RF output A

`SOURce2` = RF output B

The keyword `SOURce` is optional with commands for RF output A and can be omitted. For RF output B, the command must contain the keyword together with the suffix 2.

For one-path instruments, the keyword `SOURce` is optional and can be omitted.

A sweep is set in several steps which are shown below taking a frequency sweep as an example:

1. Set the sweep range.

```
[SOURce<[1]|2>:]FREQuency:CENTer 200 MHz
```

```
[SOURce<[1]|2>:]FREQuency:SPAN 300 MHz
```

2. Select linear or logarithmic spacing.

```
[SOURce<[1]|2>:]SWEep[:FREQuency]:SPACing LIN
```

3. Set the step width and dwell time.

```
[SOURce<[1]|2>:]SWEep[:FREQuency]:STEP:LINear 20 MHz
```

```
[SOURce<[1]|2>:]SWEep[:FREQuency]:DWELL 12 ms
```

4. Select the trigger mode.

```
TRIGGer<[1]|2>:FSWeep:SOURce SINGLE
```

5. Select the sweep mode and activate the sweep.

```
[SOURce<[1]|2>:]SWEep[:FREQuency]:MODE AUTO
```

```
[SOURce<[1]|2>:]FREQuency:MODE SWEep
```

6. Trigger the sweep.

```
[SOURce<[1]|2>:]SWEep[:FREQuency]:EXECute
```

Command	Parameters	Default unit	Remark
[SOURCE<[1]>:]SWEep:FREQuency:DWELI	2 ms ... 10 s	s	
[SOURCE<[1]>:]SWEep:FREQuency:EXECute	-		
[SOURCE<[1]>:]SWEep:FREQuency:MODE	AUTO   MANual   STEP		
[SOURCE<[1]>:]SWEep:FREQuency:POINts	<numeric_value>		
[SOURCE<[1]>:]SWEep:FREQuency:SHAPE	SAWTooth   TRIangle		
[SOURCE<[1]>:]SWEep:FREQuency:SPACing	LINear   LOGarithmic		
[SOURCE<[1]>:]SWEep:FREQuency:STEP:LINear	0 ... (STOP - STARt)	Hz	
[SOURCE<[1]>:]SWEep:FREQuency:STEP:LOGarithmic	0.01 ... 9999 PCT		
[SOURCE<[1]>:]SWEep:POWer:AMODE	NORMal   HPOWer		
[SOURCE<[1]>:]SWEep:POWer:DWELI	2 ms...10 s	s	
[SOURCE<[1]>:]SWEep:POWer:EXECute	-		
[SOURCE<[1]>:]SWEep:POWer:MODE	AUTO   MANual   STEP		
[SOURCE<[1]>:]SWEep:POWer:POINts	<numeric_value>		
[SOURCE<[1]>:]SWEep:POWer:SHAPE	SAWTooth   TRIangle		
[SOURCE<[1]>:]SWEep:POWer:SPACing:MODE			Query only
[SOURCE<[1]>:]SWEep:POWer:STEP:[LOGarithmic]	0.1 ...20 dB		
[SOURCE<[1]>:]SWEep:RESet:ALL]			No query

**[SOURCE<[1]>:]SWEep:FREQuency:DWELI 3 ms...10 s**

The command sets the time taken for each frequency step of the sweep.

The keyword [:FREQuency] can be omitted (see example). The command is then SCPI-compliant.

**Example:** "SWE:DWEL 12 ms"  
 'sets a dwell time of 12 ms for a frequency sweep at the RF output.

*RST value	Resolution	SCPI
10 ms	0.1 ms	Device-specific

**[SOURCE<[1]>:]SWEep:FREQuency:EXECute**

The command triggers a sweep.

The command triggers an event and therefore has no query form and no \*RST value.

**Example:** "SWE:FREQ:EXEC"  
 'triggers a frequency sweep at the RF output.

*RST value	Resolution	SCPI
-	-	Device-specific

[SOURce<[1]>:]SWEep[:FREQuency]:MODE AUTO | MANual | STEP

The command sets the sweep mode.

The keyword [:FREQuency] can be omitted (see example). The command is then SCPI-compliant.

**Parameters:**       **AUTO**  
                           Each trigger triggers exactly one complete sweep.

**MANual**  
 The trigger system is not active. Each frequency step of the sweep is triggered individually, either by varying the **Current Frequency** value using the rotary knob under manual control or by means of a `FREQ:MAN` command under remote control. With manual control, the frequency increases or decreases (depending on the direction of the rotary encoder) by the value specified under `FREQ:STEP:INCRement`. With remote control, the frequency is set directly with the command `:FREQ:MAN`.

**STEP**  
 Each trigger triggers one sweep step only (**Mode Single Step**). The frequency increases by the value entered under `SOUR:SWE:FREQ:STEP:LIN` (linear spacing) or `...:STEP:LOG` (logarithmic spacing).

**Example:**       " SWE:MODE AUTO"  
                           'selects **Mode Auto** for a frequency sweep at the RF output.

*RST value	Resolution	SCPI
AUTO	-	Device-specific

[SOURce<[1]>:]SWEep[:FREQuency]:POINTs <numeric\_value>

The command sets the number of steps in an RF sweep. The command is linked to the command `:SWEep[:FREQuency]:STEP` as follows:

The following applies for linear sweeps:      $POINTs = (SPAN / STEP:LIN) + 1$

The following applies for logarithmic sweeps and `START < STOP`:  
 $POINTs = ((\log STOP - \log START) / \log STEP:LOG) + 1$

If `POINTs` changes, the value of `STEP` is adjusted. The `START` and `STOP` value is retained.

Two separate `POINTs` values are used for linear or logarithmic sweep spacing (`:SWEep[:FREQuency]:SPACing LIN | LOG`). The command is always effective for the currently set sweep spacing.

**Example:**       " FREQ:STAR"  
                           'sets the start frequency to 100 MHz.  
                           " FREQ:STOP"  
                           'sets the stop frequency to 500 MHz.  
                           " SWE:SPAC LIN"  
                           'sets linear sweep spacing.  
                           " SWE:POIN 401"  
                           'sets 401 sweep steps for linear sweep spacing. The sweep step width (`STEP`) is automatically set to 1 MHz.

*RST value	Resolution	Correlation	SCPI
	-	The value of <code>:SWE:STEP</code> is adjusted automatically.	Device-specific (adapted to instrument properties)

**[SOURce:]SWEep[:FREQuency]:SHAPE** SAWTooth | TRiangle

The command sets the cycle mode for a sweep sequence (shape).

**Parameters:**     **SAWTooth**

One sweep runs from start to stop frequency. Each subsequent sweep starts at the start frequency, i.e. the shape of the sweep sequence resembles a sawtooth.

**TRiangle**

One sweep runs from start to stop frequency and back, i.e. the shape of the sweep resembles a triangle. Each subsequent sweep starts at the start frequency.

**Example:**

SOUR:SWE:SHAP TRI  
'selects the sweep cycle with alternating ascending and descending sweep directions.

*RST value	Resolution	Options	SCPI
SAWTooth	-		Device-specific

**[SOURce<[1]|2>:]SWEep[:FREQuency]:SPACing** LINear | LOGarithmic

The command selects linear or logarithmic sweep spacing.

The keyword [:FREQuency] can be omitted (see example). The command is then SCPI-compliant.

**Example:**

"SWE:SPAC LIN"  
'selects linear sweep spacing for a frequency sweep at the RF output.

*RST value	Resolution	SCPI
LIN	-	Device-specific

**[SOURce<[1]|2>:]SWEep[:FREQuency]:STEP[:LINear] 0 ... (STOP - START)**

The command sets the step width for linear sweeps.

This command is linked to the command :SWEep[:FREQuency]:POINTs as follows:

$$POINTs = (SPAN / STEP:LIN) + 1$$

If STEP:LIN changes, the value of POINTs is adjusted. The START and STOP value is retained.

The keywords [:FREQuency] and [:LINear] can be omitted (see example). The command is then SCPI-compliant.

**Example:**

"FREQ:STAR"  
'sets the start frequency to 100 MHz.  
"FREQ:STOP"  
'sets the stop frequency to 500 MHz.  
"SWE:SPAC LIN"  
'sets linear sweep spacing.  
"SWE:STEP 2 MHz"  
'sets the step width for linear sweep spacing to 2 MHz (RF sweep at the RF output. The number of sweep steps for linear sweep spacing (POINTs) is automatically set to 201.

*RST value	Resolution	Correlation	SCPI
1 MHz	0.1 Hz.	The value of :SWE:POINTs is adjusted automatically.	Device-specific

**[SOURce<[1]|2>:]SWEep[:FREQuency]:STEP:LOGarithmic 0.01 ... 9999 PCT**

The command specifies the step width factor for logarithmic sweeps. The next frequency value of a sweep is calculated (for START < STOP) using the following formula:

$$\text{New frequency} = \text{Old frequency} + \text{STEP:LOG} \times \text{Old frequency}$$

STEP:LOG therefore gives the fraction of the old frequency. The frequency is increased by this fraction for the next sweep step. Usually STEP:LOG is given in percent, whereby the suffix PCT must always be used.

The command is linked to the command :SWEep[:FREQuency]:POINTs for START < STOP as follows:

$$\text{POINTs} = ((\log \text{STOP} - \log \text{START}) / \log \text{STEP:LOG}) + 1$$

If STEP:LOG changes, the value of POINTs is adjusted. The START and STOP value is retained.

**Example:** "FREQ:STAR"  
 'sets the start frequency to 100 MHz.  
 "FREQ:STOP"  
 'sets the stop frequency to 500 MHz.  
 "SWE:SPAC LOG"  
 'sets logarithmic sweep spacing.  
 "SWE:STEP:LOG 10PCT"  
 'sets the step width for logarithmic sweep spacing to 10% of the previous frequency in each instance (for a frequency sweep at the RF output.

*RST value	Resolution	Correlation	SCPI
1 PCT	0.01 PCT	The value of :SWE:POIN is adjusted automatically.	Device-specific

**[SOURce<[1]|2>:]SWEep:POWer:DWELI 2 ms...10 s**

The command sets the time taken for each level step of the sweep.

**Example:** "SWE:POW:DWEL 12 ms"  
 'sets a dwell time of 12 ms for a level sweep at the RF output.

*RST value	Resolution	SCPI
10 ms	0.1 ms	Device-specific

**[SOURce<[1]|2>:]SWEep:POWer:EXECute**

The command triggers a sweep.

The command triggers an event and therefore has no query form and no \*RST value.

**Example:** "SWE:POW:EXEC"  
 'triggers a level sweep at the RF output.

*RST value	Resolution	SCPI
-	-	Device-specific



[SOURCE<[1]|2>:]SWEep:POWer:MODE AUTO | MANual | STEP

The command sets the cycle mode of the level sweep.

**Parameters:** **AUTO**

Each trigger triggers exactly one complete sweep.

**MANual**

The trigger system is not active. Each level step of the sweep is triggered individually, either by varying the **Current Level** value using the rotary knob under manual control or by means of a POW:MAN command under remote control. With manual control, the level increases or decreases (depending on the direction of the rotary encoder) by the value specified under

POW:STEP:INCRement. With remote control, the level is set directly with the command POW:MAN.

**STEP**

Each trigger triggers one sweep step only. The level increases by the value entered under :SWEep:POWer:STEP:LOGarithmic.

**Example:** "SWE:POW:MODE AUTO"  
'selects **Mode Auto** for a level sweep at RF output.

*RST value	Resolution	SCPI
AUTO	-	Device-specific

[SOURCE<[1]|2>:]SWEep:POWer:POINts <numeric\_value>

The command sets the number of steps in a level sweep. The command is linked to the command :SWEep:POWer:STEP as follows:

$$POINts = ((STOP - START) / STEP:LOG) + 1$$

If POINts changes, the value of STEP is adjusted. The START and STOP value is retained.

**Example:** "POW:STAR - 30 dBm"  
'sets the start frequency to -30 dBm.  
"POW:STOP - 10 dBm"  
'sets the stop frequency to -10 dBm.  
"SWE:POW:POIN 20"  
'sets 20 sweep steps. The sweep step width (STEP) is automatically set to 1 dB.

*RST value	Resolution	Correlation	SCPI
20 dB	-	The value of :SWE:POW:STEP is adjusted automatically.	Device-specific (adapted to instrument properties)

[SOURCE:]SWEep:POWer:SHAPE SAWTooth | TRIangle

The command sets the cycle mode for a sweep sequence (shape).

**Parameters:** **SAWTooth**

One sweep runs from the start level to the stop level. The subsequent sweep starts at the start level again, i.e. the shape of sweep sequence resembles a sawtooth.

**TRIangle**

One sweep runs from start to stop level and back, i.e. the shape of the sweep resembles a triangle. Each subsequent sweep starts at the start level again.

**Example:** SOUR:SWE:POW:SHAP TRI  
 'selects the sweep cycle with alternating ascending and descending sweep directions.

*RST value	Resolution	Options	SCPI
SAWTooth	-		Device-specific

**[SOURce<[1]|2>:]SWEep:POWer:SPACing:MODE?**

The command queries the sweep spacing. The sweep spacing for level sweeps is always linear. This command is a query command and has no \*RST value.

**Example:** "SWE:POW:SPAC:MODE?"  
 'queries the sweep spacing for a level sweep at RF output.  
 Result: "LIN"  
 'linear spacing.

*RST value	Resolution	SCPI
-	-	Device-specific

**[SOURce<[1]|2>:]SWEep:POWer:STEP[:LOGarithmic] 0.01 ... 165 dB**

The command sets the step width factor for logarithmic sweeps. The next level value of a sweep is calculated (for START < STOP) using the following formula:

$$\text{New level} = \text{Old level} + \text{STEP:LOG} \times \text{Old level}$$

STEP:LOG therefore gives the fraction of the old level. The level is increased by this fraction for the next sweep step. Usually STEP:LOG is given in decibels, whereby the suffix dB must always be used.

The command is linked to the command :SWEep:POWer:POINTs for START < STOP as follows:

$$\text{POINTs} = ((\text{STOP} - \text{START}) / \text{STEP:LOG}) + 1$$

If STEP:LOG changes, the value of POINTs is adjusted. The START and STOP value is retained.

**Example:** "SWE:POW:STEP 10dB"  
 'sets the step width for logarithmic sweep spacing to 10 dB of the previous level in each instance (for a level sweep at RF output).

*RST value	Resolution	SCPI
1 dB	0.01 dB	Device-specific

**[SOURce<[1]|2>:]SWEep:RESet[:ALL]**

The command resets all active sweeps to the starting point.

The command triggers an event and therefore has no reset value.

**Example:** "SWE:RES"  
 'resets all active sweeps to the starting point.

*RST value	Resolution	SCPI
-	-	Device-specific

## SOURce-INPut Subsystem

The SOURce:INPut subsystem contains the commands for configuring the inputs for trigger, data and control signals.

A common trigger threshold and input impedance is effective for all trigger and control signal inputs. The settings influence the digital modulations, the generation of waveforms or multicarrier signals, and all digital standards. Irrespective of this, a common threshold and input impedance is effective for the serial and parallel data input. These data sources are available for digital modulation (**Custom Digital Modulation**).

The instrument trigger setting influences all sweeps and is effective in the List mode (Instrument Trigger).

Command	Parameters	Default unit	Remark
[SOURce:]INPut:DATA:IMPedance	G50   G1K		
[SOURce:]INPut:DATA:THReshold	0 ... 2 V		
[SOURce:]INPut:MODExt:IMPedance	G50   HIGH		
[SOURce:]INPut:TRIGger:BBANd:SLOPe	POSitive   NEGative		
[SOURce:]INPut:TRIGger:IMPedance	G50   G1K		
[SOURce:]INPut:TRIGger:LEVel	0 ... 2 V		
[SOURce:]INPut:TRIGger:SLOPe	POSitive   NEGative		

### [SOURce:]INPut:DATA:IMPedance G50 | G1K

The command sets the impedance of all data inputs.

The setting affects the serial data input DATA at the front of the instrument and the serial data inputs DATA at the AUX I/O interface at the rear of the instrument.

**Example:**        "INP:DATA:IMP G50"  
                  'all data inputs are set to 50 ohm to ground.'

*RST value	Resolution	SCPI
G1K	-	Device-specific

### [SOURce:]INPut:DATA:THReshold 0 ... 2 V

The command sets the high/low threshold of the data inputs in the baseband section. In the case of positive polarity, this threshold determines the point as of which a signal is high (active) or low (inactive).

The setting affects the serial data input DATA at the front of the instrument and the serial data inputs DATA at the AUX I/O interface at the rear of the instrument.

**Example:**        "INP:DATA:THR 1 V"  
                  'a high/low threshold of 1 volt is set at all data inputs of the baseband section.  
                  The signal is high (active) for a signal voltage of 1 volt and higher.'

*RST value	Resolution	SCPI
-	-	Device-specific

**[SOURce:]INPut:MODext:IMPedance HIGH | G50**

The command sets the impedance of the EXT MOD input.

This setting affects all analog modulations which use the external modulation source.

**Parameters:**     **HIGH**  
                           > 100 kOhm to ground

**G50**  
                           50 Ohm to ground

**Example:**         "INP:MOD:IMP G50"  
                           'the EXT MOD input is set to 50 ohm to ground.

*RST value	Resolution	SCPI
G50	-	Device-specific

**[SOURce:]INPut:TRIGger:BBANd:SLOPe POSitive | NEGative**

The command sets the active slope of an externally applied trigger signal at the **TRIGGER 1 | 2** connectors. The setting is effective for both connectors at the same time.

**Example:**         "INP:TRIG:BBAN:SLOP NEG"  
                           'the active slope of the external trigger signal at the TRIGGER 1 and 2 connector is the falling slope.

*RST value	Resolution	SCPI
POSitive	-	Device-specific

**[SOURce:]INPut:TRIGger:IMPedance G1K | G50**

The command sets the impedance of the trigger and control signal inputs.

The setting affects the TRIGGER 1 and 2, and CLOCK inputs (BNC connectors at the front of the instrument), and the CW, BURST, and LEV\_ATT inputs (AUX I/O interface at the rear of the instrument).

**Parameters:**     **G1K**  
                           1 kOhm to ground

**G50**  
                           50 Ohm to ground

**Example:**         "INP:TRIG:IMP G50"  
                           'all trigger and control signal inputs are set to 50 ohm to ground. This setting is recommended in the case of high clock rates.

*RST value	Resolution	SCPI
G1K	-	Device-specific

**[SOURce:]INPut:TRIGger:LEVel 0...2 V**

The command sets the high/low threshold of the trigger and control signal inputs in the baseband section. In the case of positive polarity, this threshold determines the point as of which a signal is high (active) or low (inactive).

The setting affects the TRIGGER 1 and 2, and CLOCK inputs (BNC connectors at the front of the instrument), and the CW, BURST, and LEV\_ATT inputs (AUX I/O interface at the rear of the instrument).

**Example:**           "INP:TRIG:LEV 1 V"  
                           'a high/low threshold of 1 volt is set at all trigger and control signal inputs of the baseband section. In the case of positive polarity, the signal is high (active) for a signal voltage of 1 volt and higher.

*RST value	Resolution	SCPI
1 V	-	Device-specific

**[SOURce:]INPut:TRIGger:SLOPe POSitive | NEGative**

The command sets the active slope of an externally applied trigger signal at the INST TRIG inputs.

**Example:**           "INP:TRIG:SLOP NEG"  
                           'the active slope of the external trigger signal at the INST TRIG inputs (BNC connector and AUX I/O interface) is the falling slope.

*RST value	Resolution	SCPI
POSitive	-	Device-specific

## SOURce-IQ Subsystem - I/Q Modulation

This subsystem contains the commands for checking the I/Q modulation.

I/Q modulation can be activated for both RF outputs in the case of two-path instruments with a second RF path, a second R&S Baseband Main Module, and one of the options R&S Baseband Generator, R&S External Baseband Input (if available) or R&S Noise Generator.

SOURce[1] = Path A

SOURce2 = Path B

Command	Parameters	Default unit	Remark
[SOURce<[1] 2>:]IQ:CREStfactor	0...30 dB	dB	
[SOURce<[1] 2>:]IQ:GAIN	DBM3   DB0   DB3   DB6		
[SOURce<[1] 2>:]IQ:IMPairment:IQRatio[:MAGNitude]	-12.0...12.0 PCT	PCT	
[SOURce<[1] 2>:]IQ:IMPairment:LEAKage:I	0 ... 50.0 PCT	PCT	
[SOURce<[1] 2>:]IQ:IMPairment:LEAKage:Q	0 ... 50.0 PCT	PCT	
[SOURce<[1] 2>:]IQ:IMPairment:QUADrature[:ANGLE]	-10.0...10.0 DEG	DEG	
[SOURce<[1] 2>:]IQ:IMPairment[:STATe]	ON   OFF		
[SOURce<[1] 2>:]IQ:SOURce	ANALog   BASeband		
[SOURce<[1] 2>:]IQ:STATe	ON   OFF		
[SOURce<[1] 2>:]IQ:SWAP[:STATe]	ON   OFF		
[SOURce<[1] 2>:]IQ:WBSTate	ON   OFF		

### [SOURce<[1]|2>:]IQ:CREStfactor 0...30 dB

This command specifies the crest factor of the external analog signal.

**Example:** "IQ:CRESt 10"  
'specifies a crest factor of 10 dB for the external analog signal.

*RST value	Resolution	SCPI
0 dB	0.01 dB	Device-specific

### [SOURce<[1]|2>:]IQ:GAIN DBM3 | DB0 | DB3 | DB6

This command specifies the baseband gain for the external analog wideband I/Q signal. Thus, the modulation of the I/Q modulator can be optimized for any measurement requirement. The gain settings for an internal or external baseband signal are performed with command

:SOURce:BB:IQGain.

**Parameters:** **DBM3**  
Activates 0 dB gain. With this setting, signal distortions are minimized.

**DB0**  
Activates 0 dB gain (standard settings).

**DB3**  
Activates 0 dB gain. This setting is recommended for 3GPP signals with very high adjacent channel power ratio (ACPR).

**DB6**  
Activates 0 dB gain. With this setting, signal noise is minimized.

**Example:** "IQ:SOUR ANAL"  
 'selects an external analog signal as the input signal for the I/Q modulator.  
 The signal must be applied at the inputs **I** and **Q**.

"IQ:GAIN DB0"  
 'sets gain 0 dB (standard).

*RST value	Resolution	SCPI
External Wideband: 3 dB	0.01 dB	Device-specific

#### [SOURce<[1]|2>:IQ:IMPairment:IQRatio[:MAGNitude] -12 ... +12 PCT

This command sets the ratio of I modulation to Q modulation (amplification "imbalance").

**Example:** "IQ:IMP:IQR 3 PCT"  
 'sets the imbalance to 3 percent.

*RST value	Resolution	SCPI
0 PCT	0.05 PCT	Device-specific

#### [SOURce<[1]|2>:IQ:IMPairment:LEAKage:I 0 ... 50 PCT

This command sets the carrier offset for the I-channel of the I/Q modulation.

**Example:** "IQ:IMP:LEAK:I 3 PCT"  
 'sets the leakage for the I-channel to 3 percent.

*RST value	Resolution	SCPI
0 PCT	0.05 PCT	Device-specific

#### [SOURce<[1]|2>:IQ:IMPairment:LEAKage:Q 0 ... 50 PCT

This command sets the carrier leakage amplitude for the Q-channel of the I/Q modulation.

**Example:** "IQ:IMP:LEAK:Q 3 PCT"  
 'sets the leakage for the Q-channel to 3 percent.

*RST value	Resolution	SCPI
0 PCT	0.05 PCT	Device-specific

#### [SOURce<[1]|2>:IQ:IMPairment:QUADrature[:ANGLE] -10.0 ... 10.0 DEG

This command sets the quadrature offset for the I/Q modulation.

**Example:** "IQ:IMP:QUAD:ANGL -5DEG"  
 'sets the quadrature offset to -5 degrees.

*RST value	Resolution	SCPI
0 DEG	0.02 DEG	Device-specific

[SOURce<[1]|2>:]IQ:IMPairment[:STATe] ON | OFF

The command activates (ON) and deactivates (OFF) the three impairment or correction values LEAKage, QUADrature and IQRatio for the analog signal in the I/Q modulator.

**Example:** "IQ:IMP OFF"  
'deactivates I/Q impairment.

*RST value	Resolution	SCPI
OFF	-	Device-specific

[SOURce<[1]|2>:]IQ:SOURce ANALog | BASeband

This command selects the input signal for the I/Q modulator. In case of two-path instruments, this selection is only available for Path A (SOURce [1]). The input signal for the I/Q modulator of Path B is always the internal baseband signal (BASeband)

**Example:** "IQ:SOUR ANAL"  
'selects an external analog signal as the input signal. The signal must be applied at the inputs I and Q.

*RST value	Resolution	Dependencies	SCPI
BASeband		Selecting ANALog (Wideband I/Q In) switches off: SOURce:AM:STATe OFF SOURce:BBAM:STATe OFF SOURce:BB:DM:STATe OFF SOURce:BB:<standard>:STATe OFF	Device-specific

[SOURce<[1]|2>:]IQ:STATe ON | OFF

This command activates and deactivates I/Q modulation.

**Example:** "IQ:STAT ON"  
'activates I/Q modulation.

*RST value	Resolution	SCPI
OFF	-	Device-specific

[SOURce<[1]|2>:]IQ:SWAP[:STATe] ON | OFF

When set to ON, this command swaps the I and Q channel.

**Example:** "IQ:SWAP ON"  
'swaps the I and Q channel.

*RST value	Resolution	SCPI
OFF	-	Device-specific

[SOURce<[1]|2>:]IQ:WBSTate ON | OFF

This command selects optimized setting for wideband modulation signals (>5 MHz) (State ON).

**Example:** "IQ:WBST ON"  
'activates optimized setting for wideband signals.

*RST value	Resolution	SCPI
OFF	-	Device-specific



## SOURce-IQ-OUTPut Subsystem - Differential Outputs

This subsystem contains the commands for configuring the differential output.

For two-path instruments the outputs can be assigned either to path A or to path B. Assignment is performed with command `SOURce:BB:IQOut:SOURce`.

Therefore, key word `SOURce` is without suffix in this sub system, it is optional and can be omitted.

For one-path instruments, the key word `SOURce` is optional and can be omitted.

Command	Parameters	Default unit	Remark
[SOURce:]IQ:OUTPut:BIAS:COUPling[:STATe]	ON   OFF		
[SOURce:]IQ:OUTPut:BIAS:I	-2.50 .. 2.50V	V	
[SOURce:]IQ:OUTPut:BIAS:OPTimization[:RF]:STATe	ON   OFF		
[SOURce:]IQ:OUTPut:BIAS:Q	-2.50 .. 2.50V	V	
[SOURce:]IQ:OUTPut:LEVEl	<numeric value>	V	Query only
[SOURce:]IQ:OUTPut:MODE	FIXed   VARiable		
[SOURce:]IQ:OUTPut:OFFSet:I	0 .. 600mV	V	
[SOURce:]IQ:OUTPut:OFFSet:Q	0 .. 600mV	V	
[SOURce:]IQ:OUTPut:TYPE	SINGle   DIFFerential		
[SOURce:]IQ:OUTPut[:ANALog]:POWEr:PEP:RESult	<numeric value>	V	Query only

### [SOURce:]IQ:OUTPut:BIAS:COUPling[:STATe] ON | OFF

This command activates/deactivates coupling of bias setting of the I-signal and Q-signal component. For activated coupling, the setting can be made for the I-signal component, it automatically applies to the Q-signal component as well.

For two-path instruments, the outputs are assigned with command `SOURce:BB:IQOut:SOURce`.

**Example:**           "`IQ:OUTP:BIAS:COUP ON`"  
                          'activates coupling of bias settings of the two components.

*RST value	Resolution	Dependencies	SCPI
ON		If coupling is activated, settings made for the I-signal component ( <code>SOUR:IQ:OUT:BIAS:I</code> ) automatically applies to the Q-signal ( <code>SOUR:IQ:OUT:BIAS:Q</code> )	Device-specific

### [SOURce:]IQ:OUTPut:BIAS:I -2.50 .. 2.50V

### [SOURce:]IQ:OUTPut:BIAS:Q -2.50 .. 2.50V

This command sets the amplifier bias.

The maximum overall voltage depends on the I/Q output type.

**Single ended:** `SOUR:IQ:OUTPut:LEV + SOUR:IQ:OUTP:BIAS:I|Q + SOUR:IQ:OUTP:OFFS:I|Q` is  $\leq 3.7$  volts.

**Differential:** `SOUR:(IQ:OUTPut:LEV/2) + SOUR:IQ:OUTP:BIAS:I|Q + SOUR:IQ:OUTP:OFFS:I|Q` is  $\leq 3.7$  volts.

For two-path instruments, the outputs are assigned with command `SOURce:BB:IQOut:SOURce`.

**Example:** "IQ:OUTP:BIAS:I 0.1 V"  
'sets a bias of 100 mV for the I-signal.

*RST value	Resolution	SCPI
0 V	2mV	Device-specific

**[SOURce:]IQ:OUTPut:BIAS:OPTimization[:RF]:STATe ON | OFF**

This command activates/deactivates optimization of level accuracy and imbalance for RF Output. Level accuracy and imbalance can be either optimized for RF output (active) or for differential outputs (not active).

For two-path instruments, the outputs are assigned with command `SOURce:BB:IQOut:SOURce`

**Example:** "IQ:OUTP:BIAS:OPT:STAT ON"  
'activates optimization for RF output.

*RST value	Resolution	SCPI
OFF		Device-specific

**[SOURce:]IQ:OUTPut:LEVEl <numeric value>**

This command sets the off-load voltage. The maximum overall voltage depends on the I/Q output type.

**Single ended:** `SOUR:IQ:OUTPut:LEV + SOUR:IQ:OUTP:BIAS:I|Q + SOUR:IQ:OUTP:OFFS:I|Q` is ≤ 3.7 volts.

**Differential:** `SOUR:(IQ:OUTPut:LEV/2) + SOUR:IQ:OUTP:BIAS:I|Q + SOUR:IQ:OUTP:OFFS:I|Q` is ≤ 3.7 volts.

The value range differs for the two output types.

**Differential output:** Value range: ± 2,0 Volt (corresponds to 0 ... 3.7 Volt open-circuit voltage). The maximum overall output voltage (**Level EMF + Bias + Offset**) is 3.7 volts.

**Single Ended:** Value range: ± 1,0 Volt (corresponds to 0 ... 2 Volt peak-peak).

For two-path instruments, the outputs are assigned with command `SOURce:BB:IQOut:SOURce`.

**Example:** "IQ:OUTP:LEV 2 V"  
'sets a off-load level of 2 V.

*RST value	Resolution	SCPI
1 V	0.001 V	Device-specific

**[SOURce:]IQ:OUTPut:LEVEl:RESult <numeric value>**

Displays the resulting output off-load voltage of both signal components at the rear panel.

For two-path instruments, the outputs are assigned with command `SOURce:BB:IQOut:SOURce`.

**Example:** "IQ:OUTP:LEV:RES?"  
'queries the resulting off-load power.

*RST value	Resolution	SCPI
0.000	0.001 V	Device-specific

**[SOURce:]IQ:OUTPut:MODE** FIXed | VARiable

This command selects the mode for setting the outputs.

For two-path instruments, the outputs are assigned with command `SOURce:BB:IQOut:SOURce`.

**Parameter:****FIXed**

The settings are fixed and cannot be changed.

(`IQ:OUTPut:BIAS:I|Q = 0V`, `IQ:OUTPut:OFFSet:I|Q = 0V` and `IQ:OUTPut:LEVel = 2V` (`TYPE DIFFerential`) or `1V` (`TYPE SINGle`)).

**VARiable**

The settings can be changed.

**Example:**

"`IQ:OUTP:MODE FIX`"

'the predefined settings are used.

*RST value	Resolution	Dependencies	SCPI
FIXed	-	Selection FIXed locks all <code>IQ:OUTPut</code> -commands except for <code>IQ:OUTPut:TYPE</code> and sets them to predefined values (see above).	Device-specific

**[SOURce:]IQ:OUTPut:OFFSet:I** 0.01 .. 1.0 V**[SOURce:]IQ:OUTPut:OFFSet:Q** 0.01 .. 1.0 V

This command sets an offset between the positive and the negative output.

The maximum overall voltage (`IQ:OUTPut:LEV/2`) + `SOUR:IQ:OUTP:BIAS:I|Q` + `SOUR:IQ:OUTP:OFFS:I|Q` is  $\leq 3.7$  volts. The command is only valid for output type `Differential` (`IQ:OUTP:TYPE DIFF`).

For two-path instruments, the outputs are assigned with command `SOURce:BB:IQOut:SOURce`.

**Example:**

"`IQ:OUTP:TYPE DIFF`"

'The I/Q-signal components are output differential.

"`IQ:OUTP:OFFS:I 0.05 V`"

'sets an offset of 50 mV for the I-signal.

*RST value	Resolution	SCPI
0 V	0.2 mV	Device-specific

**[SOURce:]IQ:OUTPut:TYPE** SINGle | DIFFerential

This command selects the output type.

For two-path instruments, the outputs are assigned with command `SOURce:BB:IQOut:SOURce`.

**Parameter:****DIFFerential**

The I/Q-signal components are output differential. A bias can be defined.

**Single Ended**

The I/Q-signal components are output single-ended.

**Example:**

"`IQ:OUTP:TYPE DIFF`"

'the I/Q-signal components are output differential.

*RST value	Resolution	SCPI
SINGle		Device-specific

## SOURce-IQ-OUTPut Subsystem - Digital I/Q Outputs

This subsystem contains the commands for configuring the digital I/Q output. The digital signal can be output with the aid of a standardized (LVDS) digital user interface. The digital output requires the option Digital I/Q Out (option R&S SMJ-B18).

Command	Parameters	Default unit	Remark
[SOURce:]IQ:OUTPut:DIGital:CDEvice			Query only
[SOURce:]IQ:OUTPut:DIGital:OFLow:HOLD:RESet			No query
[SOURce:]IQ:OUTPut:DIGital:OFLow:HOLD:STATe			Query only
[SOURce:]IQ:OUTPut:DIGital:OFLow:STATe			Query only
[SOURce:]IQ:OUTPut:DIGital:PON	OFF   UNCHanged		
[SOURce:]IQ:OUTPut:DIGital:POWer:LEVel	-90 ... 0 dBFS	dBFS	
[SOURce:]IQ:OUTPut:DIGital:POWer:PEP	-90 ... 0 dBFS	dBFS	
[SOURce:]IQ:OUTPut:DIGital:POWer:STEP[:INCRement]	0 ... 100 dB	dB	
[SOURce:]IQ:OUTPut:DIGital:POWer:STEP:MODE	DECimal   USER		
[SOURce:]IQ:OUTPut:POWer:VIA	PEP   LEVel		
[SOURce:]IQ:OUTPut:DIGital:SRATe	400 Hz ... 100 MHz	MHz	
[SOURce:]IQ:OUTPut:DIGital:SRATe:FIFO[:STATus]	OK   OFL   URUN		Query only
[SOURce:]IQ:OUTPut:DIGital:SRATe:SOUR	USER   DIN   DOUT		
[SOURce:]IQ:OUTPut:DIGital:STATe	ON   OFF		

### [SOURce:]IQ:OUTPut:DIGital:CDEvice?

**Digital Output only.**

This command indicates the ID of a connected R&S Instrument or R&S Device.

The command is a query command and therefore does not have an \*RST value.

**Example:** "IQ:OUTP:DIG:CDEV?"  
'queries the connected device ID.

*RST value	Resolution	SCPI
		Device-specific

### [SOURce:]IQ:OUTPut:DIGital:OFLow:HOLD:RESet

This command executes a reset of the overflow hold state and LED.

The command triggers an event and therefore has no query form and no \*RST value.

**Example:** "SOUR:IQ:OUTP:DIG:OFL:HOLD:RESet"  
'resets the overflow hold state.

*RST value	Resolution	SCPI
		Device-specific

**[SOURce:]IQ:OUTPut:DIGital:OFLow:HOLD:STATe?**

This command queries an overflow since the last reset. The overflow hold state can be reset via the **Reset** button next to the LED, or is reset automatically by starting a new signal generation or by setting new values to the output level.

The command is a query command and therefore does not have an \*RST value.

**Example:** "SOUR:IQ:OUTP:DIG:OFL:HOLD:STAT?"  
'queries the overflow state.

Response: "0" (no overflow)

*RST value	Resolution	SCPI
		Device-specific

**[SOURce:]IQ:OUTPut:DIGital:OFLow:STATe?**

This command queries the current overflow state of the output signal and indicates that the I/Q output signal is currently clipped.

The command is a query command and therefore does not have an \*RST value.

**Example:** "IQ:OUTP:DIG:OFL:STAT?"  
'queries the overflow state.

Response: "0" (no overflow).

*RST value	Resolution	SCPI
		Device-specific

**[SOURce:]IQ:OUTPut:DIGital:PON OFF | UNCHanged**

This command selects the state which the digital I/Q Output is to assume after the instrument is switched on.

For two-path instruments the power-on state can be set separately for each path.

**Examples:** "IQ:OUTP:DIG:PON OFF"  
'deactivates the output when the instrument is switched on.

"IQ:OUTP:DIG:PON UNCH"  
'sets the output to the status that was active before the last switch off.

*RST value	Resolution	Options	SCPI
OFF		B13 and B18	Device-specific

**[SOURce:]IQ:OUTPut:DIGital:POWer:LEV -90 dBFS .. 0 dBFS**

This command sets the rms level of the digital output signal. The level entry fields and the appropriate units (dBFS) are displayed in the status bar. The level display refers to both signal components ( $\sqrt{I^2+Q^2}$ ).

Value range: -90 dBFS .. 0 dBFS

**Example:** "IQ:OUTP:DIG:POW:LEV -10"  
'sets the output signal level to -10 dBFS.

*RST value	Resolution	Options	SCPI
0 dB	0.0001 dB	B13 and B18	Device-specific

**[SOURce:]IQ:OUTPut:DIGital:POWer:PEP -90 dBFS .. 0 dBFS**

This command sets the peak envelope power of the digital output signal (PEP). The level entry fields and the appropriate units (dBFS) are displayed in the status bar. The level display refers to both signal components ( $\sqrt{I^2+Q^2}$ ).

Value range: -90 .. 0 dBFS

**Example:** "IQ:OUTP:DIG:POW:PEP -10"  
'sets the signal output level to -10 dBFS.

*RST value	Resolution	Options	SCPI
0 dB	0.01 dB, 0.01e-5	B13 and B18	Device-specific

**[SOURce:]IQ:OUTPut:DIGital:POWer:STEP:[INCRement] 0 dB .. 100 dB**

The command sets the step width for the frequency setting if the frequency values UP/DOWN are used and variation mode SOUR:IQ:OUTP:DIG:POW:STEP:MODE USER is selected. The command is linked to **Variation Step** for manual operation, i.e. the command also sets the step width of the rotary knob for **Variation Active ON**.

For two-path instruments the step width can be set separately for each path.

**Example:** "SOUR:IQ:OUTP:ANAL:POW:STEP:INCR 50 mV"  
'sets the step width for the level setting to 50 mV.

*RST value	Resolution	Options	SCPI
1 dB		B13 and B18	Device-specific

**[SOURce:]IQ:OUTPut:DIGital:POWer:STEP:MODE DECimal | USER**

This command activates (USER) or deactivates (DECimal) the user-defined step width used when varying the level value with the level values UP/DOWN. The command is linked to setting **Variation Active** for manual operation, i.e. the command also activates/deactivates the user-defined step width used when varying the level value with the rotary knob.

For two-path instruments the step width can be set separately for each path.

**Example:** "IQ:OUTP:DIG:POW:STEP:MODE USER"  
'activates the step width for level variation with the rotary knob (manual operation) and with level values UP/DOWN (remote control).

*RST value	Resolution	Options	SCPI
DECimal	-	B13 and B18	Device-specific

**[SOURce:]IQ:OUTPut:POWer:VIA PEP | LEVel**

This command activates the selected I/Q output level entry fields of the currently selected signal path in the status bar.

**Parameter: PEP**  
The entry field of the parameter PEP is activated for level entry in the status bar.

**LEVel**  
The entry field of the parameter Level is activated for level entry in the status bar.

**Example:** "IQ:OUTP:POW:VIA PEP"  
'the I/Q-signal level is set via PEP for the signal of path A.

*RST value	Resolution	Options	SCPI
LEVel			Device-specific

**[SOURce:]IQ:OUTPut:DIGital:SRATe 400 Hz ... 100 MHz**

Using the sample rate source User the command sets the sample rate value of the output signal. This command is not active for external clock sources.  
Value range: 400 Hz .. 100 MHz

**Example:** "IQ:OUTP:DIG:SRAT:MODE USER"  
'with sample rate source User the internally generated clock reference signal is selected.

"IQ:OUTP:DIG:SRAT 100 MHz"  
'the sample rate for the output signal is set to 100 MHz.

*RST value	Resolution	Options	SCPI
100 MHz	0.01 Hz	B13 and B18	Device-specific

**[SOURce:]IQ:OUTPut:DIGital:SRATe:FIFO[:STATus]?**

This command queries the state of the signal transmission.  
The command is a query command and therefore does not have an \*RST value.

**Parameter: OK**  
Resampling is working properly.

**OFL = Overflow**  
The external sample rate frequency is too high which causes an overflow in signal transmission.

**URUN = Underrun**  
The external sample rate is too low which causes an underrun in signal transmission.

**Example:** "SOUR:BBIN:SRAT:FIFO:STATus?"  
'queries the FIFO Status of the sample rate.

*RST value	Resolution	SCPI
-	-	Device-specific

[SOURce:]IQ:OUTPut:DIGital:SRATe:SOURce USER | DOUT

This command selects the source for setting the sample rate of the digital I/Q output signal.

**Note:**

With a connected **R&S EX-IQ-Box** either the internal clock source (User defined) or an external clock (Digital I/Q In) can be selected in the settings dialog of the R&S EX-IQ-Box. Therefore, the sample rate source is only indicated in this field.

**Parameter:**

**USER**

The internally generated clock reference signal is used. The sample rate is calculated and displayed in the field **Value**.

**DOUT**

An external clock reference signal is used. The clock signal is directly fed in via pin **CLK2** of the digital output interface (option R&S SMJ-B18, Digital I/Q Out). The sample rate is displayed in the field **Value**.

**Example:**

"IQ:OUTP:DIG:SRAT:SOUR USER"

'the internally generated clock reference signal is selected.

*RST value	Resolution	Options	SCPI
USER	-	USER only with option B13 DOUT only with option B18	Device-specific

[SOURce:]IQ:OUTPut:DIGital:STATe ON | OFF

This command switches on and off the digital I/Q output signals.

**Example:**

"IQ:OUTP:DIG:STAT ON"

'the digital I/Q output signals of path A are activated.

*RST value	Resolution	Options	SCPI
OFF	-	B13 and B18	Device-specific



## STATus Subsystem

This system contains the commands for the status reporting system. \*RST has no effect on the status registers.

Queries return the current value of the respective register, which permits a check of the device status. A decimal value between 0 and 32767 ( $=2^{15}-1$ ) is returned.

The configuration commands set the respective register thus determining which status changes of the R&S Vector Signal Generator causes the status registers to be changed. A decimal value between 0 and 32767 ( $=2^{15}-1$ ) is set.

Command	Parameters	Default unit	Remark
STATus:OPERation:CONDition?			Query only
STATus:OPERation:ENABLE	0...32767		
STATus:OPERation[:EVENT]?			Query only
STATus:OPERation:NTRansition	0...32767		
STATus:OPERation:PTRansition	0...32767		
STATus:PRESet			No query
STATus:QUEStionable:CONDition?			Query only
STATus:QUEStionable:ENABLE	0...32767		
STATus:QUEStionable[:EVENT]?			Query only
STATus:QUEStionable:NTRansition	0...32767		
STATus:QUEStionable:PTRansition	0...32767		
STATus:QUEEue[:NEXT]?			Query only

### STATus:OPERation:CONDition?

The command queries the content of the CONDition part of the STATus:OPERation register. This part contains information on the action currently being performed in the instrument. The content is not deleted after being read out since it indicates the current hardware status.

**Example:**           "STAT:OPER:COND?"  
                          'queries the Status:Operation:Condition register.

*RST value	Resolution	SCPI
-	-	Compliant

### STATus:OPERation:ENABle

The command sets the bits of the ENABle part of the STATus:OPERation register. This setting determines which events of the Status-Event part are forwarded to the sum bit in the status byte. These events can be used for a service request.

**Example:**           "STAT:OPER:ENAB 32767"  
                          'all events are forwarded to the sum bit of the status byte.

*RST value	Resolution	SCPI
-	-	Compliant

**STATus:OPERation:EVENT?**

The command queries the content of the EVENT part of the STATus:OPERation register. This part contains information on the actions performed in the instrument since the last readout. The content of the EVENT part is deleted after being read out.

**Example:**           "STAT:OPER:EVENT?"  
                          'queries the STATus:OPERation:EVENT register.

*RST value	Resolution	SCPI
-	-	Compliant

**STATus:OPERation:PTRansition**

The command sets the bits of the PTRansition part of the STATus:OPERation register. If a bit is set, a transition from 0 to 1 in the condition part causes an entry to be made in the EVENT part of the register. A new event in the hardware is thus registered, e.g. the start of an adjustment.

**Example:**           "STAT:OPER:PTR 32767"  
                          'all transitions from 0 to 1 in the condition part of the Status:Operation register cause an entry to be made in the EVENT part.

*RST value	Resolution	SCPI
-	-	Compliant

**STATus:OPERation:NTRansition**

The command sets the bits of the NTRansition part of the STATus:OPERation register. If a bit is set, a transition from 1 to 0 in the condition part causes an entry to be made in the EVENT part of the register. The disappearance of an event in the hardware is thus registered, e.g. the end of an adjustment.

**Example:**           "STAT:OPER:NTR 0"  
                          'a transition from 1 to 0 in the condition part of the Status:Operation register does not cause an entry to be made in the EVENT part.

*RST value	Resolution	SCPI
-	-	Compliant

**STATus:PRESet**

The command resets the status registers. All PTRansition parts are set to FFFFh (32767), i.e. all transitions from 0 to 1 are detected. All NTRansition parts are set to 0, i.e. a transition from 1 to 0 in a CONDition bit is not detected. The ENABLE parts of STATus:OPERation and STATus:QUEStionable are set to 0, i.e. all events in these registers are not passed on.

The command triggers an event and therefore has no query form and no \*RST value.

**Example:**           "STAT:PRES"  
                          'resets the status registers.

*RST value	Resolution	SCPI
-	-	Compliant

**STATus:QUEStionable:EVENT?**

The command queries the content of the EVENT part of the STATus:QUEStionable register. This part contains information on the actions performed in the instrument since the last readout. The content of the EVENT part is deleted after being read out.

**Example:**           "STAT:OPER:EVEN?"  
                          'queries the Status:Questionable:Event register.

*RST value	Resolution	SCPI
-	-	Compliant

**STATus:QUEStionable:CONDition?**

The command queries the content of the CONDition part of the STATus:QUEStionable register. This part contains information on the action currently being performed in the instrument. The content is not deleted after being read out since it indicates the current hardware status.

**Example:**           "STAT:OPER:COND?"  
                          'queries the Status:Questionable:Condition register.

*RST value	Resolution	SCPI
-	-	Compliant

**STATus:QUEStionable:PTRansition**

The command sets the bits of the PTRansition part of the STATus:QUEStionable register. If a bit is set, a transition from 0 to 1 in the condition part causes an entry to be made in the EVENT part of the register.

**Example:**           "STAT:OPER:PTR 32767"  
                          'all transitions from 0 to 1 in the condition part of the Status:Questionable register cause an entry to be made in the EVENT part.

*RST value	Resolution	Options	SCPI
-	-		Compliant

**STATus:QUEStionable:NTRansition**

The command sets the bits of the NTRansition part of the STATus:QUEStionable register. If a bit is set, a transition from 1 to 0 in the condition part causes an entry to be made in the EVENT part of the register.

**Example:**           "STAT:OPER:NTR 0"  
                          'a transition from 1 to 0 in the condition part of the Status:Questionable register does not cause an entry to be made in the EVENT part.

*RST value	Resolution	SCPI
-	-	Compliant

**STATus:QUEStionable:ENABle**

The command sets the bits of the ENABle part of the STATus:QUEStionable register. This setting determines which events of the Status-Event part are enabled for the sum bit in the status byte. These events can be used for a service request.

**Example:**           "STAT:OPER:ENAB 1"  
                          'problems when performing an adjustment cause an entry to be made in the sum bit.

*RST value	Resolution	SCPI
-	-	Compliant

**STATus:QUEue[:NEXT]?**

The command queries the oldest entry in the error queue and then deletes it. Positive error numbers denote device-specific errors, and negative error numbers denote error messages defined by SCPI(see Chapter 9). If the error queue is empty, 0 ("No error") is returned. The command is identical to SYSTem:ERRor?.

**Example:**           "STAT:QUE?"  
                          'queries the oldest entry in the error queue.  
  
Response: "0, 'no error'"  
                          'no errors have occurred since the error queue was last read out.

*RST value	Resolution	SCPI
-	-	Compliant

## SYSTEM Subsystem

The SYSTEM subsystem contains a series of commands for general functions which do not directly affect signal generation.

Command	Parameters	Default unit	Remark
SYSTEM:BEEP:STATe	ON   OFF		
SYSTEM:COMMunicate:GPIB:LTERminator	EOI   STANdard		
SYSTEM:COMMunicate:GPIB[:SELF]:ADDRess	0...30		
SYSTEM:COMMunicate:NET:RESource	'string'		
SYSTEM:DATE	<year>,<month>,<day>		
SYSTEM:DISPlay:UPDate	ON   OFF		
SYSTEM:ERRor:ALL			Query only
SYSTEM:ERRor:CODE:ALL			Query only
SYSTEM:ERRor:CODE[:NEXT]?			Query only
SYSTEM:ERRor:COUNt?			Query only
SYSTEM:ERRor[:NEXT]?			Query only
SYSTEM:FPReset	See 'Preset Commands'		No query
SYSTEM:KLOCK	ON   OFF		
SYSTEM:PRESet			No query
SYSTEM:PROTect<n>[:STATe]	ON   OFF , password		
SYSTEM:SECurity[:STATe]	ON   OFF		
SYSTEM:SERRor?			Query only
SYSTEM:STARtup:COMPLete			Query only
SYSTEM:TIME	<hour>,<minute>,<second>		
SYSTEM:VERSIon?			Query only

### SYSTEM:BEEP:STATe ON | OFF

The command switches the key beep on or off.

**Example:** "SYSTEM:BEEP:STAT OFF"  
'no acoustic signal is output when a key on the front panel is pressed.'

*RST value	Resolution	SCPI
OFF	-	Compliant

### SYSTEM:COMMunicate:GPIB:LTERminator EOI | STANdard

The command sets the terminator recognition for remote control via the IEC/IEEE bus.

**Parameters:** EOI

The terminator must be sent together with the line message EOI (End of Line). This setting is recommended for binary block transmissions where a character could coincidentally have the value LF (Line Feed) but is not intended as the terminator. This setting must be selected for block data with undefined length.

**STANdard**

An LF (Line Feed) is recognized as the terminator regardless of whether it is sent with or without EOI.

**Example:** "SYST:COMM:GPIB:LTER EOI"  
 'only a character which is sent simultaneously with the line message EOI is accepted as the terminator.

*RST value	Resolution	SCPI
STANdard	-	Compliant

**SYSTem:COMMunicate:GPIB[:SELF]:ADDRess 1 ... 30**

The command sets the IEC/IEEE-bus address.

**Example:** "SYST:COMM:GPIB:ADDR 14"  
 'sets IEC/IEEE-bus address 14.

*RST value	Resolution	SCPI
28	-	Compliant

**SYSTem:COMMunicate:NET:RESource?**

The command queries the visa resource string. This string is used for remote control of the instrument.

The command is a query command and therefore has no \*RST value.

**Example:** SYST:COMM:NET:RES?  
 'queries the VISA resource string.

Response:  
 TCPIP::192.1.2.3::INSTR

*RST value	Resolution	SCPI
	-	Device-specific

**SYSTem:DATE <year>,<month>,<day>**

The command sets the date for the instrument-internal calendar.

**Example:** "SYST:DATE 2003,05,01"  
 'sets May 1, 2003.

*RST value	Resolution	SCPI
-	-	Compliant

**SYSTem:DISPlay:UPDate ON | OFF**

The command switches the update of the display on/off. A switchover from remote control to manual control always sets the status of the update of the display to ON.

**Example:** "SYST:DISP:UPD OFF"  
 'switches update of displayed parameter values off.

*RST value	Resolution	SCPI
-	-	Device-specific

**SYSTEM:ERRor:ALL?**

The command queries all entries in the error queue and then deletes them. Positive error numbers denote device-specific errors, and negative error numbers denote error messages defined by SCPI. If the error queue is empty, 0 ("No error") is returned.

The command is a query command and therefore has no \*RST value.

**Example:**       "SYST:ERR:ALL?"  
                  'queries all entries in the error queue.

Response: "0, 'no error'"  
           'no errors have occurred since the error queue was last read out.

*RST value	Resolution	SCPI
-	-	Compliant

**SYSTEM:ERRor:CODE:ALL?**

The command queries all entries in the error queue and then deletes them. Only the error numbers are returned and not the entire error text. Positive error numbers denote device-specific errors, and negative error numbers denote error messages defined by SCPI (see chapter 9, section "[Error Messages](#)"). If the error queue is empty, 0 ("No error") is returned.

The command is a query command and therefore has no \*RST value.

**Example:**       "SYST:ERR:CODE:ALL?"  
                  'queries all entries in the error queue.

Response: "0"  
           'no errors have occurred since the error queue was last read out.

*RST value	Resolution	SCPI
-	-	Compliant

**SYSTEM:ERRor:CODE[:NEXT]?**

The command queries the oldest entry in the error queue and then deletes it. Only the error number is returned and not the entire error text. Positive error numbers denote device-specific errors, and negative error numbers denote error messages defined by SCPI (see chapter 9, section "[Error Messages](#)"). If the error queue is empty, 0 is returned.

The command is a query command and therefore has no \*RST value.

**Example:**       "SYST:ERR:CODE?"  
                  'queries the oldest entry in the error queue.

Response: "0"  
           'no errors have occurred since the error queue was last read out.

*RST value	Resolution	SCPI
-	-	Compliant

**SYSTem:ERRor:COUNT?**

The command queries the number of entries in the error queue. If the error queue is empty, '0' is returned.

The command is a query command and therefore has no \*RST value.

**Example:** "SYST:ERR:COUN?"  
 'queries the number of entries in the error queue.  
 Response: "1"  
 'one error has occurred since the error queue was last read out.

*RST value	Resolution	SCPI
-	-	Compliant

**SYSTem:ERRor[:NEXT]?**

The command queries the oldest entry in the error queue and then deletes it. Positive error numbers denote device-specific errors, and negative error numbers denote error messages defined by SCPI (see Chapter 9). If the error queue is empty, 0 ("No error") is returned. The command is identical to the command STATus:QUEue:NEXT?.

The command is a query command and therefore has no \*RST value.

**Example:** "SYST:ERR?"  
 'queries the oldest entry in the error queue.  
 Response: "0, 'no error'"  
 'no errors have occurred since the error queue was last read out.

*RST value	Resolution	SCPI
-	-	Compliant

**SYSTem:KLOCK ON | OFF**

The command (Keyboard LOCK) disables the front panel keyboard of the R&S Vector Signal Generator including the LOCAL key, or enables it again (OFF).

**Example:** "SYST:KLOC ON"  
 'activates the keyboard lock. The keyboard cannot be operated again until it has been enabled with SYST:KLOC OFF.

*RST value	Resolution	SCPI
OFF	-	Compliant

**SYSTem:PRESet**

The command triggers an instrument reset. It has the same effect as the PRESET key on the front panel and the \*RST command.

The command triggers an event and therefore has no \*RST value and no query form.

**Example:** "SYST:PRES"  
 'all instrument settings (also those that are not currently active) are reset to their default values.

*RST value	Resolution	SCPI
-	-	Compliant



**SYSTEM:PROTECT<n>[:STATE] ON | OFF, password**

The command activates and deactivates the specified protection level. There are several protection levels which disable specific service functions (authorized personnel of R&S Service Departments only). These levels are identified by the suffix under PROTECT.

The respective functions are disabled when the protection level is activated. No password is required for activation. A password must be entered to deactivate the protection level. The password for the first level is 123456. This protection level can be used to lock-out internal adjustments.

The command triggers an event and therefore has no \*RST value and no query form.

**Example:** "SYST:PROT1 ON"  
'activates protection level 1. Internal adjustments are only possible after deactivating the lock-out.

"SYST:PROT1 OFF, 123456"  
'deactivates protection level 1. Internal adjustments are enabled again.

*RST value	Resolution	SCPI
-	-	Compliant

**SYSTEM:SERRor?**

This command returns a list of all errors existing at the time when the query is started. This list corresponds to the display on the info page under manual control.

The command is a query command and therefore has no \*RST value.

**Example:** "SYST:SERR?"  
'queries all errors existing in the error queue.

Response: "-221, 'Settings conflict', 153, 'Input voltage out of range'"  
'the two returned errors have occurred since the error queue was last queried.

*RST value	Resolution	SCPI
-	-	Device-specific

**SYSTEM:STARtup:COMPLete?**

The command queries if the startup of the instrument is completed.

This command is a query and therefore has no \*RST value.

**Example:** SYST:STAR:COMP?

Response: 1  
'the startup of the instrument is completed.

*RST value	Resolution	Options	SCPI
	-		

**SYSTem:TIME 0...23,0...59,0...59**

The command sets the time for the instrument-internal clock.

**Example:**           "SYST:TIME 12,0,0"  
                          'sets the time to precisely 12 pm.

*RST value	Resolution	SCPI
-	-	Compliant

**SYSTem:VERSion?**

The command queries the SCPI version with which the instrument complies.

The command is a query command and therefore has no \*RST value.

**Example:**           "SYST:VERS?"  
                          'queries the SCPI version.

Response: 1996  
                          'the instrument complies with the version from 1996.

*RST value	Resolution	SCPI
-	-	Compliant

## TEST Subsystem

The TEST system contains the commands for performing the routines as well as for direct manipulation of the hardware assemblies (:TEST:DIRect). The self tests return a "0" if the test is performed successfully, otherwise a value other than "0" is returned. None of the commands of this system have an \*RST value.

In the case of two-path instruments, the numerical suffix under TEST distinguishes between RF Path A and RF Path B:

TEST[1] = RF Path A

TEST2 = RF Path B

### NOTICE Improper use could destroy the assembly!

The respective hardware assembly responds directly to the :TEST:DIRect command; any safety mechanisms are bypassed. The command is used for servicing purposes and should not be applied by the user.

Command	Parameters	Default unit	Remark
TEST:BB:CONNection	0 if succeeded, 1 if failed		Query only
TEST<[1] 2>:BBOut:LRATe	66 ... 100 MHz	MHz	
TEST<[1] 2>:BBOut:TTEST[:STATe]	ON   OFF   1   0		Query only
TEST:CONNector:AUXio	-		Query only
TEST:CONNector:BNC	-		Query only
TEST<1 2>:DIRect	'SSYN'   'IQOP3'   'IQOP6'   'SATT3'   'SATT6'   'DIRECTLAST', subaddress, hex data string		

### TEST:BB:CONNection?

The command performs a connection test on each of the internal digital baseband links. This implies all installed options as baseband inputs, motherboard, universal coding generators, fading simulators, and baseband outputs.

**Example:** "TEST:BB:CONNection?"

Response: "0" on success, "1" on fail

*RST value	Resolution	SCPI
-	-	Device-specific

### TEST<[1]|2>:BBOut:LRATe 66 ... 100 MHz

The command sets the interface speed.

The **External LVDS Test** is used to check the correct data transmission of the digital baseband outputs (BBOUT).

An external cable connection is needed to perform this test successfully. An output must be connected to an input with the digital I/Q cable. Always an input/output pair is tested together. The input and the output can be on the same instrument, or alternatively on two different instruments. Given an arbitrary cable connection, the appropriate Tx test can be activated with different interface speeds (LVDS rate).

On the connected input, this test sequence is received and can be compared with the expected test signal.

**Example:**           "TEST:BBOut:LRATe 90MHZ"  
                       'sets the LVDS interface rate to 90 MHz

*RST value	Resolution	SCPI
-	-	Device-specific

**TEST<[1]|2>:BBOut:TTEST[:STATe] ON | OFF**

This command activates the transmission of a known pseudo-random sequence (**On**).

**Example:**           "TEST:BBO:TTEST:STAT ON"  
                       'starts the transmission of a signal test sequence .

*RST value	Resolution	SCPI
-	-	Device-specific

**TEST:CONNector:AUXio?**

The command triggers a test of the AUX IQ interface (see Service Manual Instrument, chapter 1, "Performance Test"). This function is only available via remote control.

**Example:**           "TEST:CONN:AUX?"

*RST value	Resolution	SCPI
-	-	Device-specific

**TEST:CONNector:BNC?**

The command triggers a test of the BNC connectors of the instrument (see Service Manual Instrument, chapter 1, "Performance Test"). This function is only available via remote control.

**Example:**           "TEST:CONN:BNC?"

*RST value	Resolution	SCPI
-	-	Device-specific

**TEST<1|2>:DIRect "SSYN" | 'IQOP3' | 'IQOP6' | 'SATT3' | 'SATT6' | 'DIRECTLAST', subaddress, hex data string**

The respective hardware assembly responds directly to the command; any safety mechanisms are bypassed. This function is only available via remote control.

**Example:**           "TEST:DIR 'SSYN',0,#H12345678"  
                       "TEST:DIR? 'SSYN',0"

Response:  
                       '#H12345678

*RST value	Resolution	SCPI
-	-	Device-specific

## TRIGger Subsystem

The TRIGger system contains the commands for selecting the trigger source for the RF and LF sweep.

The trigger input connectors are configured in the SOURce:INPut subsystem.

In the case of two-path instruments, the suffix determines the path for which the trigger setting is effective:

Path A = TRIGger[1]

Path B = TRIGger2

In addition, the LF output is activated with TRIGger0.

The trigger system of the R&S Vector Signal Generator is a simplified implementation of the SCPI trigger system. The TRIGger system differs from the SCPI system as follows:

- No INITiate command; the instrument behaves as if INITiate:CONTinuous ON were set.
- Under TRIGger several sweep subsystems exist.

Other commands associated with the trigger system of the R&S Vector Signal Generator can be found in the modulation and RF signal subsystems.

Command	Parameters	Default unit	Remark
TRIGger0[:SWEep]:SOURce	AUTO   IMMEDIATE   SINGLE   BUS   EXTERNAL		
TRIGger<[1]]2>:FSWEEP[:IMMEDIATE]			No query
TRIGger<[1]]2>:FSWEEP:SOURce	AUTO   IMMEDIATE   SINGLE   BUS   EXTERNAL		
TRIGger<[1]]2>:LIST[:IMMEDIATE]			No query
TRIGger<[1]]2>:PSWEEP[:IMMEDIATE]			No query
TRIGger<[1]]2>:PSWEEP:SOURce	AUTO   IMMEDIATE   SINGLE   BUS   EXTERNAL		
TRIGger<[1]]2>[:SWEep][:IMMEDIATE]			No query
TRIGger<[1]]2>[:SWEep]:SOURce	AUTO   IMMEDIATE   SINGLE   BUS   EXTERNAL		

### TRIGger0[:SWEep]:SOURce AUTO | IMMEDIATE | SINGLE | EXTERNAL|BUS

The command sets the trigger source for the LF sweep. The trigger is triggered by the command :SOURce:LFOutput:SWEep[:FREQuency]EXECute.

The names of the parameters correspond directly to the various settings under manual control. SCPI uses other names for the parameters; these names are also accepted by the instrument. The SCPI names should be used if compatibility is an important consideration. An overview of the various names is given in the following table:

R&S name	SCPI name	Command under manual control
AUTO	IMMEDIATE	<b>Auto</b> mode
SINGLE	BUS	<b>Single</b> mode.
EXTERNAL	EXTERNAL	<b>Ext Single</b> and <b>Ext Step</b> mode. The command LFO:SWEep:MODE is used to select between the two sweep modes.

**Parameters:**     **AUTO | IMMEDIATE**  
 The trigger is free-running, i.e. the trigger condition is fulfilled continuously. As soon as one sweep is finished, the next sweep is started.

**SINGLE**  
 One complete sweep cycle is triggered by the IEC/IEEE-bus commands `SOURCE:LFOutput:SWEep:FREQuency:EXEC` or `*TRG`. The mode has to be set to `AUTO` (`:SOURCE:LFOutput:SWEep:FREQuency:MODE AUTO`).

**EXTERNAL**  
 The sweep is triggered externally via the INST TRIG connector.

**Example:**        `"TRIG0:SOUR EXT"`  
 'selects triggering with an external trigger. The trigger is input via the INST TRIG connector.

*RST value	Resolution	SCPI
SINGLE	-	Device-specific

**TRIGger<[1]|2>:FSWep[:IMMEDIATE]**

The command immediately starts an RF frequency sweep. The sweep to be executed depends on the respective MODE setting (`SOURCE:SWEep:FREQuency:MODE SING`). The command corresponds to the manual-control command **Execute Trigger**.

This command triggers an event and therefore has no \*RST value.

**Example:**        `"SWE:FREQ:MODE SING"`  
 'sets the Single trigger mode, i.e. a trigger starts a single sweep.  
`"TRIG:FSW"`  
 'starts a single RF frequency sweep.

*RST value	Resolution	SCPI
-	-	Device-specific

**TRIGger<[1]|2>:FSWep:SOURce AUTO|IMMEDIATE | SINGLE | EXTERNAL|BUS**

The command sets the trigger source for the RF frequency sweep.

The names of the parameters correspond directly to the various settings under manual control. SCPI uses other names for the parameters; these names are also accepted by the instrument. The SCPI names should be used if compatibility is an important consideration. An overview of the various names is given in the following table:

R&S name	SCPI name	Command under manual control
AUTO	IMMEDIATE	<b>Auto</b> mode
SINGLE	BUS	<b>Single</b> mode.
EXTERNAL	EXTERNAL	<b>Ext Single</b> and <b>Ext Step</b> mode. The command <code>:SWEep:FREQ:MODE</code> is used to select between the two sweep modes.

**Parameters:**     **AUTO | IMMEDIATE**  
 The trigger is free-running, i.e. the trigger condition is fulfilled continuously. As soon as one sweep is finished, the next sweep is started.

**SINGLE**  
 One complete sweep cycle is triggered by the IEC/IEEE-bus commands `SOURCE:SWEep:FREQuency:EXEC` or `*TRG`. The mode has to be set to `AUTO` (`:SOURCE:SWEep:FREQuency:MODE AUTO`).

**EXTERNAL**  
 The sweep is triggered externally via the INST TRIG connector.

**Example:**        `"TRIG:FSW:SOUR EXT"`  
 'selects triggering with an external trigger. The trigger is input via the TRIGGER 1 connector.

*RST value	Resolution	SCPI
SINGLE	-	Device-specific

**TRIGger<[1]|2>:LIST[:IMMEDIATE]**

The command immediately starts the processing of a list in LIST mode. It corresponds to the manual-control command **Execute Trigger**.

This command triggers an event and therefore has no \*RST value.

**Example:**        `"SOUR:LIST "LIST1"`  
 'selects the list.  
`"SOUR:LIST:DWEL 5 ms"`  
 'sets the dwell time to 5 ms.  
`"TRIG:LIST"`  
 'starts processing of the selected list.

*RST value	Resolution	SCPI
-	-	Device-specific

**TRIGger<[1]|2>:PSWEEP[:IMMEDIATE]**

The command immediately starts an RF level sweep. The sweep to be executed depends on the set sweep mode (`:SOURCE:SWEep:POWer:MODE`). The command corresponds to the manual-control command **Execute Trigger**.

This command triggers an event and therefore has no \*RST value.

**Example:**        `"SWE:POW:MODE STEP"`  
 'sets the STEP trigger mode, i.e. a trigger starts the sweep initially, and then the sweep is generated continuously.  
`"TRIG:PSW"`  
 'starts the continuous generation of the RF level sweep at output A.

*RST value	Resolution	SCPI
-	-	Device-specific

**TRIGger<[1]|2>:PSWEEP:SOURce** AUTO|IMMediate | SINGle | EXTernal|BUS

The command sets the trigger source for the RF level sweep.

The names of the parameters correspond directly to the various settings under manual control. SCPI uses other names for the parameters; these names are also accepted by the instrument. The SCPI names should be used if compatibility is an important consideration. An overview of the various names is given in the following table:

R&S name	SCPI name	Command under manual control
AUTO	IMMediate	<b>Auto</b> mode
SINGle	BUS	<b>Single</b> mode.
EXTernal	EXTernal	<b>Ext Single</b> and <b>Ext Step</b> mode. The command :SWEep:POW:MODE is used to select between the two sweep modes.

**Parameters:**      **AUTO | IMMediate**

The trigger is free-running, i.e. the trigger condition is fulfilled continuously. As soon as one sweep is finished, the next sweep is started.

**SINGle**

One complete sweep cycle is triggered by the IEC/IEEE-bus commands SOURce:SWEep:LEVel:EXEC or \*TRG. The mode has to be set to AUTO (:SOURce:SWEep:LEVel:MODE AUTO).

**EXTernal**

The sweep is triggered externally via the INST TRIG connector.

**Example:**

"TRIG:PSW:SOUR EXT"  
'selects triggering with an external trigger. The trigger is input via the INST TRIG connector.

*RST value	Resolution	SCPI
SINGle	-	Device-specific

**TRIGger<[1]|2>[:SWEep][:IMMediate]**

The command starts all sweeps which are activated for the respective path. The command starts all sweeps which are activated.

The sweep to be executed depends on the respective MODE setting (:SOUR:SWEep:POW|FREQ:MODE and :SOUR:LFO:SWEep[:FREQ]:MODE).

The command corresponds to the manual-control command **Execute Trigger**.

This command triggers an event and therefore has no \*RST value.

**Example:**

"TRIG"  
'starts all active sweeps.

*RST value	Resolution	SCPI
-	-	Device-specific



**TRIGger<[1]2>:SWEep:SOURce** AUTO|IMMediate | SINGle | EXTernal|BUS

The command sets the trigger source for all sweeps.

The names of the parameters correspond directly to the various settings under manual control. SCPI uses other names for the parameters; these names are also accepted by the instrument. The SCPI names should be used if compatibility is an important consideration.

An overview of the various names is given in the following table:

R&S name	SCPI name	Command under manual control
AUTO	IMMediate	MODE AUTO
SINGle	BUS	MODE SINGLE
EXTernal	EXTernal	MODE EXT TRIG SINGLE or EXT TRIG STEP

**Parameters:**      **AUTO | IMMediate**

The trigger is free-running, i.e. the trigger condition is fulfilled continuously. As soon as one sweep is finished, the next sweep is started.

**SINGle**

One complete sweep cycle is triggered by the IEC/IEEE-bus commands `SOURce:SWEep:POWer | FREQuency:EXEC` or `*TRG`. The mode has to be set to `AUTO` (`:SOURce:SWEep:POWer | FREQuency:MODE AUTO`).

**EXTernal**

The sweep is triggered externally via the TRIGGER connectors.

**Example:**      `"TRIG:SWE:SOUR EXT"`

'selects triggering with an external trigger. The trigger is input via the TRIGGER 1 connector.

*RST value	Resolution	SCPI
SINGle	-	Device-specific

## UNIT Subsystem

The UNIT subsystem contains the commands specifying which units are valid if no unit is indicated in a command. These settings are valid for the entire instrument.

Command	Parameters	Default unit	Remark
UNIT:ANGLE	DEG   RAD		
UNIT:POW	V   DBM		

### UNIT:ANGLE DEG | RAD

The command defines the default unit for angles. It is valid for all commands which determine angle values. It does not influence the manual control parameter unit and the display.

**Example:**           "UNIT:ANGL DEG"  
                          'sets default unit DEG for all commands which determine angle values.

*RST value	Resolution	SCPI
RAD	-	Compliant

### UNIT:POW V | DBM

The command defines the default unit for power. It is valid for all commands which determine power values. It does not influence the manual control parameter unit and the display.

**Example:**           "UNIT:POW V"  
                          'sets default unit V for all commands which determine power values.

*RST value	Resolution	Options	SCPI
DBM	-		Compliant

## Contents Chapter 8 - Maintenance and Interfaces

<b>Maintenance and Remote Control Interfaces .....</b>	<b>8.1</b>
Introduction - Maintenance and Interfaces .....	8.1
Maintenance .....	8.1
Cleaning the Outside and Storing .....	8.1
Hardware Interfaces .....	8.2
IEC/IEEE Bus Interface .....	8.2
LAN Connector .....	8.5
USB Connection (USB and USB IN).....	8.8
Monitor Connector (MONITOR) .....	8.8
BERT Connector .....	8.8



# 8 Maintenance and Remote Control Interfaces

## Introduction - Maintenance and Interfaces

The following chapter contains information on the maintenance of the signal generator and a description of the remote control interfaces.

Please follow the instructions in the service manual when exchanging modules or ordering spares. The order no. for spare parts can be found in the service manual.

The address of our support center and a list of all Rohde & Schwarz service centers can be found at the beginning of the printed manual.

The service manual includes further information particularly on troubleshooting, repair and exchange of modules.

## Maintenance

The instrument does not need a periodic maintenance. What is necessary is essentially the cleaning of the instrument. However, it is recommended to check the rated data from time to time.

### Cleaning the Outside and Storing

The outside of the instrument is suitably cleaned using a soft, line-free dust cloth. Make sure that vents are not obstructed.

---

**NOTICE****Instrument damage caused by cleaning agents!**

Cleaning agents contain substances that may damage the instrument, e.g. solvent-containing cleaning agents may damage the front panel labeling or plastic parts.

Never use cleaning agents such as solvents (thinners, acetone, etc), acids, bases, or other substances.

The outside of the instrument is suitably cleaned using a soft, line-free dust cloth.

---

The storage temperature range of the instrument is given in the data sheet. If the instrument is to be stored for a longer period of time, it must be protected against dust.

The original packing should be used, particularly the protective covers at the front and rear, when the instrument is to be transported or dispatched. If the original packing is no longer available, use a sturdy cardboard box of suitable size and carefully wrap the instrument to protect it against mechanical damage.

## Hardware Interfaces

The following section describes the remote control interfaces of the signal generator and the pin assignment of the monitor connector. The AUX IO interface is described with the associated configuration menu in chapter 4, section "[User Marker - AUX-IO - Setup-Environment-Global...Settings](#)". All other interfaces are described in chapter 1, sections "[Legend for Front Panel View](#)" and "[Legend for Rear Panel View](#)". For specifications refer to the data sheet.

### IEC/IEEE Bus Interface

The standard instrument is equipped with an IEC/IEEE bus connector. An IEEE 488 interface connector is located on the rear panel. An external controller for remote control of the instrument can be connected via the IEEE 488 interface connector using a shielded cable.

#### Interface Characteristics

- 8-bit parallel data transfer
- bi-directional data transfer
- three-line handshake
- high data transfer rate
- up to 15 instruments can be connected
- maximal length of the interconnecting cables 15 m (single connection, 2 m)
- wired-OR connection if several instruments are connected in parallel.

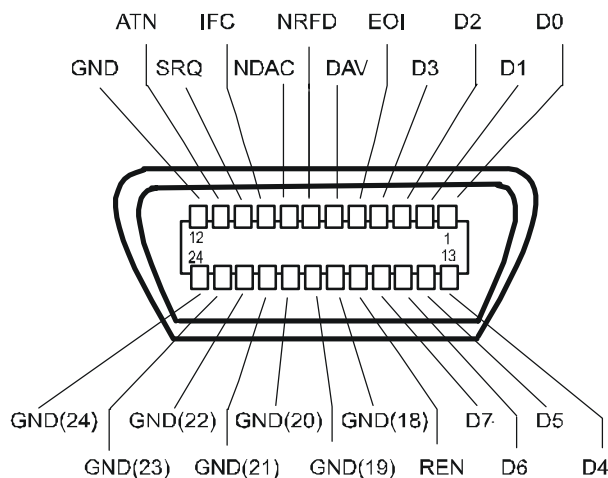

Figure 8-1 Pin assignment of IEC/IEEE-Bus interface

## Bus Lines

### 1. Data bus with 8 lines D0 to D7.

The transmission is bit-parallel and byte-serial in the ASCII/ISO code. D0 is the least significant bit, D7 the most significant bit.

### 2. Control bus with 5 lines

<b>IFC</b> (Interface Clear)	active LOW resets the interfaces of the instruments connected to the default setting.
<b>ATN</b> (Attention)	active LOW signals the transmission of interface messages. inactive HIGH signals the transmission of device messages.
<b>SRQ</b> (Service Request)	active LOW enables the connected device to send a service request to the controller.
<b>REN</b> (Remote Enable)	active LOW permits switchover to remote control.
<b>EOI</b> (End or Identify)	has two functions in connection with ATN: ATN = HIGH active LOW marks the end of data transmission. ATN = LOW active LOW triggers a parallel poll.

### 3. Handshake bus with three lines

<b>DAV</b> (Data Valid)	active LOW signals a valid data byte on the data bus.
<b>NRFD</b> (Not Ready For Data)	active LOW signals that one of the connected devices is not ready for data transfer.
<b>NDAC</b> (Not Data Accepted)	active LOW signals that the instrument connected is accepting the data on the data bus.

## IEC/IEEE-Bus Interface Functions

Instruments which can be remote controlled via the IEC/IEEE bus can be equipped with different interface functions. The following table lists the interface functions appropriate for the instrument.

Table 8-1 IEC/IEEE Bus Interface functions

Control character	Interface function
SH1	Handshake source function (source handshake), full capability
AH1	Handshake sink function (acceptor handshake), full capability
L4	Listener function, full capability, unaddress if MTA.
T6	Talker function, full capability, ability to respond to serial poll, unaddress if MLA
SR1	Service request function (Service Request), full capability
PP1	Parallel poll function, full capability
RL1	Remote/Local switch over function, full capability
DC1	Reset function (Device Clear), full capability
DT1	Trigger function (Device Trigger), full capability
C0	No controller function

## IEC/IEEE Bus Messages

Interface messages are transferred on the data lines of the IEC/IEEE bus when the "ATN" control line is active (LOW). They are used for communication between controller and instruments and can only be sent by the controller which currently has control of the IEC/IEEE bus.

### Universal Commands

The universal commands are encoded 10 - 1F hex. They affect all instruments connected to the bus without addressing.

Table 8-2 Universal Commands

Command	VISUAL BASIC command	Effect on the instrument
DCL (Device Clear)	IBCMD (controller%, CHR\$(20))	Aborts the processing of the commands just received and sets the command processing software to a defined initial state. Does not change the instrument settings..
IFC (Interface Clear)	IBSIC (controller%)	Resets the interfaces to the default setting.
LLO (Local Lockout)	IBCMD (controller%, CHR\$(17))	Locks switchover from remote control to manual operation by means of the front panel keys
SPE (Serial Poll Enable)	IBCMD (controller%, CHR\$(24))	Ready for serial poll.
SPD (Serial Poll Disable)	IBCMD (controller%, CHR\$(25))	End of serial poll.
PPU (Parallel Poll Unconfigure)	IBCMD (controller%, CHR\$(21))	End of the parallel-poll state.

### Addressed Commands

The addressed commands are encoded 00 - 0F hex. They are only effective for instruments addressed as listeners.

Table 8-3 Addressed Commands

Command	VISUAL BASIC Command	Effect on the instrument
SDC (Selected Device Clear)	IBCLR (device%)	Aborts the processing of the commands just received and sets the command processing software to a defined initial state. Does not change the instrument setting.
GET (Group Execute Trigger)	IBTRG (device%)	Triggers a previously active device function (e.g. a sweep). The effect of the command is the same as with that of a pulse at the external trigger signal input.
GTL (Go to Local)	IBLOC (device%)	Transition to the "Local" state (manual operation).
PPC (Parallel Poll Configure)	IBPPC (device%, data%)	Configures instrument for parallel poll. Additionally, the VISUAL BASIC command executes PPE/PPD.



## LAN Connector

The unit is equipped with an LAN interface as standard. The LAN connector is at the rear of the instrument. Provided the appropriate rights have been assigned by the network administrator, files can be transmitted via the network, and network resources, e.g. a network folders, can be used. The instrument can also be remote controlled and manually operated in the network. It is connected by means of a commercial RJ45 cable.

The TCP/IP network protocol and the associated network services are preconfigured. TCP/IP ensures connection-oriented communication, where the order of the exchanged messages is adhered to and interrupted links are identified. With this protocol, messages cannot be lost.

Connection of the R&S Signal Generator is described in Chapter 1, section "[Connection to the Network](#)", remote control via Ethernet in chapter 5, section "[Remote Control via LAN Interface](#)", page 5.5. The architecture of a LAN remote-control connection is described in detail in the following.

Remote control of an instrument via a network is based on standardized protocols which follow the OSI reference model (see Fig. below).

Application	SCPI	SCPI [3]
Presentation	XDR (VXI-11)	RFC 1014 [1,2]
Session	ONC-RPC	RFC 1057
Transport	TCP / UDP	RFC 793
Network	IP	RFC 791
Data Link	Ethernet/802.3	8802-3
Physical	802.3/10BASE-T	8802-3

Fig. 8-2 Example for LAN remote control based on the OSI reference model

Based on TCP/UDP, messages between the controller and the instrument are exchanged via open network computing (ONC) - remote procedure calls (RPC). With XDR, legal RPC messages are known as VXI-11 standard. Based on this standard, messages are exchanged between the controller and the instrument. The messages are identical with SCPI commands. They can be organized in four groups: program messages (control command to the instrument), response messages (values returned by the instrument), service request (spontaneous queries of the instrument) and low-level control messages (interface messages).

A VXI-11 link between a controller and an instrument uses three channels: a core, abort and interrupt channel. Instrument control is mainly performed on the core channel (program, response and low-level control messages). The abort channel is used for immediate abort of the core channel; the interrupt channel transmits spontaneous service requests of the instrument. Link setup itself is very complex. For more details refer to the VXI-11 specification ("TCP/IP Instrument Protocol Specification VXI-11, Revision 1.0 VMEbus Extensions for Instrumentation, VXIbus", and "TCP/IP-IEEE 488.2 Instrument Interface Specification VXI-11.3, Draft 0.3 VMEbus Extensions for Instrumentation, VXIbus").

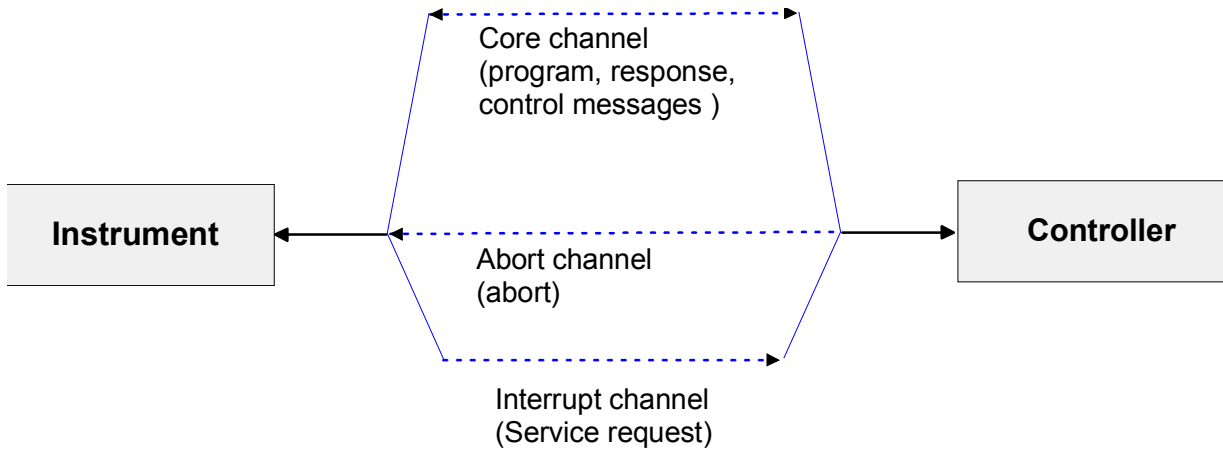

Fig. 8-3 VXI-11 channels between instrument and controller

The number of controllers that can address an instrument is practically unlimited in the network. In the instrument, the individual controllers are clearly distinguished. This distinction continues up to the application level in the controller, i.e. two applications on a PC are identified by the instrument as two different controllers.

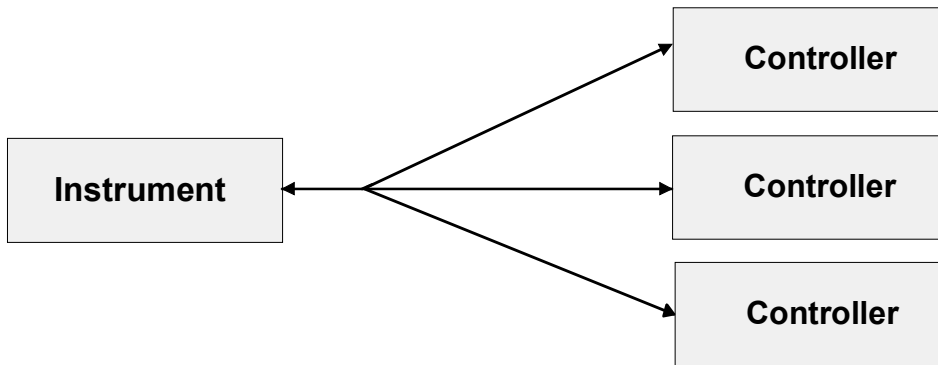
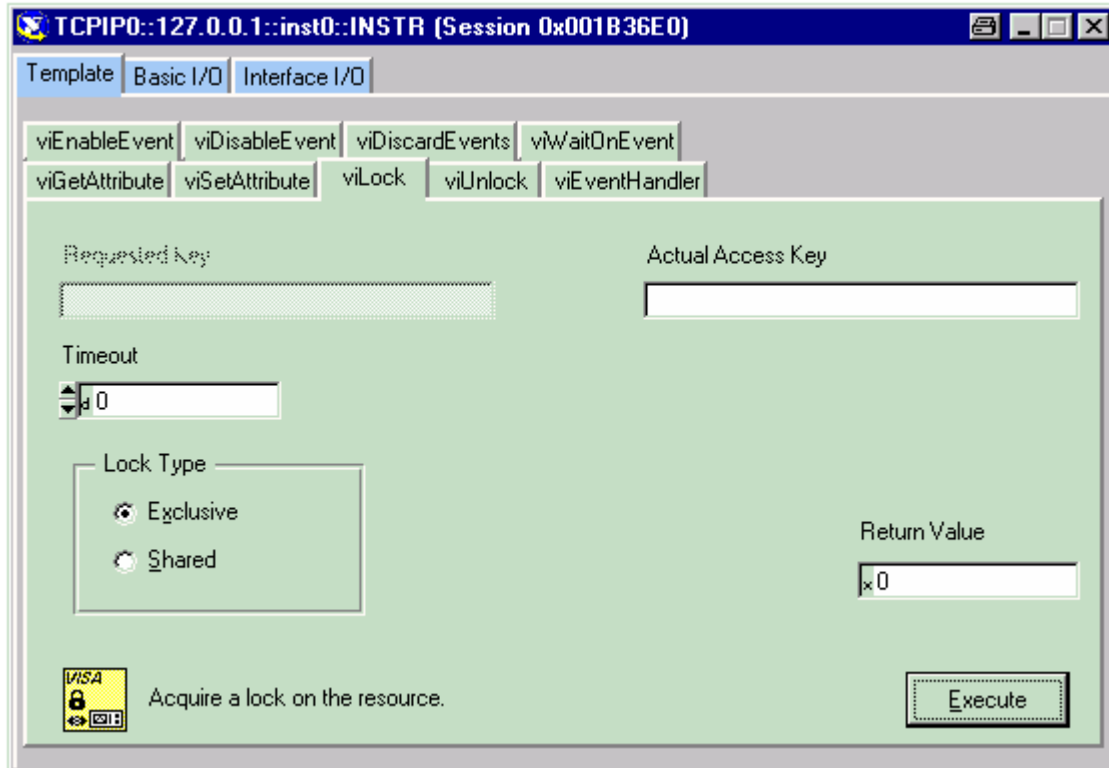

Fig. 8-4 Remote control via LAN from several controllers

The controllers can lock and unlock the instrument for exclusive access. This regulates access to the instrument of several controllers.

In the **'Measurement & Automation Control'** program, this setting is made on the **Template** tab.



### VXI-11 Interface Messages

On the Ethernet link, the interface messages are called low-level control messages. These messages can be used to emulate interface messages of the IEC/IEEE bus.

Table 8-4 VXI-11 Interface Messages#

Command	Effect on the instrument
&ABO (Abort)	Aborts the processing of the commands just received.
&DCL (Device Clear)	Aborts the processing of the commands just received and sets the command processing software to a defined initial state. Does not change the instrument setting.
&GTL (Go to Local)	Transition to the "Local" state (manual operation)
&GTR (Go to Remote)	Transition to the "Remote" state (remote control)
&GET (Group Execute Trigger)	Triggers a previously active device function (e.g. a sweep). The effect of the command is the same as with that of a pulse at the external trigger signal input.
&LLO (Local Lockout)	Disables switchover from remote control to manual operation by means of the front panel keys
&POL (Serial Poll)	Starts a serial poll
&NREN (Not Remote Enable)	Enables switchover from remote control to manual operation by means of the front panel keys

## USB Connection (USB and USB IN)

The instrument is equipped as standard with several USB (universal serial bus) interfaces.

### USB

Most of them are type A interfaces (host USB) which establish a connection to the controller. They can be used for connecting peripherals such as mouse and keyboard or a memory stick for data transmission. Two of the master USBs are at the instrument front, the others are at the rear.

### USB IN

One USB interface is a type B interface (device USB) and located at the rear of the instrument. It can be used for remote control (see chapter "[Remote Control - Basics](#)"). The instrument is assigned as device, not as host.

## Monitor Connector (MONITOR)

The 15-pin Sub-D female connector MONITOR at the rear panel is intended for connecting an external VGA monitor.

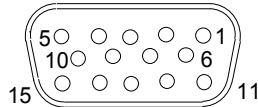

Pin	Signal	Pin	Signal	Pin	Signal
1	Red (output)	6	GND	11	(NC)
2	Green (output)	7	GND	12	(NC)
3	Blue (output)	8	GND	13	HSYNC (output)
4	(NC)	9	GND	14	VSYNC (output)
5	GND	10	GND	15	(NC)

Figure 8-5 Pin assignment of the MONITOR connector

## BERT Connector

The 9-pin Sub-D connector BERT at the rear panel is available for the input signals of the integrated bit error rate tester (option BER/BLE Measurement (K80)).

Pin	Signal	Pin	Signal
1	GND	6	CLOCK
2	GND	7	DATA
3	GND	8	DATA ENABLE
4	GND	9	RESTART
5	GND		

Figure 8-6 Pin assignment of the BERT connector

The input signals are not terminated in the instrument. The impedance (50 ohm) and the threshold (0.0128..1.998 V) of the inputs can be set in the BERT menu.

The following figure shows the circuit diagram of the BERT function.

Figure 8-7 BERT circuit diagram

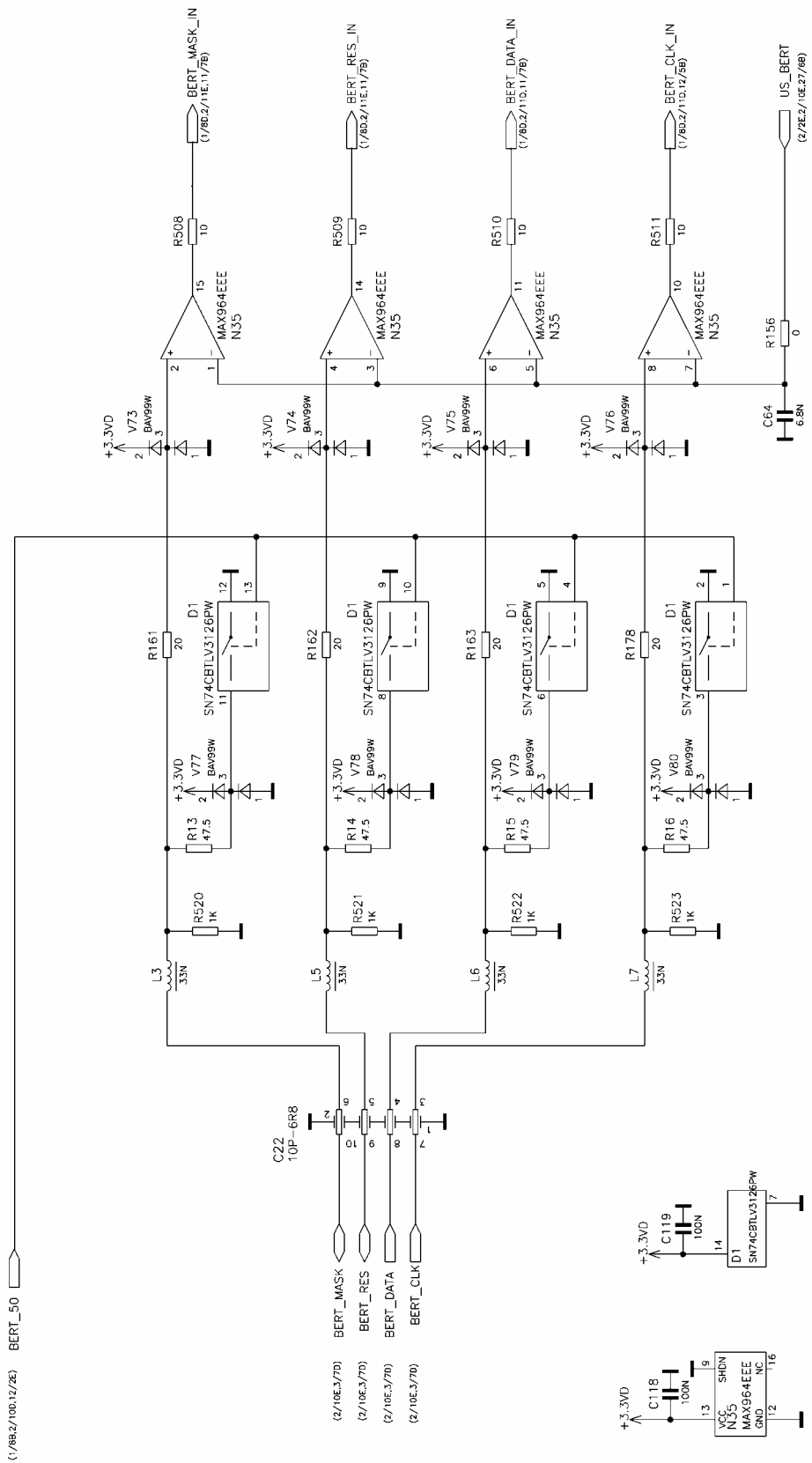



## Contents - Chapter 9 - "Error Messages"

<b>Error Messages .....</b>	<b>9.1</b>
Introduction - Status Information and Messages.....	9.1
Status Information .....	9.1
Error Messages .....	9.4
Alphabetical List of SCPI-Error Messages .....	9.5
Block data not allowed (-168).....	9.5
Character data not allowed (-148).....	9.5
Character data too long (-144) .....	9.5
Command error (-100).....	9.5
Data out of range (-222) .....	9.5
Device-specific error (-300).....	9.6
Exponent too large (-123).....	9.6
Expression data not allowed (-178).....	9.6
GET not allowed (-105) .....	9.6
Hardware error (-240).....	9.6
Hardware missing (-241) .....	9.6
Header suffix out of range (-114) .....	9.6
Illegal parameter value (-224) .....	9.7
Invalid block data (-161).....	9.7
Invalid character (-101) .....	9.7
Invalid character data (-141) .....	9.7
Invalid separator (-103) .....	9.7
Invalid suffix (-131).....	9.7
Missing parameter (-109) .....	9.8
No error (0).....	9.8
Numeric data not allowed (-128) .....	9.8
Out of memory (-225).....	9.8
Parameter not allowed (-108).....	9.8
Program mnemonic too long (-112) .....	9.8
Query interrupted (-410).....	9.8
Query unterminated (-420).....	9.9
Query deadlocked (-430).....	9.9
Queue overflow (-350).....	9.9
Self test failed ... (-330) .....	9.9
Settings conflict ... (-221).....	9.9

String data not allowed (-158) .....	9.10
Suffix not allowed (-138).....	9.10
Suffix too long (-134) .....	9.10
Syntax error (-102) .....	9.10
System error (-310) .....	9.10
Too many digits (-124) .....	9.11
Too much data (-223).....	9.11
Undefined header (-113) .....	9.11
Alphabetical List of Device-Specific Error Messages .....	9.12
Extern reference out of range or disconnected (50).....	9.12
Adjustment data invalid (183).....	9.12
Adjustment data missing (182).....	9.12
Adjustment failed (180) .....	9.12
Cannot access the EEPROM (202).....	9.13
Cannot access hardware (200) .....	9.13
Cannot open file (460).....	9.13
Cannot read file (462).....	9.13
Cannot write file (461) .....	9.13
Driver initialization failed (204) .....	9.13
File contains invalid data (465).....	9.14
Filename missing (463) .....	9.14
Hardware revision out of date (201) .....	9.14
Invalid EEPROM data (203).....	9.14
Invalid filename extension (464).....	9.14
No current list (241).....	9.14
This modulation forces other modulations off (140).....	9.15
Unknown list type specified (242).....	9.15
Waveform Protected (261) .....	9.15



## 9 Error Messages

### Introduction - Status Information and Messages

This chapter describes the error messages of the R&S Signal Generator. The error messages are output in the **Info** line on the screen and entered in the error error/event queue of the status reporting system.

A great variety of different messages such as status messages, error messages, warnings or information are displayed in the header field of the screen. Some error messages require that the error must be eliminated before correct instrument operation can be ensured. The info window with a list of current messages and a detailed description of each message can be opened with the **INFO** key

In the remote control mode, error messages are entered in the error/event queue of the status reporting system and can be queried with the command `SYSTEM:ERROR?`. If the error queue is empty, 0 ("No error") is returned.

### Status Information

The status messages are displayed in the header section of the screen. The status information gives the user an overview of the main operating states and settings of the instrument. The states are indicated for information only and do not necessitate any action by the user. Status information is displayed between the frequency and level fields, at the left of the info line or in the info line itself. On two-path instruments, all states that can occur independently in the two paths are displayed separately for each path. The associated path is indicated in the info line.

#### Status information displayed between the frequency and level fields:

**RF OFF**            The RF output is switched off

**MOD OFF**        All modulations are switched off.

**FREQ OFFSET**    A frequency offset is set.

The frequency entered and displayed in the frequency field takes any set frequency offset into consideration, e.g. an offset set for a downstream instrument. This means that with a frequency offset the frequency displayed in the header does not correspond to the frequency at the RF output, but rather to the frequency at the output of the downstream instrument.

This allows the desired frequency at the output of a downstream instrument to be entered in the frequency field. The signal generator changes the RF output frequency according to the entered offset.

However, the frequency entered and displayed in the Frequency/Phase menu of the RF/Ana Mod function block always corresponds to the RF output frequency. Any frequency offset is not taken into consideration.

The correlation is as follows:

**Freq in header = RF output frequency  
(= Freq in menu) + Freq offset (= Offset in menu)**

- OVERLOAD** The power of the external signal applied to the RF output is too high. The overload protection is tripped and the connection between the RF output and attenuator is interrupted. The overload protection is reset by pressing the **RF ON/OFF** key. The RF input is activated when the overload protection is reset.
- This messages is only indicated when the instrument is equipped with option R&S B3x, Overvoltage Protection (available for instruments with frequency options R&S B102/103/202/203). Two-path instruments require a separate option for each RF output (R&S B30/B32 (Path A) and R&S B35/B37 (Path B)).
- LEVEL OFFSET** A level offset is set.
- The level entered and displayed in the Level field takes the offset of any downstream attenuators/amplifiers into consideration by way of calculation. This means that with a level offset the level displayed in the header does not correspond to the level at the RF output, but rather to the level at the output of the downstream instrument.
- This allows the desired level at the output of downstream instruments to be entered. The signal generator changes the RF output level according to the set offset.
- However, the level entered and displayed in the **Level** menu of the **RF/Ana Mod** function block always corresponds to the RF output level. Any level offset is not taken into consideration.
- The correlation is as follows:
- $$\text{Level in header} = \text{RF output level} (= \text{Level in menu}) + \text{Level offset}$$
- EXT REF** An external reference is used.
- The external signal with selectable frequency and defined level must be input at the REF IN connector. It is output at the REF OUT connector.
- The reference frequency setting is effective for both paths.
- I/Q Out OFF** R&S AMU only:  
The I/Q output is switched off.
- BUSY** A setting or calculation is executed.

**Status information displayed to the left of the Info line:**

- REMOTE** The instrument is remote controlled. The keys on the front panel are usable, but all parameters are in **read only** mode.
- The **LOCAL** key switches the instrument from remote control to manual operation. The current command must be fully processed before the mode is switched, otherwise the instrument switches immediately back to remote control.
- REM-LLO** The instrument is remote (**RE**Mote) controlled. The **LOCAL** key is disabled by remote control with the command LLO (**LocalLockOut**). The keys on the front panel are usable, but all parameters are in **read only** mode.
- The instrument can be switched from remote control to manual operation by means of remote control only (e.g. with the Visual Basic command `CALL IBLOC (generator%)`).

<b>LOC-LLO</b>	<p>For operating directly the instrument is placed from remote control to manual operation (Local State). The <code>LOCAL</code> key was disabled by remote control with the command <code>LocalLockOut</code>.</p> <p>With the next activating of the remote control mode, the instrument cannot be switched to manual operation by the operator. The status information changes to REM LLO.</p> <p>The instrument can be switched to manual operation by means of remote control only (e.g. with the Visual Basic command <code>CALL IBLOC (generator%)</code>).</p>
<b>SYS CTRL</b>	<b>SYS CTRL</b> indicates that the instrument is controlling another instrument.

#### Status information displayed in the Info line:

<b>RFSweep LevelSweep LFSweep</b>	The indicated sweep is enabled.
<b>ALC On/Auto/S&amp;H</b>	<p>The status of the automatic level control is indicated:</p> <ul style="list-style-type: none"> <li>- ON = automatic level control permanently on</li> <li>- Auto = automatic level control is automatically adapted to the operating states</li> <li>- S&amp;H = automatic level control off, recalibration of the level whenever the level or frequency is set (sample and hold mode).</li> </ul>
<b>ListMode</b>	<p>List mode is active.</p> <p>The values of the frequency/level pairs in the selected list are set for the chosen dwell time.</p>
<b>AttFixed</b>	<p>Attenuator fixed mode is active.</p> <p>The uninterrupted level settings are made in a fixed range without attenuator switching. The variation range is set automatically when this mode is activated. The range is displayed under <b>Attenuator Fixed Range</b> in the <b>Level</b> menu.</p>
<b>UCorr</b>	<p>User Correction is active.</p> <p>The level is corrected by the given values in the selected user correction list. Correction is performed by the user-defined list values being added to the output level for the respective RF frequency. With frequencies which are not contained in the list, the level correction is determined by interpolation of the closest correction values.</p>
<b>OvenCold</b>	<p>The reference oscillator has not yet reached its nominal frequency.</p> <p>When switching on from the STANDBY mode, the specified frequency accuracy is reached immediately. If the power switch was switched off, the reference oscillator needs some warm-up time to reach its nominal frequency. During this period of time, the output frequency does not yet reach its final value either.</p>

## Error Messages

Messages indicate errors in the instrument. They are displayed in the info line in different colors depending on their importance and display duration. Errors (e.g. no calibration data) are displayed in red, information (e.g. file not found) and warnings in black. Warnings indicate less significant errors (e.g. the instrument operates outside specified data).

### **Volatile messages**

Volatile messages report automatic settings in the instrument (e.g. switching off of incompatible types of modulation) or on illegal entries that are not accepted by the instrument (e.g. range violations). They are displayed in the info line on a yellow background. They are displayed on top of status information or permanent messages.

Volatile messages do not normally demand user actions and disappear automatically after a brief period of time. They are stored in the history, however.

Remote-control command:

```
SYST:ERR? or SYST:ERR:ALL?
```

### **Permanent messages**

Permanent messages are displayed if an error occurs that impairs further instrument operation, e.g. a hardware fault. The error signaled by a permanent message must be eliminated before correct instrument operation can be ensured.

The message is displayed until the error is eliminated. It covers the status display in the info line. After error elimination, the message automatically disappears and is also recorded in the history.

Remote-control command:

```
SYST:SErr?
```

## Alphabetical List of SCPI-Error Messages

The following list contains all error messages defined in SCPI in alphabetical order. SCPI error messages are the same in all SCPI instruments. The errors are assigned negative numbers.

The error text being entered into the error/event queue or being displayed is printed in bold face on the left together with the error code. Below the error text, there is an explanation as to the respective error.

---

**Note:**

*The index provides a list of the error messages sorted according to their error codes.*

---

### Block data not allowed (-168)

The command contains legal block data which are not allowed at this point.

**Example:** The command `SOURce:BB:FOFFset` requires a numeric parameter – `BB:FOFF #13a`

**SCPI:** Command error - sets bit 5 in the ESR register

### Character data not allowed (-148)

The character data is prohibited for this command or at this point of the command.

**Example:** Command `SOUR:BB:FOFF` requires a numeric parameter.

**SCPI:** Command error - sets bit 5 in the ESR register

### Character data too long (-144)

The character data element contains more than 12 characters.

**SCPI:** Command error - sets bit 5 in the ESR register

### Command error (-100)

Generic error message that cannot detect a more specific error.

**SCPI:** Command error - sets bit 5 in the ESR register

### Data out of range (-222)

A value of the transmitted command was outside the legal range.

**Example:** Command `SOUR:BB:FOFF 50MHz` only permits entries in the range of min to max frequency.

**SCPI:** Execution error - sets bit 4 in the ESR register

## Device-specific error (-300)

Device-specific error not defined in greater detail.

**SCPI:** Device-specific error - sets bit 3 in the ESR register

## Exponent too large (-123)

The magnitude of the exponent is too large.

**SCPI:** Command error - sets bit 5 in the ESR register

## Expression data not allowed (-178)

The command contains a mathematical expression at an impermissible position.

**SCPI:** Command error - sets bit 5 in the ESR register

## GET not allowed (-105)

A Group Execute Trigger (GET) is within a command line.

**Note:** A Group Execute Trigger (GET) is only allowed at the end of a command line or in a separate command line.

**SCPI:** Command error - sets bit 5 in the ESR register

## Hardware error (-240)

A legal program command or a query could not be executed because of a hardware problem in the device.

**SCPI:** Execution error - sets bit 4 in the ESR register

## Hardware missing (-241)

A legal program command or a query could not be executed because of a missing device hardware.

**Example:** An option is not fitted.

**SCPI:** Execution error - sets bit 4 in the ESR register

## Header suffix out of range (-114)

The command contains an illegal numeric suffix.

**Example:** :SOURCE22 is not defined for the instrument.

**SCPI:** Command error - sets bit 5 in the ESR register

## Illegal parameter value (-224)

The parameter value is invalid.

- Example:** An invalid text parameter is indicated -  
:SOUR:BB:GSM:TRIG:SOUR TASTe
- SCPI:** Execution error - sets bit 4 in the ESR register

## Invalid block data (-161)

The command contains illegal block data.

- Example:** An END message was received before the expected number of data had been received or no numeric data element is sent after the introductory #
- SCPI:** Command error - sets bit 5 in the ESR register

## Invalid character (-101)

The command contains an invalid sign.

- Example:** A header contains an ampersand, "SOURCE&".
- SCPI:** Command error - sets bit 5 in the ESR register

## Invalid character data (-141)

The command contains an invalid value indication.

- Example:** ON is indicated instead of a numeric value for frequency setting -  
SOUR:BBIN:FOFF ON
- SCPI:** Command error - sets bit 5 in the ESR register

## Invalid separator (-103)

The command contains an impermissible sign instead of a separator.

- Example:** A semicolon is missing after the first command in a command line with several commands -  
"SOURce:BBIN:FOFFset 2MHz CFACTOR -2.5dB".
- SCPI:** Command error - sets bit 5 in the ESR register

## Invalid suffix (-131)

The suffix is not appropriate for this command.

- Example:** nHz is not defined.
- SCPI:** Command error - sets bit 5 in the ESR register

## Missing parameter (-109)

The command does not contain the required parameters.

**Example:** Command :SOUR:BBIN:FOFFset requires the indication of a parameter - "SOURce:BBIN:FOFFset; CFACTOR -2.5dB"  
**SCPI:** Command error - sets bit 5 in the ESR register

## No error (0)

This message is output if the error queue does not contain entries.

## Numeric data not allowed (-128)

The command contains a numeric data element the device does not accept in this position.

**Example:** The command :SOUR:BB:DM:COD requires an alphanumeric parameter - SOUR:BB:DM:COD GSM.  
**SCPI:** Command error - sets bit 5 in the ESR register

## Out of memory (-225)

The storage space available in the instrument is exhausted.

**SCPI:** Execution error - sets bit 4 in the ESR register

## Parameter not allowed (-108)

The command contains too many parameters.

**Example:** Command SOURce:BBIN:FOFFset permits only one frequency indication - ":BBIN:OFFSet 30 kHz, 40 kHz".  
**SCPI:** Command error - sets bit 5 in the ESR register

## Program mnemonic too long (-112)

The header contains more than 12 characters.

**SCPI:** Command error - sets bit 5 in the ESR register

## Query interrupted (-410)

This query has been interrupted.

**Example** After a query, the instrument receives new data before the response has been sent completely.  
**SCPI:** Query error - error in data request - sets bit 2 in the ESR register.



## Query unterminated (-420)

This query is missing or incomplete.

**Example** The instrument is addressed as a talker and receives incomplete data.

**SCPI:** Query error - error in data request - sets bit 2 in the ESR register.

## Query deadlocked (-430)

This query cannot be processed.

**Example** The input and output buffers are full, the instrument cannot be operated.

**SCPI:** Query error - error in data request - sets bit 2 in the ESR register.

## Queue overflow (-350)

This error code is entered into the queue instead of the actual error code if the queue is full. It indicates that an error has occurred but not been recorded in the queue. The original error message is lost.

**Remedy:** Reading out the error messages e.g. with command `SYSTem:ERRor:ALL?` clears the error queue.

**SCPI:** Device specific error- sets bit 3 in the ESR register

## Self test failed ... (-330)

An error was detected in the selftest named after the semicolon. An error-free operation of the module concerned is no longer guaranteed.

**SCPI:** Device specific error- sets bit 3 in the ESR register

## Settings conflict ... (-221)

There is a setting conflict between the two parameters indicated after the semicolon.

**Example:** The set FSK deviation is too large for the selected symbol rate.

**Remedy** One of the given values has to be corrected to obtain a valid output signal.

**SCPI:** Execution error - sets bit 4 in the ESR register

<b>Example:</b>	<b>Center frequency vs. frequency tuning range with phase continuous frequency setting (SMx instruments only)</b>  When changing the output frequency in the phase continuous frequency setting mode, only the frequency of the DDS synthesizer is changed. Therefore the usable DDS frequency range limits the allowed output frequency tuning range. The maximum usable DDS frequency range depends on the set tuning mode (medium or wide).
<b>Remedy</b>	Change to tuning mode wide or  Disable the phase continuous frequency setting mode, change the frequency and enable this mode again, if necessary

### String data not allowed (-158)

The command contains a legal string data element which is not allowed at this point.

<b>Example:</b>	A text parameter is set in quotation marks. <code>SOURce:BBIN:MODE "ANAL".</code>
<b>SCPI:</b>	Command error - sets bit 5 in the ESR register

### Suffix not allowed (-138)

A suffix is not allowed for this command or at this point of the command.

<b>Example:</b>	Command *RCL does not permit indicating a suffix.
<b>SCPI:</b>	Command error - sets bit 5 in the ESR register

### Suffix too long (-134)

The suffix contains more than 12 characters.

<b>SCPI:</b>	Command error - sets bit 5 in the ESR register
--------------	------------------------------------------------

### Syntax error (-102)

The command is invalid.

<b>Example:</b>	The command contains block data the instrument does not accept.
<b>SCPI:</b>	Command error - sets bit 5 in the ESR register

### System error (-310)

This error message suggests an error within the instrument. Please inform the R&S Service.

<b>SCPI:</b>	Device specific error- sets bit 3 in the ESR register
--------------	-------------------------------------------------------

**Too many digits (-124)**

The decimal numeric data element contains too many digits.

**SCPI:** Command error - sets bit 5 in the ESR register

**Too much data (-223)**

More data were sent by the host than the instrument can handle.

**SCPI:** Execution error - sets bit 4 in the ESR register

**Undefined header (-113)**

The sent command header has not been defined.

**Example:** Header ":\*XYZ" or ":SOURCE&" is undefined for every instrument.

**SCPI:** Command error - sets bit 5 in the ESR register

## Alphabetical List of Device-Specific Error Messages

The following list contains all error messages specific of the instrument in alphabetical order. The positive error codes mark the errors specific of the instrument.

The error text being entered into the error/event queue or being displayed is printed in bold face on the left together with the error code. Below the error text, there is an explanation as to the respective error.

---

**Note:**

*The index provides a list of the error messages sorted according to their error codes.*

---

### Extern reference out of range or disconnected (50)

External reference is selected but no external signal is applied or the signal is out of range.

- Remedy:** Check the selected reference signal source (internal or external) in the Reference Oscillator menu (Setup). Change setting to 'internal' if no appropriate external source is available.
- SCPI:** Device-specific error - sets bit 3 in the ESR register

### Adjustment data invalid (183)

Adjustment data are invalid and must be restored.

- Remedy:** The adjustment data have to be generated again by an internal or external adjustment or to be loaded into the instrument.
- SCPI:** Device-specific error - sets bit 3 in the ESR register

### Adjustment data missing (182)

Adjustment data are missing.

- Remedy:** The adjustment data have to be generated first by an internal or external adjustment or to be loaded into the instrument.
- SCPI:** Device-specific error - sets bit 3 in the ESR register

### Adjustment failed (180)

Adjustment could not be executed

- Remedy:** The adjustment data have to be generated first by an internal or external adjustment or to be loaded into the device (see section Adjustment).
- SCPI:** Device-specific error - sets bit 3 in the ESR register

## Cannot access the EEPROM (202)

A error occurs when writing or reading a EEPROM.

**Example:** The EEPROM is defect.

**SCPI:** Device-specific error - sets bit 3 in the ESR register

## Cannot access hardware (200)

The data transmission to a module was unsuccessful.

**Example:** The module is not installed, not properly installed or missing.

**SCPI:** Device-specific error - sets bit 3 in the ESR register

## Cannot open file (460)

The selected file can not be opened.

**Remedy:** Check the path and file name.

**SCPI:** Device-specific error - sets bit 3 in the ESR register

## Cannot read file (462)

The file can not be read.

**Example:** The file contents are not compatible with the file type.

**SCPI:** Device-specific error - sets bit 3 in the ESR register

## Cannot write file (461)

The file can not be written.

**Example:** The file is read-only.

**SCPI:** Device-specific error - sets bit 3 in the ESR register

## Driver initialization failed (204)

Initialization of a driver fails when booting the instrument firmware

**Example:** The driver is not compatible with the hardware or software configuration of the instrument.

**SCPI:** Device-specific error - sets bit 3 in the ESR register

## File contains invalid data (465)

The selected file contains data that is not valid for the file type. The file extension determines the data that is valid for this file type. If the file extension is changed the lists are no longer recognized and the data are therefore invalid.

**Example:** The extension of a waveform file (= \*.wv) was changed to \*.txt.

**SCPI:** Device-specific error - sets bit 3 in the ESR register

## Filename missing (463)

The desired operation cannot be executed because the file name is not specified.

**Example:** A file name has to be entered when creating a new list.

**SCPI:** Device-specific error - sets bit 3 in the ESR register

## Hardware revision out of date (201)

A later version of certain parts of the instrument is necessary to execute the function selected.

**Example:** The driver does not support the installed version of a module.

**SCPI:** Device-specific error - sets bit 3 in the ESR register

## Invalid EEPROM data (203)

Reading a EEPROM is possible, however the data are inconsistent.

**SCPI:** Device-specific error - sets bit 3 in the ESR register

## Invalid filename extension (464)

The file extension is not valid for the desired operation.

**Example:** The file extension for waveform list files is \*.wv. It is not possible to enter another file extension when storing a list.

**SCPI:** Device-specific error - sets bit 3 in the ESR register

## No current list (241)

There is no list selected. To execute the desired operation a list has to be selected in the related menu. If no list is available, a new list must be created.

**SCPI:** Device-specific error - sets bit 3 in the ESR register

**This modulation forces other modulations off (140)**

A modulation has been switched on which cannot be used at the same time as an already active modulation. The previous modulation has been switched off.

**Example:** Enabling modulation GSM/EDGE switches any active digital modulation off.

**SCPI:** Device-specific error - sets bit 3 in the ESR register

**Unknown list type specified (242)**

The list type selected is not valid for the desired operation

**Example:** The file extension for waveform list files is \*.wv. It is not possible to enter another file extension when selecting a list.

**SCPI:** Device-specific error - sets bit 3 in the ESR register

**Waveform Protected (261)**

The selected waveform file cannot be transferred to a controller. The waveform is produced with simulation software WinIQSIM and is protected.

**SCPI:** Device-specific error - sets bit 3 in the ESR register





# Alphabetical List of Commands

[SOURce]:BB:PATH:COUNT .....	6.66
[SOURce<[1] 2>]:AWGN:DISP:ORESults .....	6.55
[SOURce<[1] 2>]:BB:ARB:CLOCK .....	6.71
[SOURce<[1] 2>]:BB:ARB:CLOCK:MODE .....	6.71
[SOURce<[1] 2>]:BB:ARB:CLOCK:MULTIplier .....	6.71
[SOURce<[1] 2>]:BB:ARB:CLOCK:SOURce .....	6.72
[SOURce<[1] 2>]:BB:ARB:MCARrier:CARRier<0...31>:DELay .....	6.72
[SOURce<[1] 2>]:BB:ARB:MCARrier:CARRier<0...31>:FILE .....	6.72
[SOURce<[1] 2>]:BB:ARB:MCARrier:CARRier<0...31>:PHASe .....	6.73
[SOURce<[1] 2>]:BB:ARB:MCARrier:CARRier<0...31>:POWER .....	6.73
[SOURce<[1] 2>]:BB:ARB:MCARrier:CARRier<0...31>:STATe .....	6.74
[SOURce<[1] 2>]:BB:ARB:MCARrier:CARRier:COUNT .....	6.72
[SOURce<[1] 2>]:BB:ARB:MCARrier:CARRier:SPACing .....	6.73
[SOURce<[1] 2>]:BB:ARB:MCARrier:CFACtor:MODE .....	6.74
[SOURce<[1] 2>]:BB:ARB:MCARrier:CLOad .....	6.74
[SOURce<[1] 2>]:BB:ARB:MCARrier:CLOCK .....	6.75
[SOURce<[1] 2>]:BB:ARB:MCARrier:CREate .....	6.75
[SOURce<[1] 2>]:BB:ARB:MCARrier:EDIT:CARRier:DELay[:START] .....	6.75
[SOURce<[1] 2>]:BB:ARB:MCARrier:EDIT:CARRier:DELay:STEP .....	6.76
[SOURce<[1] 2>]:BB:ARB:MCARrier:EDIT:CARRier:EXECute .....	6.76
[SOURce<[1] 2>]:BB:ARB:MCARrier:EDIT:CARRier:FILE .....	6.76
[SOURce<[1] 2>]:BB:ARB:MCARrier:EDIT:CARRier:PHASe[:START] .....	6.76
[SOURce<[1] 2>]:BB:ARB:MCARrier:EDIT:CARRier:PHASe:STEP .....	6.77
[SOURce<[1] 2>]:BB:ARB:MCARrier:EDIT:CARRier:POWER[:START] .....	6.77
[SOURce<[1] 2>]:BB:ARB:MCARrier:EDIT:CARRier:POWER:STEP .....	6.77
[SOURce<[1] 2>]:BB:ARB:MCARrier:EDIT:CARRier:START .....	6.78
[SOURce<[1] 2>]:BB:ARB:MCARrier:EDIT:CARRier:STATe .....	6.78
[SOURce<[1] 2>]:BB:ARB:MCARrier:EDIT:CARRier:STOP .....	6.78
[SOURce<[1] 2>]:BB:ARB:MCARrier:OFILe .....	6.78
[SOURce<[1] 2>]:BB:ARB:MCARrier:PRESet .....	6.79
[SOURce<[1] 2>]:BB:ARB:MCARrier:SAMPles .....	6.79
[SOURce<[1] 2>]:BB:ARB:MCARrier:SETTing:CATalog? .....	6.79
[SOURce<[1] 2>]:BB:ARB:MCARrier:SETTing:LOAD .....	6.79
[SOURce<[1] 2>]:BB:ARB:MCARrier:SETTing:STORE .....	6.80
[SOURce<[1] 2>]:BB:ARB:MCARrier:TIME .....	6.80
[SOURce<[1] 2>]:BB:ARB:MCARrier:TIME:MODE .....	6.80
[SOURce<[1] 2>]:BB:ARB:PRESet .....	6.81
[SOURce<[1] 2>]:BB:ARB:SEQuence .....	6.81
[SOURce<[1] 2>]:BB:ARB:STATe .....	6.82
[SOURce<[1] 2>]:BB:ARB:TRIGger[:EXTernal<[1] 2>]:DELay .....	6.83
[SOURce<[1] 2>]:BB:ARB:TRIGger[:EXTernal<[1] 2>]:INHibit .....	6.83
[SOURce<[1] 2>]:BB:ARB:TRIGger:ARM:EXECute .....	6.82
[SOURce<[1] 2>]:BB:ARB:TRIGger:EXECute .....	6.83
[SOURce<[1] 2>]:BB:ARB:TRIGger:OBASeband:DELay .....	6.84
[SOURce<[1] 2>]:BB:ARB:TRIGger:OBASeband:INHibit .....	6.84
[SOURce<[1] 2>]:BB:ARB:TRIGger:OUTPut<[1]...4>:DELay .....	6.84
[SOURce<[1] 2>]:BB:ARB:TRIGger:OUTPut<[1]...4>:DELay:MAXimum? .....	6.85
[SOURce<[1] 2>]:BB:ARB:TRIGger:OUTPut<[1]...4>:DELay:MINimum? .....	6.85
[SOURce<[1] 2>]:BB:ARB:TRIGger:OUTPut<[1]...4>:MODE .....	6.85
[SOURce<[1] 2>]:BB:ARB:TRIGger:OUTPut<[1]...4>:OFFTime .....	6.86
[SOURce<[1] 2>]:BB:ARB:TRIGger:OUTPut<[1]...4>:ONTime .....	6.86
[SOURce<[1] 2>]:BB:ARB:TRIGger:OUTPut<[1]...4>:PATTern .....	6.86

[SOURce<[1] 2>]:BB:ARB:TRIGger:OUTPut<[1]...4>:PULSe:DIVider .....	6.87
[SOURce<[1] 2>]:BB:ARB:TRIGger:OUTPut<[1]...4>:PULSe:FREQUency?.....	6.87
[SOURce<[1] 2>]:BB:ARB:TRIGger:OUTPut:DELay:FIXed.....	6.84
[SOURce<[1] 2>]:BB:ARB:TRIGger:RMODE? .....	6.87
[SOURce<[1] 2>]:BB:ARB:TRIGger:SLENGth.....	6.88
[SOURce<[1] 2>]:BB:ARB:TRIGger:SLUNit.....	6.88
[SOURce<[1] 2>]:BB:ARB:TRIGger:SMODE .....	6.89
[SOURce<[1] 2>]:BB:ARB:TRIGger:SOURce .....	6.89
[SOURce<[1] 2>]:BB:ARB:TSIGNal:SINE:CREate .....	6.90
[SOURce<[1] 2>]:BB:ARB:TSIGNal:SINE:CREate:NAMed .....	6.89
[SOURce<[1] 2>]:BB:ARB:TSIGNal:SINE:FREQUency .....	6.90
[SOURce<[1] 2>]:BB:ARB:TSIGNal:SINE:PHASe .....	6.90
[SOURce<[1] 2>]:BB:ARB:TSIGNal:SINE:SAMPles .....	6.90
[SOURce<[1] 2>]:BB:ARB:WAVEform:CATalog? .....	6.91
[SOURce<[1] 2>]:BB:ARB:WAVEform:CATalog:LENGth?.....	6.91
[SOURce<[1] 2>]:BB:ARB:WAVEform:DATA .....	6.91,6.92
[SOURce<[1] 2>]:BB:ARB:WAVEform:DELeTe .....	6.92
[SOURce<[1] 2>]:BB:ARB:WAVEform:FREE .....	6.93
[SOURce<[1] 2>]:BB:ARB:WAVEform:POINTs .....	6.93
[SOURce<[1] 2>]:BB:ARB:WAVEform:SELeCt .....	6.93
[SOURce<[1] 2>]:BB:ARB:WAVEform:TAG? .....	6.94
[SOURce<[1] 2>]:BB:ARB:WSEGment .....	6.94
[SOURce<[1] 2>]:BB:ARB:WSEGment:CLOad .....	6.94
[SOURce<[1] 2>]:BB:ARB:WSEGment:CONFigure:CATalog? .....	6.95
[SOURce<[1] 2>]:BB:ARB:WSEGment:CONFigure:CLOCK.....	6.95
[SOURce<[1] 2>]:BB:ARB:WSEGment:CONFigure:CLOCK:MODE .....	6.95
[SOURce<[1] 2>]:BB:ARB:WSEGment:CONFigure:COMMeNt .....	6.96
[SOURce<[1] 2>]:BB:ARB:WSEGment:CONFigure:DELeTe.....	6.96
[SOURce<[1] 2>]:BB:ARB:WSEGment:CONFigure:LEVel[:MODE] .....	6.96
[SOURce<[1] 2>]:BB:ARB:WSEGment:CONFigure:OFIle.....	6.97
[SOURce<[1] 2>]:BB:ARB:WSEGment:CONFigure:SEGMeNt:APPend.....	6.97
[SOURce<[1] 2>]:BB:ARB:WSEGment:CONFigure:SEGMeNt:CATalog?.....	6.97
[SOURce<[1] 2>]:BB:ARB:WSEGment:CONFigure:SELeCt .....	6.98
[SOURce<[1] 2>]:BB:ARB:WSEGment:CREate .....	6.98
[SOURce<[1] 2>]:BB:ARB:WSEGment:NEXt .....	6.99
[SOURce<[1] 2>]:BB:DM:ASK:DEPTH .....	6.112
[SOURce<[1] 2>]:BB:DM:CLISt:CATalog?.....	6.132
[SOURce<[1] 2>]:BB:DM:CLISt:COpy .....	6.132
[SOURce<[1] 2>]:BB:DM:CLISt:DATA .....	6.133
[SOURce<[1] 2>]:BB:DM:CLISt:DELeTe .....	6.133
[SOURce<[1] 2>]:BB:DM:CLISt:POINTs? .....	6.134
[SOURce<[1] 2>]:BB:DM:CLISt:SELeCt .....	6.134
[SOURce<[1] 2>]:BB:DM:CLISt:TAG? .....	6.134
[SOURce<[1] 2>]:BB:DM:CLOCK:MODE .....	6.113
[SOURce<[1] 2>]:BB:DM:CLOCK:MuLTiplier .....	6.113
[SOURce<[1] 2>]:BB:DM:CLOCK:SOURce.....	6.113
[SOURce<[1] 2>]:BB:DM:COding .....	6.114
[SOURce<[1] 2>]:BB:DM:DLISt:CATalog?.....	6.135
[SOURce<[1] 2>]:BB:DM:DLISt:COpy .....	6.135
[SOURce<[1] 2>]:BB:DM:DLISt:DATA .....	6.136
[SOURce<[1] 2>]:BB:DM:DLISt:DATA? .....	6.136
[SOURce<[1] 2>]:BB:DM:DLISt:DATA:APPend.....	6.136
[SOURce<[1] 2>]:BB:DM:DLISt:DELeTe .....	6.137
[SOURce<[1] 2>]:BB:DM:DLISt:POINTs .....	6.137
[SOURce<[1] 2>]:BB:DM:DLISt:SELeCt .....	6.137
[SOURce<[1] 2>]:BB:DM:DLISt:TAG? .....	6.138
[SOURce<[1] 2>]:BB:DM:FILeTer:PARAmeter .....	6.114
[SOURce<[1] 2>]:BB:DM:FILeTer:PARAmeter:APCO25 .....	6.114

[SOURce<[1] 2>]:BB:DM:FILTer:PARAmeter:COsine .....	6.115
[SOURce<[1] 2>]:BB:DM:FILTer:PARAmeter:GAUSSs .....	6.115
[SOURce<[1] 2>]:BB:DM:FILTer:PARAmeter:LPASSs .....	6.115
[SOURce<[1] 2>]:BB:DM:FILTer:PARAmeter:PGAuss .....	6.115
[SOURce<[1] 2>]:BB:DM:FILTer:PARAmeter:RCOSine .....	6.115
[SOURce<[1] 2>]:BB:DM:FILTer:PARAmeter:SPHase .....	6.116
[SOURce<[1] 2>]:BB:DM:FILTer:TYPE .....	6.116
[SOURce<[1] 2>]:BB:DM:FLISt:CATalog .....	6.138
[SOURce<[1] 2>]:BB:DM:FLISt:DELeTe .....	6.138
[SOURce<[1] 2>]:BB:DM:FLISt:FREE .....	6.139
[SOURce<[1] 2>]:BB:DM:FLISt:POINts .....	6.139
[SOURce<[1] 2>]:BB:DM:FLISt:SELeCt .....	6.139
[SOURce<[1] 2>]:BB:DM:FORMat .....	6.116
[SOURce<[1] 2>]:BB:DM:FRAMp:FDElay .....	6.118
[SOURce<[1] 2>]:BB:DM:MDElay? .....	6.117
[SOURce<[1] 2>]:BB:DM:MLISt:CATalog .....	6.140
[SOURce<[1] 2>]:BB:DM:MLISt:DELeTe .....	6.140
[SOURce<[1] 2>]:BB:DM:MLISt:FREE .....	6.140
[SOURce<[1] 2>]:BB:DM:MLISt:POINts .....	6.141
[SOURce<[1] 2>]:BB:DM:MLISt:SELeCt .....	6.141
[SOURce<[1] 2>]:BB:DM:OBASeband:TRIGger:INHibit .....	6.125
[SOURce<[1] 2>]:BB:DM:PATTern .....	6.117
[SOURce<[1] 2>]:BB:DM:PRAMp[:STATe] .....	6.119
[SOURce<[1] 2>]:BB:DM:PRAMp:ATTenuation .....	6.118
[SOURce<[1] 2>]:BB:DM:PRAMp:BBONly[:STATe] .....	6.118
[SOURce<[1] 2>]:BB:DM:PRAMp:RDElay .....	6.118
[SOURce<[1] 2>]:BB:DM:PRAMp:SHAPE .....	6.119
[SOURce<[1] 2>]:BB:DM:PRAMp:SOURce .....	6.119
[SOURce<[1] 2>]:BB:DM:PRAMp:TIME .....	6.119
[SOURce<[1] 2>]:BB:DM:PRBS[:LENGth] .....	6.120
[SOURce<[1] 2>]:BB:DM:PRESet .....	6.120
[SOURce<[1] 2>]:BB:DM:SEQUence .....	6.121
[SOURce<[1] 2>]:BB:DM:SETTing:CATalog? .....	6.141
[SOURce<[1] 2>]:BB:DM:SETTing:DELeTe .....	6.142
[SOURce<[1] 2>]:BB:DM:SETTing:LOAD .....	6.142
[SOURce<[1] 2>]:BB:DM:SETTing:STORe .....	6.142
[SOURce<[1] 2>]:BB:DM:SOURce .....	6.121
[SOURce<[1] 2>]:BB:DM:SRATE .....	6.122
[SOURce<[1] 2>]:BB:DM:STANdard .....	6.122
[SOURce<[1] 2>]:BB:DM:STANdard:ULISt:CATalog? .....	6.142
[SOURce<[1] 2>]:BB:DM:STANdard:ULISt:DELeTe .....	6.143
[SOURce<[1] 2>]:BB:DM:STANdard:ULISt:LOAD .....	6.143
[SOURce<[1] 2>]:BB:DM:STANdard:ULISt:STORe .....	6.143
[SOURce<[1] 2>]:BB:DM:STATE .....	6.123
[SOURce<[1] 2>]:BB:DM:SWITChing:SOURce .....	6.123
[SOURce<[1] 2>]:BB:DM:SWITChing:STATE .....	6.123
[SOURce<[1] 2>]:BB:DM:TRIGger[:EXTernal<[1] 2>]:DElay .....	6.124
[SOURce<[1] 2>]:BB:DM:TRIGger[:EXTernal<[1] 2>]:INHibit .....	6.125
[SOURce<[1] 2>]:BB:DM:TRIGger:ARM:EXECute .....	6.123
[SOURce<[1] 2>]:BB:DM:TRIGger:EXECute .....	6.124
[SOURce<[1] 2>]:BB:DM:TRIGger:OBASeband:DElay .....	6.125
[SOURce<[1] 2>]:BB:DM:TRIGger:OUTPut<[1]..4>:DElay .....	6.126
[SOURce<[1] 2>]:BB:DM:TRIGger:OUTPut<[1]..4>:DElay:MAXimum? .....	6.126
[SOURce<[1] 2>]:BB:DM:TRIGger:OUTPut<[1]..4>:DElay:MINimum? .....	6.127
[SOURce<[1] 2>]:BB:DM:TRIGger:OUTPut<[1]..4>:MODE .....	6.127
[SOURce<[1] 2>]:BB:DM:TRIGger:OUTPut<[1]..4>:OFFTime .....	6.127
[SOURce<[1] 2>]:BB:DM:TRIGger:OUTPut<[1]..4>:ONTIME .....	6.128
[SOURce<[1] 2>]:BB:DM:TRIGger:OUTPut<[1]..4>:PULSe:DIVider .....	6.128

[SOURce<[1] 2>]:BB:DM:TRIGger:OUTPut<[1]..4>:PULSe:FREQuency?	6.129
[SOURce<[1] 2>]:BB:DM:TRIGger:OUTPut<[1]..4>:PATTern	6.128
[SOURce<[1] 2>]:BB:DM:TRIGger:OUTPut:DELay:FIXed	6.126
[SOURce<[1] 2>]:BB:DM:TRIGger:RMODE?	6.129
[SOURce<[1] 2>]:BB:DM:TRIGger:SLENgth	6.130
[SOURce<[1] 2>]:BB:DM:TRIGger:SOURce	6.130
[SOURce<[1] 2>]:BB:FOFFset	6.65
[SOURce<[1] 2>]:BB:PGain	6.66
[SOURce<[1] 2>]:BB:POFFset	6.66
[SOURce<[1] 2>]:BB:ROUte	6.67
[SOURce<[1] 2>]:AM[:DEPTh]	6.50
[SOURce<[1] 2>]:AM:EXTernal:COUPLing	6.51
[SOURce<[1] 2>]:AM:SENSitivity	6.51
[SOURce<[1] 2>]:AM:SOURce	6.51
[SOURce<[1] 2>]:AM:STATe	6.52
[SOURce<[1] 2>]:AWGN:BRATe	6.53
[SOURce<[1] 2>]:AWGN:BWIDth	6.54
[SOURce<[1] 2>]:AWGN:BWIDth:NOISe	6.54
[SOURce<[1] 2>]:AWGN:BWIDth <sup>3</sup> RATio	6.54
[SOURce<[1] 2>]:AWGN:CNRatio	6.54
[SOURce<[1] 2>]:AWGN:DISPlay:MODE	6.55
[SOURce<[1] 2>]:AWGN:ENRatio	6.56
[SOURce<[1] 2>]:AWGN:FREQuency:RESulting	6.56
[SOURce<[1] 2>]:AWGN:FREQuency:TARGet	6.56
[SOURce<[1] 2>]:AWGN:MODE	6.57
[SOURce<[1] 2>]:AWGN:POWer:CARRier	6.57
[SOURce<[1] 2>]:AWGN:POWer:MODE	6.57
[SOURce<[1] 2>]:AWGN:POWer:NOISe	6.58
[SOURce<[1] 2>]:AWGN:POWer:NOISe:TOTal?	6.58
[SOURce<[1] 2>]:AWGN:POWer:RMODE	6.59
[SOURce<[1] 2>]:AWGN:POWer:SUM?	6.59
[SOURce<[1] 2>]:AWGN:POWer:SUM:PEP?	6.59
[SOURce<[1] 2>]:AWGN:STATe	6.60
[SOURce<[1] 2>]:BB:CFACtor?	6.64
[SOURce<[1] 2>]:BB:IMPairment:IQRatio	6.144
[SOURce<[1] 2>]:BB:IMPairment:LEAKage:I	6.145
[SOURce<[1] 2>]:BB:IMPairment:LEAKage:Q	6.145
[SOURce<[1] 2>]:BB:IMPairment:OPTimization:MODE	6.145
[SOURce<[1] 2>]:BB:IMPairment:OPTimization:STATe	6.145
[SOURce<[1] 2>]:BB:IMPairment:STATe	6.146
[SOURce<[1] 2>]:BB:IQGain	6.146
[SOURce<[1] 2>]:BB:MEASurement:CFACtor?	6.61
[SOURce<[1] 2>]:BB:MEASurement:DURation	6.61
[SOURce<[1] 2>]:BB:MEASurement:POWer:PEAK?	6.62
[SOURce<[1] 2>]:BB:MEASurement:POWer:RMS?	6.62
[SOURce<[1] 2>]:BB:MEASurement:RTIME	6.62
[SOURce<[1] 2>]:BB:MEASurement:SOURce	6.62
[SOURce<[1] 2>]:BB:MEASurement:STATe	6.63
[SOURce<[1] 2>]:BB:POWer:PEAK?	6.64
[SOURce<[1] 2>]:BB:POWer:RMS?	6.64
[SOURce<[1] 2>]:CORRection:CSET[:SElect]	6.154
[SOURce<[1] 2>]:CORRection:CSET:DATA[:SENSor<[1] 2 3>[:POWer]:SONCe	6.150
[SOURce<[1] 2>]:CORRection:DEXChange:AFILe:CATalog?	6.151
[SOURce<[1] 2>]:CORRection:DEXChange:AFILe:EXTension	6.151
[SOURce<[1] 2>]:CORRection:DEXChange:AFILe:SElect	6.152
[SOURce<[1] 2>]:CORRection:DEXChange:AFILe:SEParator:COLumn	6.152
[SOURce<[1] 2>]:CORRection:DEXChange:AFILe:SEParator:DECimal	6.153
[SOURce<[1] 2>]:CORRection:DEXChange:EXECute	6.153

[SOURce<[1] 2>:]CORRection:DEXChange:MODE .....	6.154
[SOURce<[1] 2>:]CORRection:DEXChange:SElect .....	6.154
[SOURce<[1] 2>:]FM[:DEVIation] .....	6.156
[SOURce<[1] 2>:]FM:EXTErnal:COUPLing .....	6.156
[SOURce<[1] 2>:]FM:MODE .....	6.157
[SOURce<[1] 2>:]FM:SENSitivity .....	6.157
[SOURce<[1] 2>:]FM:SOURce .....	6.157
[SOURce<[1] 2>:]FM:STATe .....	6.157
[SOURce<[1] 2>:]FREQuency[:CW]:FIXed] .....	6.159
[SOURce<[1] 2>:]FREQuency:CENTer .....	6.158
[SOURce<[1] 2>:]FREQuency:MANual .....	6.160
[SOURce<[1] 2>:]FREQuency:MODE .....	6.160
[SOURce<[1] 2>:]FREQuency:OFFSet .....	6.161
[SOURce<[1] 2>:]FREQuency:PHASe:CONTInuous:STATe .....	6.161
[SOURce<[1] 2>:]FREQuency:SPAN .....	6.161
[SOURce<[1] 2>:]FREQuency:START .....	6.162
[SOURce<[1] 2>:]FREQuency:STEP[:NCRement] .....	6.162
[SOURce<[1] 2>:]FREQuency:STEP:MODE .....	6.163
[SOURce<[1] 2>:]FREQuency:STOP .....	6.162
[SOURce<[1] 2>:]IQ:CREStfactor .....	6.208
[SOURce<[1] 2>:]IQ:GAIN .....	6.208
[SOURce<[1] 2>:]IQ:IMPairment[:STATe] .....	6.210
[SOURce<[1] 2>:]IQ:IMPairment:LEAKage:I .....	6.209
[SOURce<[1] 2>:]IQ:IMPairment:LEAKage:Q .....	6.209
[SOURce<[1] 2>:]IQ:SOURce .....	6.210
[SOURce<[1] 2>:]IQ:STATe .....	6.210
[SOURce<[1] 2>:]IQ:SWap[:STATe] .....	6.210
[SOURce<[1] 2>:]IQ:WBState .....	6.210
[SOURce<[1] 2>:]LIS:DWELI .....	6.177
[SOURce<[1] 2>:]LIST:CATalog? .....	6.173
[SOURce<[1] 2>:]LIST:DELEte .....	6.173
[SOURce<[1] 2>:]LIST:DELEte:ALL .....	6.173
[SOURce<[1] 2>:]LIST:DEXChange:AFILe:CATalog? .....	6.174
[SOURce<[1] 2>:]LIST:DEXChange:AFILe:EXTension .....	6.174
[SOURce<[1] 2>:]LIST:DEXChange:AFILe:SElect .....	6.175
[SOURce<[1] 2>:]LIST:DEXChange:AFILe:SEParator:COLumn .....	6.175
[SOURce<[1] 2>:]LIST:DEXChange:AFILe:SEParator:DECimal .....	6.175
[SOURce<[1] 2>:]LIST:DEXChange:EXECute .....	6.176
[SOURce<[1] 2>:]LIST:DEXChange:MODE .....	6.176
[SOURce<[1] 2>:]LIST:DEXChange:SElect .....	6.177
[SOURce<[1] 2>:]LIST:FREQuency .....	6.177
[SOURce<[1] 2>:]LIST:FREQuency:POINts? .....	6.178
[SOURce<[1] 2>:]LIST:INDex:START .....	6.178
[SOURce<[1] 2>:]LIST:INDex:STOP .....	6.178
[SOURce<[1] 2>:]LIST:LEARn .....	6.179
[SOURce<[1] 2>:]LIST:MODE .....	6.179
[SOURce<[1] 2>:]LIST:POWER .....	6.179
[SOURce<[1] 2>:]LIST:POWER:POINts? .....	6.180
[SOURce<[1] 2>:]LIST:TRIGger:SOURce .....	6.181
[SOURce<[1] 2>:]PHASe .....	6.183
[SOURce<[1] 2>:]PHASe:REFerence .....	6.183
[SOURce<[1] 2>:]PM[:DEVIation] .....	6.184
[SOURce<[1] 2>:]PM:EXTErnal:COUPLing .....	6.184
[SOURce<[1] 2>:]PM:MODE .....	6.185
[SOURce<[1] 2>:]PM:SENSitivity .....	6.185
[SOURce<[1] 2>:]PM:SOURce .....	6.185
[SOURce<[1] 2>:]PM:STATe .....	6.186
[SOURce<[1] 2>:]POWER[:LEVel][:IMMEDIATE][:AMPLitude] .....	6.189

[SOURce<[1] 2>:]POWER[:LEVel][:IMMediate]:OFFSet .....	6.189
[SOURce<[1] 2>:]POWER:ALC[:STATe] .....	6.188
[SOURce<[1] 2>:]POWER:ALC:SONCe .....	6.188
[SOURce<[1] 2>:]POWER:LIMit[:AMPLitude] .....	6.190
[SOURce<[1] 2>:]POWER:MANual .....	6.190
[SOURce<[1] 2>:]POWER:MODE .....	6.191
[SOURce<[1] 2>:]POWER:PEP? .....	6.191
[SOURce<[1] 2>:]POWER:START .....	6.192
[SOURce<[1] 2>:]POWER:STEP[:INCRement] .....	6.192
[SOURce<[1] 2>:]POWER:STEP:MODE .....	6.192
[SOURce<[1] 2>:]POWER:STOP .....	6.193
[SOURce<[1] 2>:]PULM:POLarity .....	6.194
[SOURce<[1] 2>:]PULM:SOURce .....	6.195
[SOURce<[1] 2>:]PULM:STATe .....	6.195
[SOURce<[1] 2>:]SWEEp[:FREQuency]:DWELl .....	6.199
[SOURce<[1] 2>:]SWEEp[:FREQuency]:EXECute .....	6.199
[SOURce<[1] 2>:]SWEEp[:FREQuency]:MODE .....	6.200
[SOURce<[1] 2>:]SWEEp[:FREQuency]:POINts .....	6.200
[SOURce<[1] 2>:]SWEEp[:FREQuency]:SPACing .....	6.201
[SOURce<[1] 2>:]SWEEp[:FREQuency]:STEP[:LINear] .....	6.201
[SOURce<[1] 2>:]SWEEp[:FREQuency]:STEP:LOGarithmic .....	6.202
[SOURce<[1] 2>:]SWEEp:POWER:DWELl .....	6.202
[SOURce<[1] 2>:]SWEEp:POWER:EXECute .....	6.202
[SOURce<[1] 2>:]SWEEp:POWER:MODE .....	6.203
[SOURce<[1] 2>:]SWEEp:POWER:POINts .....	6.203
[SOURce<[1] 2>:]SWEEp:POWER:SPACing:MODE? .....	6.204
[SOURce<[1] 2>:]SWEEp:POWER:STEP[:LOGarithmic] .....	6.204
[SOURce<1 2>:]POWER:ALC:OMODE .....	6.188
[SOURce:]AM:BBANd[:STATe] .....	6.50
[SOURce:]AM:BBANd:SENSitivity? .....	6.50
[SOURce:]CORRection[:STATe] .....	6.155
[SOURce:]CORRection:CSET:CATalog? .....	6.148
[SOURce:]CORRection:CSET:DATA:FREQuency .....	6.148
[SOURce:]CORRection:CSET:DATA:FREQuency:POINts? .....	6.149
[SOURce:]CORRection:CSET:DATA:POWER .....	6.149
[SOURce:]CORRection:CSET:DATA:POWER:MLEVel<[1]...9> .....	6.150
[SOURce:]CORRection:CSET:DATA:POWER:MLEVel:STATe .....	6.150
[SOURce:]CORRection:CSET:DATA:POWER:POINts? .....	6.149
[SOURce:]CORRection:CSET:DELete .....	6.151
[SOURce:]CORRection:MLEVel <sup>°</sup> STATe .....	6.155
[SOURce:]CORRection:VALue? .....	6.155
[SOURce:]FREQuency[:CW :FIXed]:RCL .....	6.159
[SOURce:]INPut:BERT:IMPedance .....	6.15
[SOURce:]INPut:BERT:THReshold .....	6.15
[SOURce:]INPut:DATA:IMPedance .....	6.205
[SOURce:]INPut:DATA:THReshold .....	6.205
[SOURce:]INPut:MODext:IMPedance .....	6.206
[SOURce:]INPut:TRIGger:BBANd:SLOPe .....	6.206
[SOURce:]INPut:TRIGger:IMPedance .....	6.206
[SOURce:]INPut:TRIGger:LEVel .....	6.207
[SOURce:]INPut:TRIGger:SLOPe .....	6.207
[SOURce:]IQ:OUTPut:BIAS:COUPling[:STATe] .....	6.211
[SOURce:]IQ:OUTPut:BIAS:I .....	6.211
[SOURce:]IQ:OUTPut:BIAS:OPTimization[:RF]:STATe .....	6.212
[SOURce:]IQ:OUTPut:BIAS:Q .....	6.211
[SOURce:]IQ:OUTPut:DIGital:CDEVice? .....	6.214
[SOURce:]IQ:OUTPut:DIGital:OFLow:HOLD:RESet .....	6.214
[SOURce:]IQ:OUTPut:DIGital:OFLow:HOLD:STATe? .....	6.215

[SOURce:]IQ:OUTPut:DiGital:OFLOW:STATe?	6.215
[SOURce:]IQ:OUTPut:DiGital:PON	6.215
[SOURce:]IQ:OUTPut:DiGital:POWer:LEVel	6.216
[SOURce:]IQ:OUTPut:DiGital:POWer:PEP	6.216
[SOURce:]IQ:OUTPut:DiGital:POWer:STEP[:INCRement]	6.216
[SOURce:]IQ:OUTPut:DiGital:POWer:STEP:MODE	6.216
[SOURce:]IQ:OUTPut:DiGital:SRATe	6.217
[SOURce:]IQ:OUTPut:DiGital:SRATe:FIFO[:STATUs]?	6.217
[SOURce:]IQ:OUTPut:DiGital:SRATe:SOURce	6.218
[SOURce:]IQ:OUTPut:DiGital:STATe	6.218
[SOURce:]IQ:OUTPut:LEVel	6.212
[SOURce:]IQ:OUTPut:LEVel:PEP:RESult	6.212
[SOURce:]IQ:OUTPut:MODE	6.213
[SOURce:]IQ:OUTPut:OFFSet:I	6.213
[SOURce:]IQ:OUTPut:OFFSet:Q	6.213
[SOURce:]IQ:OUTPut:POWer:VIA	6.217
[SOURce:]IQ:OUTPut:TYPE	6.213
[SOURce:]LFOutput[:STATe]	6.166
[SOURce:]LFOutput:FREQuency	6.165
[SOURce:]LFOutput:FREQuency:MANual	6.165
[SOURce:]LFOutput:FREQuency:MODE	6.165
[SOURce:]LFOutput:FREQuency:START	6.166
[SOURce:]LFOutput:FREQuency:STOP	6.166
[SOURce:]LFOutput:SWEEp[:FREQuency]:DWELl	6.167
[SOURce:]LFOutput:SWEEp[:FREQuency]:EXECute	6.167
[SOURce:]LFOutput:SWEEp[:FREQuency]:MODE	6.167
[SOURce:]LFOutput:SWEEp[:FREQuency]:POINts	6.168
[SOURce:]LFOutput:SWEEp[:FREQuency]:SHAPE	6.168
[SOURce:]LFOutput:SWEEp[:FREQuency]:SPACing	6.169
[SOURce:]LFOutput:SWEEp[:FREQuency]:STEP[:LINear]	6.169
[SOURce:]LFOutput:SWEEp[:FREQuency]:STEP:LOGarithmic	6.169
[SOURce:]LFOutput:VOLTage	6.170
[SOURce:]MODulation:STATe	6.182
[SOURce:]POWer[:LEVel][:IMMEDIATE]:RCL	6.190
[SOURce:]ROSCillator[:INTernal]:ADJust[:STATe]	6.197
[SOURce:]ROSCillator[:INTernal]:ADJust:VALue	6.197
[SOURce:]ROSCillator:EXTernal:FREQuency	6.196
[SOURce:]ROSCillator:EXTernal:SBANdwidth	6.196
[SOURce:]ROSCillator:SOURce	6.197
[SOURce:]SWEEp[:FREQuency]:SHAPE	6.201
[SOURce:]SWEEp:POWer:SHAPE	6.203
BERT block	2.5
BERT:RESult?	6.9
BERT:SEQuence	6.10
BERT:SETup:CLOCK[:POLarity]	6.10
BERT:SETup:DATA[:POLarity]	6.11
BERT:SETup:DENable	6.11
BERT:SETup:IGNore	6.11
BERT:SETup:MCOunt	6.12
BERT:SETup:MERRor	6.12
BERT:SETup:REStart:STATe	6.13
BERT:SETup:TYPE	6.13
BERT:START	6.14
BERT:STATe	6.14
BERT:STOP	6.14
BERT:UNIT	6.15
BLER:RESult?	6.9
BLER:SEQuence	6.10

BLER:SETup:CLOCK[:POLarity]	6.10
BLER:SETup:CORDer	6.10
BLER:SETup:DATA[:POLarity]	6.11
BLER:SETup:DENable	6.11
BLER:SETup:MCOunt	6.12
BLER:SETup:MERRor	6.12
BLER:SETup:TYPE?	6.13
BLER:START	6.14
BLER:STATe	6.14
BLER:STOP	6.14
BLER:UNIT	6.15
CALibration<[1] 2>:FMOFset[:MEASure]?	6.18
CALibration<[1] 2>:FREQuency[:MEASure]?	6.18
CALibration<[1] 2>:IQModulation:LOCal?	6.18
CALibration<[1] 2>:IQModulator:FULL?	6.18
CALibration<[1] 2>:LEVel[:MEASure]?	6.19
CALibration<[1] 2>:LEVel:HACCuracy[:STATe]	6.19
CALibration<[1] 2>:LEVel:STATe	6.19
CALibration:ALL[:MEASure]?	6.17
CALibration:BBIN[:MEASure]?	6.17
CLOCK:INPut:FREQuency	6.20
CLOCK:INPut:SLOPe	6.20
CLOCK:OUTPut:MODE?	6.20
CLOCK:OUTPut:SOURce?	6.21
DEvice:PRESet	6.6
DIAGnostic[:MEASure]:POINt?	6.24
DIAGnostic<[1] 2>:BGINfo?	6.22
DIAGnostic<[1] 2>:BGINfo:CATalog?	6.23
DIAGnostic<[1] 2>:POINt:CATalog?	6.23
DIAGnostic:INFO:OTIMe?	6.23
DIAGnostic:INFO:POCounT?	6.23
DISPlay:PSAVE[:STATe]	6.25
DISPlay:PSAVE:HOLDoff	6.25
INITiate<[1]...3>[:POWER]:CONTinuous	6.42
KBOard:LANGUage	6.28
KBOard:LAYout	6.28
MMEMory:CATalog?	6.32
MMEMory:CATalog:LENGth?	6.33
MMEMory:CDIRectory	6.33
MMEMory:COpy	6.34
MMEMory:DATA	6.34
MMEMory:DCATalog?	6.35
MMEMory:DCATalog:LENGth?	6.35
MMEMory:DELeTe	6.35
MMEMory:LOAD:STATe	6.36
MMEMory:MDIRectory	6.36
MMEMory:MOVe	6.36
MMEMory:MSIS	6.37
MMEMory:RDIRectory	6.37
MMEMory:STORe:STATe	6.37
OUTPut<[1] 2>:PROTection:CLear	6.40
OUTPut<[1] 2>:PROTection:TRIPped?	6.40
OUTPut:[STATe]	6.41
OUTPut:[STATe:]PON	6.41
OUTPut:AFIXed:RANGe:LOWer?	6.38
OUTPut:AFIXed:RANGe:UPPer?	6.38
OUTPut:AMODE	6.39
OUTPut:BLANK:LIST:STATe	6.39



OUTPut:BLANK:POLarity .....	6.39
OUTPut:IMPedance .....	6.40
OUTPut:PROTEction:CLEar .....	6.40
OUTPut:USER<1...4>:SOURce .....	6.41
READ<[1]...3>[:POWer]? .....	6.43
SENSe<[1]...3>[:POWer]:CORRection:SPDeVice:STATe .....	6.43
SENSe<[1]...3>[:POWer]:DISPlay:PERManent:STATe .....	6.43
SENSe<[1]...3>[:POWer]:FILTer:LENGth[:USER] .....	6.44
SENSe<[1]...3>[:POWer]:FILTer:LENGth:AUTO? .....	6.44
SENSe<[1]...3>[:POWer]:FILTer:NSRatio .....	6.44, 6.45
SENSe<[1]...3>[:POWer]:FILTer:SONCe .....	6.45
SENSe<[1]...3>[:POWer]:FILTer:TYPE .....	6.45
SENSe<[1]...3>[:POWer]:FREQuency .....	6.46
SENSe<[1]...3>[:POWer]:OFFSet .....	6.46
SENSe<[1]...3>[:POWer]:OFFSet:STATe .....	6.46
SENSe<[1]...3>[:POWer]:SNUMber .....	6.47
SENSe<[1]...3>[:POWer]:SOURce .....	6.47
SENSe<[1]...3>[:POWer]:STATus[:DEVice]? .....	6.47
SENSe<[1]...3>[:POWer]:SVERsion .....	6.47
SENSe<[1]...3>[:POWer]:TYPE? .....	6.48
SENSe<[1]...3>[:POWer]:ZERO .....	6.48
SENSe<[1]...3>:UNIT[:POWer] .....	6.48
SOURce<[1] 2>:PRESet .....	6.7
STATus:OPERation:CONDition? .....	6.219
STATus:OPERation:ENABLE .....	6.219
STATus:OPERation:EVENT? .....	6.220
STATus:OPERation:NTRansition .....	6.220
STATus:OPERation:PTRansition .....	6.220
STATus:PRESet .....	6.220
STATus:QUESTionable:CONDition? .....	6.221
STATus:QUESTionable:ENABLE .....	6.222
STATus:QUESTionable:EVENT? .....	6.221
STATus:QUESTionable:NTRansition .....	6.221
STATus:QUESTionable:PTRansition .....	6.221
STATus:QUEue:NEXT]? .....	6.222
SYSTem:BEEPPer:STATe .....	6.223
SYSTem:COMMunicate:GPIB[:SELF]:ADDReSS .....	6.224
SYSTem:COMMunicate:GPIB:LTERminator .....	6.223
SYSTem:COMMunicate:NET:RESource? .....	6.224
SYSTem:DATE .....	6.224
SYSTem:DISPlay:UPDate .....	6.224
SYSTem:ERRor[:NEXT]? .....	6.226
SYSTem:ERRor:ALL? .....	6.225
SYSTem:ERRor:CODE[:NEXT]? .....	6.225
SYSTem:ERRor:CODE:ALL? .....	6.225
SYSTem:ERRor:COUNT? .....	6.226
SYSTem:FPReset .....	6.7
SYSTem:KLOCK .....	6.226
SYSTem:PRESet .....	6.226
SYSTem:PROTEct<n>[:STATe] .....	6.227
SYSTem:SERRor? .....	6.227
SYSTem:STARtup:COMPLete? .....	6.227
SYSTem:TIME .....	6.228
SYSTem:VERsion? .....	6.228
TEST<[1] 2>:BBOut:LRATe .....	6.229
TEST<[1] 2>:BBOut:TTEST:STATe .....	6.230
TEST<1 2>:DIRect .....	6.230
TEST:BB:CONNection? .....	6.229

---

TEST:CONNector:AUXio?.....	6.230
TEST:CONNector:BNC? .....	6.230
TRIGger<[1] 2>[:PSweep][:IMMediate].....	6.233
TRIGger<[1] 2>[:SWEep][:IMMediate].....	6.234
TRIGger<[1] 2>:FSweep[:IMMediate].....	6.232
TRIGger<[1] 2>:FSweep:SOURce .....	6.232
TRIGger<[1] 2>:LIST[:IMMediate] .....	6.233
TRIGger<[1] 2>:PSweep:SOURce .....	6.234
TRIGger<[1] 2>:SWEep:SOURce .....	6.235
TRIGger:BERT[:IMMediate] .....	6.16
TRIGger:BLER[:IMMediate].....	6.16
TRIGger0[:SWEep]:SOURce .....	6.231
UNIT:ANGLE .....	6.236
UNIT:POWer.....	6.236

# Index

## &

&GTL .....	5.3
&GTR .....	5.3
&LLO .....	5.3

## \*

*CLS .....	6.3
*ESE .....	6.3
*ESE? .....	6.3
*ESR? .....	6.3
*IDN? .....	6.4
*IST? .....	6.4
*OPC .....	6.4
*OPC? .....	6.4
*OPT? .....	6.4
*PRE .....	6.4
*PRE? .....	6.4
*PSC .....	6.4
*PSC? .....	6.4
*RCL .....	6.4
*RST .....	6.5,6.6
*SAV .....	6.5
*SRE .....	6.5
*SRE? .....	6.5
*STB? .....	6.5
*TRG .....	6.5
*TST? .....	6.5
*WAI .....	6.5

## .

...Current Frequency .....	4.7,6.18
...Full Range .....	4.7,6.18

## 0

0 - No error .....	9.8
--------------------	-----

## 1

-100 - Command Error .....	9.5
-101 - Invalid Character .....	9.7
-102 - Syntax error .....	9.10
-103 - Invalid separator .....	9.7
-108 - Parameter not allowed .....	9.8
-109 - Missing parameter .....	9.8
-112 - Program mnemonic too long .....	9.8
-113 - Undefined header .....	9.11
-114 - Header suffix out of range .....	9.6
-123 - Exponent too large .....	9.6

-124 - Too many digits .....	9.11
-128 - Numeric data not allowed .....	9.8
-131 - Invalid suffix .....	9.7
-134 - Suffix too long .....	9.10
-138 - Suffix not allowed .....	9.10
140 - This modulation forces other modulations off .....	9.15
-141 - Invalid character data .....	9.7
-144 - Character data too long .....	9.5
-148 - Character data not allowed .....	9.5
-158 - String data not allowed .....	9.10
-161 - Invalid block data .....	9.7
-168 - Block data not allowed .....	9.5
180 - Adjustment failed .....	9.12
182 - Adjustment data missing .....	9.12
183 - Adjustment data invalid .....	9.12

## 2

200 - Cannot access hardware .....	9.13
201 - Hardware revision out of date .....	9.14
202 - Cannot access the EEPROM .....	9.13
203 - Invalid EEPROM data .....	9.14
204 - Driver initialization failed .....	9.13
-221 - Settings conflict .....	9.9
-222 - Data out of range .....	9.5
-223 - Too much data .....	9.11
-224 - Illegal parameter value .....	9.7
-225 - Out of memory .....	9.8
-240 - Hardware error .....	9.6
-241 - Hardware missing .....	9.6
241 - No current list .....	9.14
242 - Unknown list type specified .....	9.15
261 - Waveform protected .....	9.15

## 3

-300 - Device-specific error .....	9.6
-310 - System error .....	9.10
-330 - Self-test failed .....	9.9
-350 - Queue overflow .....	9.9

## 4

-410 - Query deadlocked .....	9.9
-410 - Query interrupted .....	9.8
-410 - Query unterminated .....	9.9
460 - Cannot open file .....	9.13
461 - Cannot write file .....	9.13
462 - Cannot read file .....	9.13
463 - Filename missing .....	9.14
464 - Invalid filename extension .....	9.14
465 - File contains invalid data .....	9.14

## 5

50 - Extern reference out of range or disconnected .....	9.12
-------------------------------------------------------------	------

**A**

Abort button ..... 3.24  
 Aborting a calculation ..... 3.24  
 Accept - Setup ..... 4.24  
 Access denied ..... 3.14  
 Activating noise generator ..... 6.60  
 Add a program ..... 1.48  
 Additional White Gaussian Noise  
   (option R&S SMJ-K62) ..... 2.3  
 Additive Noise ..... 4.161, 4.162, 6.55, 6.57  
 Adjust All ..... 4.6, 6.17  
 Adjust Baseband Input ..... 6.17  
 Adjust FM Offset ..... 6.18  
 Adjust I/Q modulator ..... 4.7, 6.18  
 Adjust Level ..... 4.7, 6.19  
 Adjust Synthesis ..... 4.7, 6.18  
 Adjust Synthesis Extension ..... 4.7  
 Adjustment Active ..... 4.79, 6.197  
 Adjustment data invalid (183) ..... 9.12  
 Adjustment data missing (182) ..... 9.12  
 Adjustment failed (180) ..... 9.12  
 Adjustment Frequency ..... 4.79, 6.197  
 Adjustment Path A ..... 4.7  
 Adjustment value -  
   Reference frequency ..... 4.79, 6.197  
 ALC (automatic level control) ..... 4.84, 6.188  
 ALC On ..... 4.84  
 ALC-Auto ..... 9.3  
 ALC-Off ..... 9.3  
 ALC-On ..... 9.3  
 ALC-S&H ..... 9.3  
 AM Depth ..... 4.129, 6.50  
 AM External Coupling ..... 4.129, 6.51  
 AM External Impedance ..... 4.130, 6.206  
 AM Frequency ..... 4.130, 6.165  
 AM Sensitivity ..... 4.129, 4.132, 6.50, 6.51  
 AM Source ..... 4.129, 6.51  
 AM State ..... 4.129, 6.52  
 Analog Wideband I/Q In ..... 4.145, 6.210  
 Append - ARB ..... 4.260  
 Apply Assistant Settings -  
   ARB MCAR ..... 4.268, 6.76  
 ARB - Arbitrary  
   Waveform Generator ..... 4.235, 6.68  
 Architecture of R&S SMJ ..... 2.1  
 Arm Trigger - ARB ..... 6.82  
 Arm Trigger - ARB ..... 4.250  
 Arm Trigger - DM ..... 6.123, 4.230  
 Armed\_Auto - ARB ..... 4.249, 6.81  
 Armed\_Auto - DM ..... 6.121, 4.229  
 Armed\_Retrigger - ARB ..... 4.249, 6.81  
 Armed\_Retrigger - DM ..... 6.121, 4.229  
 Arrow keys ..... 1.9  
 ASCII file import/export - List Mode ..... 4.101  
 ASK Depth - DM ..... 6.112, 4.213  
 Assemblies display ..... 4.8, 6.22, 6.23  
 Assignment of marker signals - outputs ..... 1.10  
 Asterisk ..... 5.23

Attenuation - DM ..... 6.118, 4.227  
 Attenuator ..... 4.82, 6.39  
 Attenuator Mode ..... 4.82, 6.39  
 AttFixed ..... 9.3  
 Auto - ARB ..... 4.249, 6.81  
 Auto - DM ..... 6.121, 4.229  
 auto login ..... 1.26  
 Auto Once - Power Sensors ..... 4.91, 6.45  
 AUX I/O interface ..... 1.17, 4.18, 6.38, 6.205

**B**

B x T - DM ..... 6.114, 4.215  
 Baseband block menu ..... 4.183  
 Baseband Gain (I/Q) ..... 6.146, 4.152  
 Baseband generator  
   (option R&S SMJ-B10) ..... 2.3  
 Baseband main module  
   (option R&S SMJ-B13) ..... 2.3  
 Baseband Only - DM ..... 6.118, 4.227  
 Baseband selection ..... 2.3  
 Baseband Trigger Input Slope ..... 4.15, 6.206  
 BB-AM State ..... 4.132, 6.50  
 BERT (Bit Error Rate Tester) input ..... 1.17  
 Bias - I/Q out ..... 4.172, 6.211  
 Bit energy to noise power density ..... 4.165, 6.56  
 Bit Error Rate Measurement ..... 4.47, 6.8  
 Bit Rate - AWGN ..... 4.164, 6.53  
 BITCLK output ..... 4.19  
 BLER Type ..... 4.68, 6.13  
 Block data ..... 6.26, 5.22  
 Block data not allowed (-168) ..... 9.5  
 block diagram ..... 1.3  
 Block Error Rate Measurement ..... 4.47, 6.8  
 Boolean parameter ..... 5.22  
 Burst gate ..... 4.193  
 BURST input/output ..... 4.19  
 BUSY ..... 9.2

**C**

Cannot access hardware (200) ..... 9.13  
 Cannot access the EEPROM (202) ..... 9.13  
 Cannot open file (460) ..... 9.13  
 Cannot read file (462) ..... 9.13  
 Cannot write file (461) ..... 9.13  
 Carrier / Noise Ratio ..... 4.164, 4.165, 6.54  
 Carrier + Noise Level ..... 4.168, 6.59  
 Carrier + Noise PEP ..... 4.168, 6.59  
 Carrier Delay - ARB MCAR ..... 4.269  
 Carrier Gain - ARB MCAR ..... 4.269  
 Carrier Graph - ARB MCAR ..... 4.270  
 Carrier Index - ARB MCAR ..... 4.269  
 Carrier level - AWGN ..... 4.166, 6.57  
 Carrier Spacing - ARB MCAR ..... 4.265, 6.73  
 Carrier Start - ARB MCAR ..... 4.267, 6.78  
 Carrier State -  
   ARB MCAR ..... 4.267, 4.269, 6.74, 6.78

- Carrier Stop - ARB MCAR ..... 4.267,6.78  
Carrier Table Assistant -  
    ARB MCAR ..... 4.267,6.78  
Carrier Table button- ARB MCAR ..... 4.266  
CCDF display ..... 4.45  
Center Freq ..... 4.114,6.158  
Change Password - Setup ..... 4.23  
Channel x - ARB ..... 4.252  
Character data ..... 5.21  
Character data not allowed (-148) ..... 9.5  
Character data too long (-144) ..... 9.5  
Characters, special ..... 6.1  
Check Front Panel ..... 4.13  
Check-box field ..... 3.14  
Clock Frequency - ARB ..... 4.241,6.71  
Clock input slope ..... 4.15,6.20  
CLOCK input/output ..... 1.9  
Clock Mode - ARB ..... 4.254,6.71  
Clock Mode - DM ..... 6.113,4.233  
Clock Multiplier - ARB ..... 4.254,6.71  
Clock Multiplier - DM ..... 6.113,4.234  
Clock out mode ..... 4.15,6.20  
Clock out source ..... 6.21  
Clock output ..... 1.18  
Clock rate - ARB ..... 4.241  
Clock rate - ARB MCAR ..... 6.75  
Clock rate mode - ARB ..... 4.259,6.95  
Clock Reference ..... 4.189  
Clock Slope - BERT ..... 4.58,6.10  
Clock Slope - BLER ..... 4.69,6.10  
Clock Source - ARB ..... 4.254,6.72  
Clock Source - DM ..... 6.113,4.233  
CLOCK tag ..... 6.101  
Clock-Parameter - ARB ..... 4.254  
Coding - DM ..... 6.114,4.212  
Colon (separator) ..... 5.23  
Column Separator Import/Export -  
    List Mode data ..... 6.175  
Column Separator Import/Export -  
    User Correction data ..... 4.97,6.152  
Comma (separator) ..... 5.23  
Command  
    addressed ..... 8.5  
    description ..... 6.1  
    header ..... 5.18  
    Line ..... 5.20  
    parameters ..... 5.21  
    Query ..... 5.21  
    Question mark ..... 5.21  
    sequence ..... 5.27  
    structure ..... 5.18  
    synchronization ..... 5.27  
    universal ..... 8.5  
Command Error (-100) ..... 9.5  
COMMENT tag ..... 6.101  
Common commands ..... 6.3  
Configure Control Signal - DM ..... 4.223  
Confirm Password - Setup ..... 4.23  
Connected device -  
    Digital I/Q Output Settings ..... 4.178,6.214  
Connection to external controller ..... 1.39  
Constellation diagram ..... 4.43  
Control Lists - DM ..... 6.132,4.217  
Control Panel ..... 1.32  
Control signals ..... 4.193  
Controller, external ..... 1.39  
Copy - Data Editor ..... 4.221  
Copy instrument settings ..... 4.33,6.34  
Counter ..... 4.8,6.23  
Couple I/Q Bias ..... 4.172  
Coupling mode - EXT MOD (AM) ..... 4.129,6.51  
Coupling mode - EXT MOD (FM) ..... 4.137,6.156  
Coupling mode - EXT MOD (PhiM) ..... 4.141  
Coupling mode - EXT MOD (PM) ..... 6.184  
CRC Order - BLER ..... 4.68,6.10  
Create - ARB ..... 4.260  
Create - ARB MCAR ..... 4.271  
Create and Load - ARB ..... 4.260,4.271  
Create Multi Carrier Waveforms - ARB ..... 4.263  
Create Multi Segment Waveforms - ARB ..... 4.257  
Create New Directory ..... 4.34  
Crest factor - baseband ..... 4.179,6.64  
Crest factor - Baseband  
    Signal Level Measurement ..... 4.181,6.61  
Crest factor (I/Q) ..... 4.151,6.208  
Crest Factor Mode - ARB MCAR ..... 4.265,6.74  
Cross-over RJ-45 cable ..... 1.31  
Current Freq (LF Sweep) ..... 4.123,6.165  
Current Freq (RF Sweep) ..... 4.114,6.160  
Current Level ..... 4.119,6.190  
Current Range  
    without Recalculation - ARB ..... 4.254,6.85  
Current Range  
    without Recalculation - DM ..... 6.126,4.233  
Current Segment - ARB ..... 4.241  
Cursor Length - DM ..... 4.224  
Cursor Position - DM ..... 4.225  
Custom Digital Modulation ..... 6.110,4.196  
Cut 4.33  
Cut - Data Editor ..... 4.221  
Cut Off Frequency Factor - DM ..... 4.215  
CW (continuous wave) ..... 4.193  
CW Interferer ..... 4.161  
CW MODE - Input ..... 4.18  
CW Switching - DM ..... 6.123,4.214
- ## D
- Data Bits - BERT ..... 4.53,6.9  
Data Enable - BERT ..... 4.60,6.11  
Data Enable - BLER ..... 4.69  
Data format - block data ..... 6.26  
Data format - query command ..... 6.26  
DATA input/output ..... 1.9,4.18  
Data List ..... 4.187  
Data Lists - DM ..... 6.135,4.217

- Data out of range (-222) ..... 9.5  
 Data pattern - DM ..... 6.117,4.209  
 Data Polarity - BERT ..... 4.58,6.11  
 Data Polarity - BLER ..... 4.68,6.11  
 Data Source - DM ..... 6.121,4.209  
 Data/Control List Management - DM ..... 4.210  
 DCL ..... 5.24  
 Decimal point ..... 5.21  
 Decimal Point Import/Export -  
     List Mode data ..... 4.108,6.175  
 Decimal Point Import/Export -  
     User Correction data ..... 4.97,6.153  
 Default factory settings ..... 6.7  
 Default instrument settings ..... 1.25,4.4,6.226  
 Default settings - ARB ..... 4.239,6.81  
 Default settings - ARB MCAR ..... 4.264,6.79  
 Default settings - DM ..... 6.120,4.207  
 Delay - Falling Edge of  
     Ramp Envelope - DM ..... 6.118,4.227  
 Delay - Marker - ARB ..... 4.253,6.84  
 Delay - Marker - DM ..... 6.126,4.232  
 Delay - Rising Edge of  
     Ramp Envelope - DM ..... 6.118,4.227  
 Delay - Trigger - ARB ..... 4.251,6.83  
 Delay - Trigger - DM ..... 6.124,4.231  
 Delay Start - ARB MCAR ..... 4.268,6.72,6.75  
 Delay Step - ARB MCAR ..... 4.268,6.76  
 Delete - ARB ..... 4.260  
 Delete instrument settings ..... 4.34,6.35  
 Delimiter ..... 5.24  
 Delta Phase ..... 4.74,6.183  
 Destination Import/Export -  
     List Mode data ..... 4.108,6.177  
 Destination Import/Export -  
     User Correction data ..... 4.97,6.154  
 Deviation - FSK Modulation - DM ..... 6.116,4.213  
 Deviation - Variable  
     FSK Modulation - DM ..... 6.117,4.214  
 Device reset ..... 6.6  
 Device-specific error (-300) ..... 9.6  
 DHCP ..... 1.31  
 Differential coding - DM ..... 6.114  
 Differential coding - DM ..... 4.212  
 Differential I/Q-Outputs ..... 6.211  
 Differential output ..... 4.170  
 Differential output  
     (option R&S SMJ-B16) ..... 1.15  
 Digital I/Q Output - EX-IQ-Box Settings ..... 4.174  
 Digital I/Q Output Level - I/Q OUT ..... 6.216  
 Digital I/Q Output PEP - I/Q OUT ..... 4.176,6.216  
 Digital I/Q Output Power-  
     On State - I/Q OUT ..... 4.178,6.215  
 Digital I/Q Output Sample Rate -  
     I/Q OUT ..... 6.217  
 Digital I/Q Output State -  
     I/Q OUT ..... 4.174,6.218  
 Digital I/Q Output Step width -  
     I/Q OUT ..... 4.177,6.216  
 Digital I/Q Output  
     Variation Active - I/Q OUT ..... 4.177,6.216  
 Digital I/Q Output  
     Variation Step - I/Q OUT ..... 4.177,6.216  
 Digital I/Q-Output-I/QOUT ..... 6.214  
 Digital Modulation ..... 6.110,4.196  
 Directory ..... 4.31,6.33  
 Display ..... 1.3,3.7  
 Display I/Q Output Level Via -  
     I/Q OUT ..... 4.176,6.217  
 Display Mode - AWGN ..... 4.162,6.55  
 Display Output Results - AWGN ..... 4.162,6.55  
 Double dagger ..... 5.23  
 Driver initialization failed (204) ..... 9.13  
 Duration - Baseband Signal Level  
     Measurement ..... 4.180,6.61  
 Dwell Time - Level Sweep ..... 4.119,6.202  
 Dwell Time - LF Sweep ..... 4.124,6.167  
 Dwell time - List Mode ..... 4.104,6.177  
 Dwell Time - List Mode ..... 4.104,6.177  
 Dwell Time - RF Sweep ..... 4.115,6.199
- ## E
- Edge form of  
     ramp envelope - DM ..... 6.119,4.226  
 Edge slope of  
     ramp envelope - DM ..... 6.119,4.227  
 Edit User Correction Data ..... 4.94  
 EMF - Level display ..... 4.83  
 Enable/disable beep ..... 6.223  
 Entry field ..... 3.13  
 EOI (command line) ..... 5.20  
 Error messages ..... 9.4,9.5,3.8  
 Error messages - display list ..... 6.227  
 Error queue ..... 5.34  
 Error queue query ..... 6.222,6.225,6.226  
 Errors - BERT ..... 4.53,6.9  
 Errors - BLER ..... 4.64,6.9  
 ESE (event status enable register) ..... 5.32  
 Ethernet ..... 1.30  
 Event status enable register (ESE) ..... 5.32  
 Example for setting ..... 2.8  
 Exclude Frequency ..... 4.31,6.159  
 Exclude Level ..... 4.32,6.190  
 Execute  
     Baseband Connection Selftest ..... 4.12,6.229  
 Execute Single - List Mode ..... 4.104,6.181  
 Execute Single Sweep -  
     Frequency Sweep ..... 4.113,6.199  
 Execute Single Sweep -  
     Level Sweep ..... 4.118,6.202  
 Execute Single Sweep -  
     LF Sweep ..... 4.122,6.167  
 Execute Trigger - ARB ..... 4.247,6.83  
 Execute Trigger - DM ..... 6.124,4.216  
 EX-IQ-Box Settings - Digital I/Q Output ..... 4.174  
 Expiration date of option ..... 4.10

Exponent..... 5.21  
 Exponent too large (-123)..... 9.6  
 EXT MOD ..... 1.16  
 EXT REF..... 9.2  
 EXT TUNE input..... 4.19,4.78  
 Extended Trigger Mode - ARB ..... 4.241,4.242  
 Extension Import/Export -  
   List Mode data ..... 4.108,6.174,6.175  
 Extension Import/Export -  
   User Correction data..... 4.97,6.151,6.152  
 Extern reference out of range  
   or disconnected (50)..... 9.12  
 External Input Impedance..... 4.134,6.206  
 External modulation data..... 4.188  
 External modulation signal - FM..... 4.135  
 External modulation signal - PhiM..... 4.139  
 External modulation signal -  
   voltage ..... 4.126,4.128  
 External Reference Frequency..... 4.79,6.196  
 External Restart - BERT..... 4.59,6.13  
 External Trigger Delay - ARB..... 4.251,6.83  
 External Trigger Delay - DM..... 6.124,4.231  
 External Trigger Inhibit - ARB ..... 4.252,6.83  
 External Trigger Inhibit - DM..... 6.125,4.231  
 External tuning - Reference frequency..... 4.78  
 Eye diagram..... 4.44

**F**

Factory Preset ..... 4.24  
 Fall Delay - DM..... 6.118,4.227  
 FIFO Status -  
   Digital I/Q Output Settings ..... 4.175,6.217  
 FIFO Status - OK..... 4.175,6.217  
 FIFO Status - Overflow..... 4.175,6.217  
 FIFO Status - Underrun..... 4.175,6.217  
 File - ARB MCAR..... 4.269,6.72,6.76  
 File contains invalid data (465)..... 9.14  
 File list..... 4.31,6.32  
 File Management - ARB ..... 4.240  
 File menu ..... 4.29  
 File size - ARB MCAR ..... 6.79  
 File type selection..... 4.33  
 Filename missing (463) ..... 9.14  
 Fill Table - List mode ..... 4.106,4.109  
 Fill Table From..... 4.109  
 Fill Table Range ..... 4.98,4.109  
 Filter - DM ..... 6.116,4.215  
 Filter - Power Sensors ..... 4.90  
 Filter Length - Power Sensors ..... 4.91,6.44,6.45  
 Filter Parameter - DM ..... 6.114,4.215  
 Fine adjustment -  
   Reference frequency ..... 4.79,6.197  
 Firewall ..... 1.36  
 Firmware update..... 1.20  
 Firmware version ..... 4.10,6.4  
 Fix marker delay to  
   current range - ARB..... 4.254,6.84

Fix marker delay to  
   current range - DM..... 6.126,4.233  
 FM Deviation..... 4.137,6.156  
 FM External Coupling ..... 4.137,6.156  
 FM External Impedance..... 4.138,6.206  
 FM Frequency..... 4.138  
 FM Mode..... 4.136,6.157  
 FM Sensitivity..... 4.137,6.157  
 FM Source ..... 4.136,6.157  
 FM State..... 4.136,6.157  
 FREQ OFFSET..... 9.1  
 Frequency - AM ..... 4.130,6.165  
 Frequency - FM..... 4.138  
 Frequency - List mode ..... 4.105,6.177  
 Frequency - PhiM..... 4.142  
 Frequency - PM ..... 4.134,6.165  
 Frequency - Power Sensors ..... 4.90  
 Frequency - RF output signal ..... 4.72,6.159  
 Frequency - RF Sweep ..... 4.113,6.162  
 Frequency - Test Signal ARB ..... 4.256,6.90  
 Frequency display..... 3.7  
 Frequency Offset ..... 4.74,6.161  
 Frequency Offset - Baseband..... 4.183,6.65  
 Front panel key emulation..... 3.45  
 FSK Deviation - DM ..... 6.116,4.213  
 FSK Type (Variable FSK) - DM ..... 6.117,4.214  
 Fuses ..... 1.23

**G**

Gain - ARB MCARrier..... 6.73  
 Gain (I/Q) ..... 4.152,6.208  
 Gain Start - ARB MCAR..... 4.267  
 Gain Step - ARB MCAR..... 4.268  
 Generate Signal HD -  
   Test Signal ARB..... 4.256,6.89  
 Generate Signal RAM -  
   Test Signal ARB..... 4.256,6.90  
 GET (Group Execute Trigger)..... 5.25  
 Getting started ..... 2.1  
 Global Trigger/Clock/External Inputs ..... 4.13  
 GPIB..... 4.20  
 Graphical display of output signal..... 4.35  
 Graphics block ..... 2.5,4.35

**H**

Hardware Config ..... 4.8,6.22  
 Hardware error (-240)..... 9.6  
 Hardware missing (-241)..... 9.6  
 Hardware options..... 4.9,6.4  
 Hardware revision out of date (201) ..... 9.14  
 Header ..... 5.18  
 Header suffix out of range (-114)..... 9.6  
 High Accuracy Level Adjustment ..... 4.7,6.19  
 HOP (hopping) ..... 4.17

## I

I BAR	1.15
I input	1.9
I/Q diagram	4.41
I/Q File - ARB MCAR	6.72, 6.76
I/Q Mod block	2.6
I/Q modulation	4.143, 4.145, 6.210
I/Q modulation - baseband gain	6.146, 4.152
I/Q modulation - Crest factor	4.151, 6.208
I/Q modulation - gain	4.152, 6.208
I/Q modulation - Impairments	4.146, 6.210
I/Q Out OFF	9.2
I/Q Swap - I/Q	4.150, 6.210
I/Q Wideband - I/Q	4.151, 6.210
I/Q Output Type - I/Q out	4.170
ICMP Ping - LXI	5.14
IEC/IEEE bus	
command description	6.1
Interface	1.16
IEC/IEEE-bus address	4.20, 6.224
Illegal parameter value (-224)	9.7
Imbalance - I/Q analog	4.148, 6.209
Imbalance - I/Q digital	6.144, 4.157
Impairments analog	4.146, 6.210
Impairments digital	
....	6.146, 4.154, 4.180, 4.181, 6.61, 6.62, 6.63
Impedance - BERT	4.59, 6.15
Impedance - BLER	4.69, 6.15
Impedance -	
EXT MOD..	4.130, 4.134, 4.138, 4.142, 6.206
Impedance - RF outputs	6.40
Impedance data input (ser/par)	4.14, 6.205
Impedance trigger/control	
signal input (ser/par)	4.15, 6.206
Import/Export -	
List Mode data	4.107, 4.108, 6.176
Import/Export -	
User Correction data	4.96, 4.97, 6.153
INFO key	3.9
Input - BERT	1.17
Input - BURST	4.19
Input - CLOCK	1.9
Input - CW MODE	4.18
Input - DATA	1.9, 4.18
Input - EXT MOD	1.16, 4.133
Input - EXT TUNE	4.19
Input - I signal	1.9
Input - INST TRIG	1.18
Input - LEV-ATT	4.18
Input - Q signal	1.9
Input - REF IN	1.16
Input - TRIGGER 1	1.10
Input - TRIGGER 2	1.19
Input - USER	1.19
Input buffer	5.24
Input Waveform File - ARB MCAR	4.268
Install SW-Option	4.10
Instrument Config	4.8, 6.22

Instrument Home Page - LXI	5.12
Instrument settings - recall	4.31, 6.4, 6.36
Instrument settings - save	4.29, 6.5, 6.37
Instrument trigger input slope	4.15, 6.207
Interface - AUX I/O	1.17, 4.18
Interface - IEC/IEEE bus	1.16
Interface function IEC/IEEE bus	8.4
Internal Baseband I/Q In	4.145, 6.210
internalBaseIdLmod	4.109
internalBaseIdUcor	4.98
internalColumnIdLmod	4.109
internalColumnIdUcor	4.98
internalEndIdLmod	4.109
internalEndIdUcor	4.98
internalFillIdLmod	4.109
internalFillIdUcor	4.98
internalIncrementId	4.98, 4.109
internalIncrementIdLmod	4.109
internalIncrementIdUcor	4.98
internalLiTaFillDialogRangeldLmod	4.109
internalLiTaFillDialogRangeldUcor	4.98
internalLiTaFillDialogStartIdLmod	4.109
internalLiTaFillDialogStartIdUcor	4.98
internalOptionKey	4.10
Internet Connection Firewall	1.36
Internet Protocol TCP/IP) Properties	1.34
Interrupt	5.33
Invalid block data (-161)	9.7
Invalid Character (-101)	9.7
Invalid EEPROM data (203)	9.14
Invalid filename extension (464)	9.14
Invalid separator (-103)	9.7
Invalid suffix (-131)	9.7
IP address	1.32
IST flag	6.4

## K

Key - $\mu$ V	1.6
Key - 1x/Enter	1.6
Key - A, B, C, D, E, F	1.4
Key - alphanumeric keys	1.4
Key - BACKSPACE	1.5
Key - dB(m)	1.6
Key - dB $\mu$ V	1.6
Key - DIAGRAM	1.8
Key - Enter	1.6
Key - ENTER	1.5
Key - ESC	1.8
Key - FILE	4.28
Key - G/n	1.6
Key - HCOPY	1.12, 4.25
Key - HELP	1.12, 4.26
Key - INFO	1.12
Key - INSERT	1.5
Key - k/m	1.6
Key - LOCAL	1.12, 4.25
Key - M/ $\mu$	1.6



Key - MENU..... 1.8  
 Key - MOD ON/OFF ..... 1.7  
 Key - numeric keys ..... 1.4  
 Key - ON/OFF TOGGLE..... 1.8  
 Key - PRESET ..... 1.12,1.25,4.4  
 Key - Setup ..... 4.5  
 Key - SETUP ..... 1.12  
 Key - Unit key ..... 1.5  
 Key combinations ..... 3.44  
 keyboard assignment - language ..... 1.28  
 keyboard assignment - refresh rate..... 1.28  
 keyboard emulation ..... 1.28  
 Keyboard emulation..... 3.46  
 Keyboard Language - Setup..... 6.28  
 Keyboard Layout - Setup..... 4.16,6.28

**L**

LAN ..... 1.30,5.5,8.6  
 LAN - Interface..... 8.6  
 LAN Configuration - LXI..... 5.12  
 LAN Connection - Setup..... 4.24  
 LAN Status - LXI..... 4.21  
 Language Keyboard - Setup..... 6.28  
 Layout Keyboard - Setup..... 4.16,6.28  
 Leakage - I/Q digital ..... 6.145,4.155  
 Learn List Mode Data ..... 4.104,6.179  
 LEV ATT - Input/output..... 4.18  
 Level - Power Sensors ..... 4.88  
 Level - RF output ..... 4.81,6.189  
 Level - Step width ..... 4.83,6.192  
 Level - Uninterrupted setting ..... 4.82,6.39  
 Level - Unit..... 4.80  
 Level attenuation ..... 4.193  
 Level Attenuation - DM..... 6.118,4.227  
 Level control ..... 4.84,6.188  
 Level display..... 3.7  
 Level display EMF ..... 4.83  
 Level EMF - I/Q out ..... 4.172,6.212  
 Level limit..... 4.82,6.190  
 Level mode - ARB ..... 4.258,6.96  
 Level offset ..... 4.82,6.189  
 LEVEL OFFSET ..... 9.2  
 Level Offset - Power Sensors..... 4.90  
 Level Sweep ..... 4.116,6.191  
 Level user correction ..... 4.92,6.147  
 LevelSweep ..... 9.3  
 LF Gen Frequency..... 4.125,6.165  
 LF Gen Voltage ..... 4.125,6.170  
 LF generator ..... 4.125,6.164  
 LF output..... 1.14,4.125,6.164  
 LF Output State ..... 4.125,6.166  
 LF Sweep..... 4.123,6.166  
 LFSweep..... 9.3  
 Licence for software option..... 4.10  
 Limit - Level ..... 4.82,6.190  
 Linux controller ..... 1.45  
 List Management - DM ..... 4.210

List mode..... 4.101,6.171,6.191  
 List mode - manual processing of lists..... 4.103  
 List Mode Data ..... 4.105  
 List Range In..... 4.107,6.178  
 ListMode..... 9.3  
 Load instrument settings..... 4.31,6.4,6.36  
 Load User Filter - DM..... 4.216  
 Load User Mapping - DM ..... 6.141,4.212  
 Load Waveform - ARB ..... 4.240,6.92,6.93  
 LOC LLO..... 9.3  
 Local - Remote Channel Control ..... 4.20  
 Local Area Connection Properties ..... 1.34  
 LOCAL key..... 5.4  
 Local to remote switchover ..... 5.3  
 Lock keyboard..... 6.226  
 Lower case..... 6.1  
 Lower-case (commands) ..... 5.19  
 LVDS Rate Selftest ..... 4.12,6.229  
 LXI 4.21  
 LXI Glossary - LXI..... 5.12

**M**

Maintenance ..... 8.2  
 Mantissa..... 5.21  
 Manual control switch-over ..... 4.25  
 Manual operation return to..... 5.4,5.9  
 Manual remote control ..... 1.39  
 Manual Trigger - ARB ..... 4.247,6.83  
 Manual trigger - DM ..... 6.124,4.216  
 Map output connector user x to ..... 4.19  
 Marker outputs ..... 1.10  
 Marker CH x - ARB ..... 6.85  
 Marker Channel x - DM..... 6.127,4.231  
 Marker Delay - ARB ..... 4.253,6.84  
 Marker Delay - DM..... 6.126,4.232  
 MARKER output..... 4.19  
 Marker output signals..... 4.195  
 Marker Positions - DM ..... 4.225  
 Max Data Bits - BERT..... 4.57,6.12  
 Max Errors - BERT..... 4.58,6.12  
 Max Errors - BLER..... 4.68,6.12  
 Max Received Blocks - BLER..... 4.68,6.12  
 Maximal deviation - FM..... 4.137,6.156  
 Maximal deviation - PhiM..... 4.141  
 Maximal deviation - PM..... 6.184  
 Measured External Clock - ARB ..... 4.255  
 Measured External Clock - DM..... 4.234  
 Menu area ..... 3.14  
 Menu header ..... 3.13  
 Minimum Noise/System  
     Bandwidth Ratio - AWGN..... 4.162,6.54  
 Missing parameter (-109)..... 9.8  
 MOD OFF..... 9.1  
 Mode - BERT ..... 4.57,6.10  
 Mode - BLER ..... 4.67,6.10  
 Mode - FM..... 4.136,6.157  
 Mode - I/Q out..... 6.213

Mode - Level Sweep ..... 4.117, 6.191, 6.203  
 Mode - LF Gen ..... 4.121, 6.165  
 Mode - LF Sweep ..... 4.121, 6.165, 6.167  
 Mode - List Mode ..... 4.102, 6.179  
 Mode - PhiM ..... 4.140  
 Mode - PM ..... 6.185  
 Mode - RF Frequency ..... 4.111, 6.160  
 Mode - RF Sweep ..... 4.111, 6.160, 6.200  
 Mode Import/Export -  
     List Mode data ..... 4.108, 6.176  
 Mode Import/Export -  
     User Correction data ..... 4.97, 6.154  
 Modulation - AM ..... 4.128, 6.49  
 Modulation - BB-AM ..... 4.132, 6.50  
 Modulation - DM ..... 4.213  
 Modulation - FM ..... 4.135, 6.156  
 Modulation - I/Q ..... 4.145, 6.208, 6.210  
 Modulation - PhiM ..... 4.139  
 Modulation - PM ..... 6.184  
 Modulation - Pulse modulation ..... 4.133, 6.194  
 Modulation data external ..... 4.188  
 Modulation Delay for ext. Data -  
     DM ..... 6.117, 4.214  
 Modulation depth - AM ..... 4.129, 6.50  
 Modulation depth - PhiM ..... 4.141  
 Modulation deviation - FM ..... 4.137, 6.156  
 Modulation deviation - PM ..... 6.184  
 Modulation input ..... 1.16  
 Modulation Type - DM ..... 6.116, 4.212  
 Multi Carrier Waveforms - ARB ..... 4.263  
 Multi Segment table - ARB ..... 4.258  
 Multi Segment Waveforms - ARB ..... 4.257  
 Multiplier - ARB ..... 4.254, 6.71  
 Multiplier - DM ..... 6.113, 4.234  
 Multi-transmitter measurements ..... 4.84

## N

Negotiation - LXI ..... 5.14  
 Network and Internet Connections ..... 1.33  
 Network card ..... 1.30  
 Network Connections ..... 1.33  
 Network drives ..... 1.37  
 New list- ARB ..... 4.261  
 New Password - Setup ..... 4.23  
 Next Segment - ARB ..... 4.246  
 No Clock BERT ..... 4.55, 6.9  
 No Clock BLER ..... 4.66, 6.9  
 No current list (241) ..... 9.14  
 No error (0) ..... 9.8  
 No Sync BERT ..... 4.56, 6.9  
 No Sync BLER ..... 4.67, 6.9  
 Noise Bandwidth - AWGN ..... 4.162, 6.54  
 Noise generator ..... 4.159, 6.53  
 Noise generator, switching on ..... 4.161  
 Noise level - AWGN ..... 4.166, 6.58  
 Noise level Total Bandwidth -  
     AWGN ..... 4.168, 6.58

Noise Only ..... 4.161, 4.162, 6.55, 6.57  
 No-load voltage (EMF) ..... 4.83  
 Norton Antivirus 2005 ..... 1.52  
 Number of Carriers - ARB MCAR ..... 4.264  
 Number of Carriers - ARB MCARr ..... 6.72  
 Number of licences ..... 4.10  
 Numeric data not allowed (-128) ..... 9.8  
 Numeric suffix ..... 5.19

## O

Offset - Frequency ..... 4.74, 6.161  
 Offset - I/Q analog ..... 4.146, 6.209  
 Offset - I/Q out ..... 4.173, 6.213  
 Offset - Level ..... 4.82, 6.189  
 Old password - Setup ..... 4.23  
 ON/OFF Ratio Marker - ARB ..... 4.253, 6.86  
 ON/OFF Ratio Marker - DM ..... 6.127, 4.232  
 Operation hours ..... 4.8, 6.23  
 Optimization mode ..... 4.159  
 Optimize Crest Factor -  
     ARB MCAR ..... 4.265, 6.74  
 Optimize I/Q-Signals  
     for RF Output ..... 4.170, 6.212  
 Optimize internal I/Q-Impairments  
     for RF Output ..... 6.145, 4.159  
 Option  
     ARB-Baseband Generator (B9/B10/B11) ..... 4.235  
     Baseband Generator (B9/B10/B11) ..... 4.182  
     Baseband Main Module (B13) ..... 4.182  
     DM-Baseband Generator (B9/B10/B11) ..... 4.196  
     expiration date ..... 4.10  
     listing ..... 4.9, 6.4  
     Rear Panel Connectors (B81) ..... 1.15  
 Option - R&S SMJ-B16  
     (Differential Output) ..... 4.170  
 Out of memory (-225) ..... 9.8  
 Output - BITCLK ..... 4.19  
 Output - BURST ..... 4.19  
 Output - CLOCK ..... 1.9, 1.18  
 Output - DATA ..... 1.9, 4.18  
 Output - I BAR ..... 1.15  
 Output - LEV-ATT ..... 4.18  
 Output - LF ..... 1.14, 4.125, 6.164  
 Output - MARKER ½ ..... 1.10  
 Output - MARKER 4 ..... 4.19  
 Output - Q BAR ..... 1.15  
 Output - REF OUT ..... 1.15  
 Output - RF ..... 1.10  
 Output - SYMBCLK ..... 4.19  
 Output - TRIG OUT ..... 1.14  
 Output - USER ..... 1.19  
 Output File - ARB ..... 4.259  
 Output File - ARB MCAR ..... 4.270  
 Output Mode - IQ Out ..... 4.171  
 Output Type - IQ out ..... 6.213  
 Output Voltage - LF output ..... 4.125  
 OvenCold ..... 9.3

Overflow -  
     Digital I/Q Output Settings ..... 4.177,6.215  
 Overflow Hold -  
     Digital I/Q Output Settings ..... 4.178,6.215  
 Overlapping execution ..... 5.25  
 OVERLOAD ..... 9.2,4.100  
 Overvoltage protection ..... 4.100,6.40

**P**

Parallel Poll ..... 5.33  
 Parameter (commands) ..... 5.21  
 Parameter not allowed (-108) ..... 9.8  
 Part numbers ..... 4.8  
 password ..... 1.26  
 Paste ..... 4.33  
 Paste – Data Editor ..... 4.221  
 Path - Test point ..... 4.11  
 Path Gain - Baseband ..... 4.185,6.66  
 Path reset ..... 6.7  
 Pattern - DM ..... 6.117,4.209  
 Pattern Ignore - BERT ..... 4.61,6.11  
 PCI bus ..... 4.8  
 Peak envelope power PEP ..... 3.7  
 Peak Level - Baseband Signal Level  
     Measurement ..... 4.181,6.62  
 Peak level of baseband ..... 4.179,6.64  
 Phase - RF output signal ..... 4.74,6.183  
 Phase continuous Active - RF Signal ..... 6.161  
 Phase Offset - Baseband ..... 6.66  
 Phase Offset Q - Test Signal ARB ..... 4.256,6.90  
 Phase Start - ARB MCAR ..... 4.268,6.73  
 Phase Step - ARB MCAR ..... 4.268,6.77  
 PhiM Depth ..... 4.141  
 PhiM External Coupling ..... 4.141  
 PhiM External Impedance ..... 4.142,6.206  
 PM Deviation ..... 6.184  
 PM External Coupling ..... 6.184  
 PM Frequency ..... 4.134,4.142,6.165  
 PM Mode ..... 4.140,6.185  
 PM Sensitivity ..... 4.141,6.185  
 PM Source ..... 4.140,6.185  
 PM State ..... 4.140,6.186  
 Point-to-point connection ..... 1.31,1.37  
 Polarity - No signal (blank) marker ..... 4.19,6.39  
 Polarity - Pulse Modulation ..... 4.134,6.194  
 Power - List mode ..... 4.105  
 Power of starting carrier - ARB MCAR ..... 4.267  
 Power of starting carrier -  
     ARB MCARrier ..... 6.73  
 Power ramping ..... 4.193  
 Power ramping - DM ..... 6.119,4.226  
 Power spectrum ..... 4.46  
 Power Start - ARB MCARrier ..... 6.73  
 Power Step - ARB MCAR ..... 6.77  
 Power Viewer ..... 1.26  
 Power-On Counter ..... 4.8,6.23  
 Power-On State ..... 4.83,6.41

PPE (Parallel poll enable register) ..... 5.31  
 PRBS - BERT ..... 4.58,6.13  
 PRBS generator ..... 4.186  
 PRBS Type - DM ..... 6.120,4.209  
 Preset - factory settings ..... 6.7  
 Preset -  
     instrument settings ..... 1.25,4.4,6.6,6.226  
 Program mnemonic too long (-112) ..... 9.8  
 Protect RF Output - ALC ..... 4.85,6.40  
 Protection ..... 4.22  
 PSK 4.196  
 Pulse Divider Marker - ARB ..... 4.252,6.87  
 Pulse Divider Marker - DM ..... 6.128,4.231  
 Pulse External Impedance ..... 4.134,6.206  
 Pulse Frequency Marker - ARB ..... 4.252,6.87  
 Pulse Frequency Marker - DM ..... 6.129,4.231  
 Pulse modulation ..... 4.133,6.194  
 Pulse modulation -  
     repetition frequency ..... 4.134,6.165

**Q**

Q BAR ..... 1.15  
 Q input ..... 1.9  
 QAM ..... 4.196  
 Quadrature Offset - I/Q analog ..... 4.149,6.209  
 Quadrature Offset - I/Q digital ..... 6.145,4.158  
 Query ..... 5.16  
     responses ..... 5.21  
 Query deadlocked (-430) ..... 9.9  
 Query interrupted (-410) ..... 9.8  
 Query unterminated (-420) ..... 9.9  
 Question ..... 5.23  
 Queue overflow (-350) ..... 9.9  
 Quotation marks ..... 5.23

**R**

Rack installation ..... 1.20  
 Ramp Function - DM ..... 6.119,4.226  
 Ramp Time - DM ..... 6.119,4.227  
 Ratio Noise/System Bandwidth -  
     AWGN ..... 4.162,6.54  
 Rear Panel Connectors (B81) ..... 1.15  
 Recall instrument settings ..... 4.31,4.32,6.4,6.36  
 Recall Intermediate ..... 4.32,6.4  
 Received Blocks - BLER ..... 4.64,6.9  
 Recent data sets ..... 4.31  
 REF IN ..... 1.16  
 REF OUT ..... 1.15  
 REF OUT output ..... 4.78  
 Reference frequency - external ..... 4.79,6.196  
 Reference frequency  
     adjustment mode ..... 4.79,6.197  
 Reference Level - AWGN ..... 4.164  
 Reference Mode - AWGN ..... 6.59  
 Reference oscillator ..... 4.78,6.196  
 REM LLO ..... 9.2

- Remaining Time - Baseband Signal  
     Level Measurement ..... 4.181,6.62  
 Remot Desktop Connection ..... 1.42  
 REMOTE ..... 9.2  
 Remote Control - GPIB ..... 5.4  
 Remote control - manual ..... 1.39  
 Remote control basics ..... 5.1  
 Remote control switchover ..... 5.3  
 Remote Desktop ..... 1.39  
 Remote Desktop Connection –  
     Display tab ..... 1.43  
 Remote Desktop Connection –  
     General tab ..... 1.42  
 Remote to local switchover ..... 5.3  
 Rename ..... 4.34,6.36  
 Reset - Digital I/Q  
     Output Settings ..... 4.178,6.214  
 Reset Delta Phase Display ..... 4.74,6.183  
 Reset device parameters ..... 6.6  
 Reset factory settings ..... 6.7  
 Reset instrument settings ..... 1.25,4.4,6.6,6.226  
 Reset path ..... 6.7  
 Reset status reporting system ..... 5.35  
 Restoring the previous value ..... 3.25  
 Result - BERT ..... 4.53,6.9  
 Result - BLER ..... 4.64,6.9  
 Resulting CW Frequency - AWGN ..... 4.163,6.56  
 Resulting I/Q Level EMF ..... 4.172,6.212  
 Retrigger - ARB ..... 4.249,6.81  
 Retrigger - DM ..... 6.121,4.229  
 Revisions ..... 4.8  
 RF frequency ..... 4.73,6.158,6.159  
 RF OFF ..... 9.1  
 RF ON/OFF key ..... 4.70,6.41  
 RF output - Power-on state ..... 4.83,6.41  
 RF output level ..... 4.81,6.189  
 RF output signal - Phase adjustment 4.74,6.183  
 RF section ..... 2.3  
 RF/A Mod block ..... 2.6  
 RFI signal generator, switching on ..... 4.161  
 RFSweep ..... 9.3  
 Rise Delay - DM ..... 6.118,4.227  
 RJ-45 cable ..... 1.30  
 Roll off factor - DM ..... 6.114,4.215  
 Rotary knob ..... 1.8  
 Route to path A/B ..... 4.185,6.67  
 Running - Trigger - ARB ..... 4.250,6.87,6.89  
 Running - Trigger - DM ..... 6.129,4.230
- S**
- Sample Clock Multiplier - ARB ..... 4.254  
 Sample Rate Source -  
     Digital I/Q Output Settings ..... 4.175,6.218  
 Sample Rate Value-  
     Digital I/Q Output Settings ..... 4.175  
 Sample-and-Hold mode ..... 4.84,6.188  
 Samples per Period -  
     Test Signal ARB ..... 4.256,6.90  
 Save - DM ..... 4.221,4.225  
 Save As - DM ..... 4.225  
 Save immediate ..... 4.30,6.5  
 Save instrument settings ..... 4.30,6.5,6.37  
 Save/Recall - ARB MCAR ..... 4.264  
 SCPI - conformity information ..... 6.1  
 SCPI - error messages ..... 9.5  
 SCPI - version ..... 5.1  
 Screen Saver - Setup ..... 4.16,6.25  
 Search Once - ALC ..... 4.85,6.188  
 Security Password - Setup ..... 4.24  
 Segment #- ARB ..... 4.258  
 Select ASCII Destination -  
     List Mode data ..... 4.108  
 Select ASCII Destination -  
     User Correction data ..... 4.97  
 Select ASCII Source -  
     User Correction data ..... 4.97  
 Select List ..... 4.105,6.180  
 Select Operation - File menu ..... 4.29  
 Select Preset Type - DM ..... 4.224  
 Select Ramp to Edit - DM ..... 4.223  
 Select Test Point ..... 4.11,6.229  
 Selection field ..... 3.14  
 Self test ..... 6.5,6.229  
 Selftest Execute  
     Baseband Connection Selftest ..... 4.12,6.229  
     LVDS Rate ..... 4.12,6.229  
     Tx Test ..... 4.12,6.230  
 Self-test failed ... (-330) ..... 9.9  
 Semicolon (separator) ..... 5.23  
 SENSOR ..... 1.11  
 Sensor - Power Sensors ..... 4.87  
 Serial bus ..... 4.8  
 Serial number ..... 6.4  
 Serial numbers ..... 4.8  
 Serial poll ..... 5.33  
 Service request (SRQ) ..... 6.5  
 Service Request (SRQ) ..... 5.33  
 Set acc. to Standard - DM ..... 6.122,4.210  
 Set Noise Level via ..... 4.163,6.57  
 Set to default - ARB ..... 4.239,6.81  
 Set to default - ARB MCAR ..... 4.264,6.79  
 Set to default - DM ..... 6.120,4.207  
 Setting not possible ..... 3.14  
 Setting Parameters ..... 3.16  
 Settings conflict ... (-221) ..... 9.9  
 Setup ..... 4.5  
 Shape - LF Frequency Sweep ..... 4.123  
 Shape - LF Sweep ..... 6.168  
 Shape - RF Level Sweep ..... 4.119,6.203  
 Shape - RF Sweep ..... 4.114,6.201  
 Short cuts ..... 3.44  
 Show level permanent -  
     Power Sensors ..... 4.88,6.43  
 Sign ..... 5.21

- Signal Duration - ARB MCAR..... 4.266  
Signal Duration - Trigger - ARB..... 4.250,6.88  
Signal Duration - Trigger - DM..... 6.130  
Signal Duration Unit - Trigger -  
ARB..... 4.250,6.88  
Signal Level (RMS)..... 4.179,6.64  
Signal Level (RMS) - Baseband Signal  
Level Measurement ..... 4.181,6.62  
Signal Period Mode - ARB MCAR..... 4.266,6.80  
Signal Routing - Baseband..... 4.185  
Sine Testsignals - ARB..... 4.255  
Slope - External baseband trigger..... 4.15,6.206  
Slope - Instrument trigger input ..... 4.15,6.207  
Softkey..... 3.12  
Software Compatibility..... 1.26  
Software options..... 4.9,6.4  
Source - AM..... 4.129,6.51  
Source - Baseband Signal  
Level Measurement ..... 4.180,6.62  
Source - FM..... 4.136,6.157  
Source - Level Sweep Trigger..... 4.117,6.234  
Source - LF Sweep Trigger ..... 4.121,6.231  
Source - List Mode Trigger..... 4.102,6.181  
Source - PhiM..... 4.140  
Source - PM..... 6.185  
Source - Power Sensors..... 6.47  
Source - Pulse Modulation ..... 4.134,6.195  
Source - Reference Oscillator ..... 4.78,6.197  
Source - RF Sweep Trigger..... 4.111,6.232  
Source Import/Export- List Mode data..... 6.177  
Source Import/Export-  
User Correction data..... 4.97,6.154  
Source Power Ramp Control - DM.. 6.119,4.226  
Spacing - Level Sweep..... 4.119,6.204  
Spacing - LF Sweep ..... 4.123,6.169  
Spacing - RF Sweep..... 4.114,6.201  
Span (RF sweep)..... 4.114,6.161  
Special characters ..... 6.1  
Spectrum display ..... 4.46  
Square brackets ..... 5.19  
SRE (service request enable register) ..... 5.31  
SRQ (service request) ..... 6.5  
Standard - DM ..... 6.122,4.210  
Standard settings - ARB..... 4.239  
Standard settings - ARB MCAR ..... 4.264  
Standard settings - DM..... 6.120,4.207  
Standby mode..... 1.12  
Start - BERT ..... 6.14  
Start - BLER..... 6.14  
Start - Power Sensors ..... 6.42  
Start delay - ARB MCAR ..... 4.268,6.72  
Start Freq..... 4.113,6.162  
Start Freq - LF Sweep ..... 4.123,6.166  
Start Level..... 4.119,6.192  
Start menu - Windows XP ..... 1.32,1.35,1.36  
Start phase - ARB MCAR..... 4.268,6.73  
Start Select – Data Editor..... 4.220  
Start/Stop Gui Update ..... 4.9,6.224  
Starting gain - ARB MCAR..... 4.267  
Starting power - ARB MCARrier ..... 6.73  
Startup complete..... 6.227  
State - ALC ..... 4.85,6.188  
State - analog Impairments..... 4.146,6.210  
State - ARB..... 4.239,6.82  
State - AWGN ..... 4.161,6.60  
State - Baseband Signal  
Level Measurement..... 4.180,6.63  
State - BERT..... 4.52,6.14  
State - BLER..... 4.63,6.14  
State - digital Impairments ..... 6.146,4.154  
State - DM..... 6.123,4.207  
State - List Mode..... 4.102,6.160  
State - Power Sensors ..... 4.88  
State - Pulse Modulation..... 4.133,6.195  
State - User Correction ..... 4.93,6.155  
State Power Ramp Control - DM .... 6.119,4.226  
State test point..... 4.11,6.24  
Status - LXI ..... 5.12  
status bar ..... 1.3  
Status register overview..... 5.30  
Status reporting system ..... 5.30  
Status reporting system - commands ..... 6.219  
STB (status byte) ..... 5.31  
Step - Level Sweep..... 4.119,6.204  
Step Lin - LF Sweep ..... 4.124,6.169  
Step Lin - RF Sweep..... 4.115,6.201  
Step Log - LF Sweep ..... 4.124,6.169  
Step Log - RF Sweep..... 4.115,6.202  
Step width - Frequency..... 4.74,6.162  
Step width - Level Sweep ..... 4.119,6.204  
Step width - RF Sweep ..... 4.115,6.201  
Stop BERT ..... 6.14  
Stop BLER ..... 6.14  
Stop Freq - LF Sweep..... 4.123,6.166  
Stop Freq - RF Sweep ..... 4.114,6.162  
Stop Level..... 4.119,6.193  
Stopped - DM..... 4.230  
String data not allowed (-158)..... 9.10  
Strings..... 5.22  
Suffix not allowed (-138) ..... 9.10  
Suffix too long (-134)..... 9.10  
Sweep - Center frequency ..... 4.114,6.158  
Sweep - LF start frequency..... 4.123,6.166  
Sweep - LF stop frequency..... 4.123,6.166  
Sweep - RF Sweep ..... 4.111,6.160,6.191,6.200  
Sweep - Start Level..... 4.119,6.192  
Sweep - Stop Level..... 4.119,6.193  
Sweep - Trigger ..... 4.113,4.118,4.122,6.234  
Sweep shape - LF Frequency Sweep..... 4.123  
Sweep shape - LF Sweep..... 6.168  
Sweep shape - RF Level Sweep .... 4.119,6.203  
Sweep shape - RF Sweep ..... 4.114,6.201  
Sweep spacing - Level Sweep..... 4.119,6.204  
Sweep spacing - RF Sweep..... 4.114,6.201  
Symantec Norton Antivirus 2005 ..... 1.52  
SYMBCLK - output..... 4.19

Symbol Clock Multiplier - DM ..... 6.113,4.234  
 Symbol Rate - DM ..... 6.122,4.212  
 Synchronization bandwidth –  
   Reference oscillator ..... 4.79,6.196  
 Synchronizing data  
   signals and clock signals ..... 4.190  
 Syntax error (-102) ..... 9.10  
 System Bandwidth - AWGN ..... 4.161,6.54  
 System error (-310) ..... 9.10  
 System Properties ..... 1.35,1.41

**T**

Tables ..... 3.14  
 Tag - CLOCK ..... 6.101  
 Tag - COMMENT ..... 6.101  
 Target CW Frequency - AWGN ..... 4.163  
 Taste LOCAL ..... 5.9  
 TCP/IP Mode - LXI ..... 5.13  
 Terminator recognition ..... 6.223  
 Test point voltage display ..... 4.11,6.24  
 Test Signal - ARB ..... 4.256,6.90  
 Text parameters ..... 5.22  
 This modulation forces other  
   modulations off (140) ..... 9.15  
 Threshold - BERT ..... 4.59,6.15  
 Threshold - BLER ..... 4.69,6.15  
 Threshold data input (ser/par) ..... 4.14,6.205  
 Threshold trigger/control signal input 4.14,6.207  
 Too many digits (-124) ..... 9.11  
 Too much data (-223) ..... 9.11  
 Trigger - BERT ..... 4.57,6.16  
 Trigger - BLER ..... 4.67,6.16  
 TRIGGER 1 input ..... 1.10  
 Trigger Delay External - ARB ..... 4.251,6.83  
 Trigger Delay External - DM ..... 6.124,4.231  
 Trigger Delay Other Baseband -  
   ARB ..... 4.251,6.84  
 Trigger Delay Other Baseband -  
   DM ..... 6.125,4.231  
 Trigger Inhibit External - ARB ..... 4.252,6.83  
 Trigger Inhibit External - DM ..... 6.125,4.231  
 Trigger Inhibit Other Baseband -  
   ARB ..... 4.252,6.84  
 Trigger Inhibit Other Baseband -  
   DM ..... 6.125,4.231  
 Trigger input ..... 1.18,1.19  
 Trigger Mode - ARB ..... 4.249,6.81  
 Trigger Mode - DM ..... 6.121,4.229  
 Trigger output ..... 1.14  
 Trigger parameters - ARB ..... 4.248  
 Trigger parameters - DM ..... 4.228  
 Trigger Signal Duration - DM ..... 4.229  
 Trigger signals ..... 4.194  
 Trigger Source - ARB ..... 4.251,6.89  
 Trigger Source - DM ..... 6.130,4.230  
 Trigger Source - Graphics ..... 4.37  
 Trigger Source - Level Sweep ..... 4.117,6.234

Trigger Source - LF Sweep ..... 4.121,6.231  
 Trigger Source - List Mode ..... 4.102,6.181  
 Trigger Source - RF Sweep ..... 4.111,6.232  
 Triggering sweep manually... 4.118,6.199,6.202  
 Tuning input ..... 4.19  
 Tx Test Selftest ..... 4.12,6.230  
 Type - Power Sensors ..... 4.87,6.48

**U**

UCorr ..... 9.3  
 Ultr@VNC ..... 1.45  
 Undefined header (-113) ..... 9.11  
 Uninterrupted level setting ..... 4.82,6.39  
 Unit - BERT ..... 4.53,6.15  
 Unit - BLER ..... 4.64,6.15  
 Unit - Power Sensors ..... 4.88,6.43  
 Units ..... 3.14  
 Universal command ..... 8.5  
 Unix controller ..... 1.45  
 Unknown list type specified (242) ..... 9.15  
 Update - Setup System ..... 4.10  
 Upper case ..... 6.1  
 USB Device - Setup ..... 4.23  
 USB interface ..... 1.16  
 Use Level Adjustment Data ..... 4.7,6.19  
 Use SParameters - Power Sensors... 4.91,6.43  
 User Clock - ARB ..... 4.259,6.95  
 User Correction ..... 4.92,6.147  
 User Correction Data ..... 4.93,6.148  
 User Filter - DM ..... 6.139  
 User Filter Catalog - DM ..... 6.138,4.216  
 User Filter Delete - DM ..... 6.138,4.216  
 User Filter Free Memory - DM ..... 6.139  
 User Filter List Length - DM ..... 6.139  
 USER input/output ..... 1.19  
 User Mapping Catalog - DM ..... 4.212  
 User Mapping Delete - DM ..... 4.212  
 User mapping Free Memory - DM ..... 6.140  
 User mapping Lists Catalog - DM ..... 6.140  
 User Mapping Lists Delete - DM ..... 6.140  
 User Marker -  
   AUX I/O Configuration... 4.115,4.120,4.124  
 User Modulation  
   Mapping List Length - DM ..... 6.141  
 user name ..... 1.26

**V**

Value - User Correction ..... 4.93  
 Variable FSK Deviation - DM ..... 6.117,4.214  
 Variation Active ..... 4.74  
 Variation Step ..... 4.74,4.83,6.162,6.163,6.192  
 Vector diagram ..... 4.42  
 Vector modulation ..... 4.143,6.208  
 Virus-protection software .... 1.26,1.29,1.30,1.52  
 Visa Resource String - Ethernet ..... 4.20,6.224  
 Visual check of signal characteristics ..... 4.35

VNC connection.....	1.45
Voltage - LF output.....	6.170
Voltage - Test point .....	4.11
Voltage threshold.....	4.14,6.207
VXI-11 - LXI .....	5.14

## W

Wait Time - Setup.....	4.16,6.25
Warnings.....	9.4,3.8
Waveform File.....	4.240,6.92,6.93
Waveform Protected (261) .....	9.15
White space .....	5.23
Wideband setting - I/Q.....	4.145,6.210
winbar .....	1.3
Winbar .....	3.12
Window XP access.....	1.26
Windows button .....	3.15
Windows Firewall.....	1.36
Windows Firewall - Exceptions tab.....	1.49
Windows Firewall - General tab.....	1.48
Windows XP Firewall.....	1.36

## Z

Zero - Power Sensors.....	4.89,6.48
---------------------------	-----------